

TTL SJ-1520 Series

Description

The **SJ-1520 Series** of quartz crystal oscillators provide enable/disable 3-state TTL compatible signals for bus connected systems. Supplying Pin 1 of the SJ-1520 units with a logic "1" enables its output on Pin 3. In the disabled mode, Pin 3 presents a high impedance to the load.

Features

- Wide frequency range– 0.5MHz to 85.0MHz
- User specified tolerance available
- Will withstand vapor phase temperatures of 253°C for 4 minutes maximum
- Space-saving alternative to discrete component oscillators
- High shock resistance, to 3000g
- Metal lid electrically connected to ground to reduce EMI
- Low Jitter
- High Q Crystal actively tuned oscillator circuit
- Power supply decoupling internal
- No internal PLL avoids cascading PLL problems
- Low power consumption
- Gold plated leads

Electrical Connection

Pin	Connection
1	Enable Input
2	Grd & Case
3	Output
4	V _{CC}

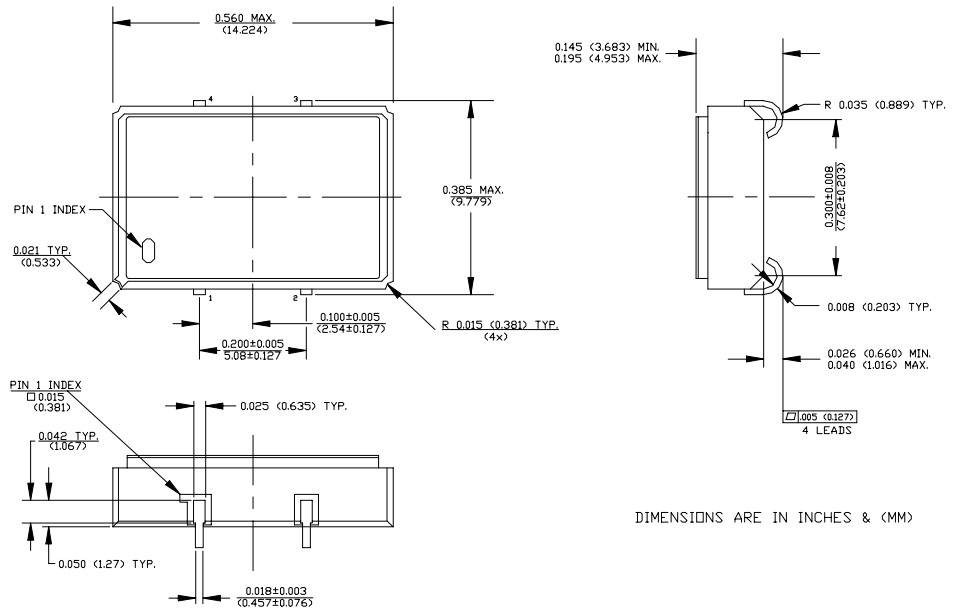

SJ-1520 Continued
TTL

Rev. B

Operating Conditions and Output Characteristics

Electrical Characteristics

Parameter	Symbol	Conditions	Min	Typical	Max
Frequency	----	----	0.5MHz	----	85.0MHz
Duty Cycle	----	@ V _{CC} /2	40/60%	----	60/40%
Logic 0	V _{OL}	@ 16mA	----	----	0.4V
Logic 1	V _{OH}	@ 0.4mA	2.4V	----	----
Rise & Fall Time	tr,tf	@ 0.4 to 2.4V	----	----	----
		<40MHz	----	----	8 ns
		40MHz or greater	----	----	5 ns
T _{pz}	----	----	----	----	25 ns
Jitter, RMS ⁽²⁾	----	<40MHz OT & >40MHz	----	----	5 psec
		<40MHz Fund	----	----	8 psec
Frequency Stability ⁽¹⁾	dF/F	Overall conditions including: voltage, calibration, temp., 10 yr aging, shock, vibration	-100ppm	----	+100ppm

General Characteristics

Parameter	Symbol	Conditions	Min	Typical	Max
Supply Voltage	V _{CC}	----	4.75V	5.0V	5.25V
Supply Current	I _{CC}	No Load	0.0 mA	----	50 mA
Output current	I _O	----	0.0 mA	----	±16.0 mA
Operating temperature	T _A	----	0°C	----	70°C
Storage temperature	T _S	----	-55°C	----	125°C
Power Dissipation	P _D	----	----	----	263 mW
Lead temperature	T _L	Soldering, 10 sec.	----	----	300°C
Load	----	----	----	----	10TTL gate
Start-up time	t _s	<20MHz	----	----	2 ms
		20MHz or greater	----	----	10 ms

Environmental and Mechanical Characteristics

Mechanical Shock Per MIL-STD-202, Method 213, Condition E
 Thermal Shock Per MIL-STD-833, Method 1011, Condition A
 Vibration 0.060" double amplitude 10 Hz to 55 Hz, 35g's 55Hz to 2000 Hz
 Soldering Condition 300°C for 10 seconds
 Hermetic Seal Leak rate less than 1 x 10⁻⁸ atm.cc/sec of helium

Footnotes:

- 1) Standard frequency stability (±20,±25,±50ppm & others available)
- 2) Jitter performance is frequency dependent. Please contact factory for full characterization.

Creating a Part Number	
SJ - X152X - FREQ	
Package Code	Tolerance/Performance
SJ 4 J Lead SMD	0 ±100ppm 0-70°C
	1 ±50ppm 0-70°C
	7 ±25ppm 0-70°C
Input Voltage	9 Customer Specific
Code Specification	A ±20ppm 0-70°C
A 3.3V	B ±50ppm -40 to +85°C
5V	C ±100ppm -40 to +85°C

Test Load:

