

## Differential Positive ECL (DPECL) Fast Edge PJ-A2940 Series

Preliminary

### Description

The **PJ-A2940 Series** of quartz crystal oscillators provide DPECL Fast Edge compatible signals. Systems designers may now specify space-saving, cost-effective packaged PECL oscillators to meet their timing requirements.

### Features

- Wide frequency range—80.0MHz to 200.0MHz
- User specified tolerance available
- Will withstand vapor phase temperatures of 253°C for 4 minutes maximum
- Space-saving alternative to discrete component oscillators
- High shock resistance, to 3000g
- 3.3 volt operation
- Fast rise and fall times <600 ps
- Metal lid electrically connected to ground to reduce EMI
- High Reliability - NEL HALT/HASS qualified for crystal oscillator start-up conditions
- Low Jitter - Wavecrest jitter characterization available
- Overtone technology
- High Q Crystal actively tuned oscillator circuit
- Power supply decoupling internal
- No internal PLL avoids cascading PLL problems
- High frequencies due to proprietary design
- Gold plated leads - Solder dipped leads available upon request

### Electrical Connection

Pin	Connection
1	Enable/Disable
2	NC
3	V <sub>EE</sub>
4	Output
5	Output Complement
6	V <sub>CC</sub>

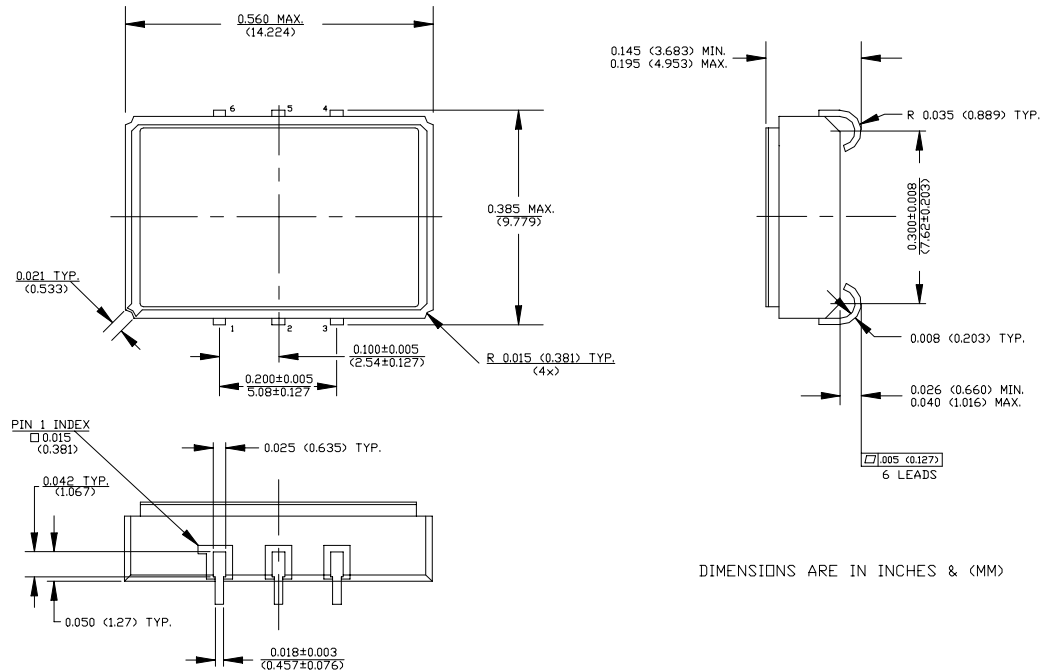

DIMENSIONS ARE IN INCHES & (MM)

**PJ-A2940 Series** Continued  
Differential Positive ECL (DPECL) Fast Edge

Rev. E

## Operating Conditions and Output Characteristics

### Electrical Characteristics

Parameter	Symbol	Conditions	Min	Typical	Max
Frequency	----	----	80.0MHz	----	200.0MHz
Duty Cycle	----	@ V <sub>CC</sub> -1.29V	45/55%	----	55/45%
Logic 0 <sup>(2)</sup>	V <sub>OL</sub>	----	1.35V	----	1.70V
Logic 1 <sup>(2)</sup>	V <sub>OH</sub>	----	2.28V	----	2.56V
Rise & Fall Time	tr,tf	20-80%V <sub>O</sub> with 50 ohm load to V <sub>CC</sub> -2V	----	----	600 psec
Tpd <sup>(4)</sup>	----	----	-200 psec	----	+200 psec
Jitter, RMS <sup>(3)</sup>	----	----	----	----	3 psec
Frequency Stability <sup>(1)</sup>	dF/F	Overall conditions including: voltage, calibration, temp., 10 yr aging, shock, vibration	-100ppm	----	+100ppm

### General Characteristics

Parameter	Symbol	Conditions	Min	Typical	Max
Supply Voltage	V <sub>CC</sub>	----	3.15V	3.3V	3.45V
Supply Current	I <sub>CC</sub>	50 ohm termination To 2.00V below V <sub>CC</sub>	0.0 mA	----	110 mA
Output current	I <sub>O</sub>	Low level Output Current	0.0 mA	----	±50.0 mA
Operating temperature	T <sub>A</sub>	----	0°C	----	70°C
Storage temperature	T <sub>S</sub>	----	-55°C	----	125°C
Power Dissipation	P <sub>D</sub>	----	----	----	276 mW
Lead temperature	T <sub>L</sub>	Soldering, 10 sec.	----	----	300°C
Load	50 Ohm to V <sub>CC</sub> -2V or Thevenin Equivalent, Bias Required	----	----	----	----
Start-up time	t <sub>s</sub>	----	----	2 ms	10 ms

### Environmental and Mechanical Characteristics

Mechanical Shock	Per MIL-STD-202, Method 213, Condition E
Thermal Shock	Per MIL-STD-883, Method 1011, Condition A
Vibration	0.060" double amplitude 10 Hz to 55 Hz, 35g's 55Hz to 2000 Hz
Soldering Condition	300°C for 10 seconds
Hermetic Seal	Leak rate less than 1 x 10 <sup>-8</sup> atm.cc/sec

#### Footnotes:

- 1) Standard frequency stability (±20,±25,±50ppm & others available)
- 2) V<sub>OL</sub>, V<sub>OH</sub>, referenced to ground (V<sub>EE</sub>) with V<sub>CC</sub> = 3.3V
- 3) Jitter performance is frequency dependent. Please contact factory for full Wavecrest characterization.
- 4) Tpd is phase shift between the falling edge of pin 3 at 2.0V and the rising edge of pin 1 at 2.01V.

Creating a Part Number	
<b>PJ - A294X - FREQ</b>	
<b>Package Code</b>	<b>Tolerance/Performance</b>
PJ 6 J Lead SMD	0 ±100ppm 0-70°C
	1 ±50ppm 0-70°C
	7 ±25ppm 0-70°C
	9 Customer Specific
<b>Input Voltage</b>	A ±20ppm 0-70°C
Code Specification	B ±50ppm -40 to +85°C
A 3.3V	C ±100ppm -40 to +85°C
5V	

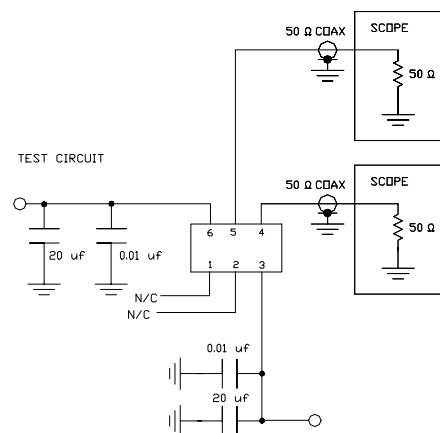

TEST CIRCUIT USES A SPLIT SUPPLY OF +2V AND -1.3V FOR EASE OF TESTING.