

Differential Positive ECL (DPECL) SJ-A2870 Series

Description

The **SJ-A2870 Series** of quartz crystal oscillators provide MECL 10K and 10KH series compatible signals in a ceramic SMD package. Systems designers may now specify space-saving, cost-effective packaged PECL oscillators to meet their timing requirements.

Features

- Wide frequency range—18.0MHz to 250.0MHz
- User specified tolerance available
- Will withstand vapor phase temperatures of 253°C for 4 minutes maximum
- Space-saving alternative to discrete component oscillators
- High shock resistance, to 3000g
- 3.3 volt operation
- Metal lid electrically connected to ground to reduce EMI
- MECL 10K and 10KH series compatible output on Pin 3, complement on Pin 1
- Low Jitter - Wavecrest jitter characterization available
- High Reliability - NEL HALT/HASS qualified for crystal oscillator start-up conditions
- High Q Crystal actively tuned oscillator circuit
- Power supply decoupling internal
- No internal PLL avoids cascading PLL problems
- High frequencies due to proprietary design
- Gold plated leads - Solder dipped leads available upon request

Electrical Connection

Pin	Connection
1	Output Complement
2	V _{EE} /Ground
3	Output
4	V _{CC}

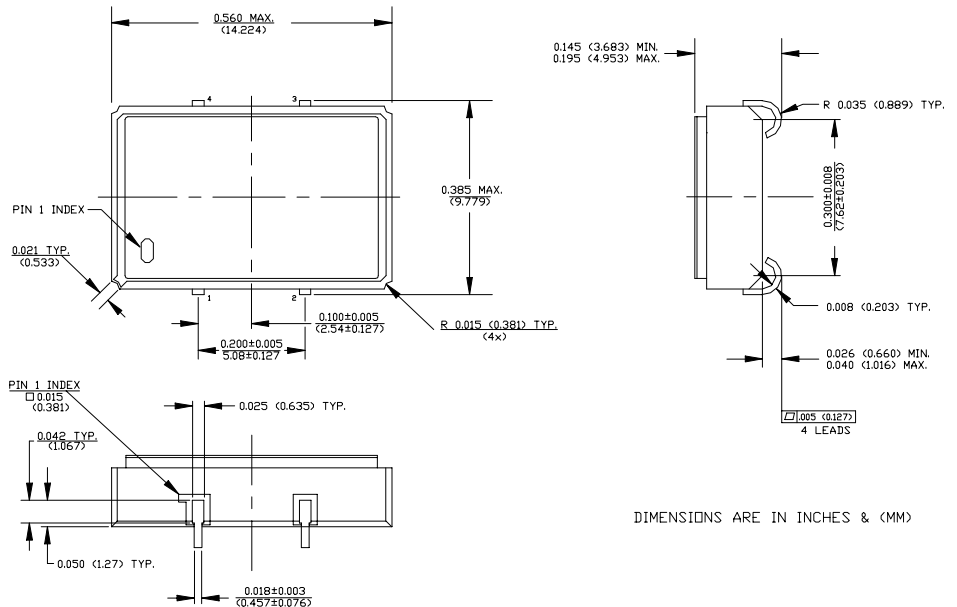

SJ-A2870 Series Continued Differential Positive ECL (DPECL)

Rev. L

Operating Conditions and Output Characteristics

Electrical Characteristics

Parameter	Symbol	Conditions	Min	Typical	Max
Frequency	----	----	18.0MHz	----	250.0MHz
Duty Cycle	----	@ $V_{CC}-1.29V$	45/55%	----	55/45%
Logic 0 ⁽²⁾	V_{OL}	----	1.35V	----	1.70V
Logic 1 ⁽²⁾	V_{OH}	----	2.28V	----	2.56V
Rise & Fall Time	tr,tf	20-80% V_O with 50 ohm load to $V_{CC}-2V$	----	1.0 ns	1.5 ns
Tpd ⁽⁴⁾	----	----	-0.5 ns	----	+0.5 ns
Jitter, RMS ⁽³⁾	----	----	----	----	3 psec
Frequency Stability ⁽¹⁾	dF/F	Overall conditions including: voltage, calibration, temp., 10 yr aging, shock, vibration	-100ppm	----	+100ppm

General Characteristics

Parameter	Symbol	Conditions	Min	Typical	Max
Supply Voltage	V_{CC}	----	3.15V	3.3V	3.45V
Supply Current	I_{CC}	50 ohm termination To 2.00V below V_{CC}	0.0 mA	----	80 mA
Output current	I_O	Low level Output Current	0.0 mA	----	±50.0 mA
Operating temperature	T_A	----	----	----	70°C
Storage temperature	T_S	----	-55°C	----	125°C
Power Dissipation	P_D	----	----	----	276 mW
Lead temperature	T_L	Soldering, 10 sec.	----	----	300°C
Load		50 Ohm to $V_{CC}-2V$ or Thevenin Equivalent, Bias Required			
Start-up time	t_s	----	----	2 ms	10 ms

Environmental and Mechanical Characteristics

Mechanical Shock	Per MIL-STD-202, Method 213, Condition E
Thermal Shock	Per MIL-STD-833, Method 1011, Condition A
Vibration	0.060" double amplitude 10 Hz to 55 Hz, 35g's 55Hz to 2000 Hz
Soldering Condition	300°C for 10 seconds
Hermetic Seal	Leak rate less than 1×10^{-8} atm.cc/sec of helium
ESD Sensitivity	Human Body Model per ON Semiconductor 10kH series ECL: 500V min.

Footnotes:

- 1) Standard frequency stability ($\pm 20, \pm 25, \pm 50$ ppm & others available)
- 2) V_{OL}, V_{OH} , referenced to ground (V_{EE}) with $V_{CC} = 3.3V$
- 3) Jitter performance is frequency dependent. Please contact factory for full Wavecrest characterization.
- 4) Tpd is phase shift between the falling edge of pin 3 at $V_{CC}-1.29V$ and rising edge of pin 1 at $V_{CC}-1.29V$.

Creating a Part Number	
SJ - A287X - FREQ	
Package Code	Tolerance/Performance
SJ 4 J Lead SMD	0 ±100ppm 0-70°C
	1 ±50ppm 0-70°C
	7 ±25ppm 0-70°C
	9 Customer Specific
Input Voltage	A ±20ppm 0-70°C
Code Specification	B ±50ppm -40 to +85°C
A 3.3V	C ±100ppm -40 to +85°C
5V	

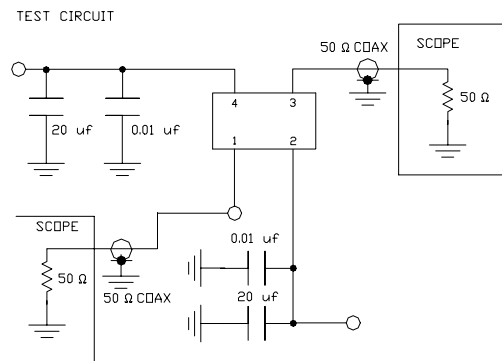

TEST CIRCUIT USES A SPLIT SUPPLY OF +2V AND -1.3V FOR EASE OF TESTING.