

**GENERAL DESCRIPTION**

This Series of fixed-voltage monolithic integrated circuit voltage regulators is designed for a wide range of applications. These applications include on-card regulation for elimination of noise and distribution problems associated with single-point regulation. In addition, they can be used with power-pass elements to make high-current voltage regulators. One of these regulators can deliver up to 100 mA of output current. The internal limiting and thermal shutdown features of these regulators make them essentially immune to overload. When used as a replacement for a zener diode-resistor combination, an effective improvement in output impedance can be obtained together with lower-bias current.

**FEATURES**

- 3-terminal regulators
- Output current up to 100 mA
- No external component
- Internal thermal overload protection
- Internal short-circuit current limiting
- Direct replacements for LM78L00,  $\mu$ A78L00 and AN78L00 series

**APPLICATIONS**

- Linear regulator
- Instrumentation
- Switching power supplies
- PCs, Industrial equipment

**PIN CONFIGURATIONS**

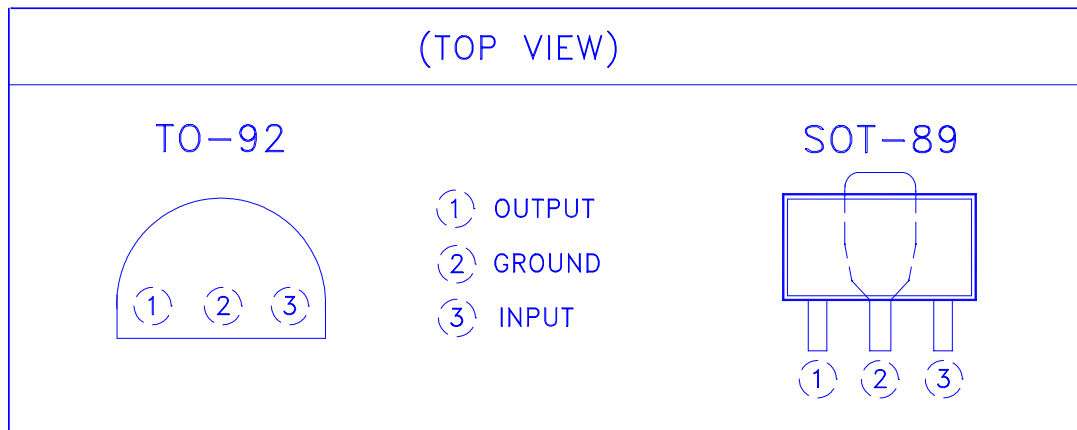

**DEVICE SELECTION GUIDE**

|                |         |         |         |         |
|----------------|---------|---------|---------|---------|
| <b>Device</b>  | L78L05N | L78L05C | L78L12N | L78L12C |
| <b>Package</b> | TO-92   | SOT-89  | TO-92   | SOT-89  |
| <b>Marking</b> | 78L05   | 78L05   | 78L12   | 78L12   |

**ABSOLUTE MAXIMUM RATINGS**

| PARAMETER  | VALUE          |
|--|----------------|
| Input Voltage - $V_I$                            | 30V            |
| Continuous total power dissipation               | (See Note 1)   |
| Storage Temperature Range - $T_{STG}$            | -65 to +150 °C |
| Junction Temperature - $T_J$                     | 125 °C         |
| Lead Temperature (Soldering, 10 Seconds) - $T_L$ | 260 °C         |

Note1: To avoid exceeding the design maximum virtual junction temperature, three ratings should not be exceeded. Due to variations in individual device electrical characteristics and thermal resistance, the built-in thermal overload protection may be activated at power levels slightly above or below the rated dissipation.

**DISSIPATION RATING TABLE 1 – FREE-AIR TEMPERATURE**

| PACKAGE | $T_A \leq 25^\circ\text{C}$<br>POWER RATING | DERATING<br>FACTOR | DERATING<br>ABOVE $T_A$ | $T_A = 70^\circ\text{C}$<br>POWER RATING |
|---------|---|--------------------|-------------------------|--|
| TO-92   | 650 mW                                      | 6.2 mW/°C          | 25 °C                   | 350 mW                                   |
| SOT-89  | 500 mW                                      | 4.0 mW/°C          | 25 °C                   | 300 mW                                   |

† The TO-92 package dissipation rating is based on thermal resistance  $\theta_{JA}$  measured in still air with the device mounted in an Augat socket. The bottom of the package is 10mm (0.375 in) above the stock.

**DISSIPATION RATING TABLE 2 – CASE TEMPERATURE**

| PACKAGE | $T_A \leq 25^\circ\text{C}$<br>POWER RATING | DERATING<br>FACTOR | DERATING<br>ABOVE $T_C$ | $T_C = 125^\circ\text{C}$<br>POWER RATING |
|---------|---|--------------------|-------------------------|---|
| TO-92   | 1600 mW                                     | 28.6 mW/°C         | 94 °C                   | 713 mW                                    |
| SOT-89  | 3125 mW                                     | 25.0 mW/°C         |                         |   |

**RECOMMENDED OPERATING CONDITIONS**

| PARAMETER                                      | VALUE                     |
|--|---------------------------|
| Input Voltage - $V_I$<br>L78L05<br>L78L12      | 7V to 20V<br>14.5V to 27V |
| Output Current - $I_{OUT}$                     | 100 mA (Max)              |
| Operating Virtual Junction Temperature - $T_J$ | 0 to 125 °C               |

**ELECTRICAL SPECIFICATIONS (L78L05)**

( $V_I = 10V$ ,  $I_O = 40\text{ mA}$ ,  $C_I = 0.33\text{ }\mu\text{F}$ ,  $C_O = 0.1\text{ }\mu\text{F}$ ,  $0\text{ }^\circ\text{C} < T_J < +125\text{ }^\circ\text{C}$  unless otherwise noted.)

| PARAMETER                 | TEST CONDITIONS   | MIN          | TYP       | MAX          | UNITS         |
|---------------------------|---|--------------|-----------|--------------|---------------|
| Output Voltage            | $T_J = +25\text{ }^\circ\text{C}$   | 4.8          | 5.0       | 5.2          | V             |
| Line Regulation           | $T_J = +25\text{ }^\circ\text{C}$ , $I_O = 40\text{ mA}$<br>$7.0V \leq V_I \leq 20V$<br>$8.0V \leq V_I \leq 20V$                  |              | 55<br>45  | 150<br>100   | mV            |
| Load Regulation           | $T_J = +25\text{ }^\circ\text{C}$<br>$1.0\text{ mA} \leq I_O \leq 100\text{ mA}$<br>$1.0\text{ mA} \leq I_O \leq 40\text{ mA}$    |              | 11<br>5.0 | 60<br>30     | mV            |
| Output Voltage            | $7.0V \leq V_I \leq 20V$ , $1.0\text{ mA} \leq I_O \leq 40\text{ mA}$<br>$V_I = 10V$ , $1.0\text{ mA} \leq I_O \leq 70\text{ mA}$ | 4.75<br>4.75 |           | 5.25<br>5.25 | V             |
| Input Bias Current        | $T_J = +25\text{ }^\circ\text{C}$<br>$T_J = +125\text{ }^\circ\text{C}$   |              | 3.8       | 6.0<br>5.5   | mA            |
| Input Bias Current Change | $8.0V \leq V_I \leq 20V$<br>$1.0\text{ mA} \leq I_O \leq 40\text{ mA}$  |              |           | 1.5<br>0.1   | mA            |
| Output Noise Voltage      | $T_A = +25\text{ }^\circ\text{C}$ , $10\text{ Hz} \leq f \leq 100\text{ KHz}$   |              | 40        |              | $\mu\text{V}$ |
| Ripple Rejection          | $T_J = +25\text{ }^\circ\text{C}$ , $I_O = 40\text{ mA}$ , $f = 120\text{ Hz}$<br>$8.0V \leq V_I \leq 18V$                        | 41           | 49        |              | nA            |
| Dropout Voltage           | $T_J = +25\text{ }^\circ\text{C}$   |              | 1.7       |              | V             |

**ELECTRICAL SPECIFICATIONS (L78L12)**

( $V_I = 19V$ ,  $I_O = 40\text{ mA}$ ,  $C_I = 0.33\text{ }\mu\text{F}$ ,  $C_O = 0.1\text{ }\mu\text{F}$ ,  $0\text{ }^\circ\text{C} < T_J < +125\text{ }^\circ\text{C}$  unless otherwise noted.)

| PARAMETER                 | TEST CONDITIONS  | MIN          | TYP        | MAX          | UNITS         |
|---------------------------|--|--------------|------------|--------------|---------------|
| Output Voltage            | $T_J = +25\text{ }^\circ\text{C}$  | 11.5         | 12.0       | 12.5         | V             |
| Line Regulation           | $T_J = +25\text{ }^\circ\text{C}$ , $I_O = 40\text{ mA}$<br>$14.5V \leq V_I \leq 27V$<br>$16V \leq V_I \leq 27V$                   |              | 120<br>100 | 250<br>200   | mV            |
| Load Regulation           | $T_J = +25\text{ }^\circ\text{C}$<br>$1.0\text{ mA} \leq I_O \leq 100\text{ mA}$<br>$1.0\text{ mA} \leq I_O \leq 40\text{ mA}$     |              | 20<br>10   | 100<br>50    | mV            |
| Output Voltage            | $14.5V \leq V_I \leq 27V$ , $1.0\text{ mA} \leq I_O \leq 40\text{ mA}$<br>$V_I = 19V$ , $1.0\text{ mA} \leq I_O \leq 70\text{ mA}$ | 11.4<br>11.4 |            | 12.6<br>12.6 | V             |
| Input Bias Current        | $T_J = +25\text{ }^\circ\text{C}$<br>$T_J = +125\text{ }^\circ\text{C}$  |              | 4.2        | 6.5<br>6.0   | mA            |
| Input Bias Current Change | $16V \leq V_I \leq 27V$<br>$1.0\text{ mA} \leq I_O \leq 40\text{ mA}$  |              |            | 1.5<br>0.1   | mA            |
| Output Noise Voltage      | $T_A = +25\text{ }^\circ\text{C}$ , $10\text{ Hz} \leq f \leq 100\text{ KHz}$  |              | 80         |              | $\mu\text{V}$ |
| Ripple Rejection          | $T_J = +25\text{ }^\circ\text{C}$ , $I_O = 40\text{ mA}$ , $f = 120\text{ Hz}$<br>$15V \leq V_I \leq 25V$                          | 37           | 42         |              | nA            |
| Dropout Voltage           | $T_J = +25\text{ }^\circ\text{C}$  |              | 1.7        |              | V             |

**TO-92 MECHANICAL DATA**

| Dimension | mm    |      |       | Dimension | mm    |       |       |
|-----------|-------|------|-------|-----------|-------|-------|-------|
|           | Min.  | Typ. | Max.  |           | Min.  | Typ.  | Max.  |
| A         | 4.445 |      | 5.207 | H         | 2.413 | 2.540 | 2.667 |
| B         | 4.318 |      | 5.334 | I         | 0.356 |       | 0.533 |
| C         | 12.7  |      | 15.5  | J         |       |       |       |
| D         | 0.356 |      | 0.533 | K         |       |       |       |
| E         | 1.143 | 1.27 | 1.397 | L         |       |       |       |
| F         | 3.175 |      | 4.191 | M         |       |       |       |
| G         | 0.762 |      | 1.270 | N         |       |       |       |

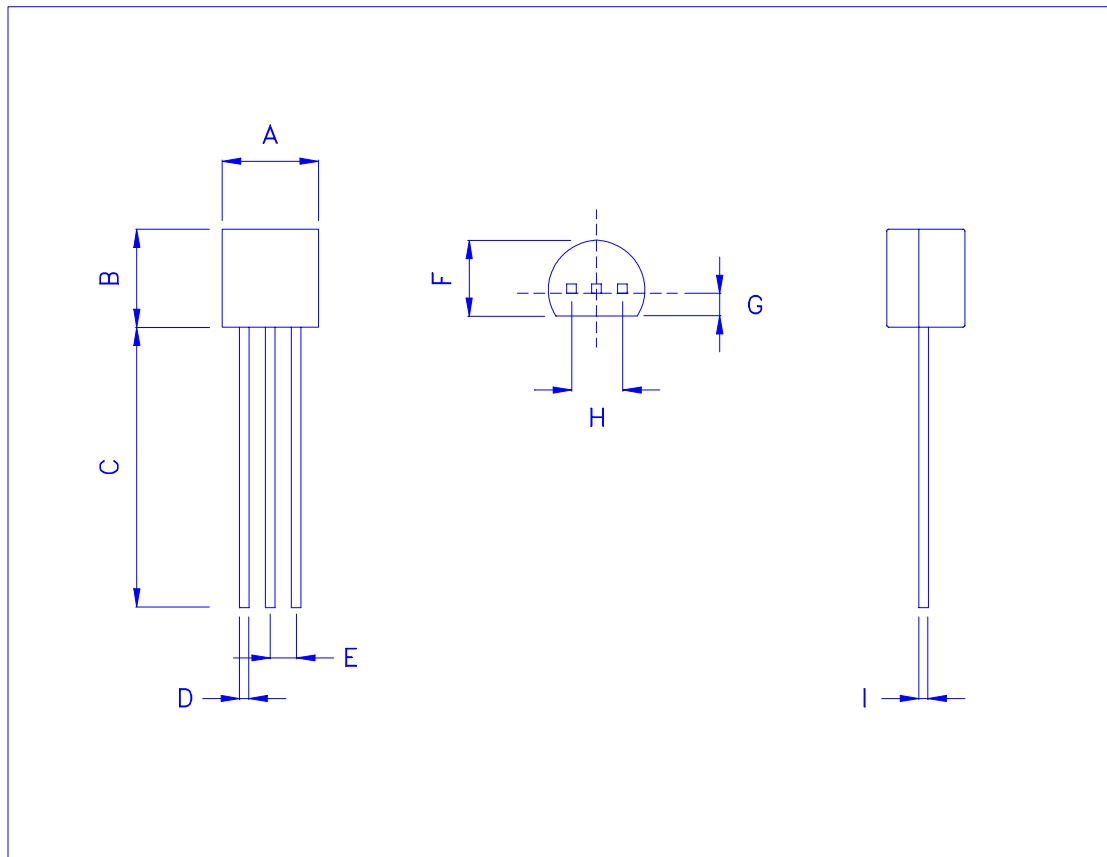

**SOT-89 MECHANICAL DATA**

| Dimension | mm   |      |      | Dimension | mm   |      |      |
|-----------|------|------|------|-----------|------|------|------|
|           | Min. | Typ. | Max. |           | Min. | Typ. | Max. |
| A         | 4.3  | 4.5  | 4.7  | H         | 1.4  | 1.5  | 1.6  |
| B         | 1.6  | 1.7  | 1.8  | I         | 2.8  | 3.0  | 3.2  |
| C         | 0.4  | 0.5  | 0.6  | J         | 1.3  | 1.5  | 1.7  |
| D         | 2.4  | 2.5  | 2.6  | K         | 3.8  | 4.2  | 4.6  |
| E         | 0.8  | 1.2  | 1.4  | L         | 0.3  | 0.4  | 0.5  |
| F         | 0.4  | 0.45 | 0.5  | M         |      |      |      |
| G         | 0.4  | 0.5  | 0.6  | N         |      |      |      |

