

800MHz BAND MIXER GaAs MMIC

■GENERAL DESCRIPTION

NJG1557KB2 is a GaAs MMIC MIXER IC with built-in local amplifier for 800MHz cellular phone handsets.

This mixer features very high input IP3, high conversion gain and low noise figure, and suitable for the application which needs high input IP3 such as CDMA.

An ultra small & ultra thin FLP6-B2 package is adopted.

■PACKAGE OUTLINE



NJG1557KB2

■FEATURES

- | | | |
|-----------------------------------|--------------------------------------|---|
| ●Low voltage operation | +2.8V typ. | |
| ●Low current consumption | 8.7mA typ. | |
| ●High input IP3 | +8dBm typ. | @ $f_{RF}=850.0+850.1\text{MHz}$, $P_{RF}=-25\text{dBm}$
$f_{LO}=740\text{MHz}$, $P_{LO}=-10\text{dBm}$ |
| ●High conversion gain | 9.5dB typ. | @ $f_{RF}=850\text{MHz}$, $P_{RF}=-25\text{dBm}$
$f_{LO}=740\text{MHz}$, $P_{LO}=-10\text{dBm}$, $f_{IF}=110\text{MHz}$ |
| ●Low noise figure | 5.5dB typ. | @ $f_{RF}=850\text{MHz}$
$f_{LO}=740\text{MHz}$, $P_{LO}=-10\text{dBm}$, $f_{IF}=110\text{MHz}$ |
| ●Ultra small & ultra thin package | FLP6-B2 (Mount Size: 2.1x2.0x0.75mm) | |

■PIN CONFIGURATION

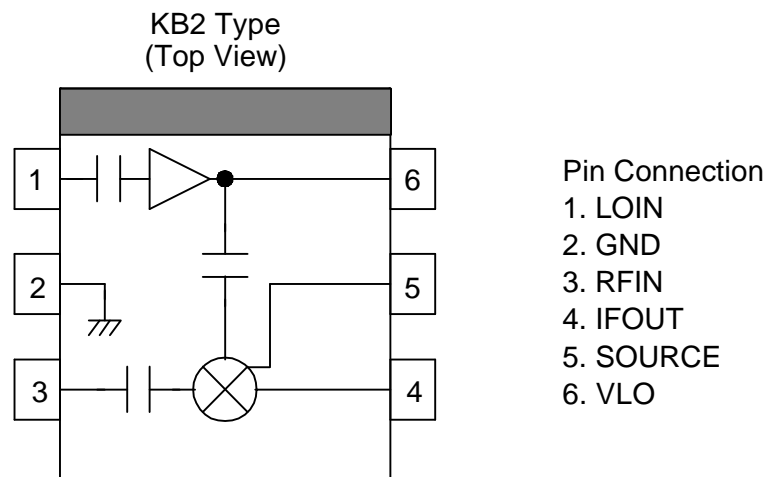

NOTE: The portion above shows orientation mark printed on the package surface.

NOTE: Please note that any information on this catalog will be subject to change.

NJG1557KB2

■ABSOLUTE MAXIMUM RATINGS

($T_a=+25^{\circ}\text{C}$, $Z_s=Z_i=50\Omega$)

PARAMETER	SYMBOL	CONDITIONS	RATINGS	UNITS
Mixer Supply Voltage	V_{MIX}		6.0	V
Local Amp. Supply Voltage	V_{LO}		6.0	V
Mixer RF Input Power	P_{RFIN}	$V_{\text{MIX}}=V_{\text{LO}}=2.8\text{V}$	+10	dBm
Mixer LO Input Power	P_{LOIN}	$V_{\text{MIX}}=V_{\text{LO}}=2.8\text{V}$	+10	dBm
Power Dissipation	P_{D}		450	mW
Operating Temperature	T_{opr}		-40~+85	$^{\circ}\text{C}$
Storage Temperature	T_{stg}		-55~+125	$^{\circ}\text{C}$

■RECOMMENDED OPERATING RANGE

PARAMETER	SYMBOL	CONDITIONS	MIN	TYP	MAX	UNITS
Supply Voltage Mixer	V_{MIX}		2.7	2.8	5.5	V
Supply Voltage Local Amp.	V_{LO}		2.7	2.8	5.5	V

■ELECTRICAL CHARACTERISTICS [DC CHARACTERISTICS]

PARAMETER	SYMBOL	CONDITIONS	MIN	TYP	MAX	UNITS
Total Operating Current	I_{TOTAL}	$I_{\text{MIX}}+I_{\text{LO}}$	-	8.7	10.6	mA
Mixer Current	I_{MIX}	$P_{\text{RF}}=\text{OFF}$, $P_{\text{LO}}=\text{OFF}$	-	7.5	9.3	mA
Local Amp. Current	I_{LO}	$P_{\text{RF}}=\text{OFF}$, $P_{\text{LO}}=\text{OFF}$	-	1.2	1.6	mA

■ELECTRICAL CHARACTERISTICS [AC CHARACTERISTICS]

($V_{\text{MIX}}=V_{\text{LO}}=2.8\text{V}$, $f_{\text{RF}}=850\text{MHz}$, $f_{\text{LO}}=740\text{MHz}$, $f_{\text{IF}}=110\text{MHz}$, $P_{\text{RF}}=-25\text{dBm}$, $P_{\text{LO}}=-10\text{dBm}$, $T_a=+25^{\circ}\text{C}$, $Z_s=Z_i=50\Omega$, Measuring Test Circuit)

PARAMETER	SYMBOL	CONDITIONS	MIN	TYP	MAX	UNITS
Operating RF Frequency	f_{RF}		830	850	900	MHz
Conversion Gain	Gc		8.5	9.5	-	dB
Input 3rd Order Intercept Point	IIP3	$f_{\text{RF}}=850.0+850.1\text{MHz}$	+6.0	+8.0	-	dBm
Noise Figure	NF	SSB	-	5.5	6.5	dB
LO to RF Isolation	ISL	$P_{\text{RF}}=\text{OFF}$	2.0	7.0	-	dB

■ TERMINAL EXPLANATION

PIN No.	SYMBOL	DESCRIPTIONS
1	LOIN	Local power input terminal of local amplifier. External matching circuit is required.
2	GND	Ground terminal (0V). Please place grounding VIAs as close as possible.
3	RFIN	RF signal input terminal of mixer. External matching circuit is required.
4	IFOUT	IF signal output terminal of mixer. External matching circuit is required. Please connect mixer power supply through inductor (L7,L8) as shown in test circuit. Please place bypass capacitor (C5) close to C4
5	SOURCE	Source terminal of mixer FET. Please connect source inductor (L6), bias resistor (R2) and bypass capacitor (C3) as shown in test circuit. These parts should be placed close to this terminal.
6	VLO	Local amplifier power supply terminal. Please place R1 and L5 close to this terminal as shown in test circuit, and place bypass capacitors (C1,C2) close to L5.

NJG1557KB2

■ TYPICAL CHARACTERISTICS ($f_{RF}=830\sim 870\text{MHz}$, $f_{IF}=110\text{MHz}$, Lower LOCAL)

Conversion Gain, NF vs. RF frequency

$V_{MIX}=V_{LO}=2.8\text{V}$, Lower LOCAL, $f_{IF}=110\text{MHz}$,
 $P_{RF}=-25\text{dBm}$, $P_{LO}=-10\text{dBm}$

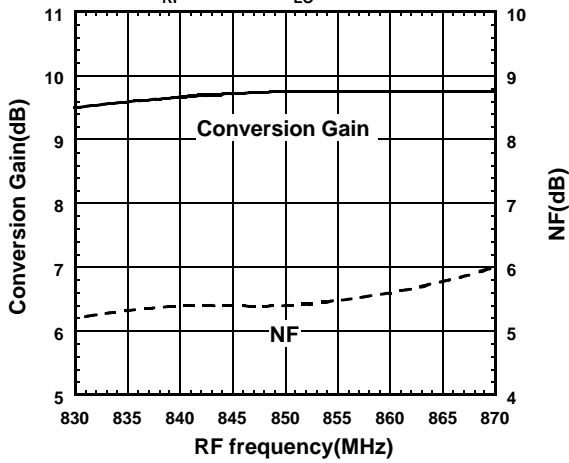

OIP3, IIP3 vs. RF frequency

$V_{MIX}=V_{LO}=2.8\text{V}$, Lower LOCAL,
 $f_{IF}=110\text{MHz}$, $P_{RF}=-25\text{dBm}$, $P_{LO}=-10\text{dBm}$

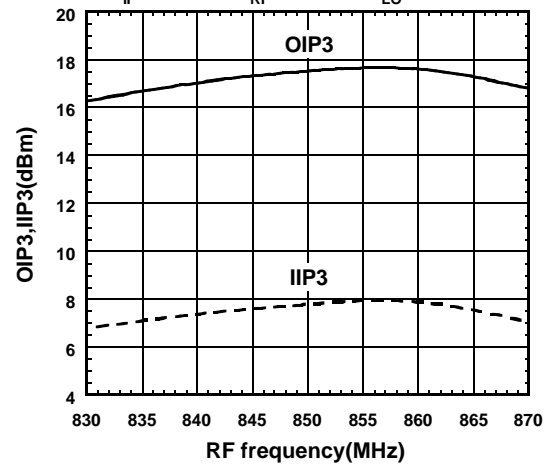

Conversion Gain, NF vs. LO Power

$V_{MIX}=V_{LO}=2.8\text{V}$, $f_{RF}=850\text{MHz}$, $f_{LO}=740\text{MHz}$,
 $f_{IF}=110\text{MHz}$, $P_{RF}=-25\text{dBm}$

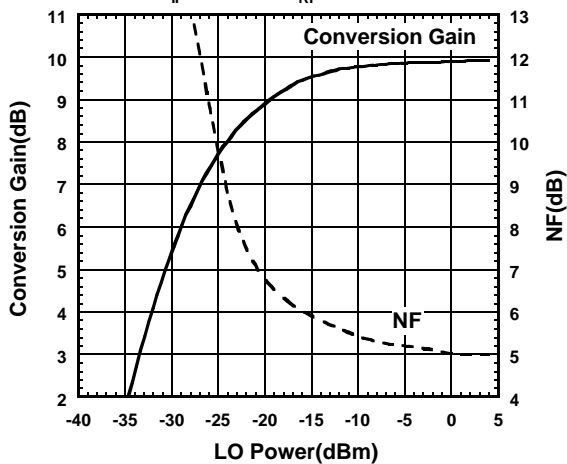

OIP3, IIP3 vs. LO Power

$V_{MIX}=V_{LO}=2.8\text{V}$, $f_{RF}=850.0+850.1\text{MHz}$,
 $f_{LO}=740\text{MHz}$, $f_{IF}=110\text{MHz}$, $P_{RF}=-25\text{dBm}$

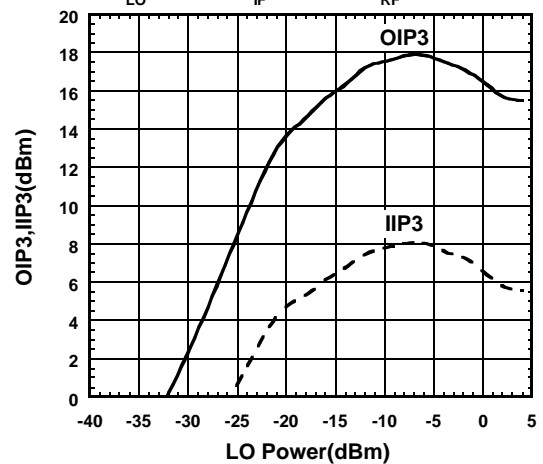

IF, IM3 vs. RF Power

$V_{MIX}=V_{LO}=2.8\text{V}$, $f_{RF}=850.0+850.1\text{MHz}$,
 $f_{LO}=740\text{MHz}$, $f_{IF}=110\text{MHz}$, $P_{LO}=-10\text{dBm}$

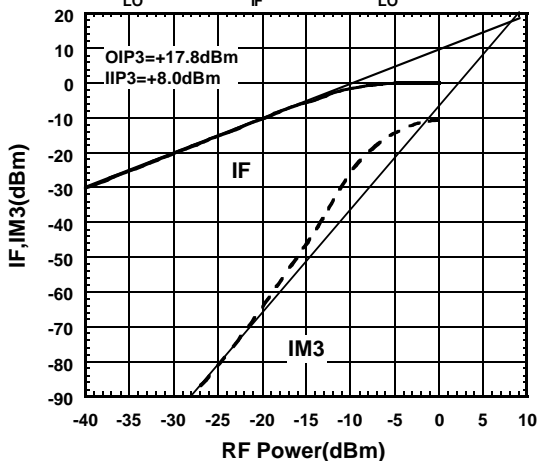

Isolation vs. LO frequency

$V_{MIX}=V_{LO}=2.8\text{V}$, $P_{LO}=-10\text{dBm}$

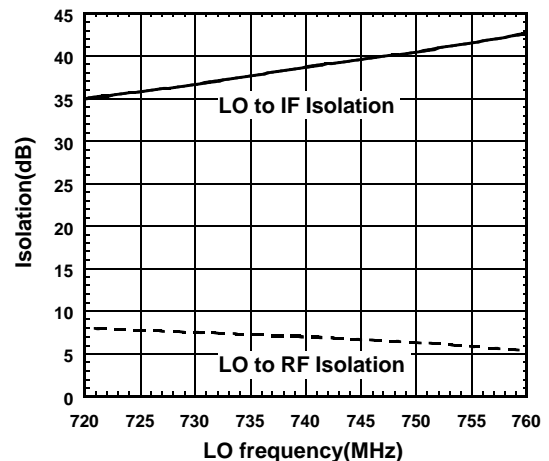

■ TYPICAL CHARACTERISTICS ($f_{RF}=830\sim 870\text{MHz}$, $f_{IF}=110\text{MHz}$, Lower LOCAL)

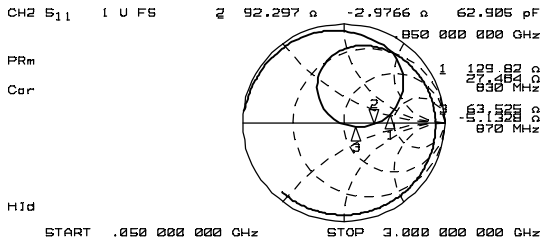
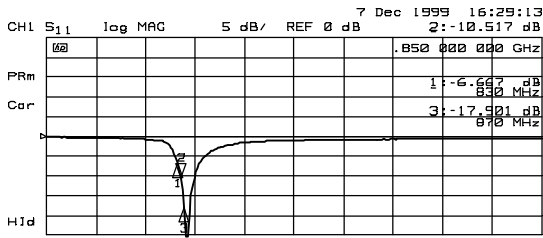

RFIN port Impedance

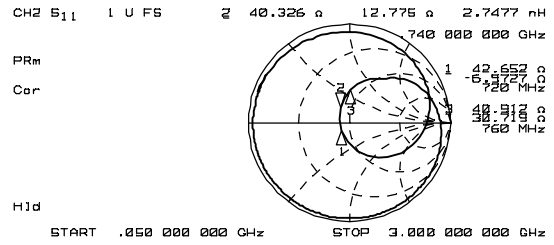
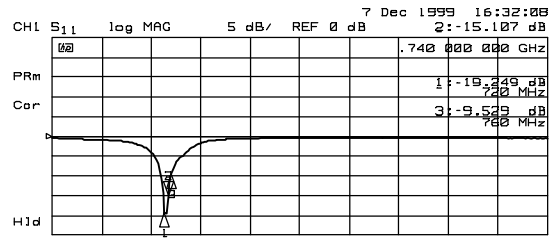

LOIN port Impedance

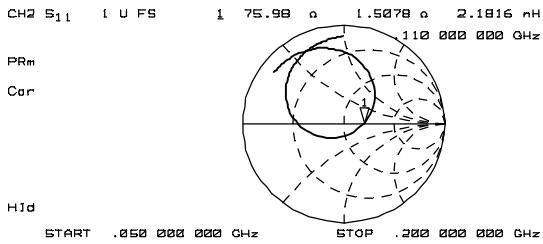
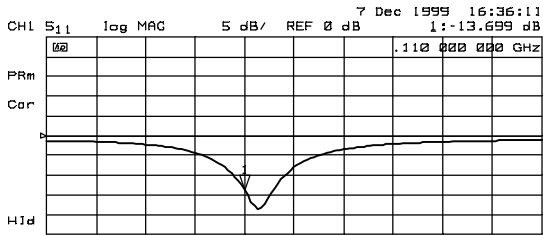

IFOUT port Impedance

NJG1557KB2

■ TYPICAL CHARACTERISTICS ($f_{RF}=830\sim 870\text{MHz}$, $f_{IF}=110\text{MHz}$, Lower LOCAL)

Conversion Gain vs. RF frequency

$V_{MIX}=V_{LO}=2.8\text{V}$, Lower LOCAL, $f_{IF}=110\text{MHz}$,
 $P_{RF}=-25\text{dBm}$, $P_{LO}=-10\text{dBm}$

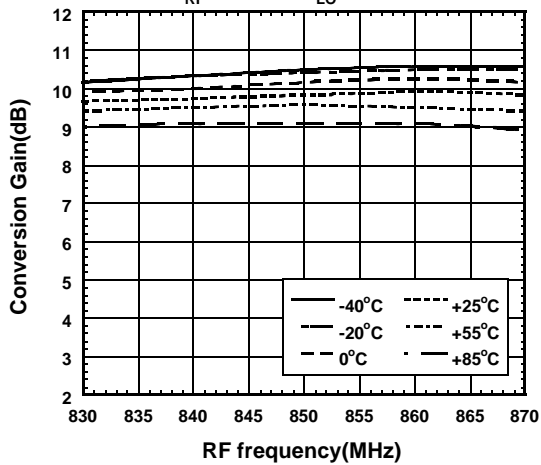

NF vs. RF frequency

$V_{MIX}=V_{LO}=2.8\text{V}$, Lower LOCAL,
 $f_{IF}=110\text{MHz}$, $P_{LO}=-10\text{dBm}$

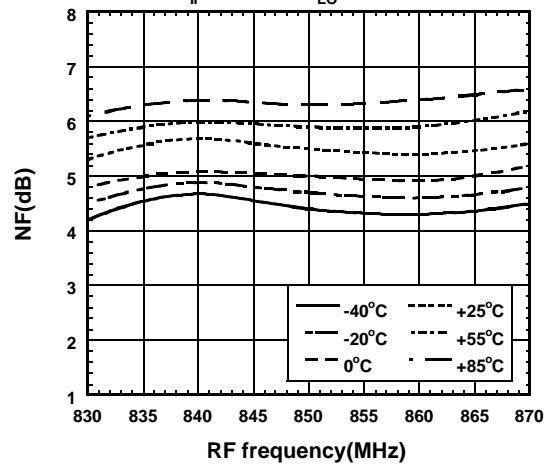

OIP3 vs. RF frequency

$V_{MIX}=V_{LO}=2.8\text{V}$, Lower LOCAL, $f_{IF}=110\text{MHz}$,
 $P_{RF}=-25\text{dBm}$, $P_{LO}=-10\text{dBm}$

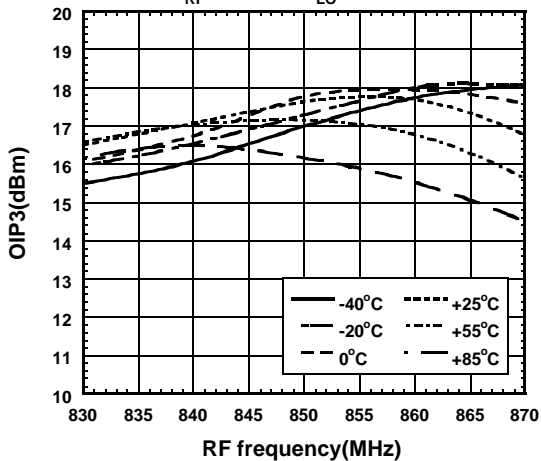

IIP3 vs. RF frequency

$V_{MIX}=V_{LO}=2.8\text{V}$, Lower LOCAL, $f_{IF}=110\text{MHz}$,
 $P_{RF}=-25\text{dBm}$, $P_{LO}=-10\text{dBm}$

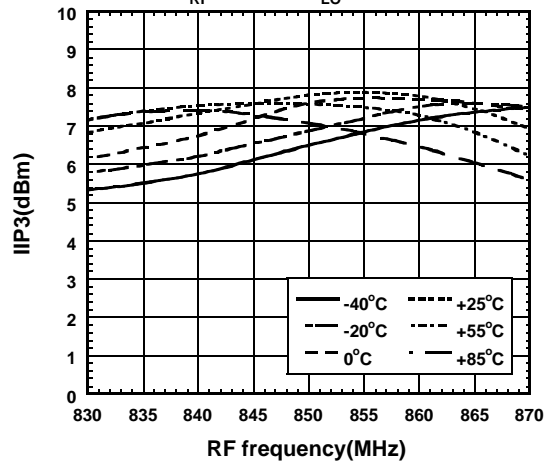

Equations of OIP3 and IIP3

$$\text{OIP3} = (3 \times \text{IF} - \text{IM3}) / 2 \quad (1)$$

$$\text{IIP3} = \text{OIP3} - \text{Gc} \quad (2)$$

IF: IF Power (dBm)

IM3: IM3 Power (dBm)

Gc: Conversion Gain (dB)

@ $P_{RF} = -25\text{dBm}$

* The values of OIP3 and IIP3 shown in typical characteristics are calculated from equation (1), (2)

TEST CIRCUIT

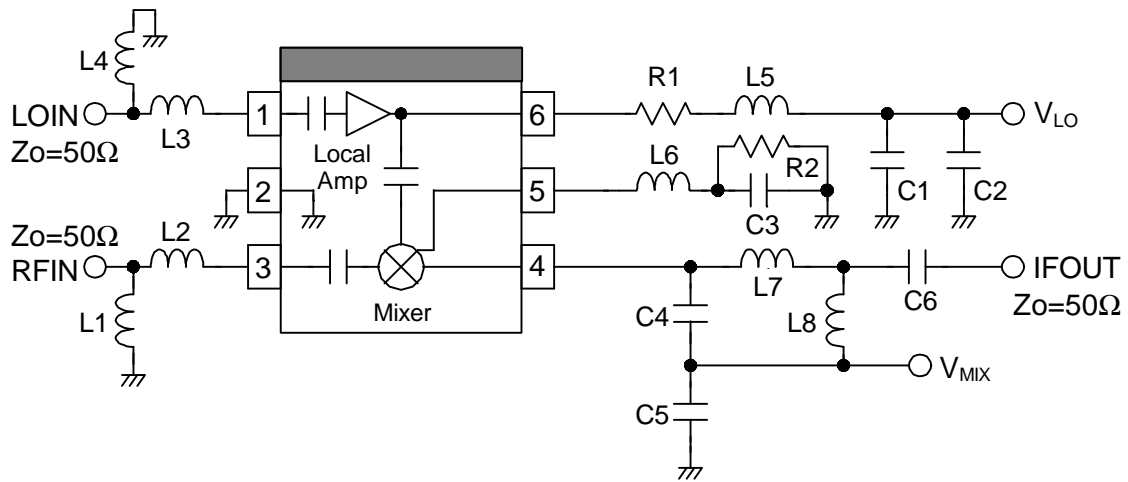

RECOMMENDED PCB DESIGN

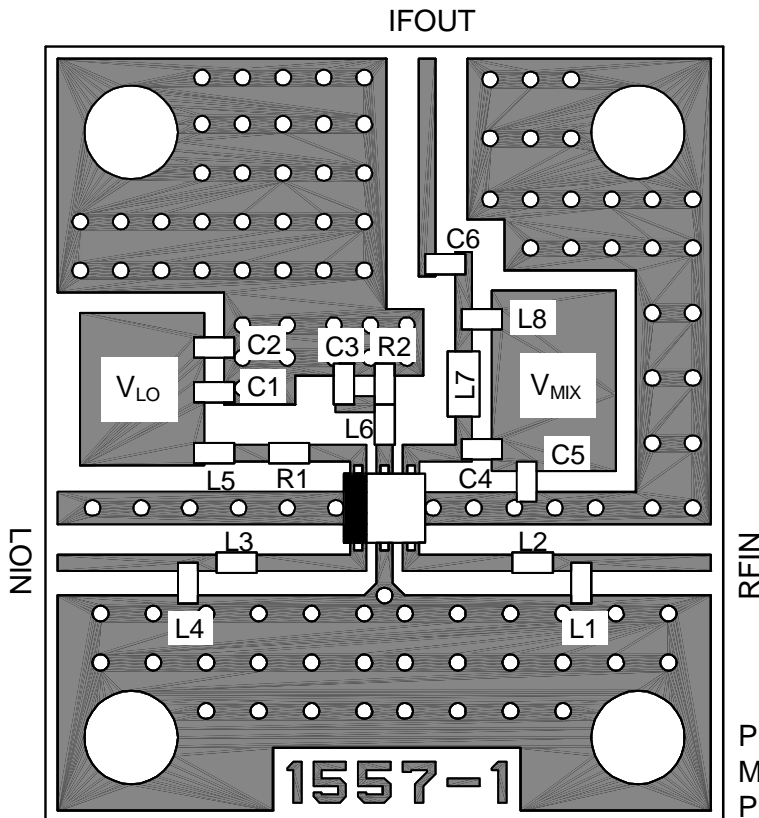

PCB: FR4 t=0.2mm
 Microstrip Line Width=0.4mm($Z_0=50\Omega$)
 PCB Size: 16.7x19.1mm

PRECAUTIONS

- [1] Please place R1 and L5 close to VLo terminal (6th pin).
- [2] Please place C1, C2 close to L5.
- [3] Please place C5 close to C4.

TABLE CHIP PARTS LIST

Parts ID	Lower LOCAL	REMARKS
	$f_{RF}=850\text{MHz}$ $f_{LO}=740\text{MHz}$ $f_{IF}=110\text{MHz}$	
L1	5.6nH	TAIYO-YUDEN (HK1005)
L2	12nH	TAIYO-YUDEN (HK1005)
L3	39nH	TAIYO-YUDEN (HK1005)
L4	22nH	TAIYO-YUDEN (HK1005)
L5	33nH	TAIYO-YUDEN (HK1005)
L6	1.0nH	TAIYO-YUDEN (HK1005)
L7	120nH	TAIYO-YUDEN (HK1608)
L8	56nH	TAIYO-YUDEN (HK1005)
C1	100pF	MURATA (GRM36)
C2	1000pF	MURATA (GRM36)
C3	47pF	MURATA (GRM36)
C4	11pF	MURATA (GRM36)
C5	1000pF	MURATA (GRM36)
C6	1000pF	MURATA (GRM36)
R1	27 Ω	1005 Size
R2	82 Ω	1005 Size

MEASURING BLOCK DIAGRAM

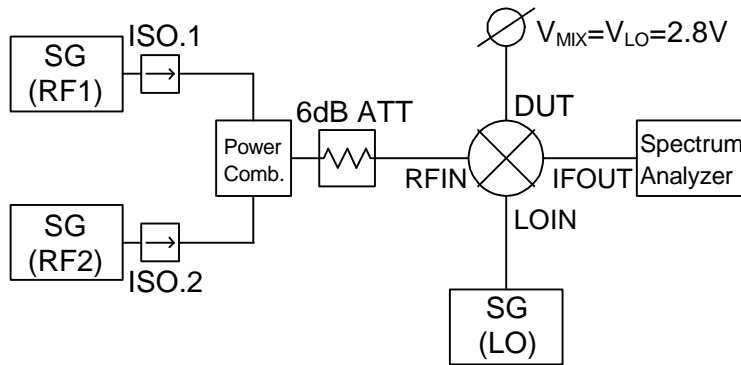

I.F., IM3 Measuring Block Diagram

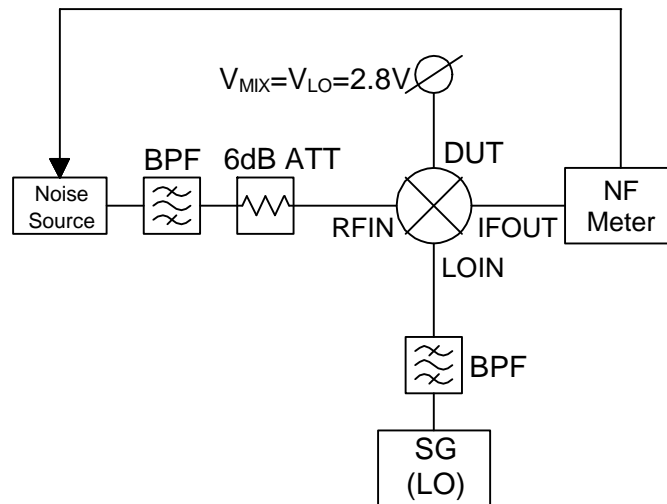

Noise Figure Measuring Block Diagram

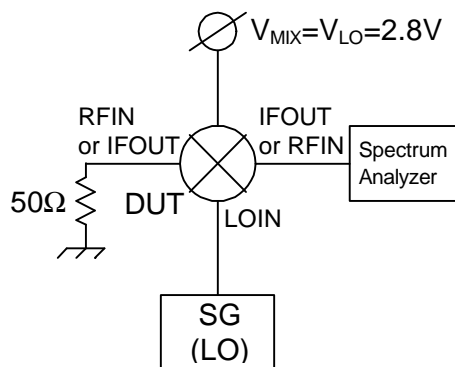

Isolation Measuring Block Diagram

NJG1557KB2

PACKAGE OUTLINE (FLP6-B2)

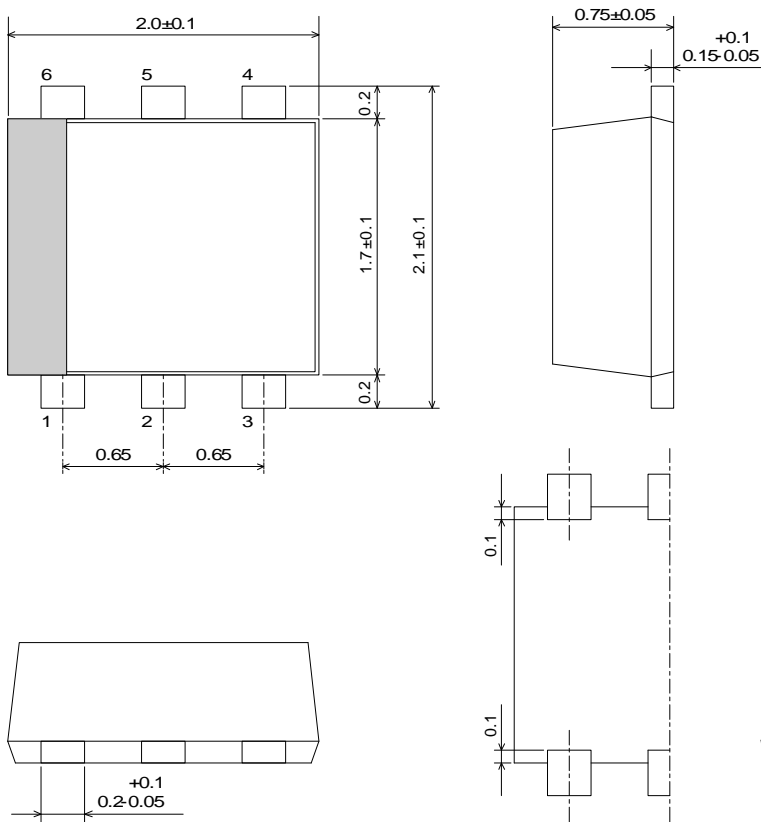

Lead material	: Copper
Lead surface finish	: Solder plating
Molding material	: Epoxy resin
Unit	: mm
Weight	: 6.5mg

Cautions on using this product

This product contains Gallium-Arsenide (GaAs) which is a harmful material.

- Do NOT eat or put into mouth.
- Do NOT dispose in fire or break up this product.
- Do NOT chemically make gas or powder with this product.
- To waste this product, please obey the relating law of your country.

[CAUTION]

The specifications on this databook are only given for information, without any guarantee as regards either mistakes or omissions. The application circuits in this databook are described only to show representative usages of the product and not intended for the guarantee or permission of any right including the industrial rights.

This product may be damaged with electric static discharge (ESD) or spike voltage. Please handle with care to avoid these damages.