

LOW POWER SWITCHING REGULATOR

■ GENERAL DESCRIPTION

The NJM2352 is the industry's first monolithic low power switching regulators available in an 8-lead mini-DIP, and designed specifically for battery operated instruments. They each contain a 1.3V temperature compensated bandgap reference, adjustable free running oscillator, voltage comparator, low battery detection circuitry, and a 200mA switch transistor with all of the functions required to make a complete low power switching regulator.

These regulators can achieve up to 80% efficiency in most applications while being able to operate over a wide input supply voltage range, 2.6V to 24V, at a very low quiescent drain of 280 μ A.

The NJM2352 can be used as a building block in three basic applications: step-up, step-down and inverting.

■ PACKAGE OUTLINE

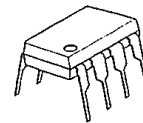

NJM2352D

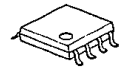

NJM2352M

■ FEATURES

- Operating Voltage (2.6V~24.0V)
- Low Operating Current
- Internal Low Voltage Detect Circuit
- Pulse Width Modulation Control Circuit
- Package Outline DIP8, DMP8
- Bipolar Technology

■ BLOCK DIAGRAM

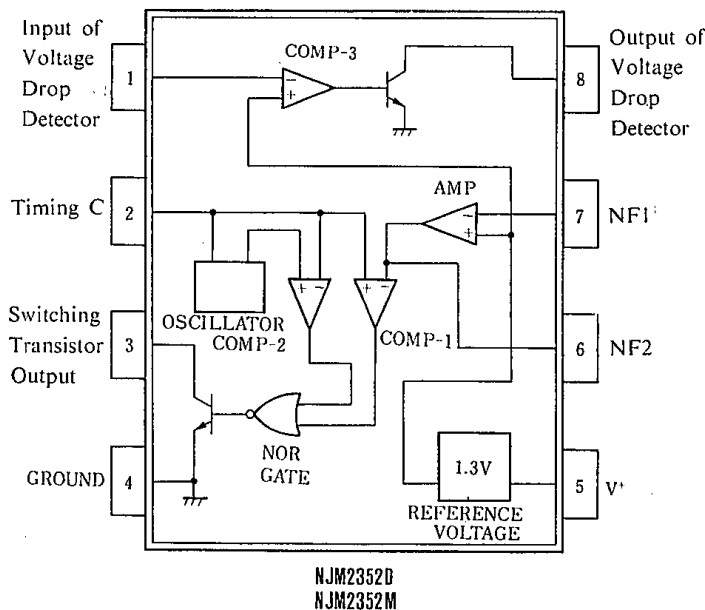

6

■ ABSOLUTE MAXIMUM RATINGS

(Ta=25°C)

PARAMETER	SYMBOL	RATINGS	UNIT
Supply Voltage	V ⁺	24	V
Power Dissipation	P _D	(DIP8) 500 (DMP8) 300	mW
Operating Temperature Range	T _{opr}	-40~+85	°C
Storage Temperature Range	T _{stg}	-40~+125	°C

■ ELECTRICAL CHARACTERISTICS

DC Electrical Characteristics (V⁺=6V, Ta=25°C)

PARAMETER	SYMBOL	TEST CONDITION	MIN.	TYP.	MAX.	UNIT
Operating Current (1)	I _{cc} (1)		—	275	350	μA
Operating Current (2)	I _{cc} (2)	V ⁺ =24V	—	400	550	μA
Reference Voltage	V _{REF}		1.24	1.31	1.38	V
Sw. Saturation Voltage	V _{SW}	I _{SW} =100mA	—	0.2	0.4	V
Sw. Current	I _{SW}	V _{SW} =0.4V	100	200	—	mA
Sw. Leakage Current	I _{SW0}	V _ⓐ PIN=24V	—	0.1	10	μA
Operating Frequency	F _O	C _X =50pF	40	50	60	kHz
Low Battery Output Current	I _{LED} (L)	V _ⓐ PIN=1.1V, V _ⓑ PIN=0.4V	300	800	—	μA
Low Battery Output Leakage Current	I _{LED} (H)	V _ⓐ PIN=1.4V, V _ⓑ PIN=6V	—	0.1	5	μA

AC Electrical Characteristics (STEP-UP, Ta=25°C)

PARAMETER	SYMBOL	TEST CONDITION	MIN.	TYP.	MAX.	UNIT
Output Voltage (9V Set)	V _{O(9)}	V ⁺ =4.5V, I _O =10mA	8.51	9.00	9.49	V
Load Regulation (9V Set)	ΔV _{O-I_O} (9)	V ⁺ =4.5V, I _O =2~17mA	—	100	200	mV
Line Regulation (9V Set)	ΔV _{O-V_{IN}} (9)	V ⁺ =4.5~8.1V, I _O =10mA	—	50	200	mV
Output Voltage (5V Set)	I _{LED} (L)	V ⁺ =2.6V, I _O =10mA	4.72	5.00	5.28	V
Output Voltage (24V Set)	I _{LED} (H)	V ⁺ =12V, I _O =4mA	22.7	24.0	25.3	V

■ TEST CIRCUIT

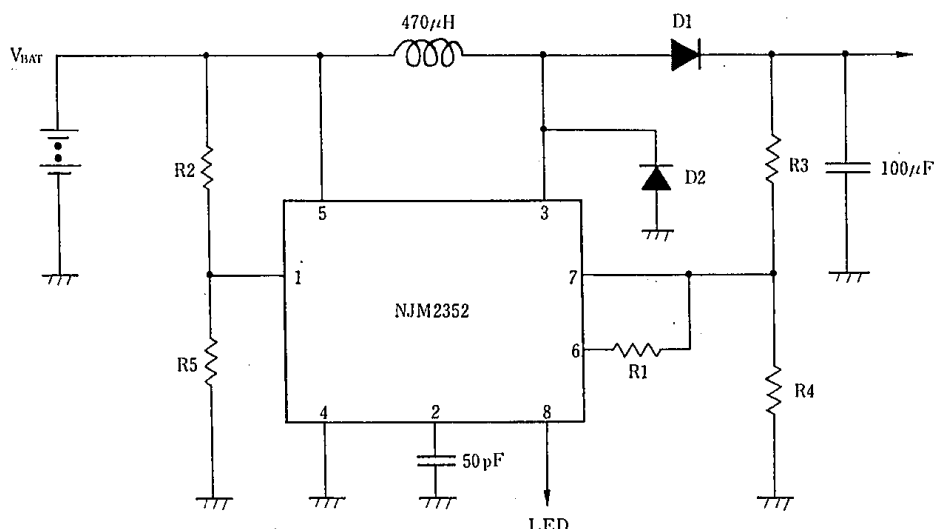

D2: SBD (EK-14)

■ TYPICAL APPLICATION

1. Step-Up Switching Regulator (Low Current)

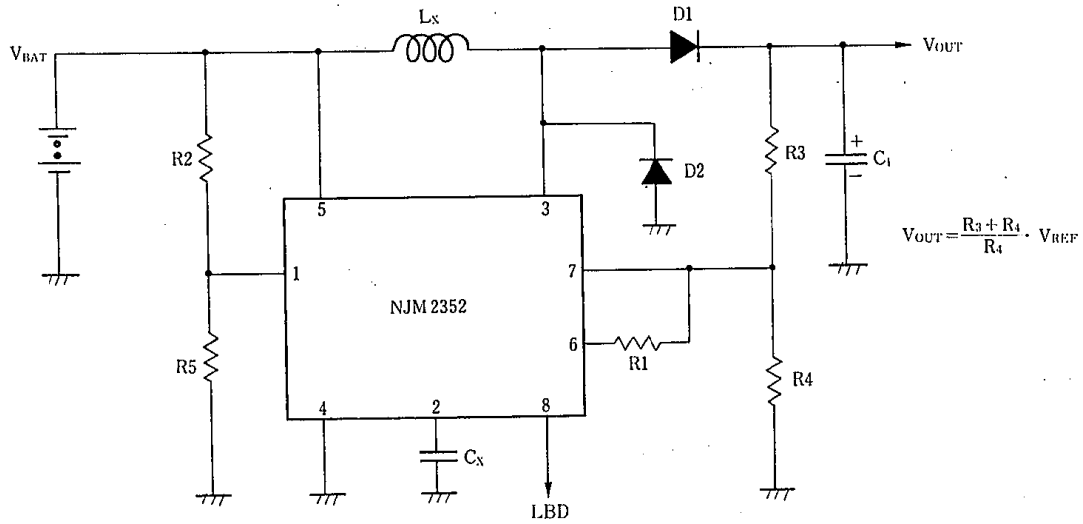

2. Step-Up Switching Regulator (High Current)

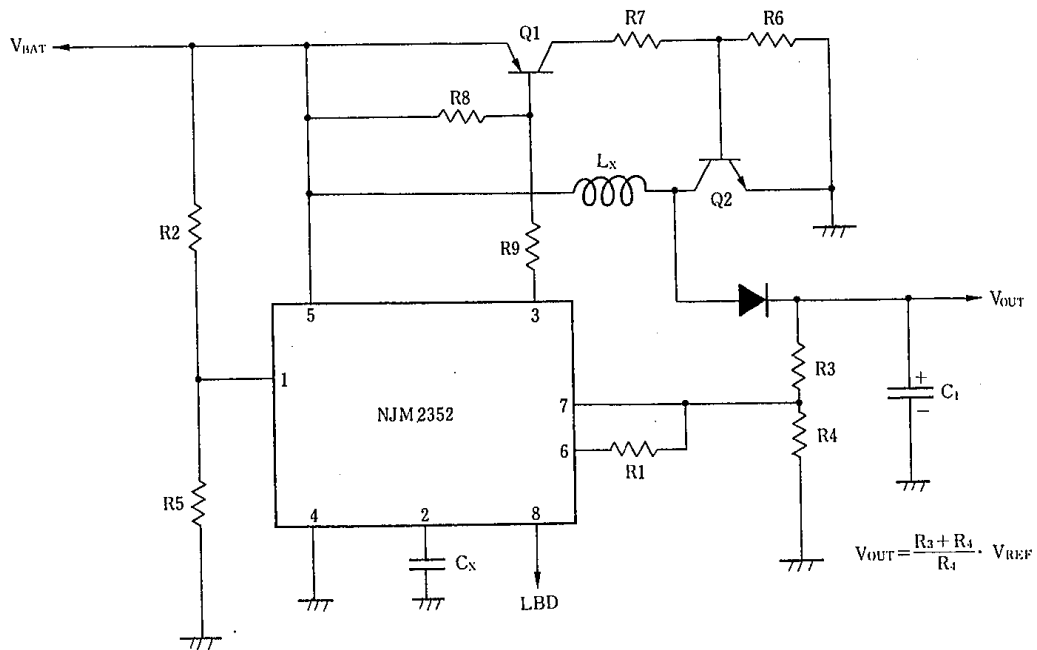

■ TYPICAL APPLICATION

3. Step-Down Switching Regulator

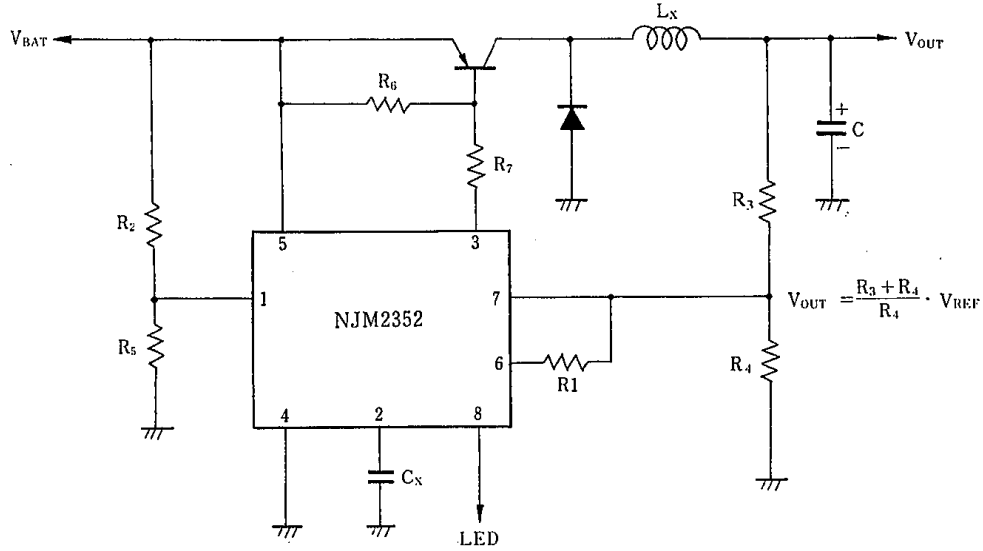

4. Inverting Switching Regulator

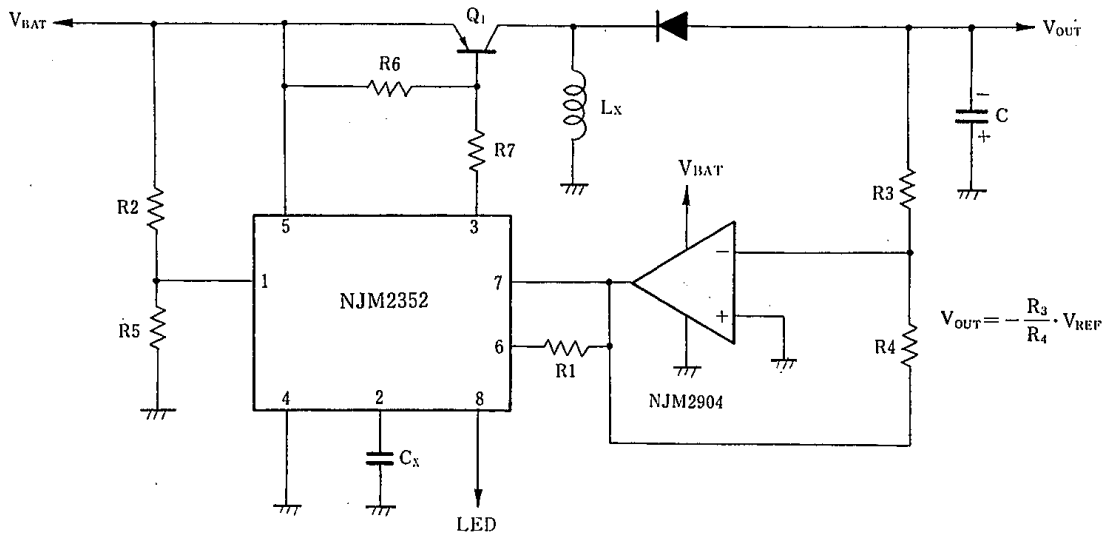

6

DESIGN EQUATIONS

Component	Step Up	Step Down	Inverting
R ₁	$R_1 = R_3 \times 10$	$R_1 = R_3 \times 10$	$R_1 = R_3 \times 10$
R ₂	$\frac{V_{TH} - V_{REF}}{5\mu A}$	$\frac{V_{TH} - V_{REF}}{5\mu A}$	$\frac{V_{TH} - V_{REF}}{5\mu A}$
R ₃	$\frac{V_{OUT} - V_{REF}}{I_1}$	$\frac{V_{OUT} - V_{REF}}{I_1}$	$\frac{V_{OUT}}{I_1}$
R ₄	$\frac{V_{REF}}{I_1}$	$\frac{V_{REF}}{I_1}$	$\frac{V_{REF}}{I_1}$
R ₅	261Ω	261Ω	261Ω
C _x (pF)	$\frac{2.14 \times 10^6}{F_o \text{ (Hz)}}$	$\frac{2.14 \times 10^6}{F_o}$	$\frac{2.14 \times 10^6}{F_o}$
L _x	$\frac{0.3 \cdot V_{BAT} \cdot (V_{OUT} - V_{BAT})}{F_o \cdot I_{LOAD} \cdot V_{OUT}}$	$\frac{0.3 \cdot (V_{OUT})}{F_o \cdot I_{LOAD}}$	$\frac{0.3 \cdot V_{BAT} \cdot V_{OUT} }{F_o \cdot I_{LOAD} \cdot (V_{BAT} + V_{OUT})}$
C ₁	$\frac{0.15 \cdot I_{LOAD} \cdot (2V_{OUT} - V_{BAT})^2}{F_o \cdot V_{OUT} \cdot V_R \cdot V_{BAT}}$	$\frac{I_{LOAD}}{4F_o \cdot V_R}$	$\frac{0.15 \cdot I_{LOAD} \cdot (V_{BAT} + 2 V_{OUT})^2}{F_o \cdot V_{BAT} \cdot (V_{BAT} + V_{OUT}) \cdot V_R}$
R ₆	$\frac{35 \cdot V_{BAT}}{I_{LOAD} \cdot V_{OUT}}$	$\frac{35}{I_{LOAD}}$	$\frac{35 \cdot V_{BAT}}{I_{LOAD} \cdot (V_{BAT} + V_{OUT})}$
R ₇	$\frac{5 \cdot (V_{BAT})^2}{I_{LOAD} \cdot V_{OUT}}$	$\frac{5 \cdot V_{BAT}}{I_{LOAD}}$	$\frac{5 \cdot (V_{BAT})^2}{I_{LOAD} \cdot (V_{BAT} + V_{OUT})}$
R ₈	$\frac{350 \cdot (V_{BAT})}{I_{LOAD} \cdot V_{OUT}}$		
R ₉	$\frac{50(V_{BAT})^2}{I_{LOAD} \cdot V_{OUT}}$		

$I_1 = 100\mu A$

V_{TH} : low battery detection voltage.

Ripple Voltage at V_R : $I_1 = 50 - 100\mu A$.

■ DESCRIPTION

The NJM2352 is a micro-power switching regulator control IC suitable for a equipment of battery operation and may be used as step-up, step-down and inverting regulators.

The NJM2352 contains a reference, oscillator, amplifier, comparator, detector of input voltage drop and switching transistor. The output voltage is controlled by PWM method.

The NJM2352 applies a bandgap as a reference voltage. The oscillator is composed of putting one capacitance (C_x) to the pin 2. The amplifier is 80dB open-loop voltage gain and 1MHz band width. By adding adequate resistors to the pin 1, the indicating signal comes when the input voltage drops more than designed input voltage. Switching transistor is open collector.

■ TERMINAL DESCRIPTION

TERMINAL NO.	TERMINAL ITEMS	FUNCTION	INSIDE EQUIVALENT CIRCUITS
1	Input of Voltage Drop Detector	Inverting input Terminal of comparator-3. When input voltage drops than non-inverting input voltage, comparator drives indicator output transistor.	<p>The diagram shows the internal equivalent circuit of the NJM2352. It features a bandgap reference circuit (V_{REF}) and a 10 µA current source. The circuit is connected to pins 1 and 8. Pin 1 is the inverting input of a comparator, and pin 8 is the open collector output transistor. The output is connected to GND.</p>
8	Output of Voltage Drop Detector	Open collector output transistor for driving LED, LCD etc.	

■ TERMINAL DESCRIPTION

TERMINAL NO.	TERMINAL ITEMS	FUNCTION	INSIDE EQUIVALENT CIRCUITS
2	Timing C	Connecting timing for deciding oscillator frequency.	<p>The diagram shows a timing network. A current source of 10µA is connected to V+. The circuit includes two transistors, COMP-1 and COMP-2, and a network of other transistors. Terminal 2 is connected to the base of one of the transistors in the network. The circuit is connected to V+ and GND.</p>
3	Switching Transistor Output	Open collector Output of switching transistor.	<p>The diagram shows a switching transistor circuit. A NOR gate is connected to V+ through a 1k resistor. The output of the NOR gate is connected to the base of a transistor. The emitter of this transistor is connected to GND through a 200k resistor. The collector of this transistor is connected to the base of another transistor. The emitter of the second transistor is connected to GND through a 5k resistor. The collector of the second transistor is connected to terminal 3. The circuit is connected to V+ and GND.</p>
4	GROUND	Ground	
5	V+	Supply voltage terminal.	

6

■ TERMINAL DESCRIPTION

TERMINAL NO.	TERMINAL ITEMS	FUNCTION	INSIDE EQUIVALENT CIRCUITS
6	NF2	Terminal from connecting point of AMP output and COMP-1 inverting input.	
7	NF1	Inverting input of amplifier.	

6

■ PRINCIPLE OF OPERATION

The NJM2352 circuit block is shown on Fig. 1 and timing chart on Fig. 2. Function of COMP-2 is setting dead-time. At point (A) is the square wave and at point B is the triangular wave. By putting two input signals (A, B) into COMP-2, output (point C) voltage is held high level during rising period of triangular wave and the switching transistor is kept in the off condition regardless the COMP-1 output level. So the maximum duty cycle of the NJM2352 is 50%.

The COMP-1 makes on-time of switching transistor longer when the output voltage is high and shorter when it is low. Thus function of the COMP-1 is pulse wide modulation. When the AMP's output waveform is (D), COMP-1 output is like (E), and NOR GATE output becomes high level only when both inputs, (C), (E), are low, and so the falling period of triangular wave is the range of pulse width control.

Fig. 1

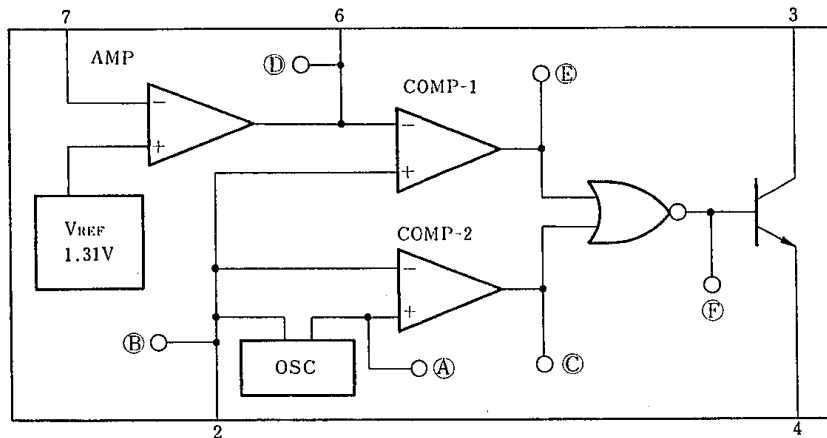
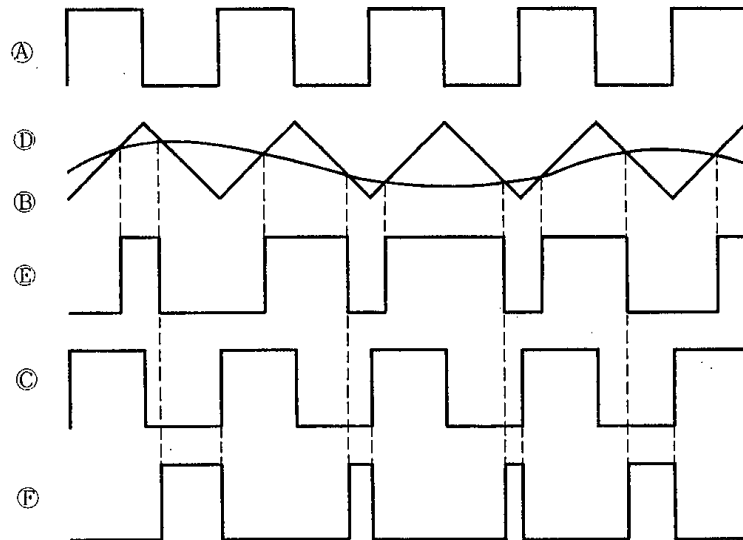

Fig. 2



6

■ **MINIMUM OPERATING VOLTAGE**

Minimum operating voltage is $V^+ \geq 2.6V$ at $25^\circ C$ and its temperature coefficient is negative. Be careful when you design. Less than this minimum operating voltage, internal switching transistor becomes on, and the surge-like high current flows into it especially in Step-Up or Inverting application.

■ **OSCILLATOR**

Oscillator frequency is decided by putting a capacitor into PIN 2. The amplitude of both square wave ㊶ and triangular wave ㊷ is between $1 V_{BE}$ and $3 V_{BE}$.

■ **AMPLIFIER**

AMP source current is $20\mu A$ max. and so the feedback resistor R_1 to be connected to PIN 6 and PIN 7 are recommended more than $100k\Omega$.

■ **SWITCHING TRANSISTOR**

When the negative voltage more than $0.5V$ absolute value based on ground level is applied, the NJM2352 may operate unordinary by reason of parasitic effect in it. And so put SBD in between PIN 3 and ground when you drive directory coil with internal switching transistor.

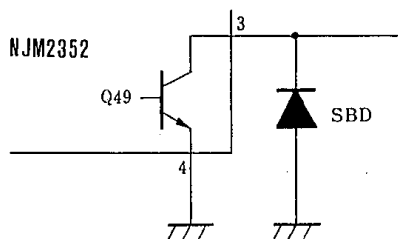

■ **DETECTION CIRCUIT OF INPUT VOLTAGE DROP**

When input voltage becomes lower than specified voltage, transistor Q_{56} switches on and indicative device like LED turns on. The specified voltage is decided by internal reference voltage and outer resistors ratio.

$$V_{TH} = V_{REF}(1 + R2/R5) + R2 \times 0.5\mu A$$

When \ominus input voltage becomes lower than \oplus input voltage, PIN 1 of COMP-3 sinks about $1\mu A$ and thus prevents chattering. Transistor Q_{56} becomes off condition when PIN 1 voltage is lower than about $0.2V$. It is recommendable to put about $1\mu F$ to PIN 1 in actual application to avoid switching noise.

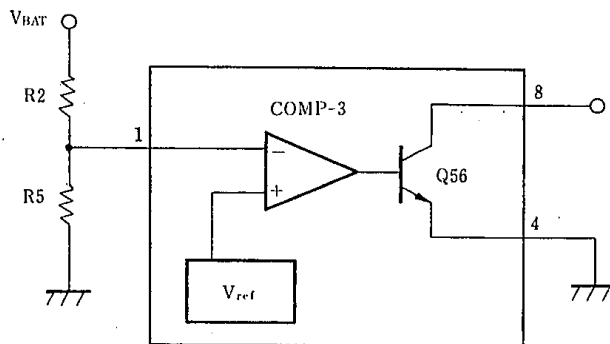

6

■ EFFICIENCY

Efficiency is shown below.

$$\text{Step Up} = \frac{V_{IN} - V_S}{V_{IN}} \times \frac{V_{OUT}}{V_{OUT} + V_D - V_S}$$

$$\text{Step Down} = \frac{V_{IN} - V_S + V_D}{V_{IN}} \times \frac{V_{OUT}}{V_{OUT} + V_D}$$

$$\text{Inverting} = \frac{V_{IN} - V_S}{V_{IN}} \times \frac{|V_{OUT}|}{|V_{OUT}| + V_D}$$

V_S : Voltage Drop based on Switching Transistor On-Resistance.

V_D : Diode Forward Voltage Drop.

If V_S and V_D are low, efficiency increase. Also speed of switching transistor and diode, series resistance of L will affect to it. Example is shown on typical characteristic graph.

■ TEST CIRCUIT 2(V_{OUT}:9V)

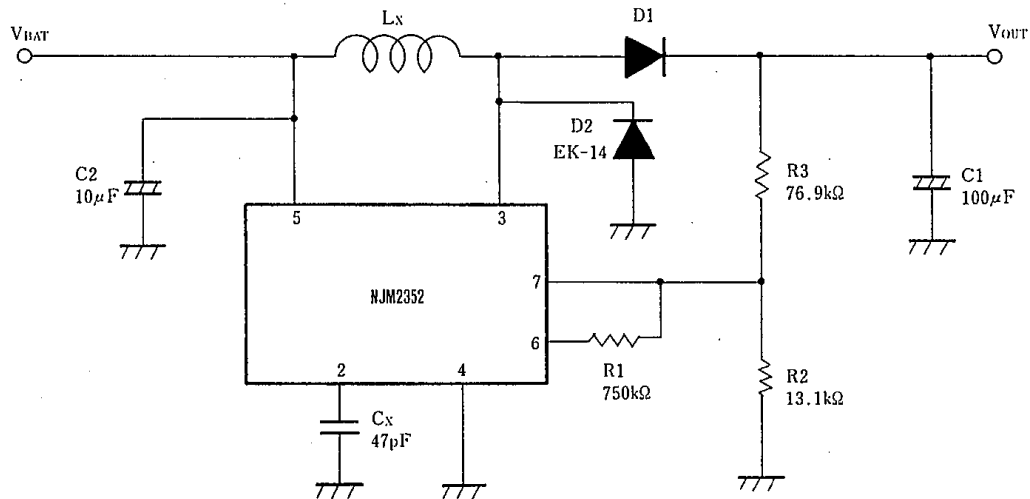

■ PARAMETER

- D1
EK-14
IS1588
- $LX=470\mu H$
L1 : Internal Resistance=0.2 Ω
L2 : Internal Resistance=2 Ω
L3 : Internal Resistance=7 Ω

■ TYPICAL CHARACTERISTICS

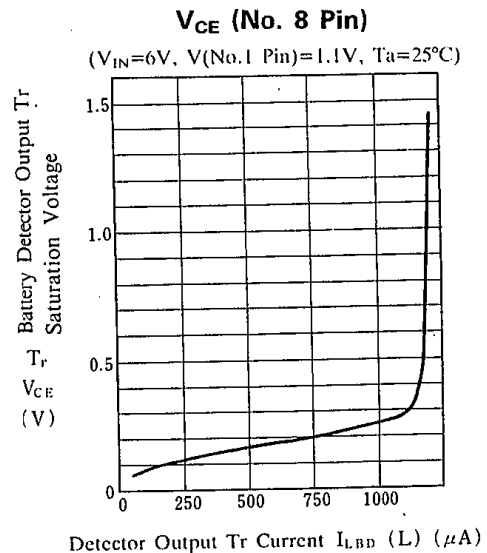
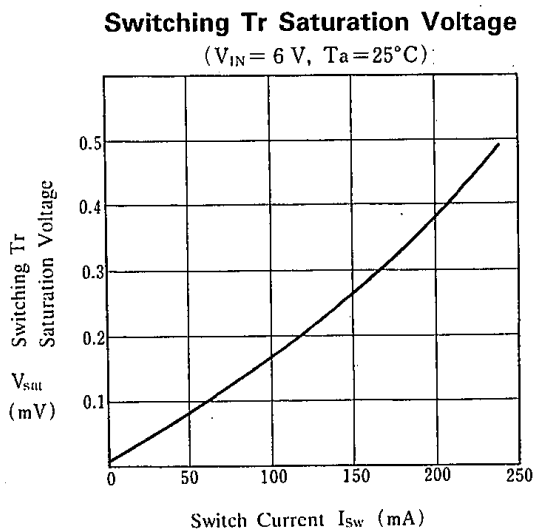
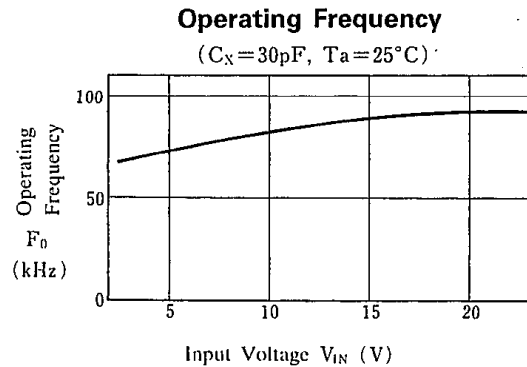
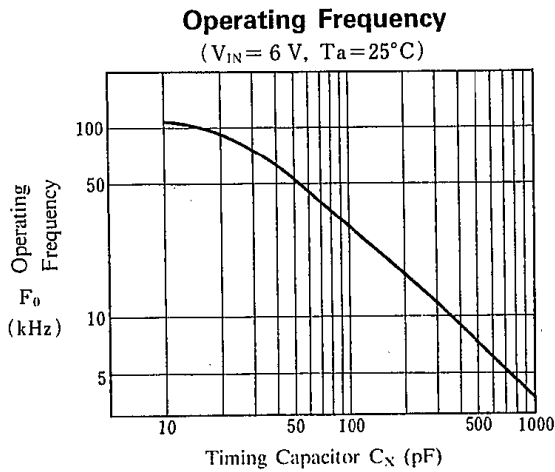
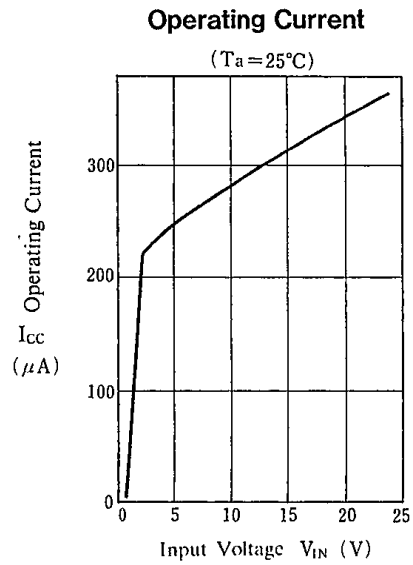
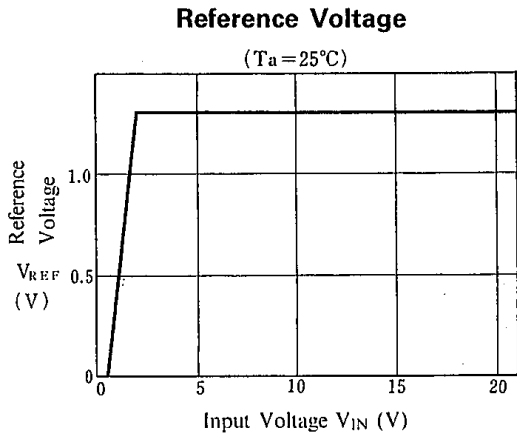

■ TYPICAL CHARACTERISTICS

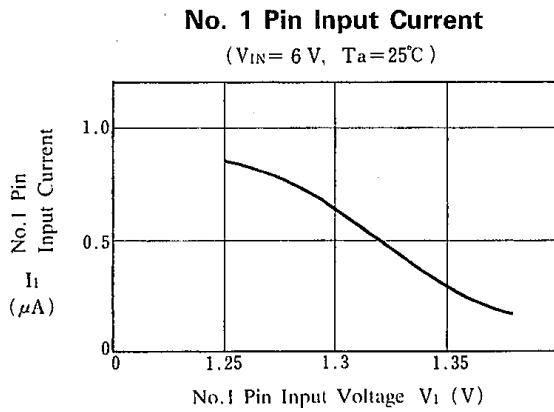
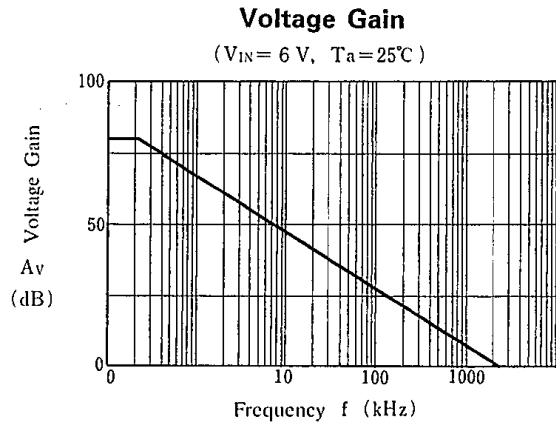
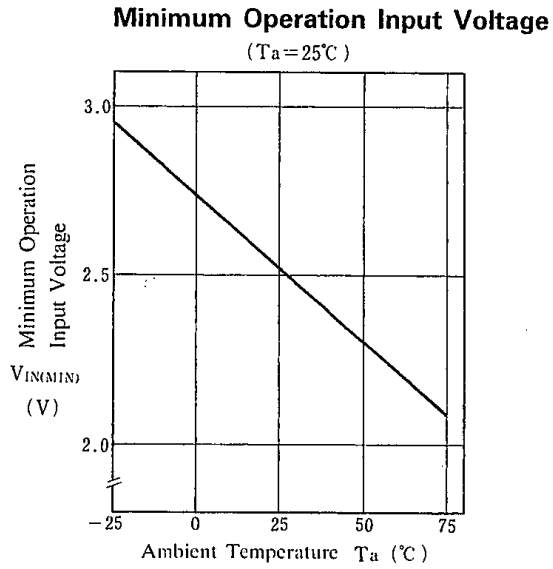

6

■ TYPICAL CHARACTERISTICS (APPLICATION)

Output Voltage

($I_L = 10\text{mA}$, $V_O = 9\text{V}$, $L_X = 470\mu\text{H}$,
 $C_X = 50\text{pF}$, $C_1 = 100\mu\text{F}$, $T_a = 25^\circ\text{C}$)

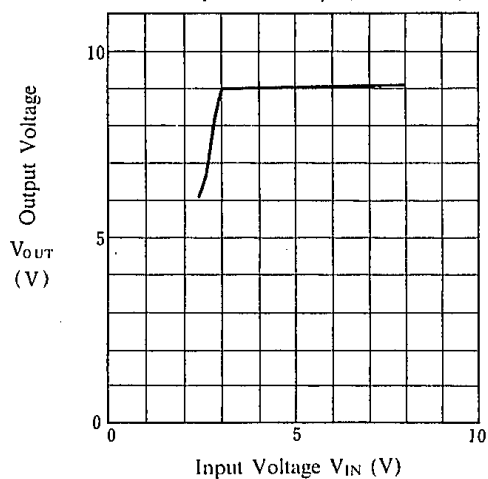

Efficiency

($I_L = 10\text{mA}$, $V_O = 9\text{V}$, $L_X = 470\mu\text{H}$,
 $C_X = 50\text{pF}$, $C_1 = 100\mu\text{F}$, $T_a = 25^\circ\text{C}$)

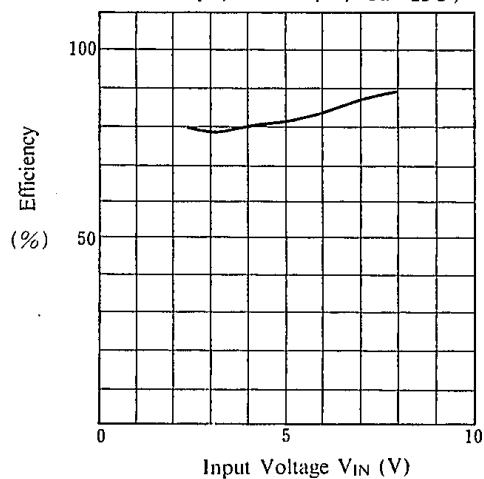

Output Voltage

($L_X = 470\mu\text{H}$, $C_X = 20\text{pF}$, $C_1 = 100\mu\text{F}$,
 $V_O = 24\text{V}$, $T_a = 25^\circ\text{C}$)

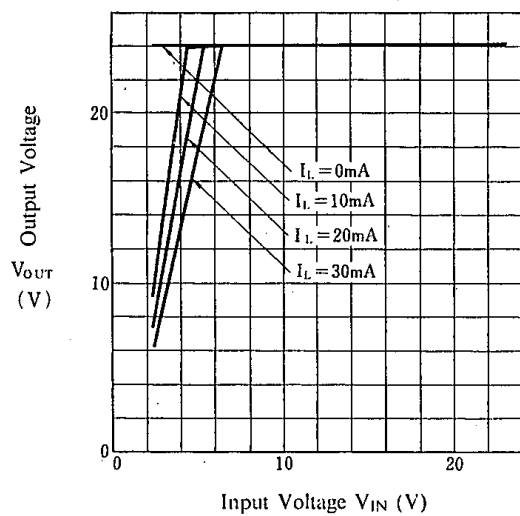

Output Voltage

($L_X = 470\mu\text{H}$, $C_X = 50\text{pF}$, $C_1 = 100\mu\text{F}$, $V_O = 5\text{V}$,
 $T_a = 25^\circ\text{C}$)

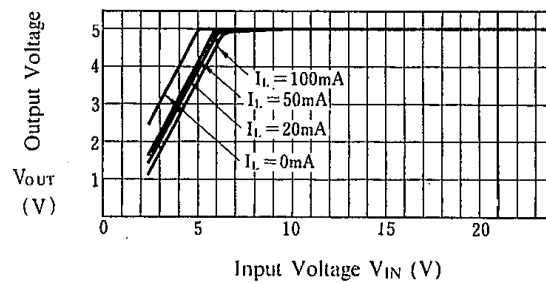

■ TYPICAL CHARACTERISTICS (Test Circuits 2)

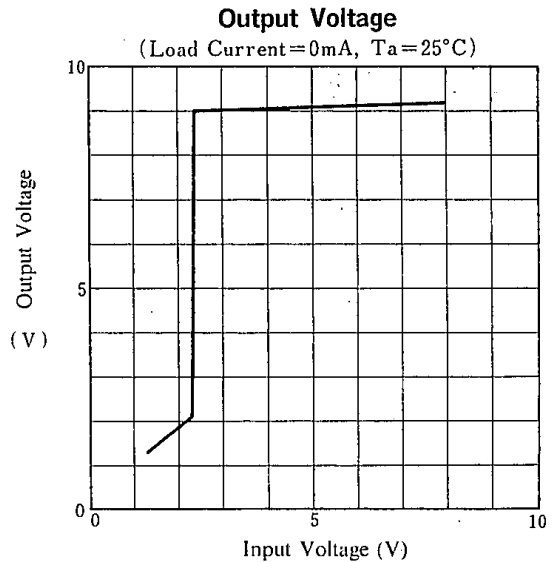
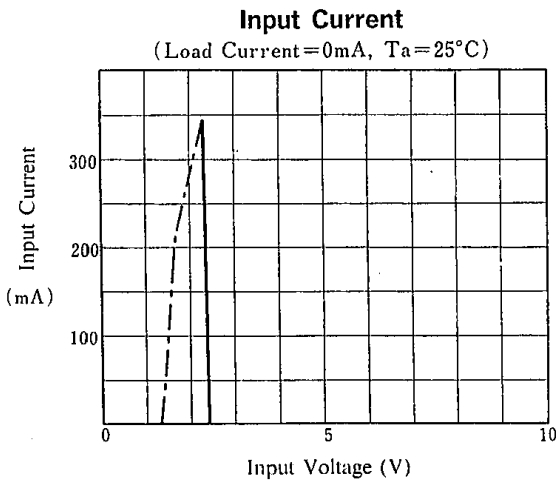
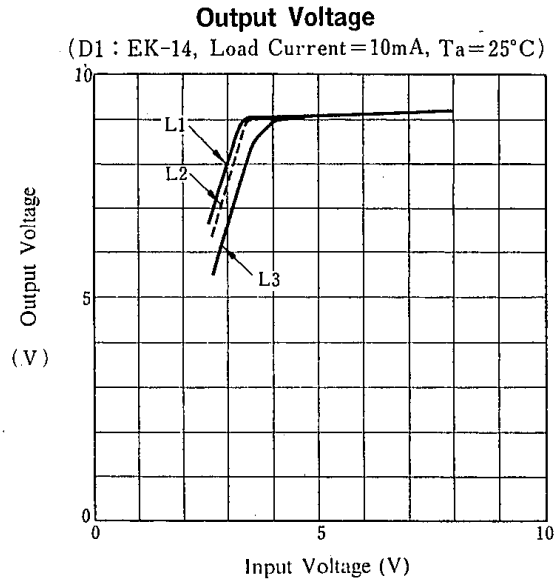
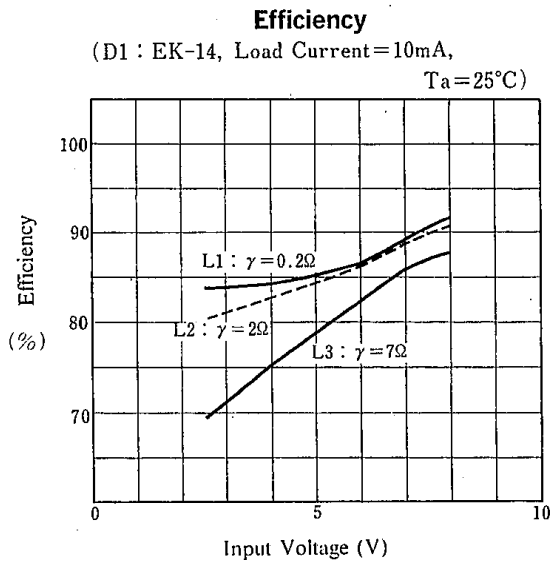
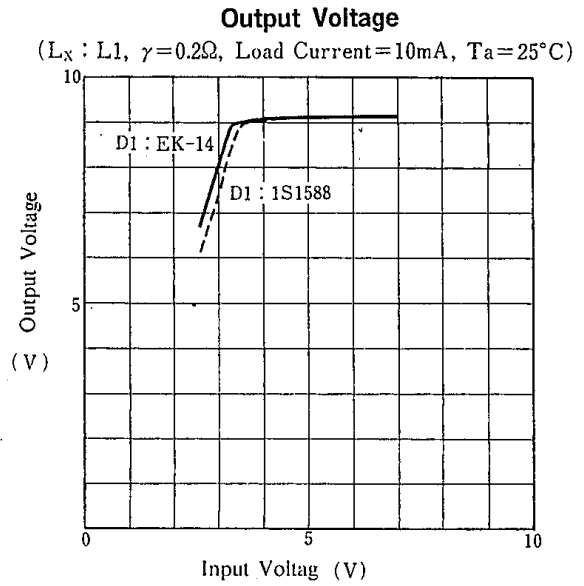
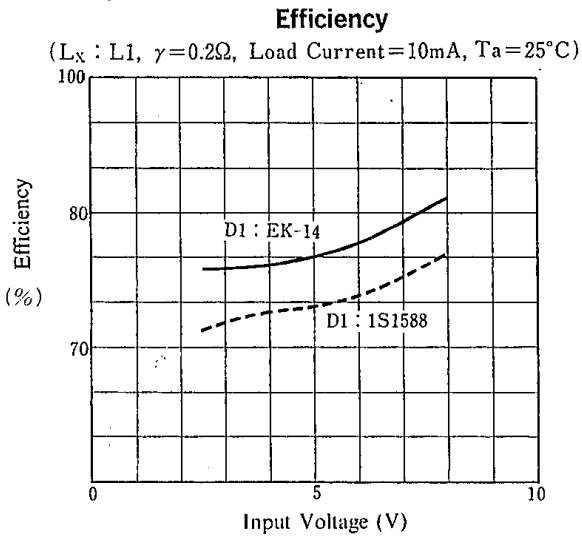

MEMO

[CAUTION]

The specifications on this databook are only given for information, without any guarantee as regards either mistakes or omissions. The application circuits in this databook are described only to show representative usages of the product and not intended for the guarantee or permission of any right including the industrial rights.