

PRELIMINARY

4•3/4 DIGIT SINGLE CHIP DIGITAL MULTIMETER LSI

GENERAL DESCRIPTION

The **NJU9214** is a 4•3/4 digits single chip digital multimeter LSI with 42 segments bargraph display.

The **NJU9214** realizes high precision of $\pm 40,000$ counts measurement by the NJRC original dual-slope A to D converter and realizes also quick response bargraph display and auto-ranging by another high speed dual-slope A to D converter.

The input attenuator part is simplified because the resistor for resistance measurement is applied for voltage bleeder resistor.

Furthermore, the **NJU9214** realizes root-mean-square measurement for AC voltage and current by connecting a External RMS-DC Converter, and Data output by the on chip RS-232C interface circuit.

The **NJU9214** is suitable for high precision and high performance multimeter.

PACKAGE OUTLINE

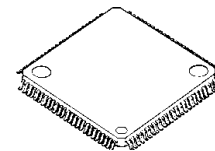

NJU9214FG1

FEATURES

- 4•3/4 Digit Display (Available for UP to $\pm 39,999$ Display)
- 42 Segments Quick Response Bargraph Display
- NJRC Original Dual-Slope A to D Converter ($\pm 40,000$ Counts)
- High Speed Dual-Slope A to D Converter (± 400 Counts)
- Quick Response Auto-Ranging (20times/sec)
- Frequency/Capacitance/Tachometer/Adapter Measurement
- Root-Mean-Square Measurement by connecting a External RMS-DC Converter
- External Relay Driving
- Data Memory/Data Hold/Relative Display/MAX, MIN Display
- Power-on Initializing
- Auto Power-off
- Battery Life Detector
- Rotary/Push SW Mode Selection
- 1/4 Duty LCD Display Driver
- Piezo Buzzer Direct Driving
- RS-232C Interface
- External Reference Input required
- Low Operating Current
- C-MOS Technology
- Package Outline TQFP100

BLOCK DIAGRAM

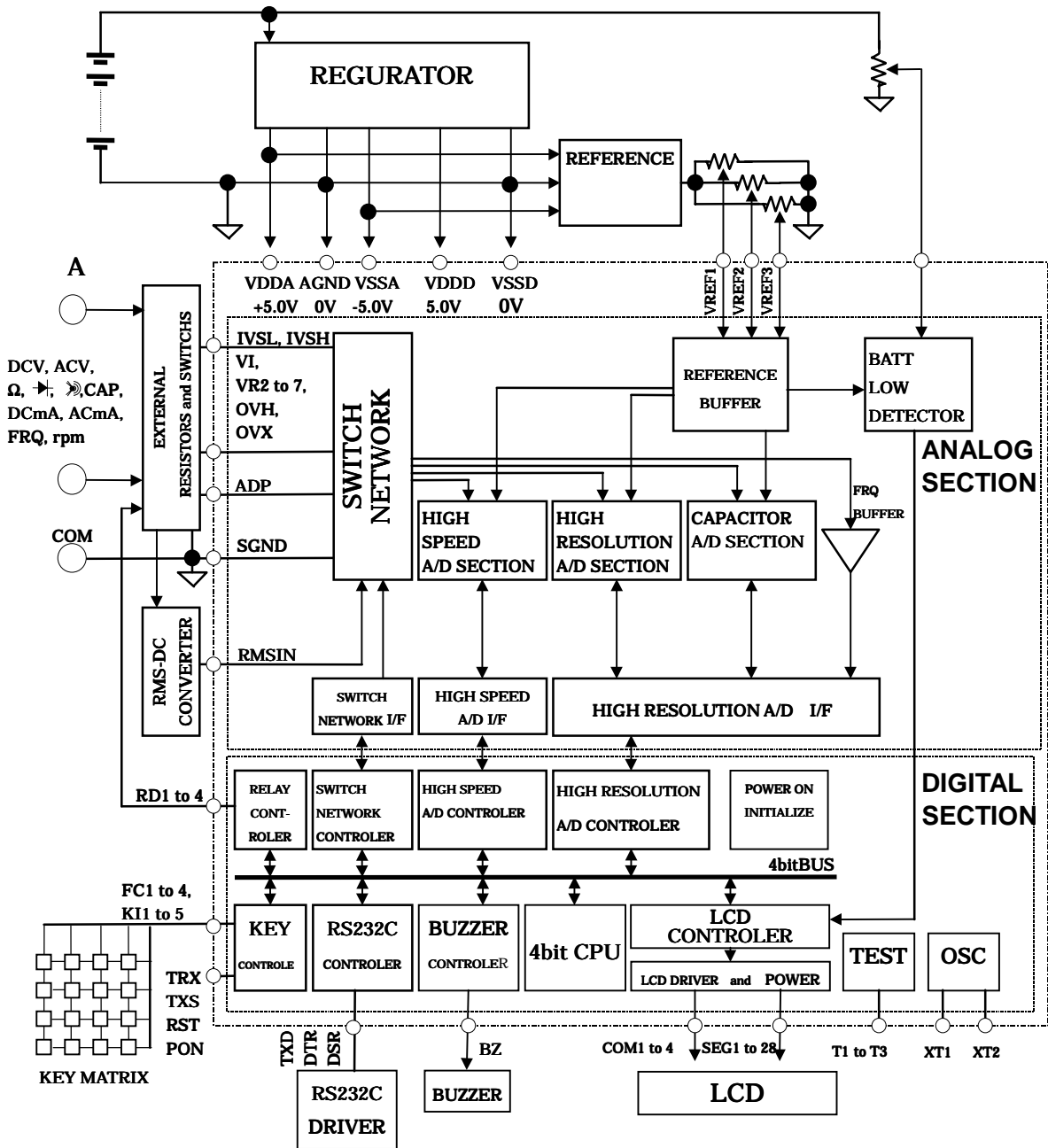

PIN CONFIGURATION

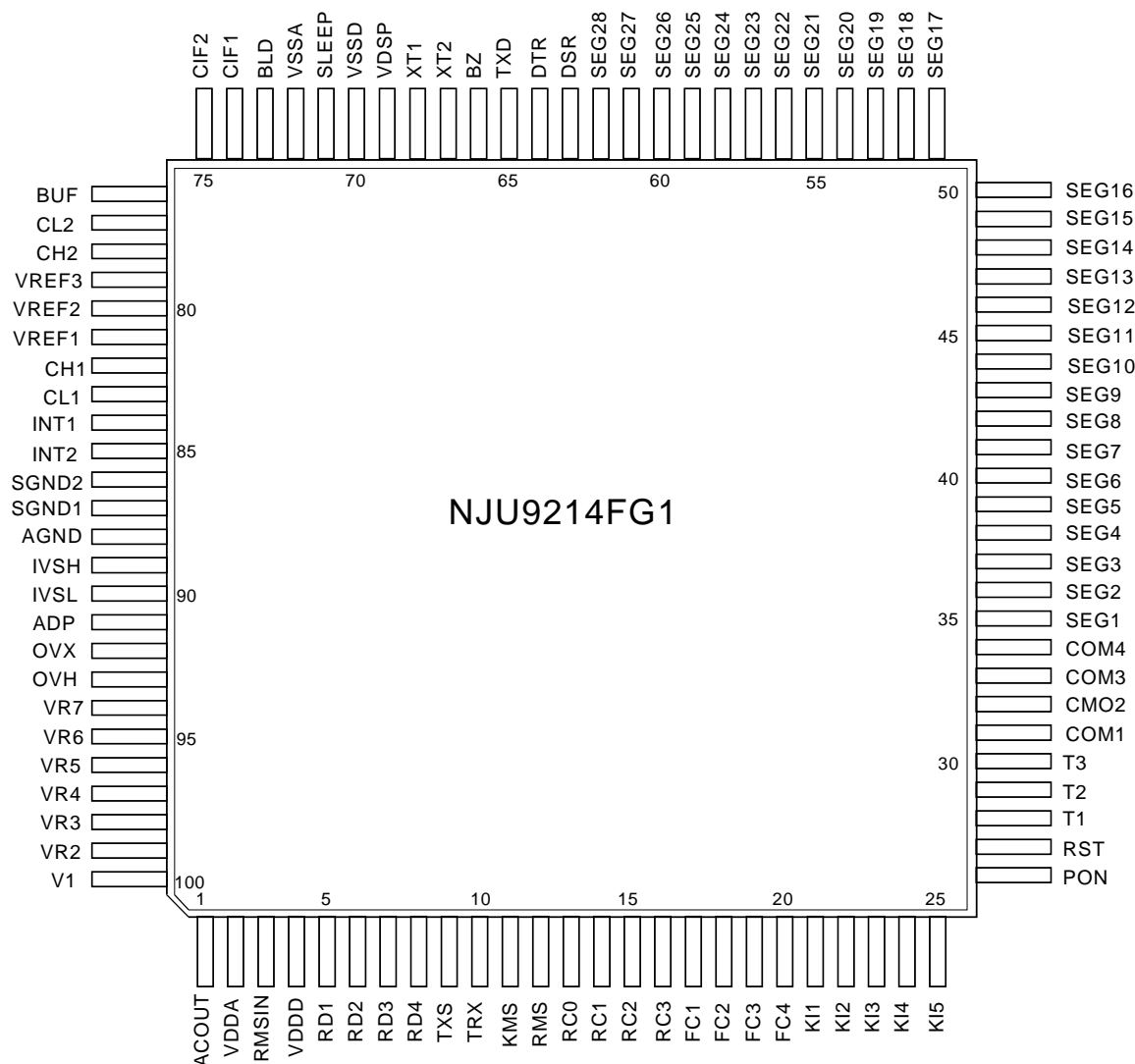

TERMINAL DESCRIPTION

No.	SYMBOL	I/O	FUNCTION
1	ACOUT	Out	Attenuator output terminal (used at ACA, ACmA, FRQ, rpm)
2	VDDA	-	Analog VDD (VDDA = 5.0 ± 0.25V)
3	RMSIN	In	RMS-Voltage Input Terminal
4	VDDD	-	Digital VDD (VDDD = 5.0 ± 0.25V)
5 to 8	RD1 to RD4	Out	Relay Driving Terminal
9	TXS	In	RS232C Output-Rate Select Terminal L ; 9600bps H ; 2400bps
10	TRX	In	RS232C Function Select Terminal
11	KMS	In	Key Mode Select Terminal
12	RMS	In	Range Control Mode Select Terminal
13 to 20	RC0 to RC3	In	Range Select Terminal with Input Pull-up Resistance (300kΩ)
17 to 20	FC1 to FC4	I/O	Function Select Terminal with Input Pull-up Resistance (300kΩ)
21 to 25	KI1 to KI5	In	Optional Function Control Terminal with Input Pull-up Resistance (300kΩ)

No.	SYMBOL	I/O	FUNCTION
26	PON	In	Auto Power-off Mode Release Terminal with Input Pull-up Resistance (300Ωk)
27	RST	In	System Reset Terminal with Input Pull-up Resistance(10kΩ)
28 to 30	T1 to T3	In	Test Terminal with Input Pull-up Resistance (300kΩ)
31 to 34	COM1 to COM4	Out	LCD Common Terminal
35 to 62	SEG1 to SEG28	Out	LCD Segment Terminal
63	DSR	In	RS232C Data Set Ready Terminal
64	DTR	Out	RS232C Data-Terminal Terminal
65	TXD	Out	RS232C Data Output Terminal
66	BZ	Out	Piezo Buzzer Driving Terminal
67	XT2	Out	Crystal oscillation Inverter (Output)
68	XT1	In	Crystal oscillation Inverter (Input)
69	VDSP	I/O	LCD driving voltage I/O Terminal Opened : $VDSP=(VDDD-VSSD) \times 3/5$ Connected to VSSD : $VDSP=(VDDD-VSSD)$
70	VSSD	-	Digital VSS VSSD=0V
71	SLEEP	Out	Auto Power-off signal Terminal (Power-off:"H" Level)
72	VSSA	-	Analog VSS VSSA=-5.0V
73	BLD	In	Buttery Life Detector Terminal, Detection: $BLD < 4.0V$
74,75	CIF2, CIF1	I/O	High-speed integration capacitor connecting Terminal
76	BUF	Out	High-speed integrator buffer output Terminal
77,78	CL2, CH2	I/O	High-speed integrator reference capacitor connecting Terminal
79 to 81	VREF3 to VREF1	In	VREF1:High-accurate integrator reference voltage input Terminal VREF2:High-speed integrator reference voltage input Terminal VREF3:Capacitance measurement integrator reference voltage input Terminal
82,83	CH1, CL1	I/O	High-accurate integrator Reference capacitor connecting Terminal CL1;"-",CH1;"+"
84,85	INT1, INT2	I/O	High-accurate integrator capacitor connecting Terminal
86,87	SGND2, SGND1	In	Analog sensing Terminal
88	AGND	-	Analog GND Terminal
89	IVSH	In	Current measurement (A) sensing Terminal
90	IVSL	In	Current measurement (mA) sensing Terminal
91	ADP	In	Adapter input Terminal
92	OVX	In	Sensing Terminal (Resistance,Continuity,Capacitance)
93	OVH	Out	Voltage supply Terminal (Resistance,Continuity,Diode,Capacitance)
94	VR7	I/O	Bleeder Resistance Terminal for 4V,40V range
95	VR6	I/O	Bleeder Resistance Terminal for 400Ω range
96	VR5	I/O	Bleeder Resistance Terminal for 4000V,4kΩ range
97	VR4	I/O	Bleeder Resistance Terminal for 400V,40kΩ range
98	VR3	I/O	Bleeder Resistance Terminal for 40V,400kΩ range
99	VR2	I/O	Bleeder Resistance Terminal for 4V,4000kΩ range
100	VI	In	Voltage input Terminal for 400mV range

FUNCTION DESCRIPTION

(1) Measurement function

Each measurement functions shown below is available with the **NJU9214**.

MEASUREMENT FUNCTION	RANGE	Auto/Manual	
DC/AC Voltage	400mV to 4000V	Auto:4-range/Manual:5-range	*1
DC/AC Current	4mA to 4000mA	Auto-Manual-2range/Manual-4range	*2
DC/AC Current	40A	Fixed	
Resistance (Ω)	400Ω to 40MΩ	Auto:6-range/Manual:6-range	
Frequency (f)	100Hz to 1000kHz	Auto:5-range	
Capacitance (C)	4nF to 400μF	Auto:6-range/Manual:6-range	
Tacho (rpm)	6000rpm to 600Krpm	Auto:3-range	
Diode(▶)		Fixed	
Continuity(🔊)		Fixed	
ADP		Fixed	*3

*1 400mV range (AC/DC) is selected in only manual range.

*2 4mA-4000mA range has Auto/Manual-2range and Manual-4range mode, each mode needs its own application circuit.

*3 ADP is applied for °C, hfe and other measurement.

(1 - 1) Voltage (DCV, ACV) measurements

The divided voltages which are output from each resistance R1 to R5 shown in following table are supplied to A/D converter.

In the AC measurement, after the dividing voltage, these output voltages are converted to DC Voltages with the external RMS/DC converter. This DC voltage is supplied into A/D converter.

10MΩ resistor for input terminal may be easy to be affected by noises.

Therefore 10MΩ and peripheral circuits require some protection like shields and so on for stable display.

The resistors for attenuating should be selected with a flat temperature characteristic. Especially, the resistors (10MΩ, 10kΩ, 1kΩ) for 400V, 4000V ranges should be selected carefully. For example, when 4,000V is input, 0.4mA (4,000V÷10MΩ) flow through 10MΩ, and the resistor consumes power of 1.6W (4,000V×0.4mA) and the temperature of the reference resistor.

After measuring at 400V, 4,000V ranges, sometimes the uncorrect value is shown on the display at 4V, 40V ranges because the value of resistor as the attenuator is changed by the temperature.

RANGE	DIVISION RATE
R1(400mV)	1
R2(4V)	1MΩ/10MΩ
R3(40V)	100kΩ /10MΩ
R4(400V)	10KΩ /10MΩ
R5(4000V)	1kΩ/10MΩ

(1 - 2) Resistance measurement(Ω)

As shown below, six type resistors (10M Ω ,1M Ω ,100k Ω ,10k Ω ,1k Ω ,100 Ω) connecting VR2 to VR7 are used for reference resistors of each range.

The output voltage on the measurement terminal is almost same as the voltage inputted Vref3.

As shown in Application circuits (1) to (3), an input protective diode must be connected with the OVH terminal. In resistance measurement, continuity test, diode check and capacitance mode, if the **NJU9214** is supplied high voltage on the OVH terminal from the external, the **NJU9214** may be broken completely.

In the R1 (400 Ω) range, sometimes the resistor value shows wrong display because of the influence by test leads and wiring resistances of a circuit board. In this case, it needs to adjust on the relative function using the 0 Ω resistance.

In the R6 (40M Ω) range, it may take a time to get the correct measurement value by the influence of parasitic capacitance and may not show the stable value by the noise effects.

RANGE	Refer.Resistance Value
R1(400 Ω)	100 Ω
R2(4K Ω)	1k Ω
R3(40K Ω)	10k Ω
R4(400K Ω)	100k Ω
R5(4000K Ω)	1M Ω
R6(40K Ω)	10M Ω

(1 - 3) Continuity test(\rightarrow)

The input attenuator is fixed to 400 Ω range of the resistance measurement mode. When the value is less than 40 Ω , the buzzer sounds. The output voltage on the measurement terminal is about 0.4V.

If the display doesn't show 0 Ω by resistances of lead wire when the terminals are shorted, this case requires adjustment at 0 Ω using the relative function.

(1 - 4) Diode check(\rightarrow)

The input attenuator is fixed to DC4V range. The output voltage on the OVH terminal is about 5V (VDDA), and it is supplied to the measurement terminal through the SW1 (external switch or relay).

(1 - 5) Current (DCmA, ACmA) measurement

Current measurement provides the Auto-Manual 2-range mode(RMS=H) and the Manual 4-range mode (RMS=L). These are changed by status of the RMS terminal. Each mode needs its own application circuit.

In the Auto-manual 2-range mode, the sense terminal is IVSL terminal at the 40mA range and IVSH terminal at the 400mA range.

In the Manual 4-range mode, the sense terminal is IVSL. In this mode, switching range is performed by changing the reference resistors. The SW for the reference resistor change must be operated together with the SWs connecting to ' RC1 to RC3 '. (Refer to (2 - 1 - 3))

(1 - 6) Current (DCA, ACA) measurement

It is fixed to the 40A range. The sense terminal is the IVSH terminal.

(1 - 7) Frequency (f) measurement

The input voltage is divided by the attenuator, and then the attenuator output is supplied to counter through the buffer.

The divided voltage is converted to DC voltage by the external RMS/DC converter, and the dividing voltage ratio of the input attenuator is changed by this DC voltage, Noises or distorted waveforms sometimes show different display against actual frequency.

The frequency range is always fixed to the Auto-range mode. It is able to switch from 100Hz to 1,000kHz and the measurement cycle is 1 time a second.

(1 - 8) RPM measurement

It is possible to measure numbers of revolution like as the revolutions of engine. The measurement is same way as the frequency measurement. The revolutions are calculated by the value of 60 times the frequency.

The revolution range is always selected one of 6,000 to 600krpm automatically.

The minimum input voltage (wave amplitude) is about 300mV and the measurement cycle is 1 time a second.

(1 - 9) Capacitance (C) measurement

The constant-current charges the measured capacitor, and the charging time, while the voltage of capacitance reaches to the reference voltage, is measured and converted to the capacitance value.

If the measured capacitor has any electric charges, accurate measurement is not available. Therefore the measured capacitor must be discharged before measurement.

The sense terminal is the OVX terminal.

(1 - 10) Adapter (ADP) measurement

The voltage between the ADP terminal and the SGND is supplied to the A/D converter directly. Both of ADP terminal (+) and SGND terminal (-) are High-impedance in DC400mV range.

Therefore, it is also used as differential input.

(2) Switch input Mode

The lock or push type input switch is applied for function selection. The switch type is selected in both of auto and manual ranges by the RMS terminal setting.

When the push type switch is selected, auto ranging is always selected.

When the lock type switch is selected and the RMS terminal is GND (L) level, all ranges are selected by switches. But if the RMS terminal is VDD level (H), auto range, manual range selection and the range set are performed by a push type switch.

KMS Terminal	RMS Terminal	SWITCH	RANGE
H	H	Lock type	Full Auto
H	L		Manual
L	*	Push type	Full Auto

* : Don't Care

Both of lock and push type application have the chattering protective function which reject the chattering less than 20ms.

(2 - 1) Lock type switch

(2 - 1 - 1) Measurement function selection (KMS = " H ")

The measurement function is set by FC1 to FC4 terminal. Excepting the following settings, all others select the DCV measurement mode.



Measurement mode	FC1	FC2	FC3	FC4
D C V	H	H	H	H
A C V	L	H	H	H
D C mA	H	L	H	H
A C mA	L	L	H	H
Resistance (Ω)	H	H	L	H
Continuity (🔊)	L	H	L	H
Diode (▶)	H	L	L	H
Capacitance (C)	L	L	L	H
D C A	H	H	H	L
A C A	L	H	H	L
Frequency (f)	H	L	H	L
r p m	L	L	H	L
A D P	H	H	L	L

(2 - 1 - 2) Range setting (Lock type & Auto-Ranging : KMS = RMS = " H ")

The range shown in below table is controlled by a switch of the RC0 terminal which must go to "L" level (GND) when it is pressed. When the switch is pressed once, the range is changed from Auto-range to manual-range, and its range is held. Then, the range is changed in every time by the switch operation. The range always returns to Auto-range from any kinds of range when the switch is pressed over than 1 second.

Measurement Mode				Ranging control	Default Range	
	Auto	Manual	Range up			
D C V	R ₂ to R ₅	→ H O L D	(R ₅ →R ₂)	4V to 4000V	4V	
A C V	R ₂ to R ₅		(R ₅ →R ₂)	4V to 4000V	4V	
D C mA	R ₂ to R ₃		R _i → R _{i+1} (R ₃ →R ₂)	40mA to 400mA	40mA	
A C mA	R ₂ to R ₃		(R ₃ →R ₂)	40mA to 400mA	40mA	
Resistance (Ω)	R ₁ to R ₆		(R ₆ →R ₁)	400Ω to 40MΩ	400Ω	
Continuity (🔊)	F I X E D				400Ω	
Diode (▶)						4V
A D P						400mV
D C A						40A
A C A						40A
Frequency (f)	R ₁ to R ₅		Auto-range	100Hz to 999.9kHz	100Hz	
Tacho (r p m)	R ₁ to R ₃			6000rpm to 600krpm	6000rpm	
Capacitance (C)	R ₁ to R ₆	→H O L D	R _i →R _{i+1} (R ₆ →R ₁)	4nF to 400uF	4nF	

(Note) Frequency measurement and revolution measurement are always set to the Auto-Range.

Ranges of continuity test (), diode check (), ADP, DCA and ACA measurement are always fixed to the default ranges. Just after the power-on operation or mode changing, the range is set to the default range.

In the ADP measurement, three units are displayed by setting of RC1 to RC3 terminals.

The R1 to R6 of above range control table are set as a range corresponding to below table.

RANGE	D C V	A C V	D C mA	A C mA	Ω	f	r p m	C
R ₁	400mV	400mA	—	—	*400 Ω	*100Hz	*6000	*4nF
R ₂	*4V	*4V	*40mA	*40mA	4k Ω	1000Hz	60000	40nF
R ₃	40V	40V	400mA	400mA	40k Ω	10kHz	600k	400nF
R ₄	400V	400V	—	—	400k Ω	100kHz	—	4uF
R ₅	4000V	4000V	—	—	4000k Ω	1000kHz	—	40uF
R ₆	—	—	—	—	40M Ω	—	—	400uF

(NOTE) The " * " mark means the default range.

Changing to DC400mA range or AC400mA is available by only manual operation. Auto-range operation cannot change to these ranges.

(2 - 1 - 3) Range setting (Lock type switch & Manual-range : KMS = " H ", RMS = " L ")

The range setting shown in below table is available with RC1 to RC3 terminal.

RC1	RC2	RC3	DCV, ACV	DCmA, ACmA	Ω	C
H	H	H	400mA	4mA	400 Ω	4nF
L	H	H	4V	40mA	4k Ω	40nF
H	L	H	40V	400mA	40k Ω	400nF
L	L	H	400V	4000mA	400k Ω	4uF
H	H	L	4000V	4mA	4000k Ω	40uF
L	H	L	400mV	4mA	40M Ω	400uF
H	L	L	400mV	4mA	400 Ω	4nF
L	L	L	400mV	4mA	400 Ω	4nF

(NOTE) Frequency and revolution measurements are always set to the Auto-range.

Ranges of continuity test (), diode check (), ADP, DCA and ACA measurement are always fixed to the default ranges.

(2 - 2) Push type switch

(2 - 2 - 1) Measurement function selection (KMS = " L ", ARMS = " X ")

Measurement function is set to the mode depending on the below matrix table;

		Control Terminals				
		KI1	KI2	KI3	KI4	KI5
Selection Terminals	FC1	Don't care	HOLD	MIN/MAX	MEN	READ
	FC2	Don't care	FRQ	ADP	REL	CAP
	FC3	Don't care	DC/AC			Ω
	FC4	rpm	V	mA	A	RANGE

All switches excepting for the power switch should be used non-locked push type switch.

The range is set to the full auto-range mode and selected by the "RANGE" key.

When the power is turned on, the mode is set to the DCV. When the auto power-off is released, the mode returns to the previous mode of auto power-off.

The functions of HOLD, MIN/MAX, MEM, READ and REL are same as KI1 to KI5 input using lock type switch which is explained in (4) Attached functions.

If some of switches are pressed at the same time, the input order is as follows,

Selection terminal : FC4→FC3→FC2→FC1

Control terminal : KI5 → KI4 → KI3 → KI2 → KI1

< Example of the switch circuit >

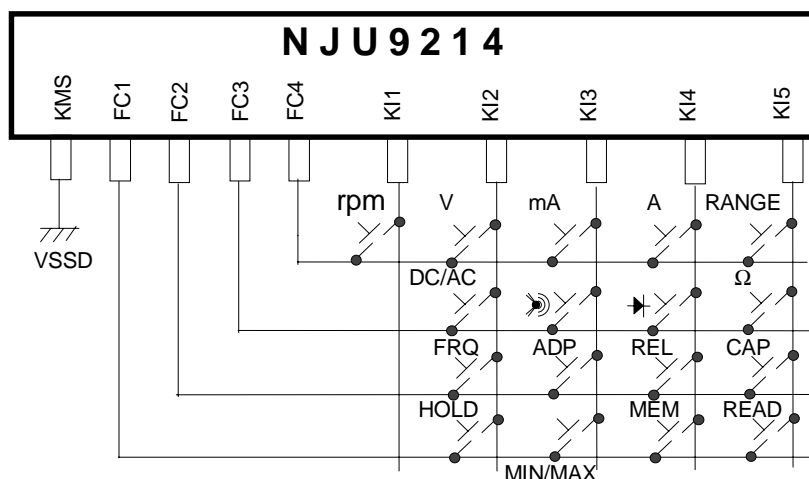



Range setting (Push type switch : KMS = " L ", RMS = " X ")



The range setting shown in below table is available with the " RANGE " switch.

When the switch is pressed once, the range is changed from auto to manual, and it's range is held.

Then, the range is changed in everytime by the switch operation. When the switch is pressed over than 1 second, the range always returns to Auto-range is possible from any range statuses.

Measurement Mode	1push(>1sec)			Ranging Control	Default Range
	Auto	Manual	Range up		
D C V	R ₁ to R ₅	→ HOLD	(R ₅ →R ₁)	400mV to 4000V	4V
D C V	R ₁ to R ₅		(R ₅ →R ₁)	400mV to 4000V	4V
D C mA	R ₂ to R ₃		R _i →R _{i+1} (R ₃ →R ₂)	40mA to 400mA	40mA
D C mA	R ₂ to R ₃		(R ₃ →R ₂)	40mA to 400mA	40mA
Resistance (Ω)	R ₁ to R ₆		(R ₆ →R ₁)	400Ω to 40MΩ	400Ω
Continuity ()	F I X E D				400Ω
Diode ()					4V
A D P					400mV
D C A					40A
A C A					40A
Frequency (f)	R ₁ to R ₅		Auto-range	100Hz to 999.9kHz	100Hz
Tacho (r p m)	R ₁ to R ₃			6000rpm to 600krpm	6000rpm
Capacitance (C)	R ₁ to R ₆	→ HOLD	R _i →R _{i+1} (R ₆ →R ₁)	4nF to 400uF	4nF

(NOTE) Frequency measurement and Tacho are always set to the auto-range.

Ranges of continuity test (), diode check (), ADP, DCA and ACA measurements are always fixed to their default ranges.

Just after power-on operation or changing mode, their ranges are set to the default range.

In the ADP measurement, 3 units are displayed by setting of RC1 to RC3 terminals.

The R₁ to R₆ of above range control table are set a range corresponding to below table.

RANGE	DCV	ACV	DCmA	ACmA	Ω	f	r p m	C
R ₁	400mV	400mA	-	-	*400Ω	*100Hz	*6000	*4nF
R ₂	*4V	*4V	*40mA	*40mA	4kΩ	1000Hz	60000	40nF
R ₃	40V	40V	400mA	400mA	40kΩ	10kHz	600k	400nF
R ₄	400V	400V	-	-	400kΩ	100kHz	-	4uF
R ₅	4000V	4000V	-	-	4000kΩ	1000kHz	-	40uF
R ₆	-	-	-	-	40MΩ	-	-	400uF

(NOTE) The " * " mark means the default range.

Changing to DC400mV range or AC400mV range is available by only manual operation. Auto-range operation cannot change to these ranges.

When the auto-range is switched in DC400mV or AC400mV range, measurement is continued in the 400mV range. When overflow occurs in 400mV of the auto-range, its range changes to 4V range automatically.

< Example of the Latching Relay Driver Circuit >
 RD1 to RD4 are normally " H ". (Active " L ")

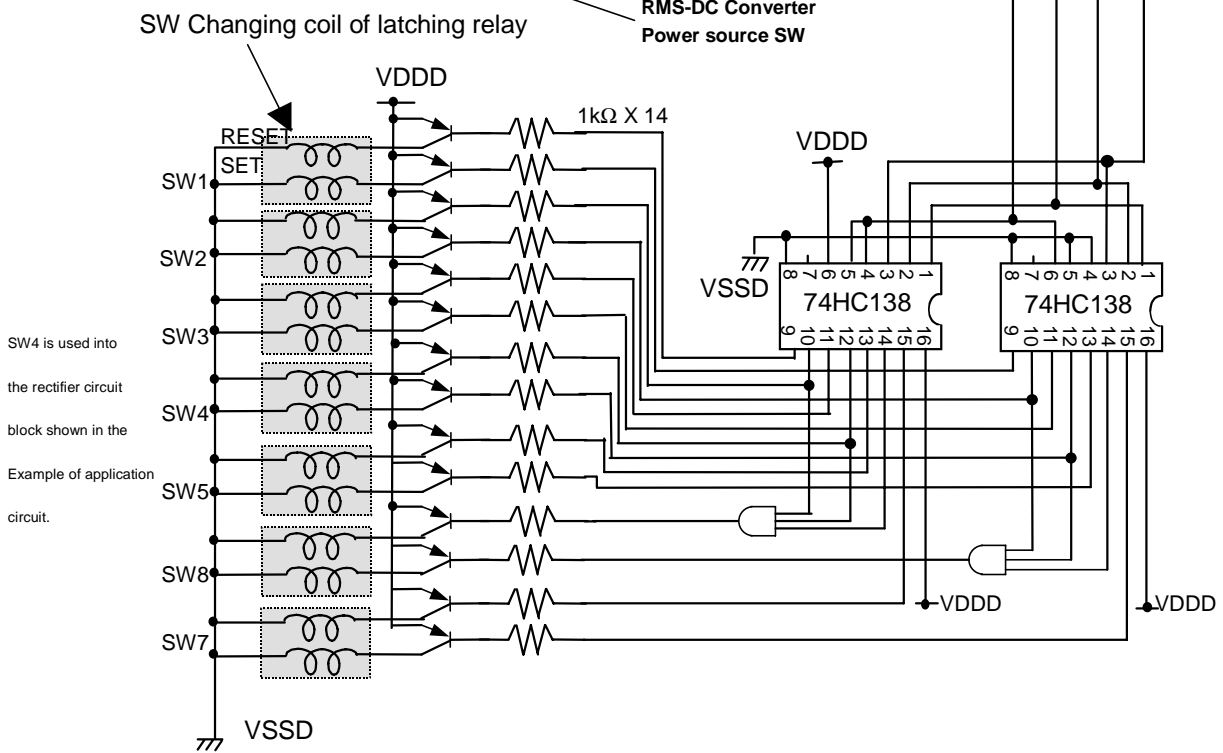
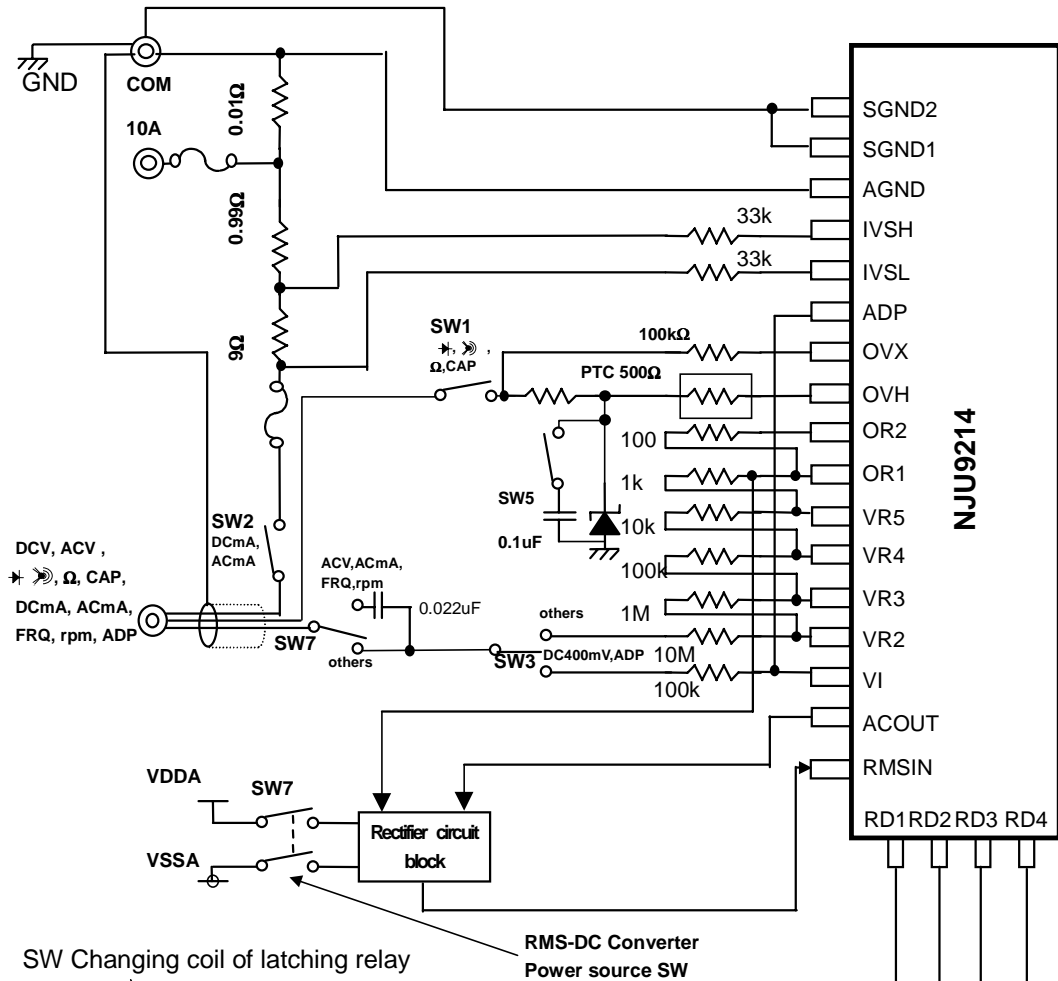

About 10ms pulse width signal shown in below table is outputted from RD1 to RD4. This pulse controls the Latching Relay Driving.

FUNCTION RANGE		Relay		RD1	RD2	RD3	RD4
Ω , mA , V , AP DCmA, ACmA DC400mV, ADP AC400mV Ω , V ACA ACmA,ACA,ACV,FRQ,rpm	Set	SW1	Set				
		SW2					
		SW3					
		SW4					
		SW5					
		SW6					
		SW7					
Ω , mA , V , CAP DCmA, ADP DC400mA, ADP AC400mV Ω , V ACA ACmA,ACA,ACV,FRQ,rpm	Reset	SW1	Reset				
		SW2					
		SW3					
		SW4					
		SW5					
		SW6					
		SW7					

(4) Attached functions (Functions with KI1 to KI5 are available by only lock type switches.)

(4 - 1) Data Hold : HOLD

The hold or release of all display data is performed alternately by KI1 terminal input.

However, A/D conversion is operating even though in the HOLD status, therefore the buzzer sounds at the over-range and the continuity test.

In the auto-range operation, changing of range is available.

(4 - 2) Relative Measurement : FREL

The relative measurement is selected when the switch connecting to KI2 terminal is pressed. In this mode, the value of difference between the present and the just before value is displayed.

In case of the auto-range, the range is held at the just before range.

However, the bargraph displays the absolute value, not the relative value.

And the over-range also occurs from the absolute value of input. When the KI2 is pressed over than 1 second, the relative mode is released.

(4 - 3) Min. / Max. Hold : MIN/MAX

When the switch connecting to terminal KI3 is pressed, the mode is circulated as follows ;

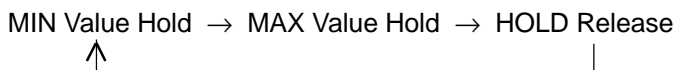

The bargraph always displays the input value.

(4 - 4) Data Memory : MEN

When the switch connecting to terminal KI4 is pressed, all of display data is stored into the memory.

The stored data can be read out and displayed on LCD by pressing the READ key connecting to terminal KI5, and [MEM] mark blinks during this mode.

This mode is released by pressing the READ key connecting to terminal KI5.

(4 - 5) Buzzer output

2kHz buzzer sounds at following cases ;

- [1] Key operation (except function changing and range changing)
- [2] Auto-power off operation
- [3] Continuity test () ; less than 40Ω
- [4] Releasing from relative mode and MIN / MAX display
- [5] Changed between manual-range and auto-range by RCO terminal
- [6] Auto-range: Overflowing at 4,000V range
Manual-range: Overflowing at every range except 400mV range
- [7] Power-on operating and Releasing from the Auto-power off mode
- [8] Twice sounds from 24 seconds before and every 8 seconds

(4 - 6) Low-Battery Detector : BLD

If the supply voltage is less than $4.0 \pm 0.4V$, [BATT] mark is blinked.

(4 - 7) Auto power-off

If the key-operation doesn't work over than 30 minutes, the power is turned off automatically after 1 second buzzer sound, and all display is disappeared. (the data in the memory is kept)

When the PON terminal is pressed or power switch is turned off, this mode is released.

In case of release by PON terminal, the previous value of the auto power-off operation is displayed for 2 seconds. To void this function, the power should be turned on with pressing the switch connecting to the PON terminal.

The **NJU9214** gets some voltage surges during the power off mode by the auto power off operation, it might not return to usual operation correctly.

(4 - 8) Setting the mode at Power-on, Function and Range changing

FUNCTIONS	Power-on	Function changing	Range changing
Range(Auto range)	Default range	Default range	-
Range Hold	Reset	Reset	Hold
Data Hold			Reset
Relative Measure MIN / MAX Hold			Reset
Data Memory	All " 0 " display	Hold	Hold
Auto power-off	Auto off	Auto off	Auto off

(4 - 9) Display of ADP setting

In measurement operation by the ADP function, the following display setting by RC1 to RC3 terminals is available.

RC1	RC2	RC3	Mark Display	Decimal Point	Application Example
H	H	H	Non	Non	hfe Measurement
L	H	H	ADP1	P1	°C (Temp. Measurement)
H	L	H	ADP2	P1	°F (Temp. Measurement)
L	L	H	*	*	*
H	H	L	*	*	*
L	H	L	*	*	*
H	L	L	*	*	*
L	L	L	*	*	*

* : (Don't Care)

(5) Serial Data output

The **NJU9214** has terminals (TXD,DTR,DSR) for serial data output with RS-232C format requiring a external RS-232C I/F LSI.

When the TRX terminal is " L " level, data transmission is available, and when DSR terminal is also " L " level, the data starts to output.

It selects the transmission rate by the TXS terminal, "L" level : 9,600bps,
"H" level : 2,400bps.

The logic levels from all of output terminals are " L " $\leq 0.8V$, " H " $\leq 4.2V$.

(5 - 1) The structure of the serial data

An unit of serial data consists of 10bits. The first bit of data is Start bit, the 2nd to the 9th bits are Data bits, the 10th is Stop bits, therefore 11bits data structures a character as an unit.

The data is transmitted from the LSB in sequence. Regarding the data order, please refer to [(5 - 3) RS-232C Data Format].

The data is outputted with the ASCII code.

(5 - 2) Example of transmission waveform

Example of transmission waveform on the TXD terminal is shown below.

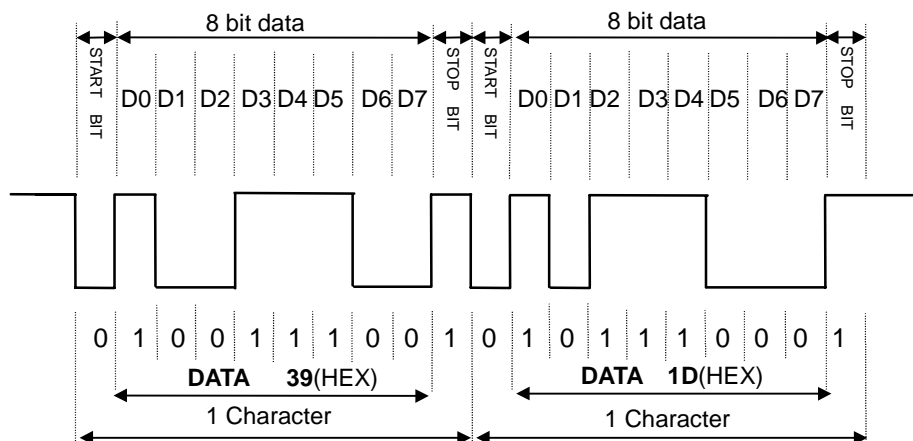

(5 - 3) RS-232C Data format

As shown below table, the data transmitted through the RS-232C is structured with 1 frame consisting of 17 characters.

(Example) DCV measurement value = 100mV

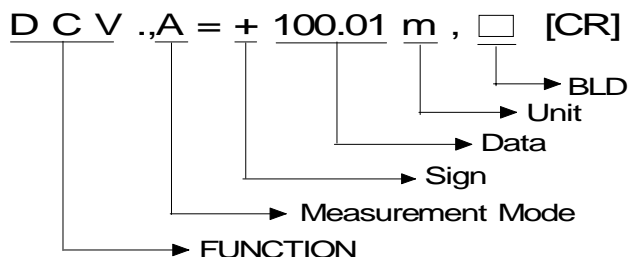

(5 - 3 - 1) Function

FUNCTION	CHARACTER
DCV	D C V
ACV	A C V
DCA	D C A
ACA	A C A
RESISTANCE	O H M
Continuity	C H K
Diode	D I O
Capacitance	C A P
Frequency	F R Q
Tacho	r p m
ADP	A D P

(5 - 3 - 2) Measurement Mode

Measurement Mode	Character
Absolute Value	A
Relative Value	R

(5 - 3 - 3) Sign

This sign shows the polarity of data.

Sign	Character
Positive Number	+ (PLUS)
Negative Number	- (MINUS)

(5 - 3 - 4) DATA

The data consists of six figures including a decimal point.

(5 - 3 - 5) Unit

This unit name shows the following characters.

Unit Name	Character
Mega-	M
Kilo-	K
-	<input type="checkbox"/> (Space)
Milli-	m
Micro-	μ
Nano-	n

(5 - 3 - 6) Buttery Life Detector

It shows the condition of buttery.

Condition	Character
Normal	<input type="checkbox"/> (Space)
Low-Buttery warning	B

(5 - 3 - 7) Examples of various data

[Ex.1] In DCV400mV range, when following voltage is measured.

Measured value 100.01mV

Format Pattern

DCV, A=+100.01m, [CR]

The actual data from RS-232C line is shown below.

ASCII CODE	D	C	V	,	□	[CR]
HEX CODE	&H44	&H43	&H52	&H2C	...	
RS-232C DATA	00010001011	01100001011	00100101011	00011010011		
...	0	1	m	,	<input type="checkbox"/>	[CR]
	&H30	&H31	&H6D	&H2C	&H20	&H0D
	00000110011	0100011011	01011011011	00011010011	00000010011	01011000011

[Ex.2] On the condition of Ex.1, when relative mode is used.

To calculate the relative value, the reference voltage must be required. The reference voltage is the measured voltage of relative mode.

Example of the reference voltage = 100.00mV.

measured value 100.01mV

relative value 100.01mV - 100.00mV = 0.01mV

Format pattern

DCV, R=+000.01m, [CR]

[Ex.3] In DCV400mV range, when overflow is occurred on the positive voltage side by 401mV input.

Measured value overflow on the "+" side

Format pattern

DCV, A=+***.**m, [CR]
 "***.**" shows overflow, "+" shows overflow on the positive side.

[Ex.4] In DCV400mV range, when overflow is occurred on the negative voltage side by -401mV input.

Measured value overflow on the "-" side

Format pattern

DCV, A=-***.**m, [CR]
 "***.**" shows overflow, "-" shows overflow on the negative side.

[Ex.5] In DCV400mV range, when the battery life detector warns under the condition of Ex.1.

Measured value 100.01mV

Format pattern

DCV, A=+100.01m, B[CR] ← Battery life detector

[Ex.6] In ACA400mA range, when the following current is measured.

Measured value 40.00mA

Format pattern

ACA, A=+040.00m, [CR]

[Ex.7] In resistance 400kΩ range, when the following resistance is measured.

Measured value 100.10kΩ

Format pattern

OHM, A=+100.10k, [CR]

[Ex.8] In frequency 10kHz range, when the following frequency is measured.

Measured value 5.35kHz

Format pattern

FRQ, A=+005.35k, [CR]

[Ex.9] In tachometer 6000rpm range, the following revolution is measured.

Measured value 2500rpm

Format pattern

rpm, A=+02500 , [CR]

(6) Reference voltage

The resolution of **NJU9214** is 25ppm (1/40000), and high precision is required for the reference power supply. The reference voltage requires a high precision and a temperature compensated type like as a band-gap reference.

Reference voltages, VREF1 and VREF2 are about 0.2V, and VREF3 is about 2V.

(7) Example of Display Layout

(7-1) Connection of Common Line

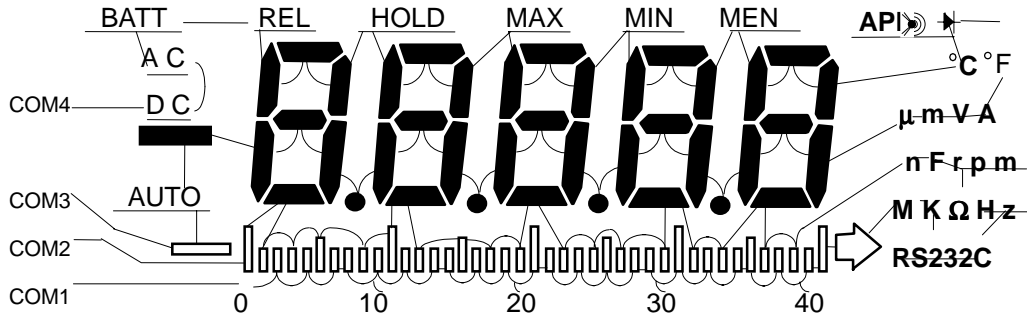

(7-2) Connection of Segment Line

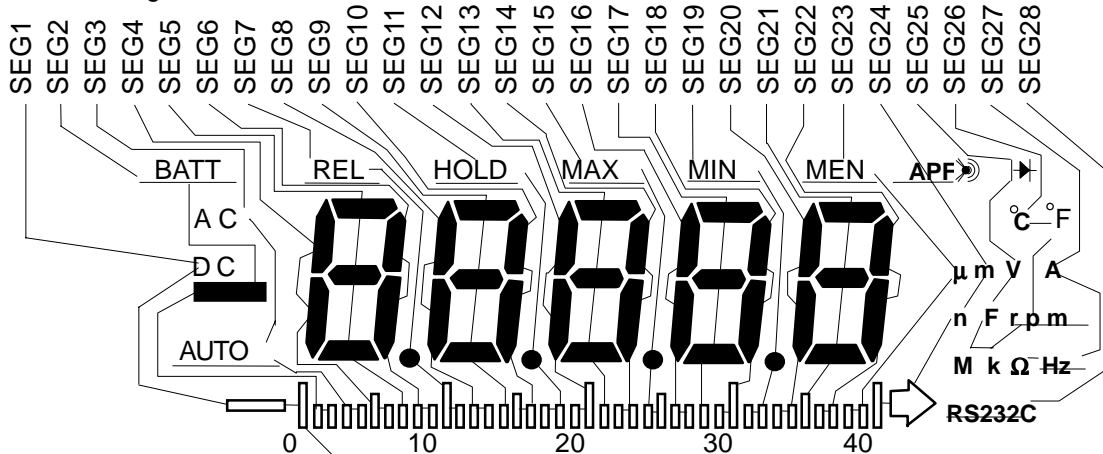

(7-3) Segment Assignment

	SEG1	SEG2	SEG3	SEG4	SEG5	SEG6	SEG7	SEG8	SEG9	SEG10
COM1	BP1	BP2	BP4	BP6	BP7	BP9	PB11	PB13	BP14	BP16
COM2	BP0	BP1	BP3	BP5	d4	BP8	BP10	BP12	d3	BP15
COM3	BP-	-	AUTO	e4	g4	c4	P4	e3	g3	c3
COM4	DC	BATT	AC	f4	a4	b4	REL	f3	a3	b3
	SEG11	SEG12	SEG13	SEG14	SEG15	SEG16	SEG17	SEG18	SEG19	SEG20
COM1	BP18	BP20	BP21	BP23	BP25	BP27	BP28	BP30	BP32	BP34
COM2	BP17	BP19	d2	BP22	BP24	BP26	d1	BP29	BP31	BP33
COM3	P3	e2	g2	c2	P2	e1	g1	c1	P1	e0
COM4	HOLD	f2	a2	b2	MAX	f1	a1	b1	MIN	f0
	SEG21	SEG22	SEG23	SEG24	SEG25	SEG26	SEG27	SEG28	/	/
COM1	BP35	BP37	BP39	BP40	M	k	Hz	RS232C	/	/
COM2	d0	BP36	BP38	n	F	rpm	Ω	/	/	/
COM3	g0	c0	μ	m	V	°F	A	/	/	/
COM4	a0	b0	MEM	APF	↻	°C	↗	/	/	/

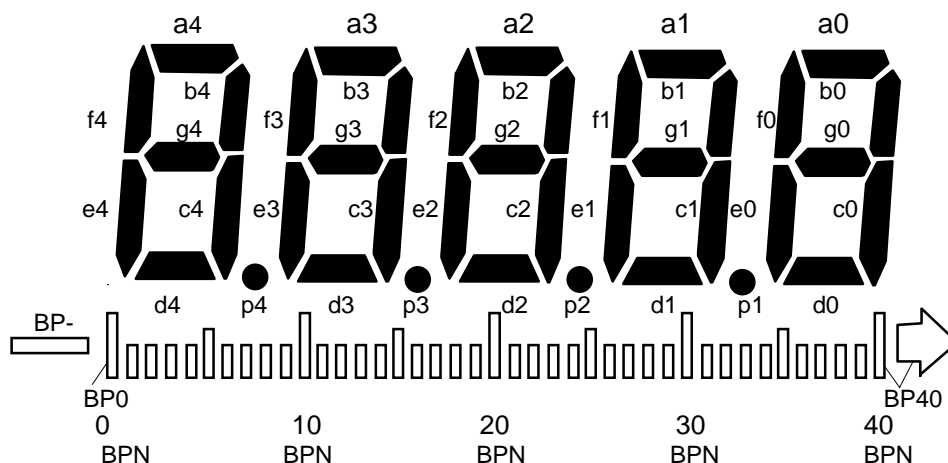

(7 - 4) Explanation of Display Mark

1. BATT : Low-Battery Detecting mark.
2. DC : Displayed in DC voltage and DC current measurement mode.
3. AC : Displayed in AC voltage and DC current measurement mode.
4. - : Displayed in DC voltage and DC current measurement negative input.
This mark doesn't display in AC voltage, AC current, resistance(Ω), frequency (f), diode (\rightarrow), and capacitance (C) and continuity (\rightarrow) measurement mode.
5. AUTO : Displayed in the auto range measurement mode.
6. REL : Displayed in the relative display measurement mode.
7. HOLD : Data Hold. Displayed in Memory READ with READ key.
8. MAX : Displayed in maximum display mode.
9. MIN : Displayed in minimum display mode.
10. MEM : Displayed during memorizing data. Blinked during recalling the data.
11. \rightarrow : Displayed in continuity test measurement mode.
12. \rightarrow : Displayed in diode check measurement mode.
13. mV : Displayed in DCmV and ACmV ranges.
14. mA : Displayed in DCmA and ACmA ranges.
15. $^{\circ}\text{C}$: In ADP measurement mode, displayed with ADP1 mark.
16. $^{\circ}\text{F}$: In ADP measurement mode, displayed with ADP2 mark.
17. nF : Displayed in capacitance measurement mode. (4nF, 40nF, 400nF ranges)
18. μF : Displayed in capacitance measurement mode.(4 μF , 40 μF , 400 μF ranges)
19. Ω : Displayed in resistance measurement mode.(400 Ω range)
20. k Ω : Displayed in resistance measurement mode.(k Ω range)
21. M Ω : Displayed in resistance measurement mode.(M Ω range)
22. Hz : Displayed in frequency measurement mode.(Hz range)
23. kHz : Displayed in frequency measurement mode.(kHz range)
24. rpm : Displayed in tachometer measurement mode.
25. RS-232C : Displayed in available mode of RS-232C Blinking under RS-232C operation.
26. APF : Displayed under Auto Power Off operation. After 30 minutes from the last key input, the power is turned off automatically.

(7 - 5) Bargraph display

The bargraph displays 10 times speed comparing with numeric display. However it is not displayed in frequency, revolution and capacitance measurement mode.

1. BP- : Displayed when negative signal is input.
2. BP0 : Displayed when the digital display is more than about "00400".
3. BP1 to 40 : BP1 is displayed when the digital display is more than about "01000", then 1 segment display increases at every 1,000 counts.
If overflow occurs, all of BP0 to BP40 are displayed.
4. The figures of " 0, 10, 20, 30, 40 " under the bargraph is displayed expecting for frequency, tacho and capacitance measurement mode.

(7 - 6) Over-range Display

When the over-range is occurred, the display becomes " 40000 " and all digit blinks.
However " 0000 " is displayed in frequency measurement mode, " 60000 " is displayed in revolution measurement mode, " 4000 " is displayed in capacitance measurement mode, and also every digit blinks in these modes.
In relative measurement mode, but it is not concerned with the display value. All of digits blink when over-range occurs by the absolute input value.

(7 - 7) Polarity Display

In cases of the " 0 " display value, AC voltage, AC current, resistance (Ω), diode (\blacktriangle), capacitance (C), frequency (f), tacho (rpm) and continuity test (⦿) measurement mode, " - " mark is not displayed. However in relative measurement mode, any measurement modes display " - " .

ABSOLUTE MAXIMUM RATINGS

(Ta=25°C)

PARAMETER		SYMBOL	RATINGS	UNIT
Supply Voltage Range		VDDA - VSSA	11	V
		VDDD - VSSD	5.5	V
Control Terminal Voltage		Vid	VDDD to VSSD	V
Analog Terminal Voltage		Via	VDDA to VSSA	V
Terminals Current	Supply Terminal	IDD, IGND, ISS	50	mA
	OVH Terminal	IOVH	50	
	Others	II	10	
Operating Temperature		Topr	0 to +50	°C
Storage Temperature Range		Tstg	-40 to +125	°C

VDDD and VDDA must be same voltage level.

ELECTRICAL CHARACTERISTICS

(1) DC Characteristics

(VDD = + 5.0V, VSSA = - 5.0V, AGND = DGND = 0V, DC400mV range, Ta=25°C)

PARAMETER		SYMBOL	CONDITIONS	MIN	TYP	MAX	UNIT	NOTE
Operating Voltage		VDD		4.75	5.0	5.25	V	1
Operating Current		IDD	VDD Terminal	-	-	1.5	mA	
		IPOF	VDD Terminal, in auto Power off	-	-	0.01	mA	2
Negative Supply Voltage		VSS	VDD Terminal	-4.75	-5.0	-5.25	V	
Low-Battery Detection Voltage		VBLD	VBLD terminal	3.6	4.0	4.4	V	
Linearity	Digital Display	Linn	Input Series Resistor = 100k Ω	-	-	±0.07+2	%FS±COUNT	
	Bargraph	Ling		-	-	±5	%FS	
Polarity Error	Digital Display	Epn		-	-	±0.07+2	%FS±COUNT	
	Bargraph	Epg		-	-	±5	%FS	
Zero Reading Display		Zero		0	0	0	COUNT	
Sampling Time	Digital Display	tsn		-	100	-	ms	
	Capacitance M.	tsnc	-	500	-			
	Bargraph	tsg	-	5	-			
Sampling Rate	Digital Display	Nrn	-	2	-	cyc./s		
	Capacitance M.	Nrnc	-	1	-			
	Bargraph	Nrg	-	20	-			
High Level Input Voltage		VIH	TXS, TRX, FC1 to 4, RC0 to 3, KI1 to 5, T1 to 3,	4.2	-	-	V	
Low Level Input Voltage		VIL	PON, KMS, RMS, RST Terminal	-	-	0.8	V	
Input Pull-Up Resistance		RI	TXS, TRX, FC1 to 4, RC0 to 3, KI1 to 5, T1 to 3, PON Terminal	100	300	500	kΩ	
			RST Terminal	-	10	-		

NOTE 1 : VDD is the general term for VDDA and VDDD.

NOTE 2 : In this case, all of key input levels are High.

In case of "LOW" level input into the key, 16uA current flow from a pin through an internal pull up resistance (300kΩTYP.) in TXS, TRX, KMS, RMS, RC 0 to 3, FC1 to 4, KI1 to 5, PON, T 1 to 3 terminals and 500uA current flow from RST terminal though a pull up resistance (10kΩ TYP.).

DC Characteristic (A/D conversion)

(VDD = +5.0V, VSSA = -5.0V, AGND = DGND = 0V, DC 400mV range, Ta = 25°C)

PARAMETER	SYMBOL	CONDITIONS		MIN	TYP	MAX	UNIT	NOTE
Buzzer Driving Current	IOH1	BZ Terminal	VOH = 4.7V	0.25	0.75	-	mA	
	IOL1		VOL = 0.3V	-0.25	-0.75	-		
Digital Output Current	IOH2	DTR, TXD Terminal	VOH = 4.6V	0.5	1.0	-		
	IOL2	RD1 to 4 Terminal	VOH = 0.4V	-0.5	-1.0	-		
Select Terminal Output Current	IOH3	FC1 to 4 Terminal (Push Switch Mode)	VOH = 4.6V	0.5	1.0	-		
	IOL3		VOH = 0.4V	-0.5	-1.0	-		
Open voltage in Resistance Measurement	VOHM	used for Ω, measurement		-	0.4	-	V	
Charging Voltage in Capacitance Measurement	VCAP	used for " C " measurement		-	5	-		
Input Leakage Current	ILO	VI Terminal	VIN=0mV	-	-	±10	pA	
	ILF		VIN=±400mV	-	-	±40		
LCD Driving Voltage (VDSP is floating.)	VH	SEG1 to 28, COM1 to 4 Terminal (vs VDDD Voltage)	-0.9	-1.0	-1.2	V	4	
	VL		-1.8	-2.0	-2.2			
LCD Driving Voltage (VDSP and VSSD are shorted.)	VH		-1.4	-1.6	-1.8			
	VL		-3.1	-3.3	-3.5			

NOTE 3 : The current source outputs VDD = 5V as an open voltage, however in normal operation, about 1V as the threshold of comparator is maximum voltage.

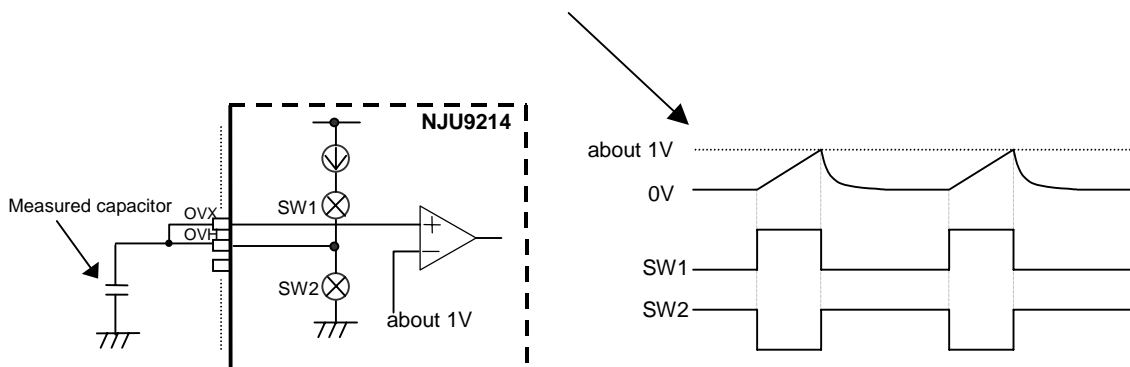

NOTE4 : LCD Diving Voltage (Example of output waveform)
 Waveform of 1/4 Duty, DC400mV range, VIN = 0mV

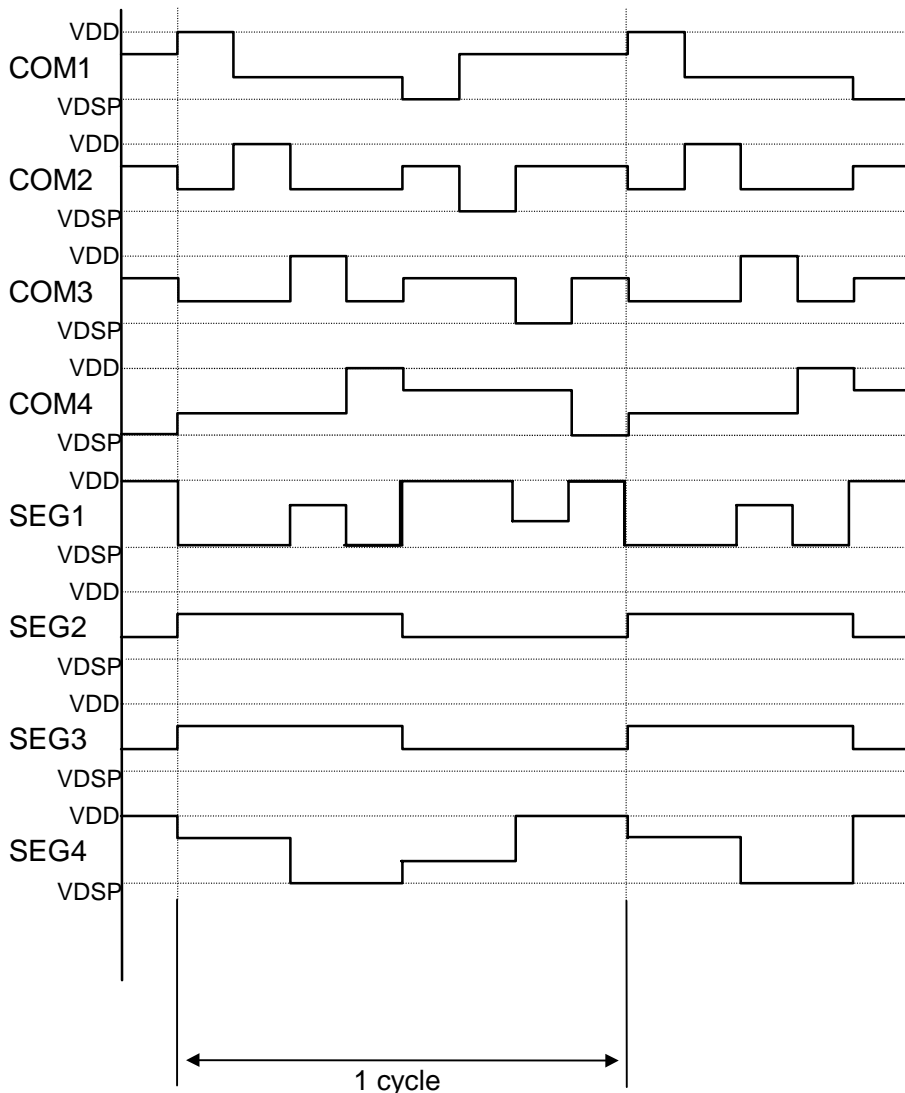

NOTE5 : Terminals of digital line are protected by the ESD protection circuit, however terminals of analog line aren't protected enough because the parasitic capacitance must be decreased. Therefore, if the **NJU9214** is given static electricity, it may be permanent breakdown. Therefore enough external surge protection is needed for assembling, carrying and keeping.

(2) Switching characteristic

(VDDA = VDDD = +5.0V, VSSA = -5.0V, AGND = DGND = 0V, DC4V range, fXT=4MHz, 25°C)

PARAMETER	SYMBOL	CONDITIONS	MIN	TYP	MAX	UNIT	
Buzzer Output Frequency	FBZ	BZ Terminal	-	2.0	-	kHz	
Data transmission rate	tOUT	TXD terminal	(TXS:H)	-	2400	-	bps
			(TXS:L)	-	9600	-	
LCD driver frequency	FLCD	SEG1 to 28, COM1 to 4 terminal	-	50	-	Hz	
Relay driver pulse width	twrd	RD1 to 4 terminal	-	10	-	ms	

Examples of application circuit.

(1) Circuit using lock type switch. (Current Auto • Manual-2 range mode, RMS = " H ")

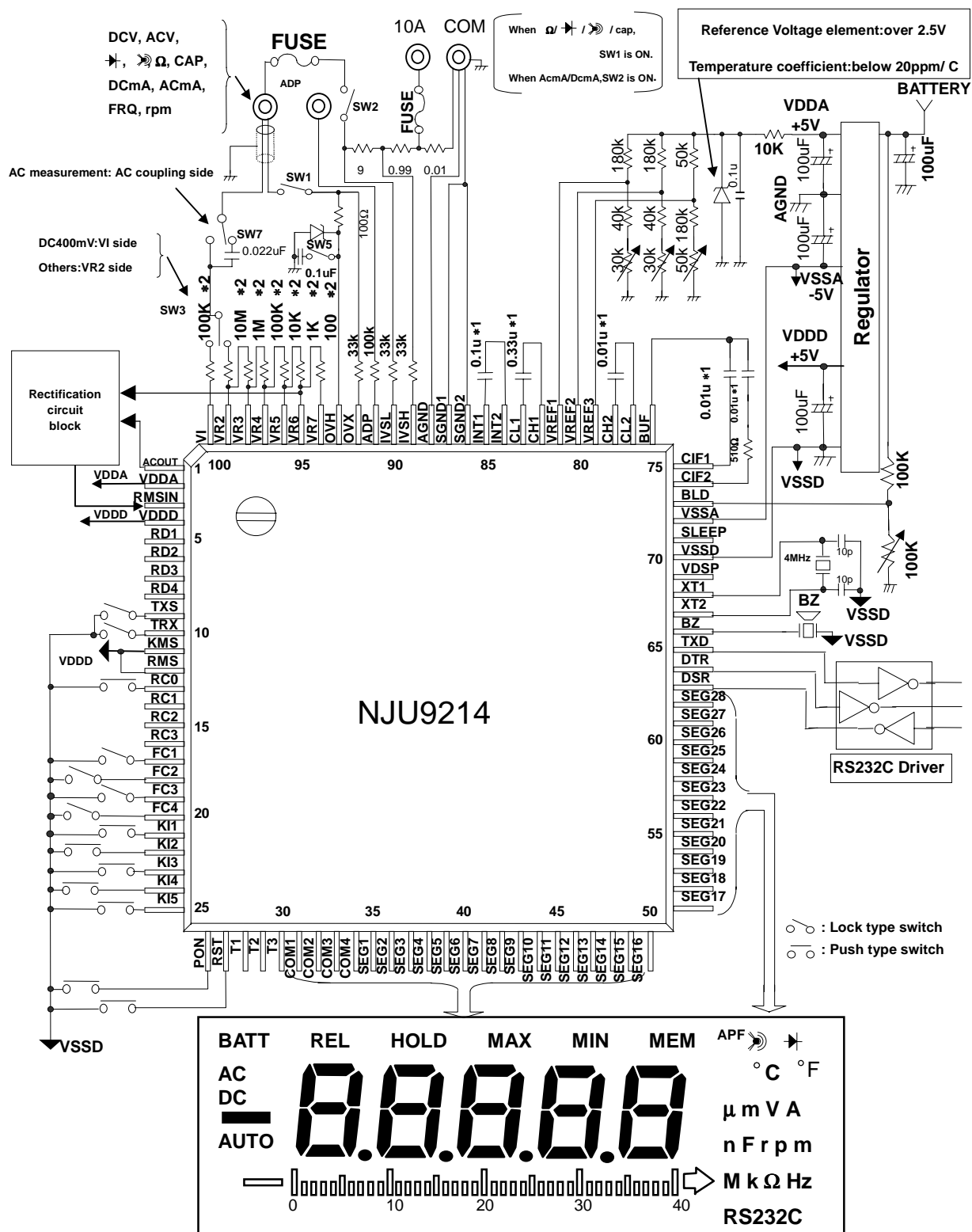

*1 Low-leak capacitors like as the polypropylene film type are required for accurate measurement.

*2 Within 0.01% tolerance resistors or the adjustment by the trimmer potentiometer are recommended.

(2) Circuit using lock type switch (Current Manual-4 range mode, RMS = " L ")

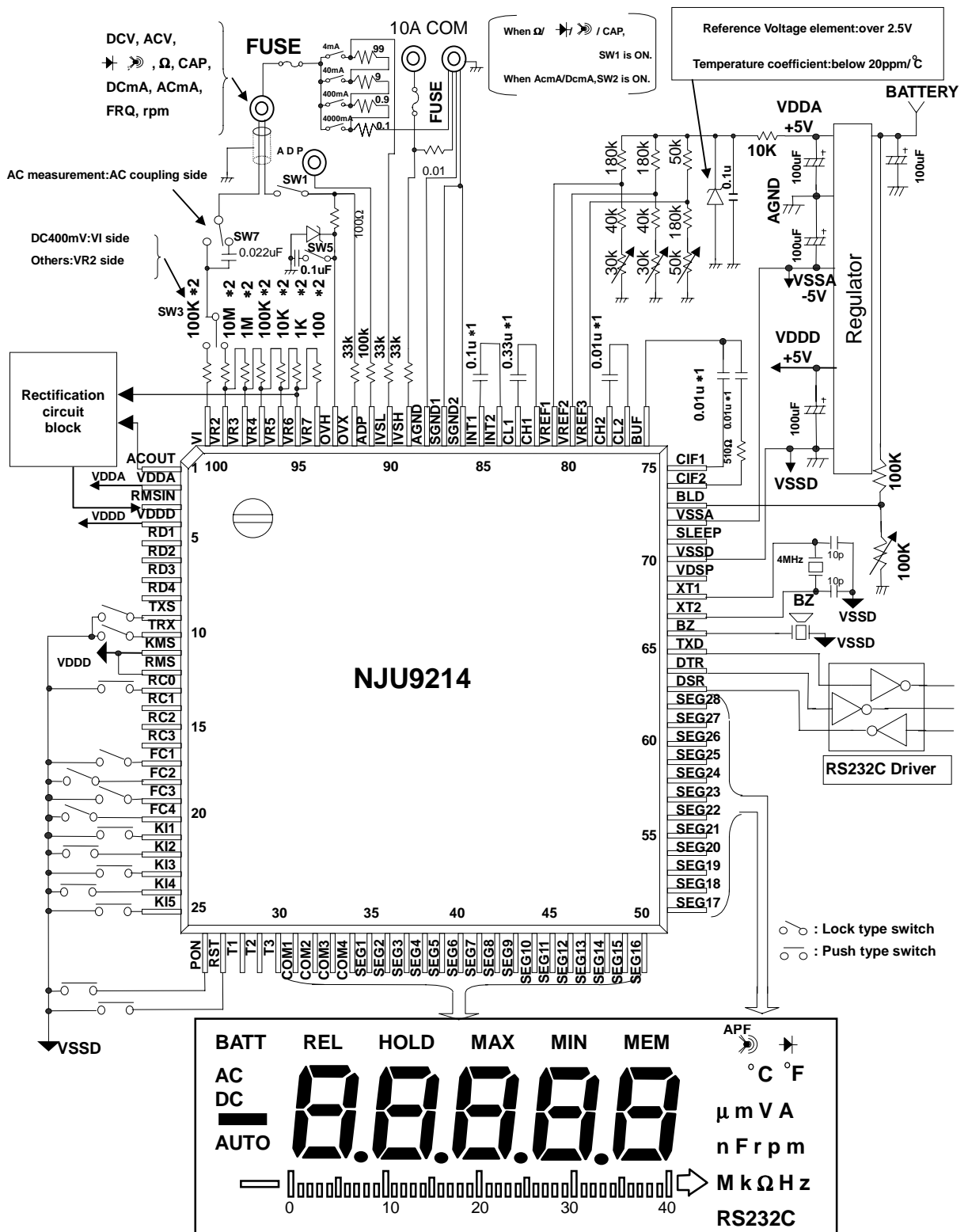

*1 Low-leak capacitors like as the polypropylene film type are required for accurate measurement.

*2 Within 0.01% tolerance resistors or the adjustment by the trimmer potentiometer are recommended.

(3) Circuit using push type switch (Current Auto • Manual-2range mode, KMS = " L ")

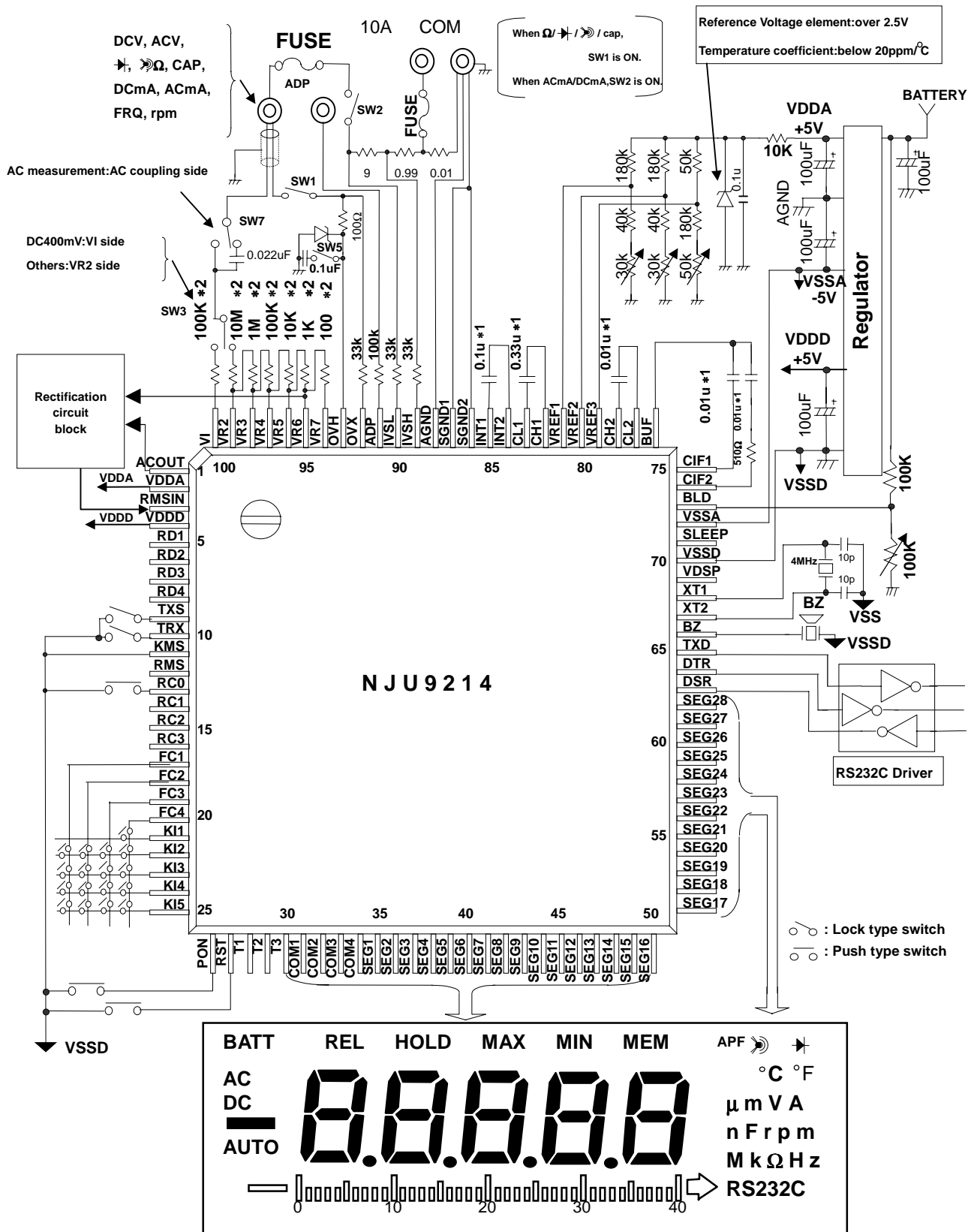

*1 Low-leak capacitors like as the polypropylene film type are required for accurate measurement.
*2 Within 0.01% tolerance resistors or the adjustment by the trimmer potentiometer are recommended.

(4) Application circuit of AC voltage and AC current measurement

In case of AC voltage and AC current measurement, AC-DC conversion is required in the external circuit. In use of the mean square circuit, the measurement circuit realizes low cost system. And also in use of RMS/DC converter, it realizes a root-mean-square measurement. The circuit example using AD736 (Analog Devices,Inc.) is shown below for a root-mean-square measurement.

(The circuit is for only reference, so please refer to the data book of Analog Devices, Inc. for details.)

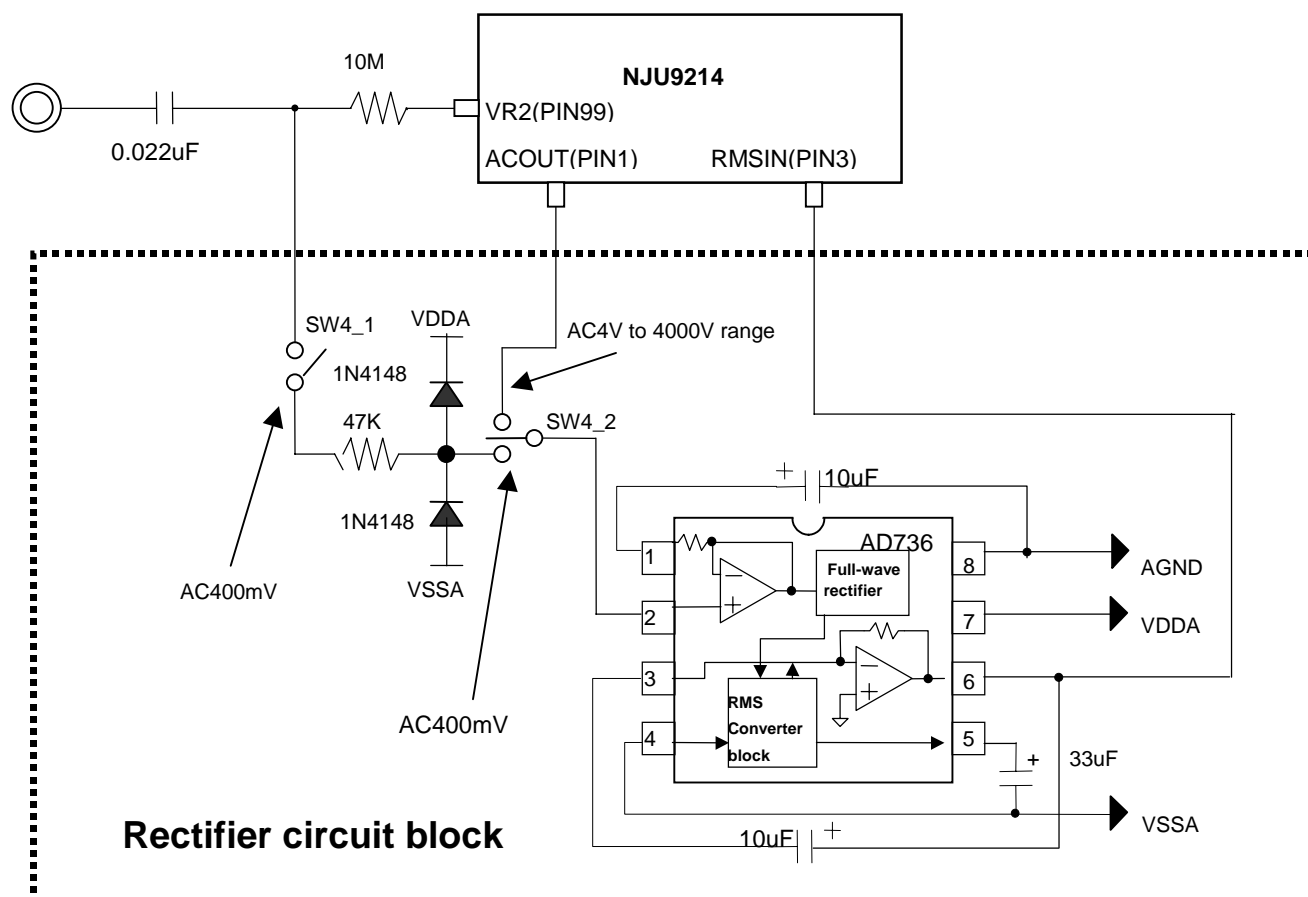

(5) Notes of application circuits

1. The power source for **NJU9214** is required stable, and enough current drivability.
2. Capacitors marked with *1 require low-leak type like as the polypropylene film.
3. Resistance ratio precision of input attenuator block affects measurement precision.
Resistances marked with *2 requires within 0.01% tolerance resistors or adjustment by the trimmer potentiometer.
4. Designing of circuit pattern requires low wiring resistance between AGND terminal and SGND terminal.
5. Constants of resistances for voltage dividing and decoupling capacitor are not guaranteed value as to characteristic. Re adjustment is sometime required depending on elements and peripheral circuit.
6. RMS/DC converter requires full-scale and zero adjustment.

MEMO

[CAUTION]

The specifications on this databook are only given for information, without any guarantee as regards either mistakes or omissions. The application circuits in this databook are described only to show representative usages of the product and not intended for the guarantee or permission of any right including the industrial rights.