

## OVERVIEW

The SM8750AV is a data jitter measurement CMOS LSI for adaptive control.

## FEATURES

- RDCLK and DATA signal phase difference to voltage converter (75mV/ns (typ) coefficient)
- RDCLK duty auto-adjust function (rising edge reference)
- DATA signal delay auto-adjust function (independently adjusted on rising and falling edges)
- Offset auto-calibration function
- 3-wire serial interface mode control
- Sleep function
- Single 5V supply
- 16-pin VSOP

## APPLICATIONS

- Optical disc equipment
  - CD-R
  - CD-RW
  - DVD-RAM
  - Others
- Control/governing equipment

## ORDERING INFORMATION

Device	Package
SM8750AV	16-pin VSOP

## PINOUT

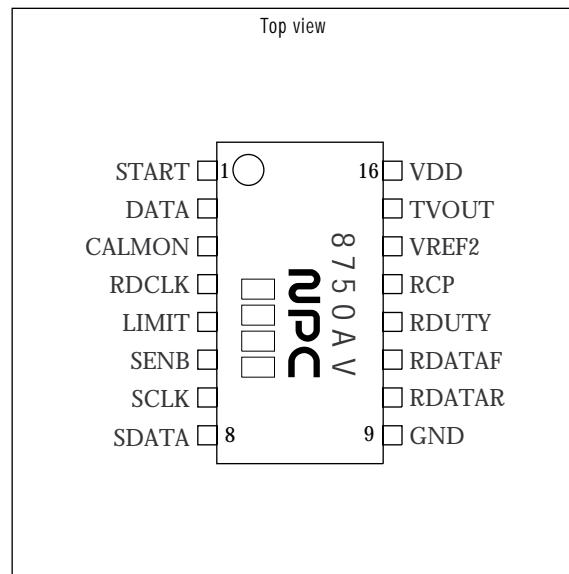

## PACKAGE DIMENSIONS

Unit: mm

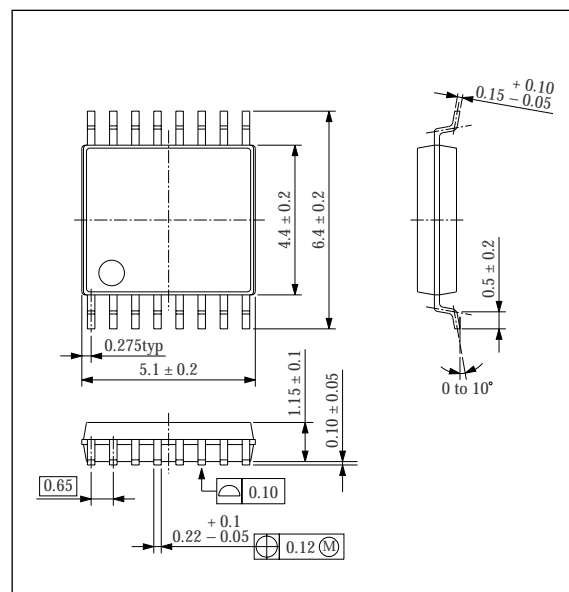

## BLOCK DIAGRAM

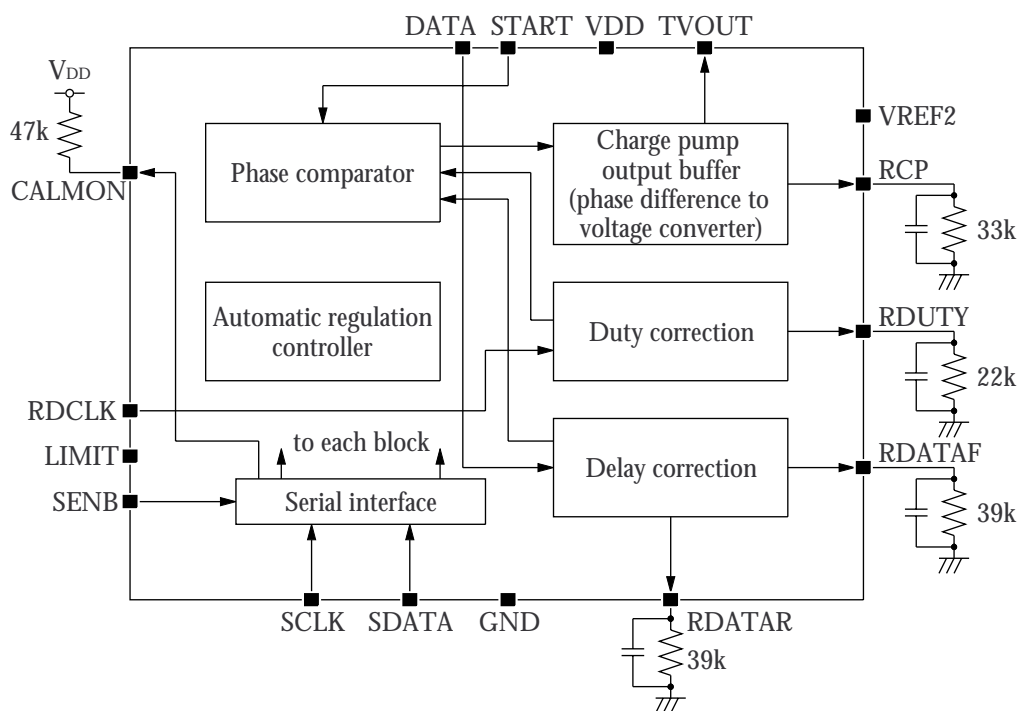

## PIN DESCRIPTION

Number	Name	I/O	Description
1	START	I	Measurement start control. Phase difference to voltage conversion starts on the falling edge.
2	DATA	I	Two-valued signal input
3	CALMON	O	Internal calibration state signal monitor output. N-channel open drain. Active when calibrated.
4	RDCLK	I	PLL clock input
5	LIMIT	I	TVOUT output voltage-limit control voltage input
6	SENB	I	Serial interface: enable signal input
7	SCLK	I	Serial interface: clock signal input
8	SDATA	I/O	Serial interface: data signal input/acknowledge signal output. N-channel open drain.
9	GND	-	Ground
10	RDATAR	O	DATA rising edge: delay adjust circuit reference-current setting resistor connection
11	RDATAF	O	DATA falling edge: delay adjust circuit reference-current setting resistor connection
12	RDUTY	O	RDCLK duty adjust circuit reference-current setting resistor connection
13	RCP	O	Phase difference to voltage converter coefficient reference-current setting resistor connection
14	VREF2	I	2V reference voltage input
15	TVOUT	O	Phase difference to voltage converter output
16	VDD	-	5V supply

## SPECIFICATIONS

### Absolute Maximum Ratings

GND = 0V

Parameter	Symbol	Rating	Unit
Supply voltage range	$V_{DD}$	-0.5 to 7.0	V
Input voltage range	$V_{IN}$	-0.5 to $V_{DD} + 0.5$	V
Storage temperature range	$T_{stg}$	-40 to 125	°C
Power dissipation	$P_D$	250	mW

### Recommended Operating Conditions

GND = 0V

Parameter	Symbol	Rating	Unit
Supply voltage (specifications guaranteed)	$V_{DD}$	4.75 to 5.25	V
Supply voltage (operation guaranteed)	$V_{DD}$	4.5 to 5.5	V
Reference voltage input	$V_{REF2}$	1.89 to 2.11	V
Operating temperature range	$T_{opr}$	0 to 70	°C

### DC Electrical Characteristics

$V_{DD} = 5V \pm 5\%$ , GND = 0V,  $T_a = 0$  to 70°C

Parameter	Symbol	Condition	Rating			Unit
			min	typ	max	
Current consumption <sup>1</sup>	$I_{DD1}$	Normal operating mode	-	9.0	13.0	mA
	$I_{DD2}$	Sleep mode	-	0.5	0.7	
HIGH-level logic input voltage <sup>2</sup>	$V_{IH}$		2.4	-	-	V
LOW-level logic input voltage <sup>2</sup>	$V_{IL}$		-	-	0.6	V
HIGH-level logic input current <sup>2</sup>	$I_{IH}$	$V_{IN} = V_{DD}$	-	-	3	μA
LOW-level logic input current <sup>2</sup>	$I_{IL}$	$V_{IN} = GND$	-3	-	-	μA
SDATA, CALMON logic output voltage	$V_{OL}$	$I_{OL} = 10mA$	-	-	1.0	V
VREF2 input current	$I_{REF}$	$V_{REF2} = 2V$	-	50	100	μA

1. 39kΩ resistor connected between RDATA<sub>R</sub> and GND  
 39kΩ resistor connected between RDATA<sub>F</sub> and GND  
 22kΩ resistor connected between RDUTY and GND  
 33kΩ resistor connected between RCP and GND  
 60MHz RDCLK input frequency  
 7.5MHz DATA input frequency  
 200kHz START input frequency  
 0ns DATA and RDCLK phase difference  
 Serial interface not operating.
2. Pins START, DATA, RDCLK, SENB, SCLK, SDATA.

## Phase Difference to Voltage Converter Characteristics

$V_{DD} = 5V \pm 5\%$ ,  $GND = 0V$ ,  $T_a = 0$  to  $70^\circ\text{C}$

Parameter	Condition	Rating			Unit
		min	typ	max	
RDCLK input frequency	FCG = LOW	-	58.38	70	MHz
	FCG = HIGH	-	29.19	35	
Phase difference to voltage converter coefficient 1	Normal operation, FCG = LOW	50	75	100	mV/ns
Phase difference to voltage converter coefficient 2	Converter coefficient measurement mode, FCG = LOW	25	37.5	50	mV/ns
	Normal operation, FCG = HIGH	25	37.5	50	
Phase difference to voltage converter coefficient 3	Converter coefficient measurement mode, FCG = HIGH	12.5	18.75	25	mV/ns
Converter coefficient relative accuracy	See note. <sup>1</sup>	-	-	$\pm 5$	%
Converter coefficient relative accuracy	See note. <sup>2</sup>	-	-	$\pm 5$	%
Output offset voltage	After VREF2 reference calibration	-	-	$\pm 25$	mV
Converter voltage settling time	Time from measurement object DATA edge to final set value $\pm 0.5\%$	-	-	0.75	$\mu\text{s}$
Converter voltage reset time	Time from START signal rising edge to final reset value $\pm 1\text{mV}$	-	-	3	$\mu\text{s}$
Output load regulation	$I_L = 0.5\text{mA}$	-	-	20	mV
HIGH-level output voltage range	LIMIT pin voltage reference	+0.15	-	+0.45	V
LOW-level output voltage range		0.8	-	-	V
Output voltage droop		-	-	1	mV/ $\mu\text{s}$
START-DATA setup time <sup>3</sup>	START signal rising edge to DATA signal edge	1T	-	-	ns

1.  $\{[(\text{converter coefficient } 2) \times 2 / (\text{converter coefficient } 1)] - 1\} \times 100$

2.  $\{[(\text{converter coefficient } 3) \times 2 / (\text{converter coefficient } 2)] - 1\} \times 100$

3. T = RDCLK cycle time

## Auto-adjust Characteristics

$V_{DD} = 5V \pm 5\%$ ,  $GND = 0V$ ,  $T_a = 0$  to  $70^\circ\text{C}$

Parameter	Condition	Rating			Unit
		min	typ	max	
Maximum DATA edge delay adjust range		-	29	-	ns
Minimum DATA edge delay adjust range		-	12.5	-	ns
Maximum RDCLK pulsewidth adjust range	FCG = LOW	-	15	-	ns
Minimum RDCLK pulsewidth adjust range		-	3	-	ns
Maximum RDCLK pulsewidth adjust range	FCG = HIGH	-	28	-	ns
Minimum RDCLK pulsewidth adjust range		-	4	-	ns
Auto-adjustment time	After CS = HIGH, until settling	-	5	8	ms
RCP voltage	Converter coefficients set	-	1	-	V
HIGH-level RDATAR/RDATAF voltage	Minimum DATA delay	-	1.92	-	V
LOW-level RDATAR/RDATAF voltage	Maximum DATA delay	-	0.69	-	V
HIGH-level RDUTY voltage	Minimum RDCLK pulsewidth	-	1.88	-	V
LOW-level RDUTY voltage	Maximum RDCLK pulsewidth	-	0.24	-	V

**Serial Interface Characteristics**

Parameter	Symbol	Rating			Unit
		min	typ	max	
SCLK pulse cycle time	$t_{cySCK}$	100	-	-	ns
SCLK HIGH-level pulsewidth	$t_{whSCK}$	40	-	-	ns
SCLK LOW-level pulsewidth	$t_{wlSCK}$	40	-	-	ns
SENB setup time	$t_{sSEN}$	20	-	-	ns
SENB hold time	$t_{hSEN}$	40	-	-	ns
SDATA setup time	$t_{sSDA}$	15	-	-	ns
SDATA hold time	$t_{hSDA}$	15	-	-	ns
ACK setup time <sup>1</sup>	$t_{sACK}$	0	-	20	ns
ACK hold time <sup>1</sup>	$t_{hACK}$	-	-	50	ns
SENB interval	$t_{inSEN}$	100	-	-	ns

1. SDATA output signal (ACK) acknowledge output (N-channel open drain), receive data is valid, LOW-level output, 15pF SDATA load capacitance.

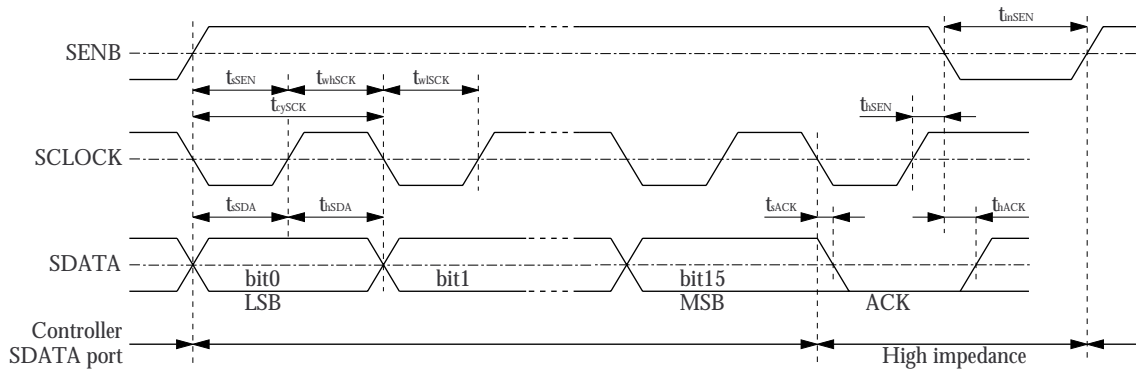

## FUNCTIONAL DESCRIPTION

### Serial Interface

The SM8750AV has a dedicated serial interface port over which data can be written and the various operating modes can be controlled. The port address and

bit configuration are shown in table 1, and the data bits are described in table 2.

Table 1. Port address and bit configuration

Bit number															
15 (msb)	14	13	12	11	10	9	8	7	6	5	4	3	2	1	0 (lsb)
Data								Address							
TEST1	TEST0	CSDIS	CS	SP	POLAR	GMES	FCG	×	LOW	HIGH	HIGH	HIGH	HIGH	HIGH	×

×: Don't care.

Table 2. Data bit description

Bit	Description	Default
TEST[1:0]	Test mode setting	LOW:LOW (normal operation)
CSDIS	Auto-adjust disable	LOW (enabled)
CS	Auto-adjust start	LOW (wait)
SP	Sleep mode settings	LOW (normal operation)
POLAR	DATA edge settings for phase measurement Polarity setting for converter coefficient measurement	LOW (falling edge) (1T discharge)
GMES	Converter coefficient measurement mode setting	LOW (normal operation)
FCG	RDCLK pulsewidth auto-adjust mode Phase difference to voltage converter coefficient switching	LOW (minimum pulsewidth) (maximum converter coefficient)

Table 3. GMES and POLAR operating modes

GMES	POLAR	Operating mode
LOW	LOW	DATA signal falling edge and RDCLK rising edge phase difference conversion
LOW	HIGH	DATA signal rising edge and RDCLK rising edge phase difference conversion
HIGH	LOW	Output converter voltage for phase difference equivalent to $-0.5T$
HIGH	HIGH	Output converter voltage for phase difference equivalent to $+0.5T$

Serial data comprising 16 bits is input with the LSB first. Valid data is read in on the 16th rising edge of the SCLK input. On the next SCLK falling edge, the SDATA N-channel open drain is turned ON and SDATA goes LOW, performing the function of an acknowledge signal.

If 15 or less SCLK rising edge pulses occur during the interval when SENB is HIGH, the data received

up to the point when SENB goes LOW is ignored and the internal port data is not updated. If 17 or more SCLK rising edge pulses occur, the received data is latched in the internal port on the 16th rising edge and the acknowledge signal is output on the next falling edge. The acknowledge signal is held constant until SENB goes LOW again.

## Phase Difference to Voltage Converter

The phase difference to voltage converter circuit takes the converts the phase difference between the RDCLK rising edge and the DATA signal to a voltage. When START goes LOW, the phase difference between the first active DATA signal edge, where the active edge polarity is determined by the serial interface bit POLAR, and the next RDCLK rising edge is converted to a voltage signal. The converted voltage signal is output on TVOUT while START is LOW,

and is reset to the VREF2 reference level when START goes HIGH again.

The START signal must go LOW for a minimum interval of 1 RDCLK cycle before any DATA signal edge to be converted, regardless of the number of DATA signal edges. If the START interval is shorter than 1 cycle, there is a possibility that the next edge might be misinterpreted as the conversion object.

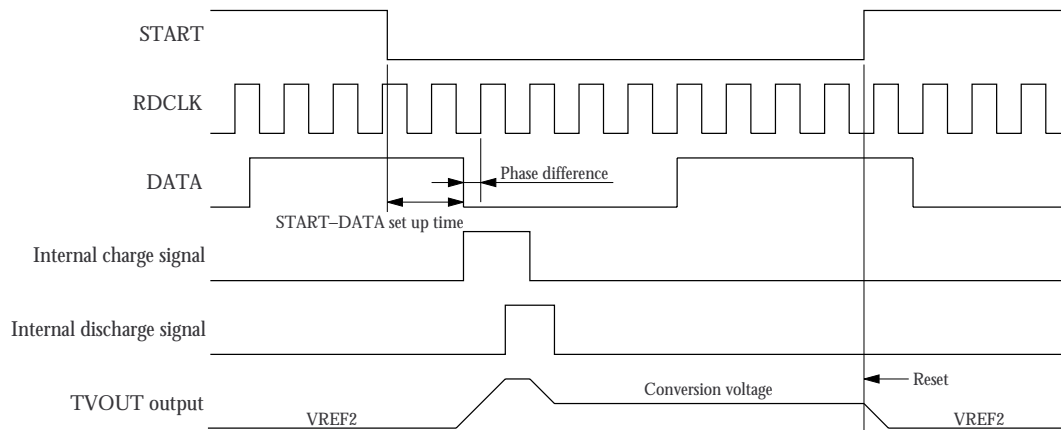

Figure 1. Converter operation timing (POLAR = LOW, DATA leading phase)

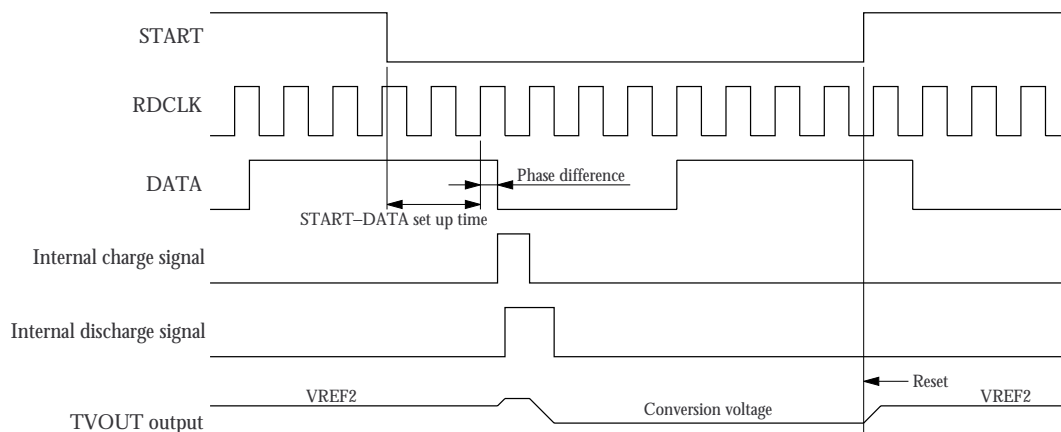

Figure 2. Converter operation timing (POLAR = LOW, DATA lagging phase)

### Converter Coefficient Measurement Mode

When the serial interface bit GMES is set HIGH, converter coefficient measurement mode is invoked. In this mode, a voltage equivalent to a phase difference of  $\pm 0.5T$ , determined by the POLAR input bit, is output on TVOUT. Internally, the difference in

pulsewidth between the charge/discharge signals is  $\pm 1T$ , where the charge pump circuit capacitance is double the capacitance during normal operation in order to generate outputs equivalent to phase differences of  $\pm 0.5T$ .

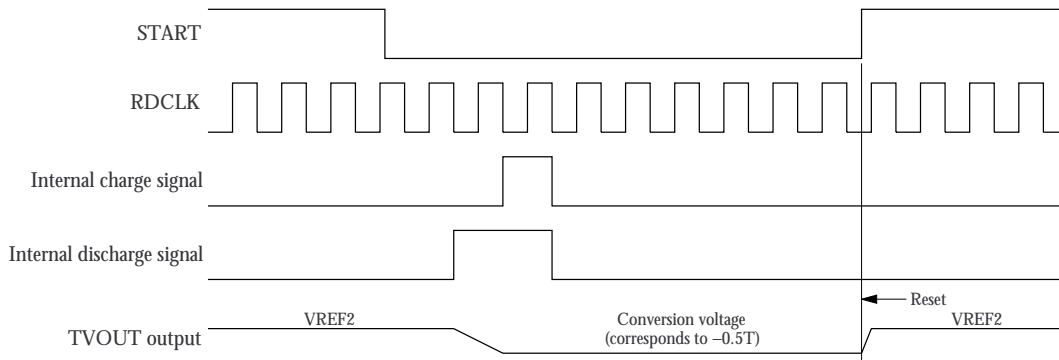

Figure 3. Converter coefficient measurement mode timing (POLAR = LOW)

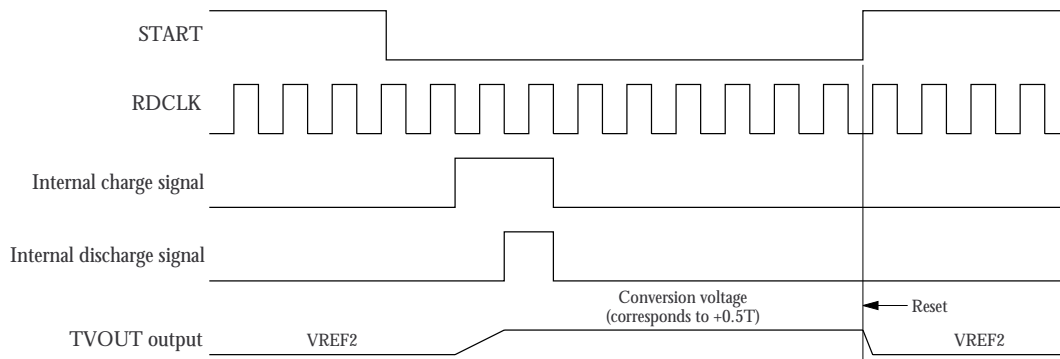

Figure 4. Converter coefficient measurement mode timing (POLAR = HIGH)



## Auto-adjust Function

When the serial interface bit CS is set HIGH, the auto-adjust function starts and operates on the objects in the sequence described below. In the auto-adjust sequence cycle, the RDCLK pulsewidth and DATA delay are set to approximately the center of the adjustment range.

1. Charge pump circuit and output buffer offset cancellation  
An identical 0.5T signal is added to the charge/discharge signals and the output on TVOUT is calibrated to an output voltage of VREF2.
2. RDCLK pulsewidth  
Signals equivalent to the RDCLK HIGH-level pulsewidth and LOW-level pulsewidth are added to the internal charge/discharge signals, and the RDCLK pulsewidths are adjusted to recover a TVOUT output voltage of VREF2.
3. DATA rising edge delay  
The phase difference between the RDCLK rising edge and DATA rising edge is converted to a voltage, and the RDCLK rising edge delay is adjusted to recover a TVOUT output voltage of VREF2.

## Sleep Mode

When the serial interface bit SP is set HIGH, sleep mode is invoked. In this mode, all circuits other than the power-ON detection circuit and serial interface circuit are shutdown to reduce current consumption.

## Power-ON Reset

When power is switched ON, a built-in power-ON reset circuit sets all serial interface bit settings to LOW (factory preset default), and the auto-adjust

## Test Mode

When the serial interface bit TEST1 or TEST0 is set HIGH, a test mode is invoked. In these modes, the phase comparator input signals and internal

### 4. DATA falling edge delay

The phase difference between the RDCLK rising edge and DATA falling edge is converted to a voltage, and the RDCLK rising edge delay is adjusted to recover a TVOUT output voltage of VREF2.

The CALMON calibration monitor output is high impedance during the auto-adjust sequence interval. When auto-adjustment is completed, the CALMON N-channel open drain turns ON and CALMON goes LOW, and the CS bit is cleared to LOW.

When the serial interface bit CSDIS is set HIGH, the auto-adjustment result is disabled, and the external inputs on RDCLK and DATA are input to the phase comparator without adjustment. If CS and CSDIS are both simultaneously set HIGH, the auto-adjust sequence still takes place but that the result is disabled as soon as the sequence is completed.

When power is switched ON, the auto-adjust sequence is enabled, and the adjusted values are approximately in the center of the corresponding adjustment range.

When operation transfers from sleep mode to normal operating mode, the auto-adjust settings from the most recent auto-adjust cycle are restored.

circuit settings are set to the middle of the corresponding adjustment range.

charge/discharge signals are output on CALMON and TVOUT.

Table 4. Test modes

TEST1	TEST0	CALMON	TVOUT
LOW	LOW	Normal operation	Normal operation
LOW	HIGH	Internal charge signal	Internal discharge signal
HIGH	LOW	Phase comparator RDCLK signal	Phase comparator DATA signal

NIPPON PRECISION CIRCUITS INC. reserves the right to make changes to the products described in this data sheet in order to improve the design or performance and to supply the best possible products. Nippon Precision Circuits Inc. assumes no responsibility for the use of any circuits shown in this data sheet, conveys no license under any patent or other rights, and makes no claim that the circuits are free from patent infringement. Applications for any devices shown in this data sheet are for illustration only and Nippon Precision Circuits Inc. makes no claim or warranty that such applications will be suitable for the use specified without further testing or modification. The products described in this data sheet are not intended to use for the apparatus which influence human lives due to the failure or malfunction of the products. Customers are requested to comply with applicable laws and regulations in effect now and hereinafter, including compliance with export controls on the distribution or dissemination of the products. Customers shall not export, directly or indirectly, any products without first obtaining required licenses and approvals from appropriate government agencies.



NIPPON PRECISION CIRCUITS INC.

4-3, Fukuzumi 2-chome  
Koto-ku, Tokyo 135-8430, Japan  
Telephone: 03-3642-6661  
Facsimile: 03-3642-6698

NC9916AE 2000.07