

Connection Diagrams (Continued)

Pin Names	Description
CP	Clock Pulse Input
DS ₀	Serial Data Input for Right Shift
DS ₇	Serial Data Input for Left Shift
S ₀ , S ₁	Mode Select Inputs
$\overline{\text{MR}}$	Asynchronous Master Reset
$\overline{\text{OE}}_1$, $\overline{\text{OE}}_2$	TRI-STATE Output Enable Inputs
I/O ₀ –I/O ₇	Parallel Data Inputs or TRI-STATE Parallel Outputs
Q ₀ , Q ₇	Serial Outputs

Functional Description

The 'AC/ACT299 contains eight edge-triggered D-type flip-flops and the interstage logic necessary to perform synchronous shift left, shift right, parallel load and hold operations. The type of operation is determined by S₀ and S₁, as shown in the Truth Table. All flip-flop outputs are brought out through TRI-STATE buffers to separate I/O pins that also serve as data inputs in the parallel load mode. Q₀ and Q₇ are also brought out on other pins for expansion in serial shifting of longer words.

A LOW signal on $\overline{\text{MR}}$ overrides the Select and CP inputs and resets the flip-flops. All other state changes are initiated by the rising edge of the clock. Inputs can change when the clock is in either state provided only that the recommended setup and hold times, relative to the rising edge of CP, are observed.

A HIGH signal on either $\overline{\text{OE}}_1$ or $\overline{\text{OE}}_2$ disables the TRI-STATE buffers and puts the I/O pins in the high impedance state. In this condition the shift, hold, load and reset operations can still occur. The TRI-STATE buffers are also disabled by HIGH signals on both S₀ and S₁ in preparation for a parallel load operation.

Truth Table

Inputs				Response
MR	S ₁	S ₀	CP	
L	X	X	X	Asynchronous Reset; Q ₀ –Q ₇ = LOW
H	H	H	↗	Parallel Load; I/O _n → Q _n
H	L	H	↗	Shift Right; DS ₀ → Q ₀ , Q ₀ → Q ₁ , etc.
H	H	L	↗	Shift Left; DS ₇ → Q ₇ , Q ₇ → Q ₆ , etc.
H	L	L	X	Hold

H = HIGH Voltage Level
 L = LOW Voltage Level
 X = Immaterial
 ↗ = LOW-to-HIGH Transition

Logic Diagram

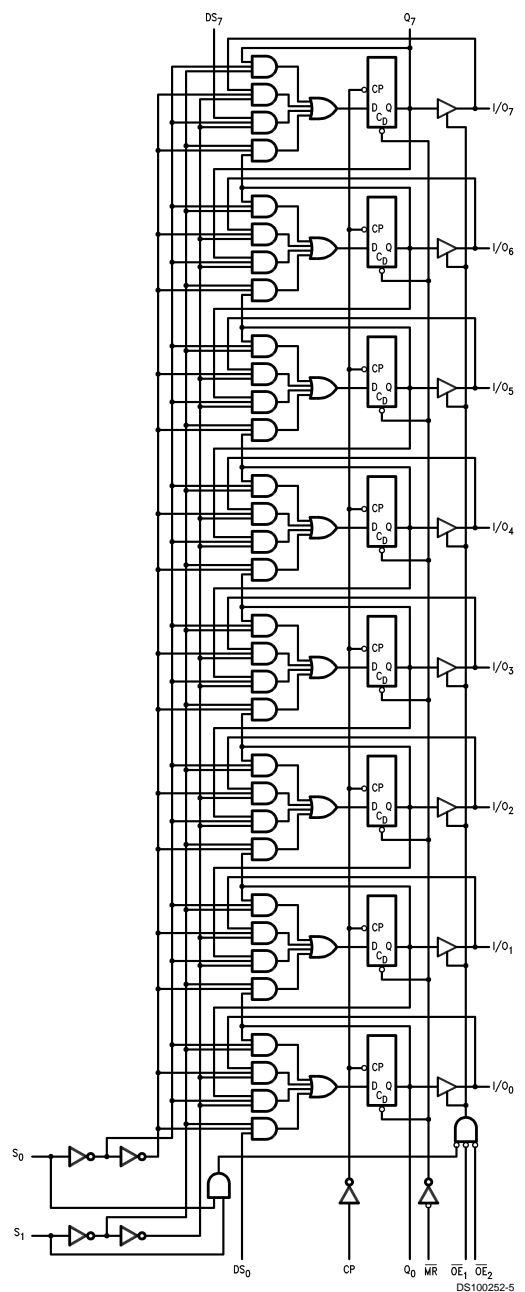

Please note that this diagram is provided only for the understanding of logic operations and should not be used to estimate propagation delays.

Absolute Maximum Ratings (Note 1)

If Military/Aerospace specified devices are required, please contact the National Semiconductor Sales Office/Distributors for availability and specifications.

Supply Voltage (V_{CC})	-0.5V to +7.0V
DC Input Diode Current (I_{IK})	
$V_I = -0.5V$	-20 mA
$V_I = V_{CC} + 0.5V$	+20 mA
DC Input Voltage (V_I)	-0.5V to $V_{CC} + 0.5V$
DC Output Diode Current (I_{OK})	
$V_O = -0.5V$	-20 mA
$V_O = V_{CC} + 0.5V$	+20 mA
DC Output Voltage (V_O)	-0.5V to $V_{CC} + 0.5V$
DC Output Source or Sink Current (I_O)	±50 mA
DC V_{CC} or Ground Current Per Output Pin (I_{CC} or I_{GND})	±50 mA
Storage Temperature (T_{STG})	-65°C to +150°C
Junction Temperature (T_J)	
CDIP	175°C

Recommended Operating Conditions

Supply Voltage (V_{CC}) (Unless Otherwise Specified)	
'AC	2.0V to 6.0V
'ACT	4.5V to 5.0V
Input Voltage (V_I)	0V to V_{CC}
Output Voltage (V_O)	0V to V_{CC}
Operating Temperature (T_A)	
54AC/ACT	-55°C to +125°C
Minimum Input Edge Rate ($\Delta V/\Delta t$)	
'AC Devices	
V_{IN} from 30% to 70% of V_{CC}	
V_{CC} @ 3.3V, 4.5V, 5.5V	125 mV/ns
Minimum Input Edge Rate ($\Delta V/\Delta t$)	
'ACT Devices	
V_{IN} from 0.8V to 2.0V	
V_{CC} @ 4.5V, 5.5V	125 mV/ns

Note 1: Absolute maximum ratings are those values beyond which damage to the device may occur. Obviously the databook specifications should be met, without exception, to ensure that the system design is reliable over its power supply, temperature, and output/input loading variables. National does not recommend operation of FACT® circuits outside databook specifications.

DC Electrical Characteristics

For 'AC Family Devices

Symbol	Parameter	V_{CC} (V)	54AC	Units	Conditions	
			$T_A =$ -55°C to +125°C			
			Guaranteed Limits			
V_{IH}	Minimum High Level Input Voltage	3.0	2.1	V	$V_{OUT} = 0.1V$ or $V_{CC} - 0.1V$	
		4.5	3.15			
		5.5	3.85			
V_{IL}	Maximum Low Level Input Voltage	3.0	0.9	V	$V_{OUT} = 0.1V$ or $V_{CC} - 0.1V$	
		4.5	1.35			
		5.5	1.65			
V_{OH}	Minimum High Level Output Voltage	3.0	2.9	V	$I_{OUT} = -50 \mu A$	
		4.5	4.4			
		5.5	5.4			
			3.0	2.4	V	(Note 2) $V_{IN} = V_{IL}$ or V_{IH} $I_{OH} = -12 \text{ mA}$ $I_{OH} = -24 \text{ mA}$ $I_{OH} = -24 \text{ mA}$
			4.5	3.7		
			5.5	4.7		
V_{OL}	Maximum Low Level Output Voltage	3.0	0.1	V	$I_{OUT} = 50 \mu A$	
		4.5	0.1			
		5.5	0.1			
			3.0	0.50	V	(Note 2) $V_{IN} = V_{IL}$ or V_{IH} $I_{OH} = 12 \text{ mA}$ $I_{OH} = 24 \text{ mA}$ $I_{OH} = 24 \text{ mA}$
			4.5	0.50		
			5.5	0.50		
I_{IN}	Maximum Input Leakage Current	5.5	±1.0	µA	$V_I = V_{CC}, GND$	

Note 2: All outputs loaded; threshold on input associated with output under test.

DC Electrical Characteristics

For 'AC Family Devices

Symbol	Parameter	V _{CC} (V)	54AC	Units	Conditions
			T _A = -55°C to +125°C		
			Guaranteed Limits		
I _{OLD}	(Note 4) Minimum Dynamic	5.5	50	mA	V _{OLD} = 1.65V Max
I _{OHD}	Output Current	5.5	-50	mA	V _{OHD} = 3.85V Min
I _{CC}	Maximum Quiescent Supply Current	5.5	80.0	μA	V _{IN} = V _{CC} or GND
I _{OZT}	Maximum I/O Leakage Current	5.5	±5.5	μA	V _{I(OE)} = V _{IL} , V _{IH} V _I = V _{CC} , GND V _O = V _{CC} , GND

Note 3: All outputs loaded; threshold on input associated with output under test.

Note 4: Maximum test duration 20 ms, one output loaded at a time.

Note 5: I_{IN} and I_{CC} @ 3.0V are guaranteed to be less than or equal to the respective limit @ 5.5V V_{CC}.
I_{CC} for 54AC @ 25°C is identical to 74AC @ 25°C.

DC Electrical Characteristics

For 'ACT Family Devices

Symbol	Parameter	V _{CC} (V)	54ACT	Units	Conditions
			T _A = -55°C to +125°C		
			Guaranteed Limits		
V _{IH}	Minimum High Level Input Voltage	4.5	2.0	V	V _{OUT} = 0.1V or V _{CC} - 0.1V
		5.5	2.0		
V _{IL}	Maximum Low Level Input Voltage	3.0	0.8	V	V _{OUT} = 0.1V or V _{CC} - 0.1V
		4.5	0.8		
V _{OH}	Minimum High Level	4.5	4.4	V	I _{OUT} = -50 μA
		5.5	5.4		
		4.5	3.70	V	(Note 7) V _{IN} = V _{IL} or V _{IH} I _{OH} = -24 mA I _{OH} = -24 mA
V _{OL}	Maximum Low Level Output Voltage	4.5	0.1	V	I _{OUT} = 50 μA
		5.5	0.1		
		4.5	0.50	V	(Note 7) V _{IN} = V _{IL} or V _{IH} I _{OL} = 24 mA I _{OL} = 24 mA
I _{IN}	Maximum Input Leakage Current	5.5	±1.0	μA	V _I = V _{CC} , GND
I _{CCT}	Maximum I _{CC} /Input	5.5	1.6	mA	V _I = V _{CC} - 2.1V
I _{OLD}	(Note 8) Minimum Dynamic	5.5	50	mA	V _{OLD} = 1.65V Max
I _{OHD}	Output Current	5.5	-50	mA	V _{OHD} = 3.85V Min
I _{CC}	Maximum Quiescent Supply Current	5.5	80.0	μA	V _{IN} = V _{CC} or GND
I _{OZT}	Maximum I/O Leakage Current	5.5	±5.0	μA	V _{I(OE)} = V _{IL} , V _{IH} V _I = V _{CC} , GND V _O = V _{CC} , GND

DC Electrical Characteristics (Continued)

Note 6: I_{CC} limit for 54ACT @ 25°C is identical to 74ACT @ 25°C.

Note 7: All outputs loaded; thresholds on input associated with output under test.

Note 8: Maximum test duration 2.0 ms, one output loaded at a time.

Capacitance

Symbol	Parameter	Typ	Units	Conditions
C_{IN}	Input Capacitance	4.5	pF	$V_{CC} = 5.0V$
C_{PD}	Power Dissipation Capacitance	170	pF	$V_{CC} = 5.5V$

AC Electrical Characteristics

Symbol	Parameter	V_{CC} (V) (Note 9)	54AC		Units	Fig. No.
			$T_A = -55^\circ C$ to $+125^\circ C$ $C_L = 50$ pF			
			Min	Max		
f_{max}	Maximum Input Frequency	3.3 5.0	70 80		MHz	
t_{PLH}	Propagation Delay CP to Q_0 or Q_7 (Shift Left or Right)	3.3 5.0	1.0 1.0	25.5 17.5	ns	
t_{PHL}	Propagation Delay CP to Q_0 or Q_7 (Shift Left or Right)	3.3 5.0	1.0 1.0	26.5 18.0	ns	
t_{PLH}	Propagation Delay \overline{CP} to I/O_n	3.3 5.0	1.0 1.0	24.5 17.0	ns	
t_{PHL}	Propagation Delay \overline{CP} to I/O_n	3.3 5.0	1.0 1.0	26.5 18.5	ns	
t_{PHL}	Propagation Delay \overline{MR} to Q_0 or Q_7	3.3 5.0	1.0 1.0	27.0 18.5	ns	
t_{PHL}	Propagation Delay \overline{MR} to I/O_n	3.3 5.0	1.0 1.0	26.5 18.0	ns	
t_{PZH}	Output Enable Time \overline{OE} to I/O_n	3.3 5.0	1.0 1.0	22.0 15.0	ns	
t_{PZL}	Output Enable Time \overline{OE} to I/O_n	3.3 5.0	1.0 1.0	23.5 16.0	ns	
t_{PHZ}	Output Disable Time \overline{OE} to I/O_n	3.3 5.0	1.0 1.0	22.5 17.0	ns	
t_{PLZ}	Output Disable Time \overline{OE} to I/O_n	3.3 5.0	1.0 1.0	21.5 16.0	ns	

Note 9: Voltage Range 3.3 is 3.3V $\pm 0.3V$.

Voltage Range 5.0 is 5.0V $\pm 0.5V$.

AC Operating Requirements

Symbol	Parameter	V _{CC} (V) (Note 10)	54AC		Units	Fig. No.
			T _A = -55°C to +125°C C _L = 50 pF			
			Guaranteed Minimum			
t _s	Setup Time, HIGH or LOW S ₀ or S ₁ to CP	3.3	9.5		ns	
		5.0	7.0			
t _h	Hold Time, HIGH or LOW S ₀ or S ₁ to CP	3.3	2.0		ns	
		5.0	2.5			
t _s	Setup Time, HIGH or LOW I/O _n to CP	3.3	6.0		ns	
		5.0	4.0			
t _h	Hold Time, HIGH or LOW I/O _n to CP	3.3	1.5		ns	
		5.0	2.0			
t _s	Setup Time, HIGH or LOW DS ₀ or DS ₇ to CP	3.3	7.5		ns	
		5.0	5.0			
t _h	Hold Time, HIGH or LOW DS ₀ or DS ₇ to CP	3.3	1.5		ns	
		5.0	1.5			
t _w	CP Pulse Width, LOW	3.3	5.5		ns	
		5.0	5.0			
t _w	$\overline{\text{MR}}$ Pulse Width, LOW	3.3	5.5		ns	
		5.0	5.0			
t _{rec}	Recovery Time $\overline{\text{MR}}$ to CP	3.3	2.5		ns	
		5.0	2.5			

Note 10: Voltage Range 3.3 is 3.3V ±0.3V

Voltage Range 5.0 is 5.0V ±0.5V

AC Electrical Characteristics

Symbol	Parameter	V _{CC} (V) (Note 11)	54ACT		Units	Fig. No.
			T _A = -55°C to +125°C C _L = 50 pF			
			Min	Max		
f _{max}	Maximum Input Frequency	5.0	70		MHz	
t _{PLH}	Propagation Delay CP to Q ₀ or Q ₇ (Shift Left or Right)	5.0	1.0	15.5	ns	
t _{PHL}	Propagation Delay CP to Q ₀ or Q ₇ (Shift Left or Right)	5.0	1.0	16.0	ns	
t _{PLH}	Propagation Delay CP to I/O _n	5.0	1.0	15.0	ns	
t _{PHL}	Propagation Delay CP to I/O _n	5.0	1.0	18.0	ns	
t _{PHL}	Propagation Delay $\overline{\text{MR}}$ to Q ₀ or Q ₇	5.0	1.0	18.0	ns	
t _{PHL}	Propagation Delay $\overline{\text{MR}}$ to I/O _n	5.0	1.0	17.5	ns	

AC Electrical Characteristics (Continued)

Symbol	Parameter	V _{CC} (V) (Note 11)	54ACT		Units	Fig. No.
			T _A = -55°C to +125°C C _L = 50 pF			
			Min	Max		
t _{PZH}	Output Enable Time \overline{OE} to I/O _n	5.0	1.0	14.0	ns	
t _{PZL}	Output Enable Time \overline{OE} to I/O _n	5.0	1.0	14.5	ns	
t _{PHZ}	Output Disable Time \overline{OE} to I/O _n	5.0	1.0	14.5	ns	
t _{PLZ}	Output Disable Time \overline{OE} to I/O _n	5.0	1.0	14.0	ns	

Note 11: Voltage Range 5.0 is 5.0V ±0.5V

AC Operating Requirements

Symbol	Parameter	V _{CC} (V) (Note 12)	54ACT		Units	Fig. No.
			T _A = -55°C to +125°C C _L = 50 pF			
			Guaranteed Minimum			
t _s	Setup Time, HIGH or LOW S ₀ or S ₁ to CP	5.0	6.5		ns	
t _h	Hold Time, HIGH or LOW S ₀ or S ₁ to CP	5.0	1.5		ns	
t _s	Setup Time, HIGH or LOW I/O _n to CP	5.0	4.5		ns	
t _h	Hold Time, HIGH or LOW I/O _n to CP	5.0	1.5		ns	
t _s	Setup Time, HIGH or LOW DS ₀ or DS ₇ to CP	5.0	5.5		ns	
t _h	Hold Time, HIGH or LOW DS ₀ or DS ₇ to CP	5.0	1.5		ns	
t _w	CP Pulse Width HIGH or LOW	5.0	5.0		ns	
t _w	MR Pulse Width, LOW	5.0	5.0		ns	
t _{rec}	Recovery Time MR to CP	5.0	1.5		ns	

Note 12: Voltage Range 5.0 is 5.0V ±0.5V.

Physical Dimensions inches (millimeters) unless otherwise noted

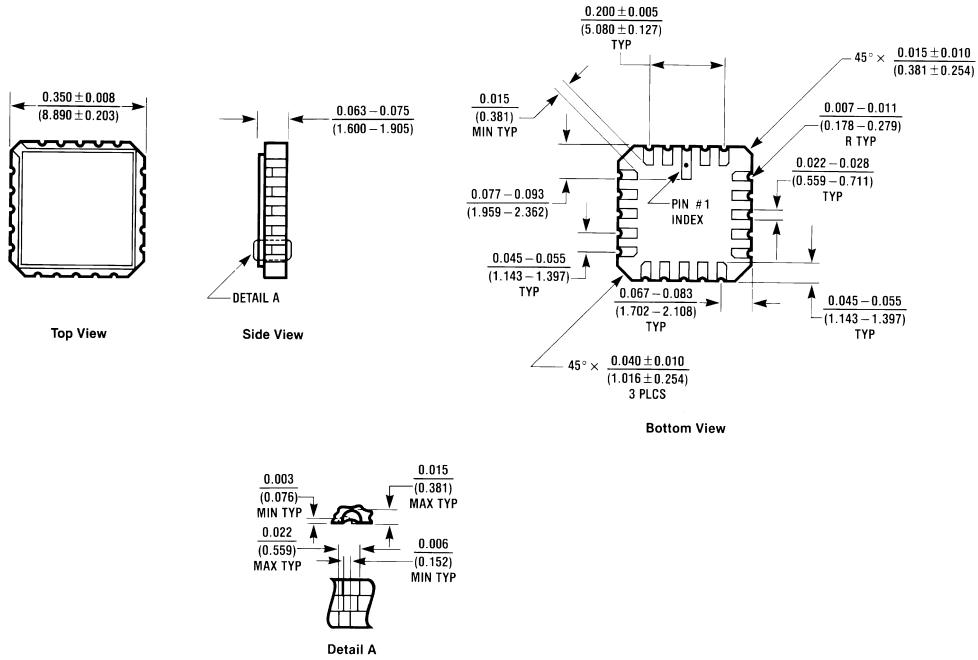

E20A (REV D)

20 Terminal Ceramic Leadless Chip Carrier (LCC)
NS Package Number E20A

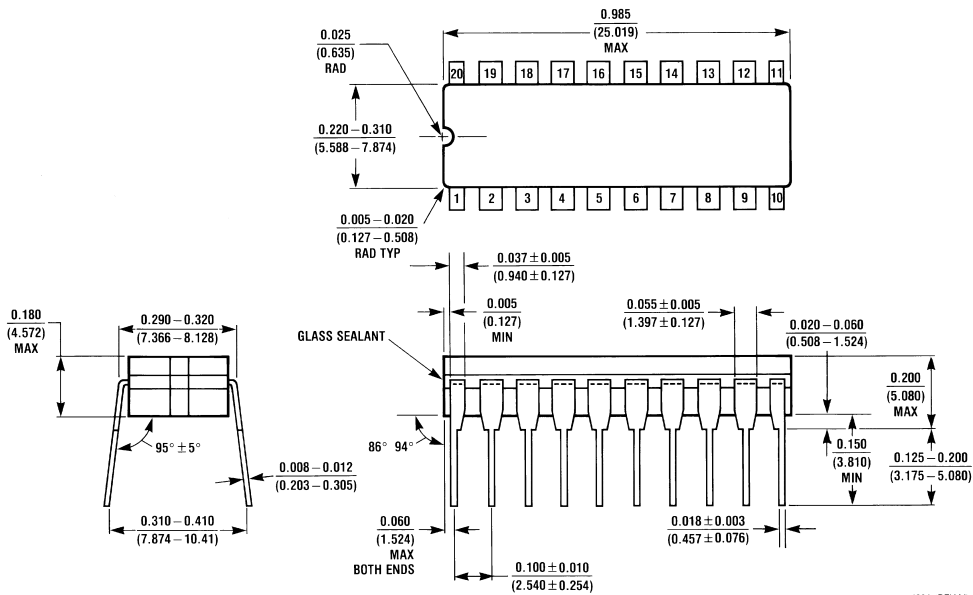

J20A (REV M)

20 Lead Ceramic Dual-In-Line Package (J)
NS Package Number J20A

Physical Dimensions inches (millimeters) unless otherwise noted (Continued)

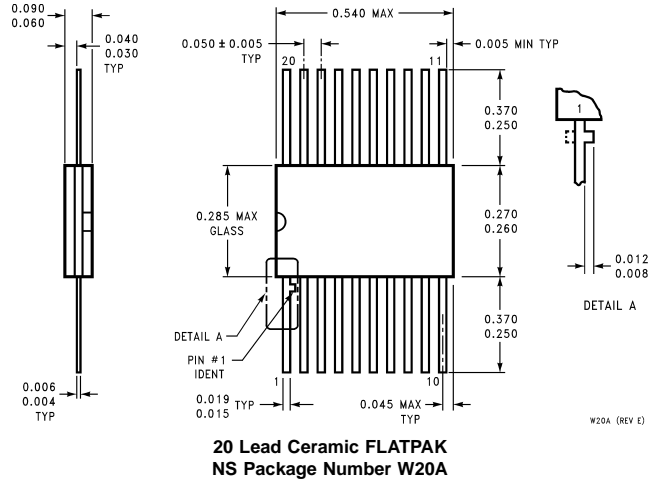

LIFE SUPPORT POLICY

NATIONAL'S PRODUCTS ARE NOT AUTHORIZED FOR USE AS CRITICAL COMPONENTS IN LIFE SUPPORT DEVICES OR SYSTEMS WITHOUT THE EXPRESS WRITTEN APPROVAL OF THE PRESIDENT OF NATIONAL SEMICONDUCTOR CORPORATION. As used herein:

1. Life support devices or systems are devices or systems which, (a) are intended for surgical implant into the body, or (b) support or sustain life, and whose failure to perform when properly used in accordance with instructions for use provided in the labeling, can be reasonably expected to result in a significant injury to the user.
2. A critical component in any component of a life support device or system whose failure to perform can be reasonably expected to cause the failure of the life support device or system, or to affect its safety or effectiveness.



National Semiconductor Corporation
Americas
Tel: 1-800-272-9959
Fax: 1-800-737-7018
Email: support@nsc.com

National Semiconductor Europe
Fax: +49 (0) 1 80-530 85 86
Email: europe.support@nsc.com
Deutsch Tel: +49 (0) 1 80-530 85 85
English Tel: +49 (0) 1 80-532 78 32
Français Tel: +49 (0) 1 80-532 93 58
Italiano Tel: +49 (0) 1 80-534 16 80

National Semiconductor Asia Pacific Customer Response Group
Tel: 65-2544466
Fax: 65-2504466
Email: sea.support@nsc.com

National Semiconductor Japan Ltd.
Tel: 81-3-5620-6175
Fax: 81-3-5620-6179

www.national.com