

## 54AC373 • 54ACT373

### Octal Transparent Latch with TRI-STATE® Outputs

#### General Description

The 'AC/ACT373 consists of eight latches with TRI-STATE outputs for bus organized system applications. The flip-flops appear transparent to the data when Latch Enable (LE) is HIGH. When LE is LOW, the data that meets the setup time is latched. Data appears on the bus when the Output Enable ( $\overline{OE}$ ) is LOW. When  $\overline{OE}$  is HIGH, the bus output is in the high impedance state.

#### Features

- $I_{CC}$  and  $I_{OZ}$  reduced by 50%
- Eight latches in a single package
- TRI-STATE outputs for bus interfacing
- Outputs source/sink 24 mA
- 'ACT373 has TTL-compatible inputs
- Standard Microcircuit Drawing (SMD)
  - 'AC373: 5962-87555
  - 'ACT373: 5962-87556

#### Logic Symbols

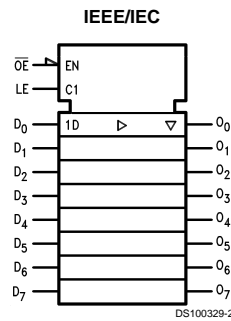
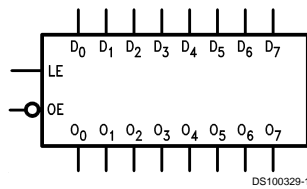

Pin Names	Description
D <sub>0</sub> -D <sub>7</sub>	Data Inputs
LE	Latch Enable Input
$\overline{OE}$	Output Enable Input
O <sub>0</sub> -O <sub>7</sub>	TRI-STATE Latch Outputs

TRI-STATE® is a registered trademark of National Semiconductor Corporation.  
FACT® is a registered trademark of Fairchild Semiconductor Corporation.

## Connection Diagrams

Pin Assignment for DIP and Flatpak

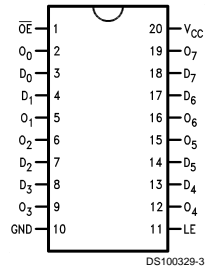

Pin Assignment for LCC

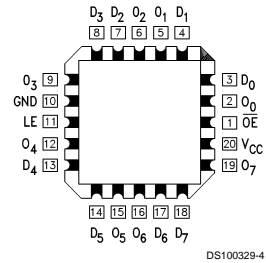

## Functional Description

The 'AC/ACT373 contains eight D-type latches with TRI-STATE standard outputs. When the Latch Enable (LE) input is HIGH, data on the  $D_n$  inputs enters the latches. In this condition the latches are transparent, i.e., a latch output will change state each time its D input changes. When LE is LOW, the latches store the information that was present on the D inputs a setup time preceding the HIGH-to-LOW transition of LE. The TRI-STATE standard outputs are controlled by the Output Enable ( $\overline{OE}$ ) input. When  $\overline{OE}$  is LOW, the standard outputs are in the 2-state mode. When  $\overline{OE}$  is HIGH, the standard outputs are in the high impedance mode but this does not interfere with entering new data into the latches.

## Truth Table

LE	Inputs		Outputs
	$\overline{OE}$	$D_n$	$O_n$
X	H	X	Z
H	L	L	L
H	L	H	H
L	L	X	$O_0$

H = HIGH Voltage Level

L = LOW Voltage Level

Z = High Impedance

X = Immaterial

$O_0$  = Previous  $O_0$  before HIGH to Low transition of Latch Enable

## Logic Diagram

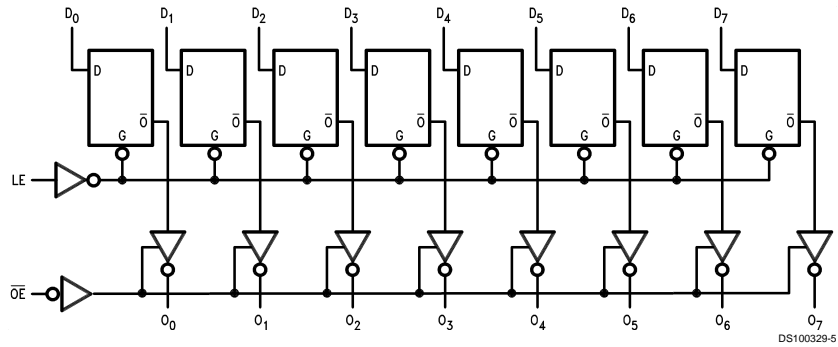

Please note that this diagram is provided only for the understanding of logic operations and should not be used to estimate propagation delays.

## Absolute Maximum Ratings (Note 1)

If Military/Aerospace specified devices are required, please contact the National Semiconductor Sales Office/Distributors for availability and specifications.

Supply Voltage ( $V_{CC}$ )	-0.5V to +7.0V
DC Input Diode Current ( $I_{IK}$ )	
$V_I = -0.5V$	-20 mA
$V_I = V_{CC} + 0.5V$	+20 mA
DC Input Voltage ( $V_I$ )	-0.5V to $V_{CC} + 0.5V$
DC Output Diode Current ( $I_{OK}$ )	
$V_O = -0.5V$	-20 mA
$V_O = V_{CC} + 0.5V$	+20 mA
DC Output Voltage ( $V_O$ )	-0.5V to $V_{CC} + 0.5V$
DC Output Source or Sink Current ( $I_O$ )	$\pm 50$ mA
DC $V_{CC}$ or Ground Current per Output Pin ( $I_{CC}$ or $I_{GND}$ )	$\pm 50$ mA
Storage Temperature ( $T_{STG}$ )	-65°C to +150°C
Junction Temperature ( $T_J$ )	
CDIP	175°C

## Recommended Operating Conditions

Supply Voltage ( $V_{CC}$ )	
'AC	2.0V to 6.0V
'ACT	4.5V to 5.5V
Input Voltage ( $V_I$ )	0V to $V_{CC}$
Output Voltage ( $V_O$ )	0V to $V_{CC}$
Operating Temperature ( $T_A$ )	
54AC/ACT	-55°C to +125°C
Minimum Input Edge Rate ( $\Delta V/\Delta t$ )	
'AC Devices	
$V_{IN}$ from 30% to 70% of $V_{CC}$	
$V_{CC}$ @ 3.3V, 4.5V, 5.5V	125 mV/ns
Minimum Input Edge Rate ( $\Delta V/\Delta t$ )	
'ACT Devices	
$V_{IN}$ from 0.8V to 2.0V	
$V_{CC}$ @ 4.5V, 5.5V	125 mV/ns

**Note 1:** Absolute maximum ratings are those values beyond which damage to the device may occur. The databook specifications should be met, without exception, to ensure that the system design is reliable over its power supply, temperature, and output/input loading variables. National does not recommend operation of FACT® circuits outside databook specifications.

## DC Characteristics for 'AC Family Devices

Symbol	Parameter	$V_{CC}$ (V)	54AC		Units	Conditions	
			$T_A =$ -55°C to +125°C				
			Guaranteed Limits				
$V_{IH}$	Minimum High Level Input Voltage	3.0	2.1		V	$V_{OUT} = 0.1V$ or $V_{CC} - 0.1V$	
		4.5	3.15				
		5.5	3.85				
$V_{IL}$	Maximum Low Level Input Voltage	3.0	0.9		V	$V_{OUT} = 0.1V$ or $V_{CC} - 0.1V$	
		4.5	1.35				
		5.5	1.65				
$V_{OH}$	Minimum High Level Output Voltage	3.0	2.9		V	$I_{OUT} = -50 \mu A$	
		4.5	4.4				
		5.5	5.4				
			3.0	2.4		V	(Note 2) $V_{IN} = V_{IL}$ or $V_{IH}$  $I_{OH}$
			4.5	3.7			
			5.5	4.7			
$V_{OL}$	Maximum Low Level Output Voltage	3.0	0.1		V	$I_{OUT} = 50 \mu A$	
		4.5	0.1				
		5.5	0.1				
			3.0	0.50		V	(Note 2) $V_{IN} = V_{IL}$ or $V_{IH}$  $I_{OL}$
			4.5	0.50			
			5.5	0.50			
$I_{IN}$	Maximum Input Leakage Current	5.5	$\pm 1.0$		$\mu A$	$V_I = V_{CC}, GND$	

### DC Characteristics for 'AC Family Devices (Continued)

Symbol	Parameter	V <sub>CC</sub> (V)	54AC	Units	Conditions
			T <sub>A</sub> = -55°C to +125°C		
			Guaranteed Limits		
I <sub>OZ</sub>	Maximum TRI-STATE Current	5.5	±5.0	μA	V <sub>I</sub> (OE) = V <sub>IL</sub> , V <sub>IH</sub> V <sub>I</sub> = V <sub>CC</sub> , GND V <sub>O</sub> = V <sub>CC</sub> , GND
I <sub>OLD</sub>	(Note 3) Minimum Dynamic Output Current	5.5	50	mA	V <sub>OLD</sub> = 1.65V Max
I <sub>OHD</sub>	Output Current	5.5	-50	mA	V <sub>OHD</sub> = 3.85V Min
I <sub>CC</sub>	Maximum Quiescent Supply Current	5.5	80.0	μA	V <sub>IN</sub> = V <sub>CC</sub> or GND

**Note 2:** All outputs loaded, thresholds on input associated with output under test.

**Note 3:** Maximum test duration 2.0 ms, one output loaded at a time.

**Note 4:** I<sub>IN</sub> and I<sub>CC</sub> @ 3.0V are guaranteed to be less than or equal to the respective limit @ 5.5V V<sub>CC</sub>.

I<sub>CC</sub> for 54AC @ 25°C is identical to 74AC @ 25°C.

### DC Characteristics for 'ACT Family Devices

Symbol	Parameter	V <sub>CC</sub> (V)	54ACT	Units	Conditions
			T <sub>A</sub> = -55°C to +125°C		
			Guaranteed Limits		
V <sub>IH</sub>	Minimum High Level Input Voltage	4.5	2.0	V	V <sub>OUT</sub> = 0.1V or V <sub>CC</sub> - 0.1V
		5.5	2.0		
V <sub>IL</sub>	Maximum Low Level Input Voltage	4.5	0.8	V	V <sub>OUT</sub> = 0.1V or V <sub>CC</sub> - 0.1V
		5.5	0.8		
V <sub>OH</sub>	Minimum High Level Output Voltage	4.5	4.4	V	I <sub>OUT</sub> = -50 μA
		5.5	5.4		
		4.5	3.70	V	(Note 5) V <sub>IN</sub> = V <sub>IL</sub> or V <sub>IH</sub> I <sub>OH</sub> -24 mA -24 mA
		5.5	4.70		
V <sub>OL</sub>	Maximum Low Level Output Voltage	4.5	0.1	V	I <sub>OUT</sub> = 50 μA
		5.5	0.1		
		4.5	0.50	V	(Note 5) V <sub>IN</sub> = V <sub>IL</sub> or V <sub>IH</sub> I <sub>OL</sub> 24 mA 24 mA
		5.5	0.50		
I <sub>IN</sub>	Maximum Input Leakage Current	5.5	±1.0	μA	V <sub>I</sub> = V <sub>CC</sub> , GND
I <sub>OZ</sub>	Maximum TRI-STATE Current	5.5	±5.0	μA	V <sub>I</sub> = V <sub>IL</sub> , V <sub>IH</sub> V <sub>O</sub> = V <sub>CC</sub> , GND
I <sub>CCT</sub>	Maximum I <sub>CC</sub> /Input	5.5	1.6	mA	V <sub>I</sub> = V <sub>CC</sub> - 2.1V
I <sub>OLD</sub>	(Note 6) Minimum Dynamic	5.5	50	mA	V <sub>OLD</sub> = 1.65V Max
I <sub>OHD</sub>	Output Current	5.5	-50	mA	V <sub>OHD</sub> = 3.85V Min
I <sub>CC</sub>	Maximum Quiescent Supply Current	5.5	80.0	μA	V <sub>IN</sub> = V <sub>CC</sub> or GND

**Note 5:** All outputs loaded; thresholds on input associated with output under test.

**Note 6:** Maximum test duration 2.0 ms, one output loaded at a time.

**Note 7:** I<sub>CC</sub> for 54ACT @ 25°C is identical to 74ACT @ 25°C.

## AC Electrical Characteristics

Symbol	Parameter	V <sub>CC</sub> (V) (Note 8)	54AC		Units
			T <sub>A</sub> = -55°C to +125°C C <sub>L</sub> = 50 pF		
			Min	Max	
t <sub>PLH</sub>	Propagation Delay D <sub>n</sub> to O <sub>n</sub>	3.3	1.0	16.5	ns
		5.0	1.5	11.5	
t <sub>PHL</sub>	Propagation Delay D <sub>n</sub> to O <sub>n</sub>	3.3	1.0	16.0	ns
		5.0	1.5	11.5	
t <sub>PLH</sub>	Propagation Delay LE to O <sub>n</sub>	3.3	1.0	16.5	ns
		5.0	1.5	12.0	
t <sub>PHL</sub>	Propagation Delay LE to O <sub>n</sub>	3.3	1.0	15.0	ns
		5.0	1.5	11.0	
t <sub>PZH</sub>	Output Enable Time	3.3	1.0	14.0	ns
		5.0	1.5	10.5	
t <sub>PZL</sub>	Output Enable Time	3.3	1.0	13.5	ns
		5.0	1.5	10.0	
t <sub>PHZ</sub>	Output Disable Time	3.3	1.0	16.0	ns
		5.0	1.5	13.5	
t <sub>PLZ</sub>	Output Disable Time	3.3	1.0	13.0	ns
		5.0	1.5	10.5	

**Note 8:** Voltage Range 3.3 is 3.3V ±0.3V  
Voltage Range 5.0 is 5.0V ±0.5V

## AC Operating Requirements

Symbol	Parameter	V <sub>CC</sub> (V) (Note 9)	54AC		Units	Fig. No.
			T <sub>A</sub> = -55°C to +125°C C <sub>L</sub> = 50 pF			
			Guaranteed Minimum			
t <sub>s</sub>	Setup Time, HIGH or LOW D <sub>n</sub> to LE	3.3	6.5		ns	
		5.0	5.0			
t <sub>h</sub>	Hold Time, HIGH or LOW D <sub>n</sub> to LE	3.3	1.0		ns	
		5.0	1.0			
t <sub>w</sub>	LE Pulse Width, HIGH	3.3	6.5		ns	
		5.0	5.0			

**Note 9:** Voltage Range 3.3 is 3.3V ±0.3V  
Voltage Range 5.0 is 5.0V ±0.5V

## AC Electrical Characteristics

Symbol	Parameter	V <sub>CC</sub> (V) (Note 10)	54ACT		Units
			T <sub>A</sub> = -55°C to +125°C C <sub>L</sub> = 50 pF		
			Min	Max	
t <sub>PLH</sub>	Propagation Delay D <sub>n</sub> to O <sub>n</sub>	5.0	1.5	12.5	ns
t <sub>PHL</sub>	Propagation Delay D <sub>n</sub> to O <sub>n</sub>	5.0	1.5	12.5	ns
t <sub>PLH</sub>	Propagation Delay LE to O <sub>n</sub>	5.0	1.5	12.5	ns
t <sub>PHL</sub>	Propagation Delay LE to O <sub>n</sub>	5.0	1.5	11.5	ns
t <sub>PZH</sub>	Output Enable Time	5.0	1.5	11.5	ns
t <sub>PZL</sub>	Output Enable Time	5.0	1.5	11.0	ns
t <sub>PHZ</sub>	Output Disable Time	5.0	1.5	14.0	ns
t <sub>PLZ</sub>	Output Disable Time	5.0	1.5	11.0	ns

Note 10: Voltage Range 5.0 is 5.0V ±0.5V

## AC Operating Requirements

Symbol	Parameter	V <sub>CC</sub> (V) (Note 11)	54ACT		Units
			T <sub>A</sub> = -55°C to +125°C C <sub>L</sub> = 50 pF		
			Guaranteed Minimum		
t <sub>s</sub>	Setup Time, HIGH or LOW D <sub>n</sub> to LE	5.0	8.5		ns
t <sub>h</sub>	Hold Time, HIGH or LOW D <sub>n</sub> to LE	5.0	1.0		ns
t <sub>w</sub>	LE Pulse Width, HIGH	5.0	8.5		ns

Note 11: Voltage Range 5.0 is 5.0V ±0.5V

## Capacitance

Symbol	Parameter	Typ	Units	Conditions
C <sub>IN</sub>	Input Capacitance	4.5	pF	V <sub>CC</sub> = OPEN
C <sub>PD</sub>	Power Dissipation Capacitance	40.0	pF	V <sub>CC</sub> = 5.0V

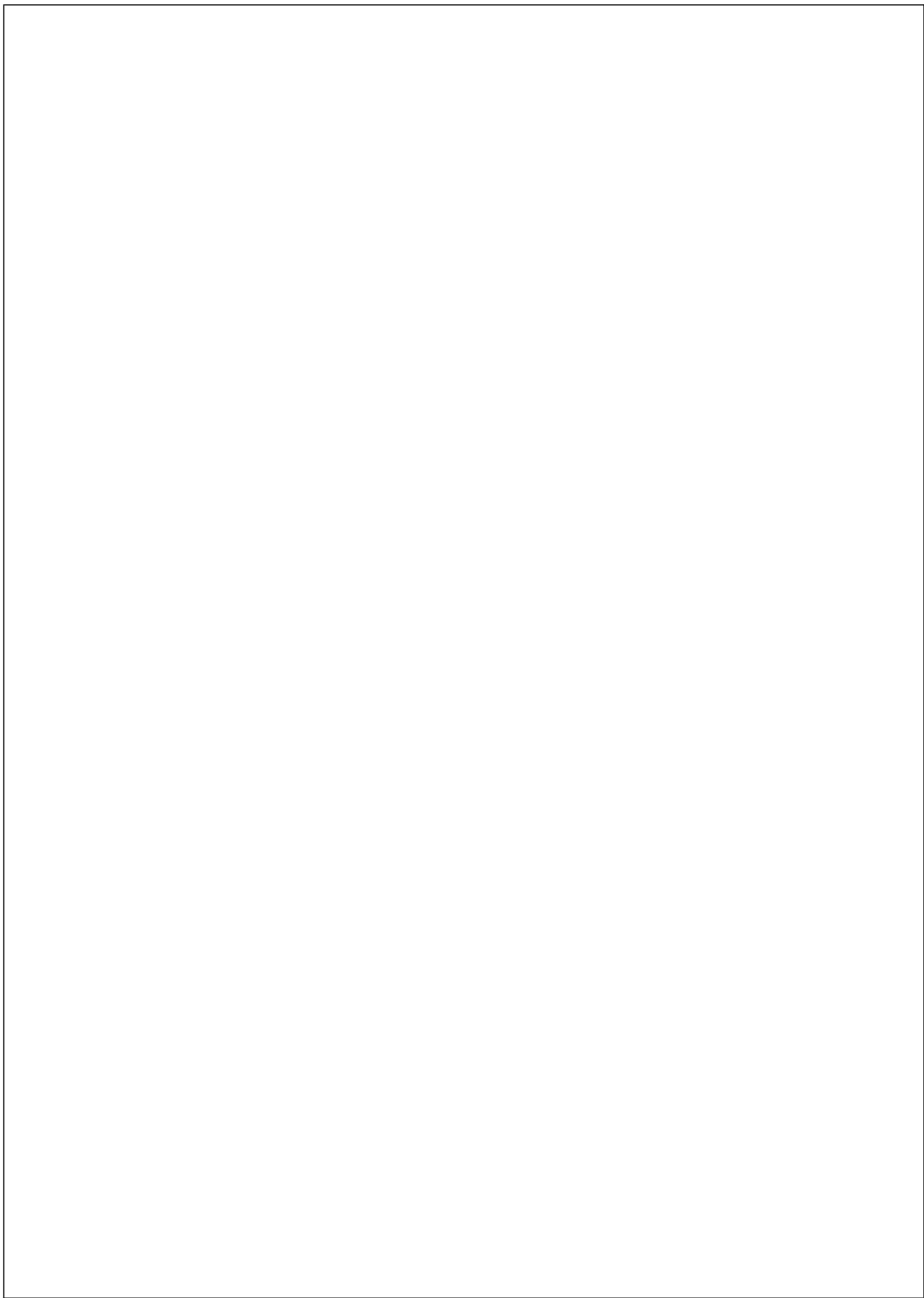



**Physical Dimensions** inches (millimeters) unless otherwise noted

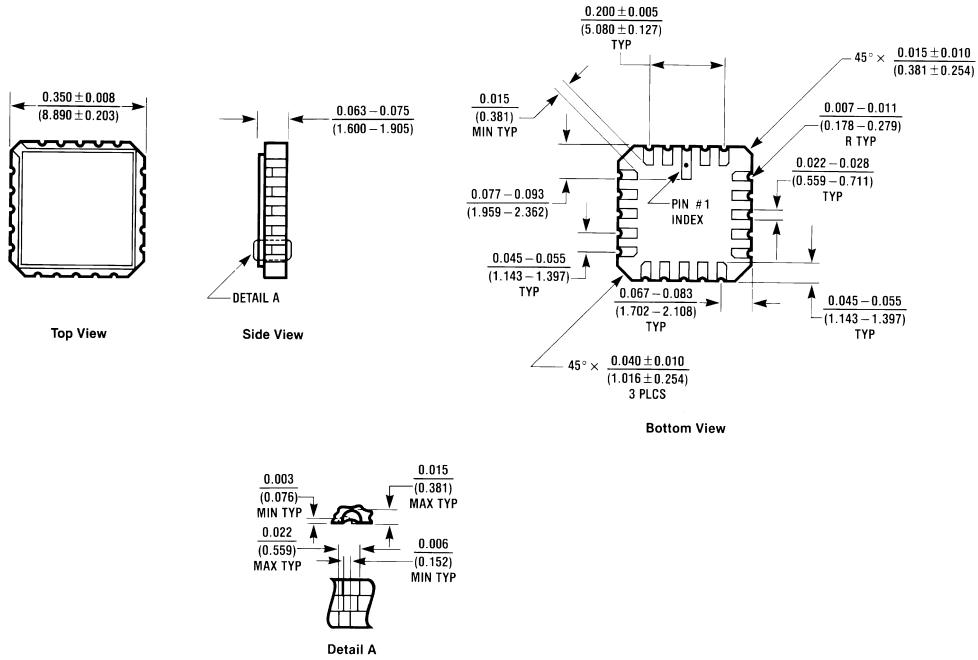

E20A (REV. D)

**20 Terminal Ceramic Leadless Chip Carrier (L)  
 NS Package Number E20A**

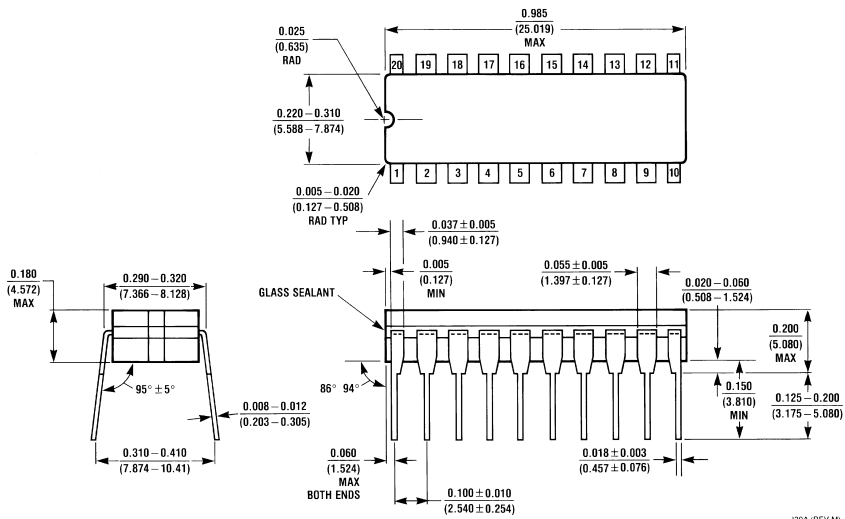

J20A (REV. M)

**20 Lead Ceramic Dual-In-Line Package (D)  
 NS Package Number J20A**

**Physical Dimensions** inches (millimeters) unless otherwise noted (Continued)

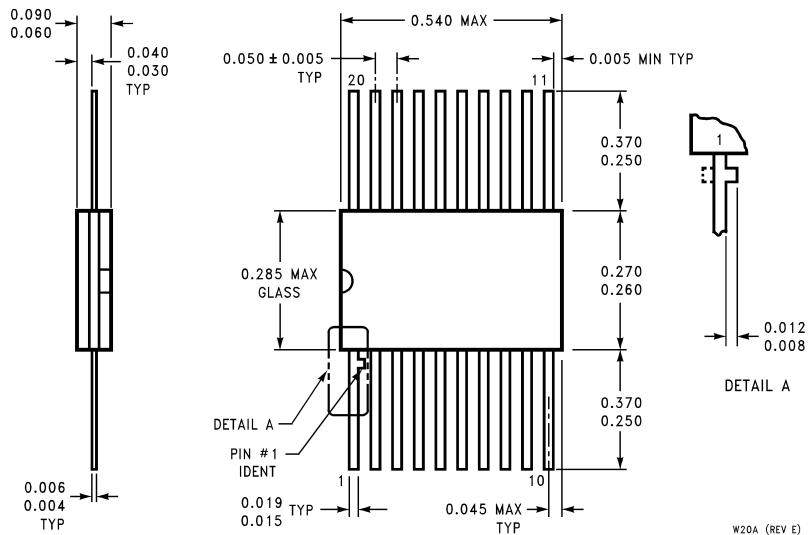

**20-Lead Ceramic Flatpak (F)  
NS Package Number W20A**

**LIFE SUPPORT POLICY**

NATIONAL'S PRODUCTS ARE NOT AUTHORIZED FOR USE AS CRITICAL COMPONENTS IN LIFE SUPPORT DEVICES OR SYSTEMS WITHOUT THE EXPRESS WRITTEN APPROVAL OF THE PRESIDENT OF NATIONAL SEMICONDUCTOR CORPORATION. As used herein:

1. Life support devices or systems are devices or systems which, (a) are intended for surgical implant into the body, or (b) support or sustain life, and whose failure to perform when properly used in accordance with instructions for use provided in the labeling, can be reasonably expected to result in a significant injury to the user.
2. A critical component in any component of a life support device or system whose failure to perform can be reasonably expected to cause the failure of the life support device or system, or to affect its safety or effectiveness.



**National Semiconductor Corporation**  
Americas  
Tel: 1-800-272-9959  
Fax: 1-800-737-7018  
Email: support@nsc.com

www.national.com

**National Semiconductor Europe**  
Fax: +49 (0) 1 80-530 85 86  
Email: europe.support@nsc.com  
Deutsch Tel: +49 (0) 1 80-530 85 85  
English Tel: +49 (0) 1 80-532 78 32  
Français Tel: +49 (0) 1 80-532 93 58  
Italiano Tel: +49 (0) 1 80-534 16 80

**National Semiconductor Asia Pacific Customer Response Group**  
Tel: 65-2544466  
Fax: 65-2504466  
Email: sea.support@nsc.com

**National Semiconductor Japan Ltd.**  
Tel: 81-3-5620-6175  
Fax: 81-3-5620-6179