

54ACTQ541

Quiet Series Octal Buffer/Line Driver with TRI-STATE® Outputs

General Description

The 'ACTQ541 is an octal buffer and line driver with TRI-STATE outputs designed to be employed as a memory and address driver, clock driver, or bus-oriented transmitter/receiver.

The 'ACTQ541 is similar to the 'ACTQ244 while providing flow-through architecture (inputs on opposite sides from outputs). This pinout arrangement makes this device especially useful as an output port for microprocessors, allowing ease of layout and greater PC board density.

The 'ACTQ541 utilizes NSC Quiet Series technology to guarantee quiet output switching and improved dynamic threshold performance. FACT Quiet Series™ features GTO™ output control and undershoot corrector in addition to a split ground bus for superior AC MOS performance.

Features

- Non-inverting buffers
- Guaranteed simultaneous switching noise level and dynamic threshold performance
- Flow-through pinout for ease of PC board layout
- Non-inverting TRI-STATE™ outputs
- TTL compatible inputs
- CMOS power consumption
- Output source/sink 24 mA
- Standard Microcircuit Drawing (SMD) 5962-9682901

Connection Diagram

Pin Assignment
DIP and Cerpack

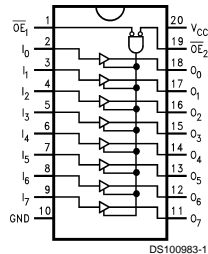

Pin Assignment
LCC

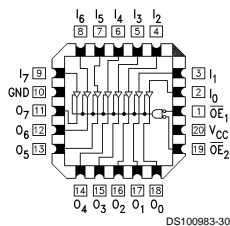

Pin Names	Description
$\overline{OE}_1, \overline{OE}_2$	Output Enable Input (Active Low)
I_0-I_7	Inputs
O_0-O_7	Outputs

Truth Table

Inputs		Outputs	
\overline{OE}_1	\overline{OE}_2	I	ACTQ541
L	L	H	H
H	X	X	Z
X	H	X	Z
L	L	L	L

H = HIGH Voltage Level
L = LOW Voltage Level
X = Immaterial
Z = High Impedance

GTO™ is a trademark of National Semiconductor Corporation.
TRI-STATE® is a registered trademark of National Semiconductor Corporation.
FACT™ and FACT Quiet Series™ are trademarks of Fairchild Semiconductor Corporation.

Absolute Maximum Ratings (Note 1)

If Military/Aerospace specified devices are required, please contact the National Semiconductor Sales Office/Distributors for availability and specifications.

Supply Voltage (V_{CC})	-0.5V to +7.0V
DC Input Diode Current (I_{IK})	
$V_I = -0.5V$	-20 mA
$V_I = V_{CC} + 0.5V$	+20 mA
DC Input Voltage (V_I)	-0.5V to $V_{CC} + 0.5V$
DC Output Diode Current (I_{OK})	
$V_O = -0.5V$	-20 mA
$V_O = V_{CC} + 0.5V$	+20 mA
DC Output Voltage (V_O)	-0.5V to $V_{CC} + 0.5V$
DC Output Source or Sink Current (I_O)	±50 mA
DC V_{CC} or Ground Current per Output Pin (I_{CC} or I_{GND})	±50 mA
Storage Temperature (T_{STG})	-65°C to +150°C
DC Latch-Up	

Source or Sink Current	±300 mA
Junction Temperature (T_J)	
CDIP	175°C

Recommended Operating Conditions

Free Air Ambient Temperature	
Military	-55°C to +125°C
Supply Voltage	
Military	+4.5V to +5.5V
Minimum Input Edge Rate	($\Delta V/\Delta t$)
'ACTQ Devices	125 mV/ns
V_{IN} from 0.8 to 2.0V	
V_{CC} 4.5V, 5.5V	

Note 1: Absolute maximum ratings are values beyond which the device may be damaged or have its useful life impaired. Functional operation under these conditions is not implied.

Note 2: Either voltage limit or current limit is sufficient to protect inputs.

DC Electrical Characteristics for 'ACTQ Family Devices

Symbol	Parameter	V_{CC} (V)	54ACTQ		Units	Conditions
			$T_A =$ -55°C to +125°C			
			Guaranteed Limits			
V_{IH}	Minimum High Level Input Voltage	4.5	2.0		V	$V_{OUT} = 0.1V$ or $V_{CC} - 0.1V$
		5.5	2.0			
V_{IL}	Maximum Low Level Input Voltage	4.5	0.8		V	$V_{OUT} = 0.1V$ or $V_{CC} - 0.1V$
		5.5	0.8			
V_{OH}	Minimum High Level Output Voltage	4.5	4.4		V	$I_{OUT} = -50 \mu A$
		5.5	5.4			
		4.5	3.70		V	(Note 3) $V_{IN} = V_{IL}$ or V_{IH} $I_{OH} = -24 mA$ $I_{OH} = -24 mA$
		5.5	4.70			
V_{OL}	Maximum Low Level Output Voltage	4.5	0.1		V	$I_{OUT} = 50 \mu A$
		5.5	0.1			
		4.5	0.50		V	(Note 3) $V_{IN} = V_{IL}$ or V_{IH} $I_{OL} = 24 mA$ $I_{OL} = 24 mA$
		5.5	0.50			
I_{IN}	Maximum Input Leakage Current	5.5	±1.0		μA	$V_I = V_{CC}, GND$
I_{OZ}	TRI-STATE Output Leakage Current, High or Low	5.5	±10.0		μA	$\overline{OE} = 2.0V$
I_{CCT}	Maximum $I_{CC}/$ Input	5.5	1.6		mA	$V_I = V_{CC} - 2.1V$
I_{OLD}	Minimum Dynamic	5.5	50		mA	$V_{OLD} = 1.65V$ Max
I_{OHD}	Output Current (Note 4)	5.5	-50		mA	$V_{OHD} = 3.85V$ Min
I_{CC}	Maximum Quiescent Supply Current	5.5	160.0		μA	$V_{IN} = V_{CC}$ or GND (Note 4)

DC Electrical Characteristics for 'ACTQ Family Devices (Continued)

Symbol	Parameter	V _{CC} (V)	54ACTQ		Units	Conditions
			T _A = -55°C to +125°C			
			Guaranteed Limits			
V _{OLP}	Quiet Output Maximum Dynamic V _{OL}	5.0	1.5		V	(Note 4)
V _{OLV}	Quiet Output Minimum Dynamic V _{OL}	5.0	-1.2		V	(Note 5)

Note 3: All outputs loaded; thresholds on input associated with output under test.

Note 4: Maximum test duration 2.0 ms, one output loaded at a time.

Note 5: Max number of outputs defined as (n). Data inputs are 0V to 3V. One output @ GND.

AC Electrical Characteristics

Symbol	Parameter	54ACTQ		Units	Fig. No.
		T _A = -55°C to +125°C V _{CC} = 4.5V-5.5V C _L = 50 pF			
		Min	Max		
t _{PLH}	Propagation Delay	2.0	9.0	ns	
t _{PHL}	Data to Outputs	2.0	9.0		
t _{PZH}	Output Enable Time	1.5	9.5	ns	
t _{PZL}		1.5	11.5		
t _{PHZ}	Output Disable Time	1.5	9.5	ns	
t _{PLZ}		1.5	9.5		

Capacitance

Symbol	Parameter	Max	Units	Conditions T _A = 25°C
C _{IN}	Input Capacitance	12.0	pF	V _{CC} = 0.0V
C _{OUT} (Note 6)	Output Capacitance	15.0	pF	V _{CC} = 5.0V

Note 6: C_{OUT} is measured at frequency of f = 1 MHz, per MIL-STD-883B, Method 3012.

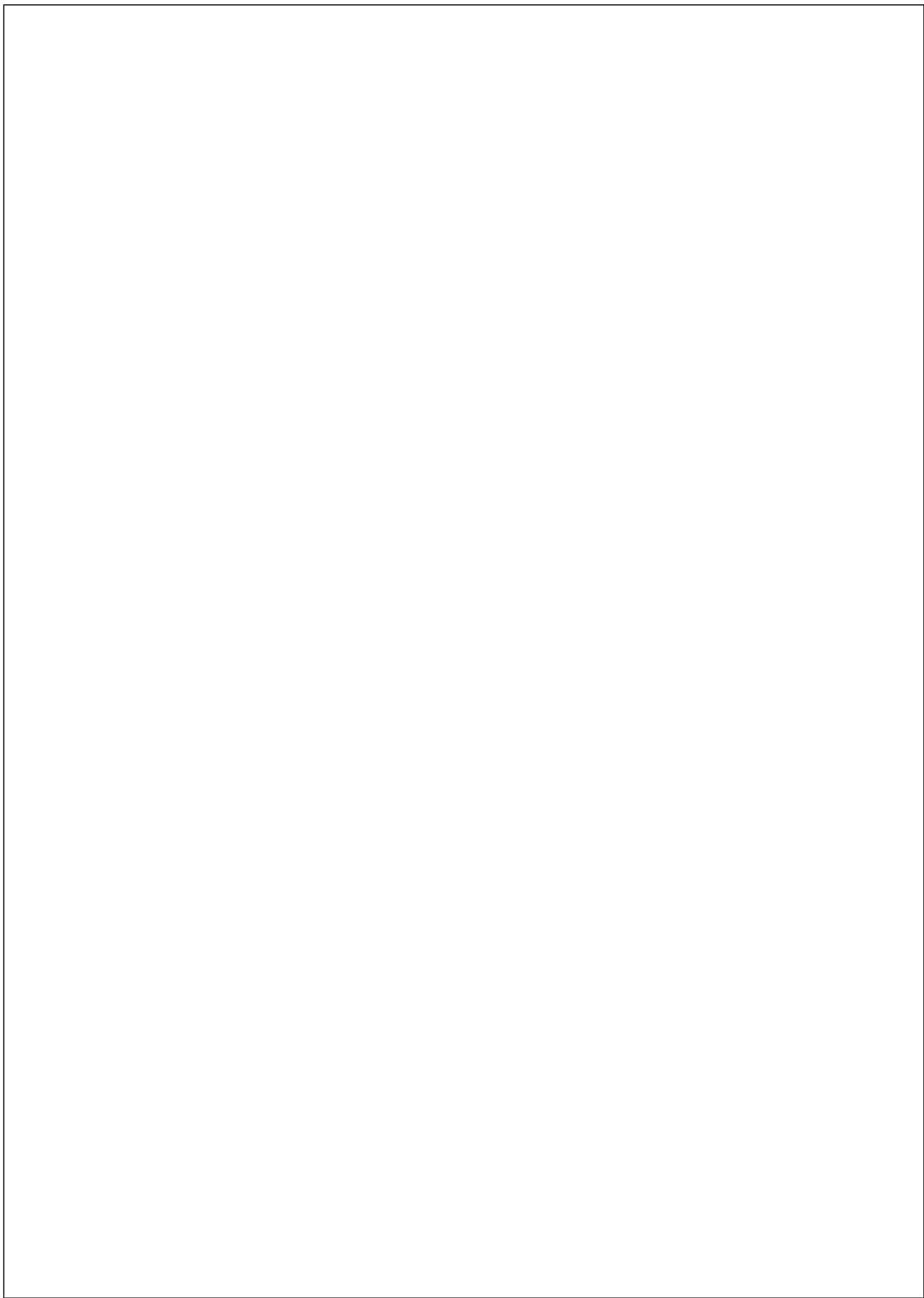

Physical Dimensions inches (millimeters) unless otherwise noted

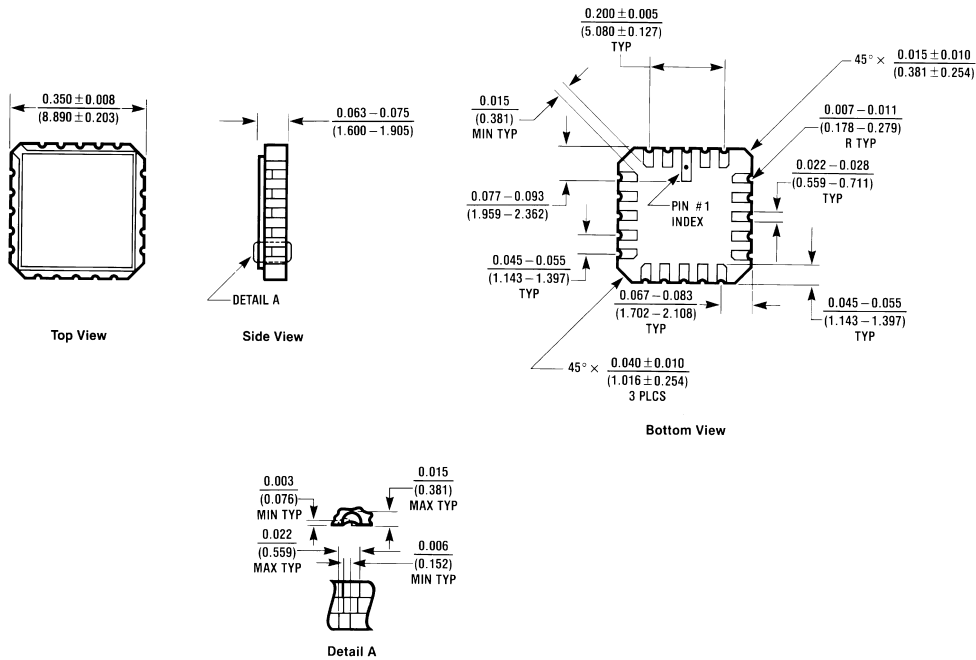

E20A (REV D)

20-Terminal Ceramic Chip Carrier
NS Package Number E20A

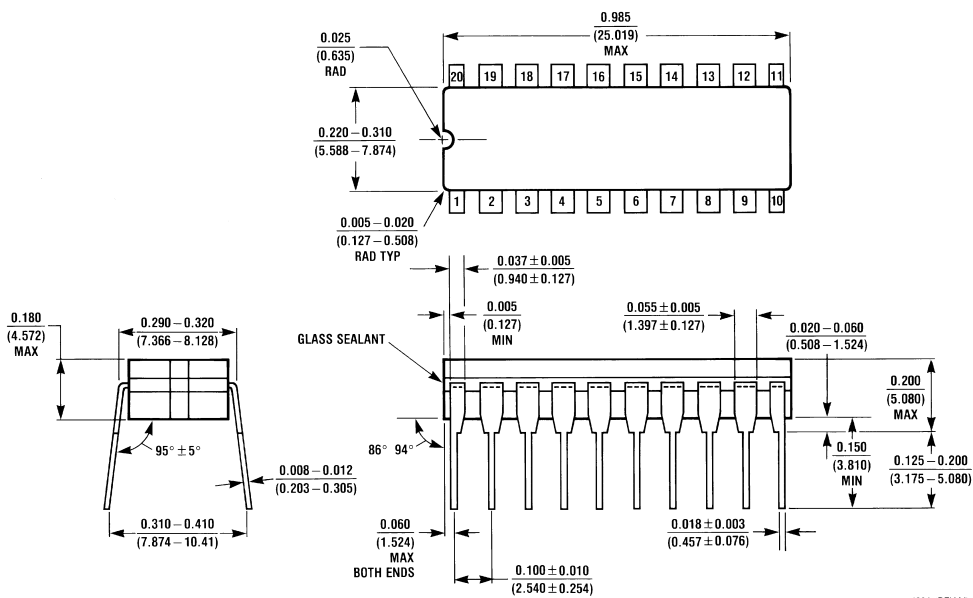

J20A (REV M)

20-Lead Ceramic Dual-In-Line Package
NS Package Number J20A

Physical Dimensions inches (millimeters) unless otherwise noted (Continued)

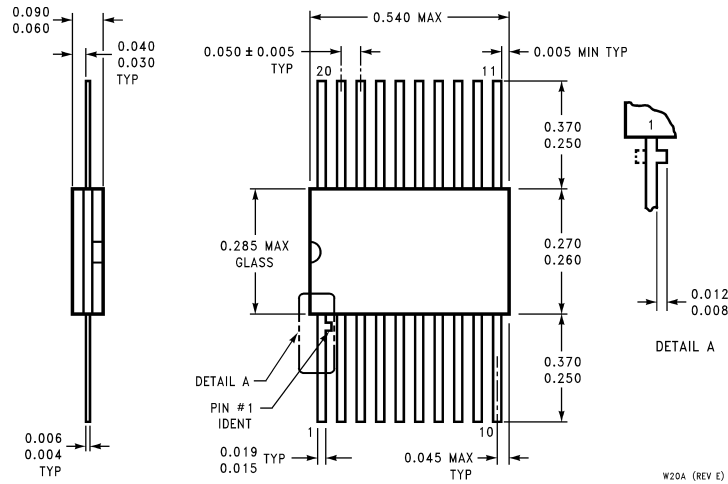

**20-Lead Ceramic Flatpack
NS Package Number W20A**

LIFE SUPPORT POLICY

NATIONAL'S PRODUCTS ARE NOT AUTHORIZED FOR USE AS CRITICAL COMPONENTS IN LIFE SUPPORT DEVICES OR SYSTEMS WITHOUT THE EXPRESS WRITTEN APPROVAL OF THE PRESIDENT OF NATIONAL SEMICONDUCTOR CORPORATION. As used herein:

1. Life support devices or systems are devices or systems which, (a) are intended for surgical implant into the body, or (b) support or sustain life, and whose failure to perform when properly used in accordance with instructions for use provided in the labeling, can be reasonably expected to result in a significant injury to the user.
2. A critical component in any component of a life support device or system whose failure to perform can be reasonably expected to cause the failure of the life support device or system, or to affect its safety or effectiveness.



National Semiconductor Corporation
Americas
Tel: 1-800-272-9959
Fax: 1-800-737-7018
Email: support@nsc.com

www.national.com

National Semiconductor Europe
Fax: +49 (0) 1 80-530 85 86
Email: europe.support@nsc.com
Deutsch Tel: +49 (0) 1 80-530 85 85
English Tel: +49 (0) 1 80-532 78 32
Français Tel: +49 (0) 1 80-532 93 58
Italiano Tel: +49 (0) 1 80-534 16 80

National Semiconductor Asia Pacific Customer Response Group
Tel: 65-2544466
Fax: 65-2504466
Email: sea.support@nsc.com

National Semiconductor Japan Ltd.
Tel: 81-3-5620-6175
Fax: 81-3-5620-6179