

54FCT374

Octal D-Type Flip-Flop with TRI-STATE® Outputs

General Description

The 54FCT374 is an octal D-type flip-flop featuring separate D-type inputs for each flip-flop and TRI-STATE outputs for bus-oriented applications. A buffered Clock (CP) and Output Enable (\overline{OE}) are common to all flip-flops.

Features

- Edge-triggered D-type inputs
- Buffered positive edge-triggered clock
- TRI-STATE outputs for bus-oriented applications
- TTL input and output level compatible
- Low CMOS power consumption
- Output sink capability of 32 mA, source capability of 12 mA
- Standard Microcircuit Drawing (SMD) 5962-9314901

Ordering Code

Military	Package Number	Package Description
54FCT374DMQB	J20A	20-Lead Ceramic Dual-In-Line
54FCT374FMQB	W20A	20-Lead Cerpack
54FCT374LMQB	E20A	20-Lead Ceramic Leadless Chip Carrier, Type C

Connection Diagrams

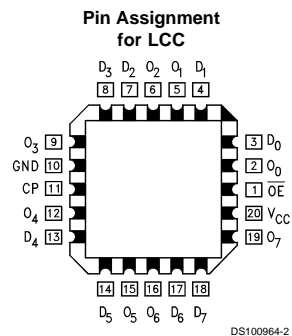
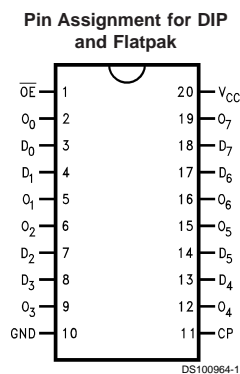

TRI-STATE® is a registered trademark of National Semiconductor Corporation.

Pin Descriptions

Pin Names	Description
D ₀ -D ₇	Data Inputs
CP	Clock Pulse Input (Active Rising Edge)
\overline{OE}	TRI-STATE Output Enable Input (Active LOW)
O ₀ -O ₇	TRI-STATE Outputs

Functional Description

The 'FCT374 consists of eight edge-triggered flip-flops with individual D-type inputs and TRI-STATE true outputs. The buffered clock and buffered Output Enable are common to all flip-flops. The eight flip-flops will store the state of their individual D inputs that meet the setup and hold time requirements on the LOW-to-HIGH Clock (CP) transition. With the Output Enable (\overline{OE}) LOW, the contents of the eight flip-flops are available at the outputs. When \overline{OE} is HIGH, the outputs are in a high impedance state. Operation of the \overline{OE} input does not affect the state of the flip-flops.

Function Table

Inputs			Internal	Outputs	Function
\overline{OE}	CP	D	Q	O	
H	H	L	NC	Z	Hold
H	H	H	NC	Z	Hold
H	N	L	L	Z	Load
H	N	H	H	Z	Load
L	N	L	L	L	Data Available
L	N	H	H	H	Data Available
L	H	L	NC	NC	No Change in Data
L	H	H	NC	NC	No Change in Data

H = HIGH Voltage Level
 L = LOW Voltage Level
 X = Immaterial
 Z = High Impedance
 N = LOW-to-HIGH Transition
 NC = No Change

Logic Diagram

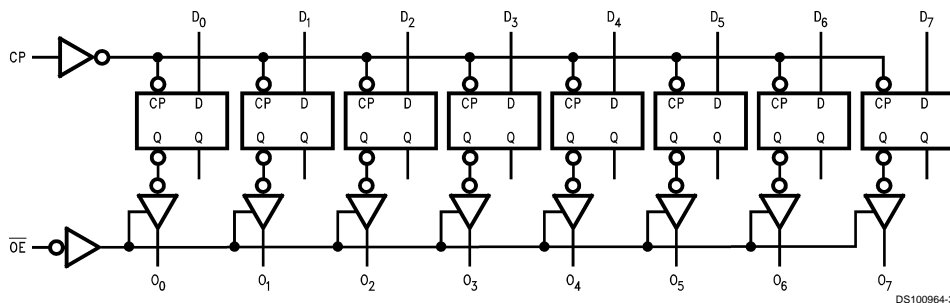

Please note that this diagram is provided only for the understanding of logic operations and should not be used to estimate propagation delays.

Absolute Maximum Ratings (Note 1)

If Military/Aerospace specified devices are required, please contact the National Semiconductor Sales Office/ Distributors for availability and specifications.

Storage Temperature	-65°C to +150°C
Ambient Temperature under Bias	-55°C to +125°C
Junction Temperature under Bias Ceramic	-55°C to +175°C
V _{CC} Pin Potential to Ground Pin	-0.5V to +7.0V
Input Voltage	-0.5V to +7.0V
Input Current	-30 mA to +5.0 mA
Voltage Applied to Any Output in the Disabled or	

Power-Off State in the HIGH State	-0.5V to +5.5V -0.5V to V _{CC}
Current Applied to Output in LOW State (Max)	twice the rated I _{OL} (mA)

Recommended Operating Conditions

Free Air Ambient Temperature Military	-55°C to +125°C
Supply Voltage Military	+4.5V to +5.5V

Note 1: Absolute maximum ratings are values beyond which the device may be damaged or have its useful life impaired. Functional operation under these conditions is not implied.

DC Electrical Characteristics

Symbol	Parameter	FCT374		Units	V _{CC}	Conditions
		Min	Max			
V _{IH}	Input HIGH Voltage	2.0		V		Recognized HIGH Signal
V _{IL}	Input LOW Voltage	0.8		V		Recognized LOW Signal
V _{CD}	Input Clamp Diode Voltage	-1.2		V	Min	I _{IN} = -18 mA
V _{OH}	Output HIGH Voltage	54FCT	4.3	V	Min	I _{OH} = -300 μA
		54FCT	2.4	V	Min	I _{OH} = -12 mA
V _{OL}	Output LOW Voltage	54FCT	0.2	V	Min	I _{OL} = 300 μA
		54FCT	0.5	V	Min	I _{OL} = 32mA
I _{IH}	Input HIGH Current	5		μA	Max	V _{IN} = 2.7V (Note 3) V _{IN} = V _{CC}
I _{IL}	Input LOW Current	-5		μA	Max	V _{IN} = 0.5V (Note 3) V _{IN} = 0.0V
		-5				
I _{OZH}	Output Leakage Current	10		μA	0 – 5.5V	V _{OUT} = 2.7V; \overline{OE} = 2.0V
I _{OZL}	Output Leakage Current	-10		μA	0 – 5.5V	V _{OUT} = 0.5V; \overline{OE} = 2.0V
I _{OS}	Output Short-Circuit Current	-60		mA	Max	V _{OUT} = 0.0V
I _{CCQ}	Power Supply Current	1.5		mA	Max	V _{IN} = 0.2V or V _{IN} = 5.3V, f _I = 0MHz
ΔI _{CC}	Power Supply Current	2.0		mA	Max	V _{IN} = 3.4V
I _{CC1}	Additional I _{CC} /Input	6.0		mA	Max	V _I = V _{CC} - 2.1V or V _{IN} = GND, f _{CP} = 10MHz, Outputs open, \overline{OE} = GND, one bit toggling at f _I = 5MHz, 50% duty cycle
		5.5		mA	Max	V _I = 5.3V or V _{CC} = 0.2V, f _{CP} = 10MHz, Outputs open, \overline{OE} = GND, one bit toggling at f _I = 5MHz, 50% duty cycle
I _{CCD}	Dynamic I _{CC} No Load	0.4		mA/ MHz	Max	Outputs Open, \overline{OE} = GND, One bit toggling, 50% duty cycle, V _{IN} = 5.3V or V _{IN} = 0.2V

Note 2: For 8-bit toggling, I_{CCD} < 0.8 mA/MHz.

Note 3: Guaranteed, but not tested.

AC Electrical Characteristics				
Symbol	Parameter	54FCT		Units
		T _A = -55°C to +125°C V _{CC} = 4.5V to 5.5V C _L = 50 pF		
		Min	Max	
t _{PLH}	Propagation Delay	2.0	11.0	ns
t _{PHL}	CP to O _n	2.0	11.0	
t _{PZH}	Output Enable Time	1.5	14.0	ns
t _{PZL}		1.5	14.0	
t _{PHZ}	Output Disable Time	1.5	8.0	ns
t _{PLZ}		1.5	8.0	

AC Operating Requirements				
Symbol	Parameter	54FCT		Units
		T _A = -55°C to +125°C V _{CC} = 4.5V to 5.5V C _L = 50 pF		
		Min	Max	
t _s (H)	Setup Time, HIGH	2.5		ns
t _s (L)	or LOW D _n to CP	2.5		
t _h (H)	Hold Time, HIGH	2.5		ns
t _h (L)	or LOW D _n to CP	2.5		
t _w (H)	Pulse Width, CP	7.0		ns
t _w (L)	HIGH or LOW	7.0		

Capacitance				
Symbol	Parameter	Typ	Units	Conditions (T _A = 25°C)
C _{IN}	Input Capacitance	5.0	pF	V _{CC} = 0V
C _{OUT} (Note 4)	Output Capacitance	9.0	pF	V _{CC} = 5.0V

Note 4: C_{OUT} is measured at frequency f = 1 MHz, per MIL-STD-883B, Method 3012.

Capacitance (Continued)

AC Loading

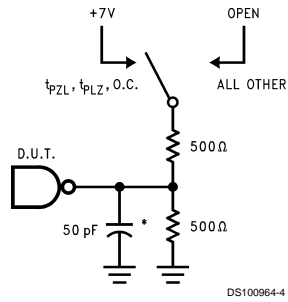

*Includes jig and probe capacitance

FIGURE 1. Standard AC Test Load

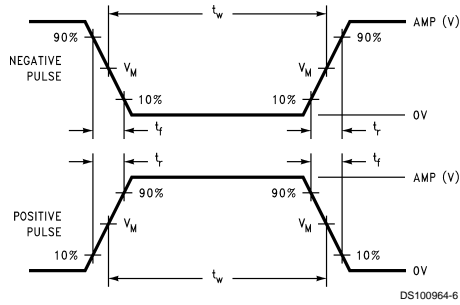

FIGURE 2. $V_M = 1.5V$

Input Pulse Requirements

Amplitude	Rep. Rate	t_w	t_r	t_f
3.0V	1 MHz	500 ns	2.5 ns	2.5 ns

FIGURE 3. Test Input Signal Requirements

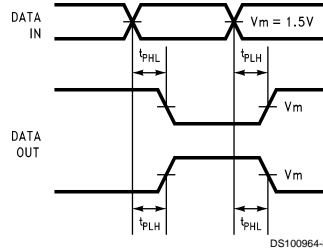

FIGURE 4. Propagation Delay Waveforms for Inverting and Non-Inverting Functions

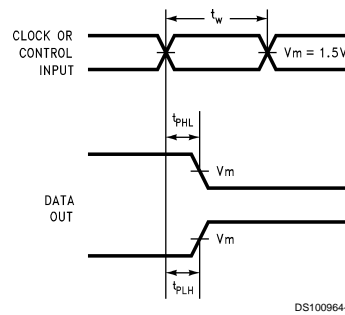

FIGURE 5. Propagation Delay, Pulse Width Waveforms

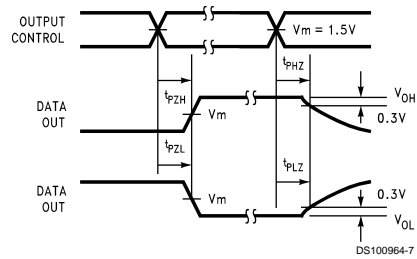

FIGURE 6. TRI-STATE Output HIGH and LOW Enable and Disable Times

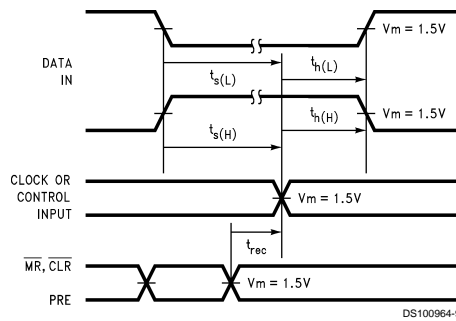
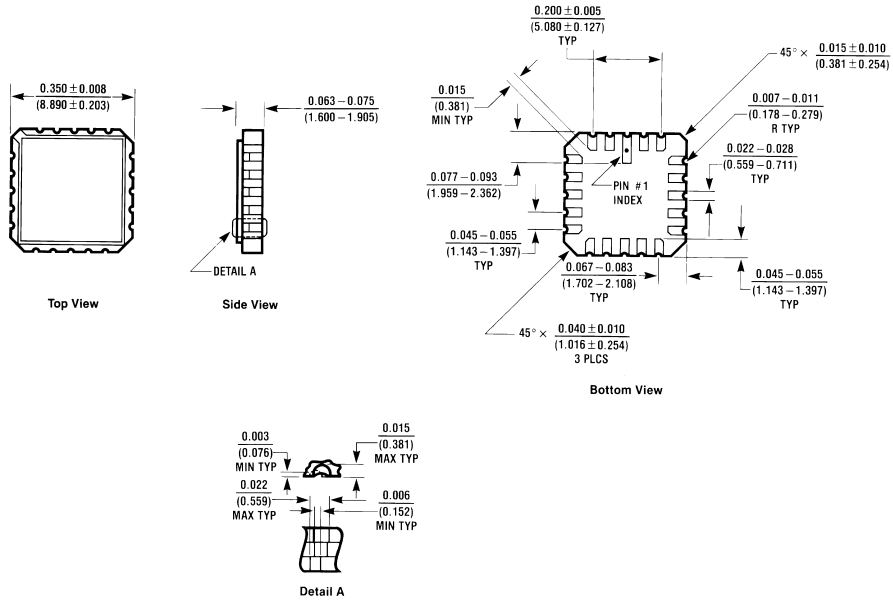
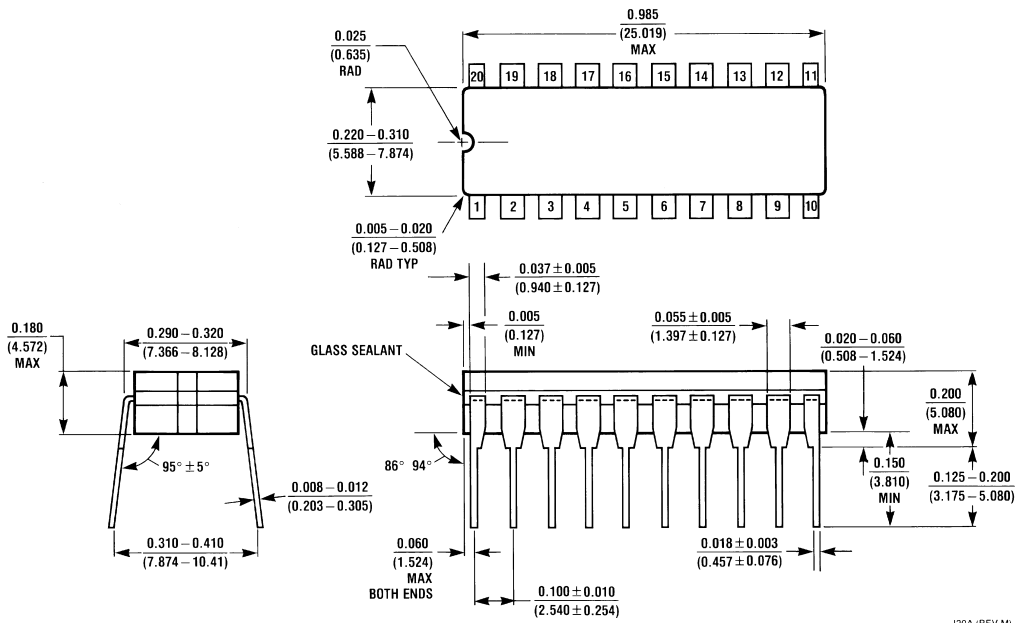

FIGURE 7. Setup Time, Hold Time and Recovery Time Waveforms

Physical Dimensions inches (millimeters) unless otherwise noted



20-Terminal Ceramic Chip Carrier (L)
NS Package Number E20A



20-Lead Ceramic Dual-In-Line (D)
NS Package Number J20A

Physical Dimensions inches (millimeters) unless otherwise noted (Continued)

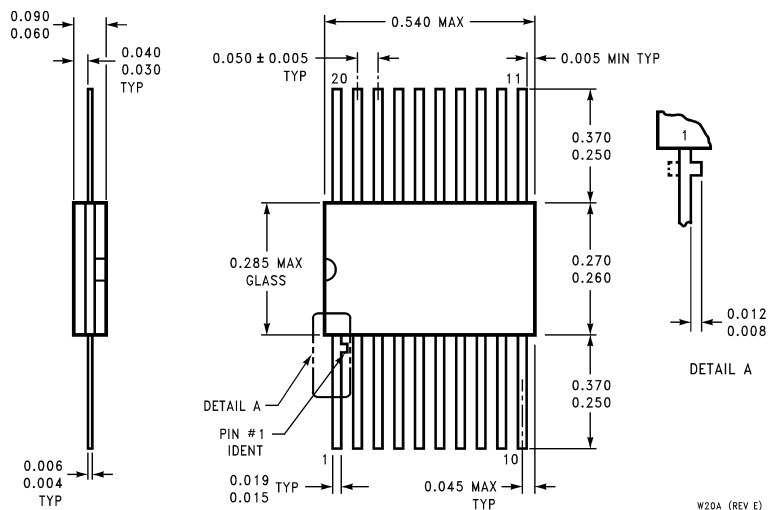

LIFE SUPPORT POLICY

NATIONAL'S PRODUCTS ARE NOT AUTHORIZED FOR USE AS CRITICAL COMPONENTS IN LIFE SUPPORT DEVICES OR SYSTEMS WITHOUT THE EXPRESS WRITTEN APPROVAL OF THE PRESIDENT AND GENERAL COUNSEL OF NATIONAL SEMICONDUCTOR CORPORATION. As used herein:

1. Life support devices or systems are devices or systems which, (a) are intended for surgical implant into the body, or (b) support or sustain life, and whose failure to perform when properly used in accordance with instructions for use provided in the labeling, can be reasonably expected to result in a significant injury to the user.
2. A critical component is any component of a life support device or system whose failure to perform can be reasonably expected to cause the failure of the life support device or system, or to affect its safety or effectiveness.



National Semiconductor Corporation
Americas
Tel: 1-800-272-9959
Fax: 1-800-737-7018
Email: support@nsc.com

National Semiconductor Europe
Fax: +49 (0) 1 80-530 85 86
Email: europe.support@nsc.com
Deutsch Tel: +49 (0) 1 80-530 85 85
English Tel: +49 (0) 1 80-532 78 32
Français Tel: +49 (0) 1 80-532 93 58
Italiano Tel: +49 (0) 1 80-534 16 80

National Semiconductor Asia Pacific Customer Response Group
Tel: 65-2544466
Fax: 65-2504466
Email: sea.support@nsc.com

National Semiconductor Japan Ltd.
Tel: 81-3-5639-7560
Fax: 81-3-5639-7507

www.national.com