

DS3658 Quad High Current Peripheral Driver

General Description

The DS3658 quad peripheral driver is designed for those applications where low operating power, high breakdown voltage, high output current and low output ON voltage are required. A unique input circuit combines TTL compatibility with high impedance. In fact, its extreme low input current allows it to be driven directly by a CMOS device.

The outputs are capable of sinking 600 mA each and offer a 70V breakdown. However, for inductive loads the output should be clamped to 35V or less to avoid latch-up during turn off (inductive fly back protection—refer AN-213). An on-chip clamp diode capable of handling 800 mA is provided at each output for this purpose. In addition, the DS3658 incorporates circuitry that guarantees glitch-free power up or down operation and a fail-safe feature which puts the output in a high impedance state when the input is open.

The molded package is specifically constructed to allow increased power dissipation over conventional packages. The four ground pins are directly connected to the device chip with a special copper lead frame. When the quad driver is soldered into a PC board, the power rating of the device improves significantly.

Applications

- Relay drivers
- Lamp drivers
- Solenoid drivers
- Hammer drivers
- Stepping motor drivers
- Triac drivers

- LED drivers
- High current, high voltage drivers
- Level translators
- Fiber optic LED drivers

Features

- Single saturated transistor outputs
- Low standby power, 10 mW typical
- High impedance TTL compatible inputs
- Outputs may be tied together for increased current capacity
- High output current
600 mA per output
2.4A per package
- No output latch-up at 35V
- Low output ON voltage (350 mV typ @ 600 mA)
- High breakdown voltage (70V)
- Open collector outputs
- Output clamp diodes for inductive fly back protection
- NPN inputs for minimal input currents (1 μ A typical)
- Low operating power
- Standard 5V power supply
- Power up/down protection
- Fail safe operation
- 2W power package
- Pin-for-pin compatible with SN75437

Connection Diagram

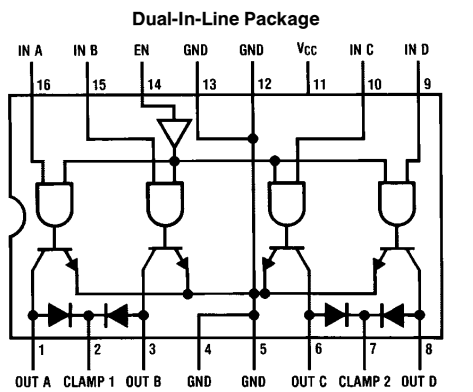

Top View

Order Number DS3658N
See NS Package Number N16E

Truth Table

IN	EN	OUT
H	H	L
L	H	Z
H	L	Z
L	L	Z

H = High state
L = Low state
Z = High impedance state

Absolute Maximum Ratings (Note 1)

If Military/Aerospace specified devices are required, please contact the National Semiconductor Sales Office/Distributors for availability and specifications.

Supply Voltage	7V
Input Voltage	15V
Output Voltage	70V
Output Current	1.5A
Continuous Power Dissipation @ 25°C Free-Air (Note 5)	2075 mW
Storage Temperature Range	-65°C to +150°C
Lead Temperature (Soldering, 4 sec.)	260°C

Operating Conditions

	Min	Max	Units
Supply Voltage	4.75	5.25	V
Ambient Temperature	0	70	°C

Electrical Characteristics (Notes 2 and 3)

Symbol	Parameter	Conditions	Min	Typ	Max	Units
V _{IH}	Input High Voltage		2.0			V
V _{IL}	Input Low Voltage				0.8	V
I _{IH}	Input High Current	V _{IN} = 5.25V, V _{CC} = 5.25V		1.0	10	μA
I _{IL}	Input Low Current	V _{IN} = 0.4V			±10	μA
V _{IK}	Input Clamp Voltage	I _I = -12 mA		-0.8	-1.5	V
V _{OL}	Output Low Voltage	I _L = 300 mA		0.2	0.4	V
		I _L = 600 mA (Note 4)		0.35	0.7	V
I _{CEX}	Output Leakage Current	V _{CE} = 70V, V _{IN} = 0.8V			100	μA
V _F	Diode Forward Voltage	I _F = 800 mA		1.0	1.6	V
I _R	Diode Leakage Current	V _R = 70V			100	μA
I _{CC}	Supply Current	All Inputs High		60	85	mA
		All Inputs Low		2	4	mA

Switching Characteristics (Note 2)

Symbol	Parameter	Conditions	Min	Typ	Max	Units
t _{PHL}	Turn On Delay	R _L = 60Ω, V _L = 30V		226	500	ns
t _{PLH}	Turn Off Delay	R _L = 60Ω, V _L = 30V		2430	8000	ns

Note 1: "Absolute Maximum Ratings" are those values beyond which the safety of the device cannot be guaranteed. They are not meant to imply that the device should be operated at these limits. The table of "Electrical Characteristics" provides conditions for actual device operation.

Note 2: Unless otherwise specified, min/max limits apply across the 0°C to +70°C temperature range and the 4.75V to 5.25V power supply range. All typical values are for T_A = 25°C and V_{CC} = 5.0V.

Note 3: All currents into device pins are shown as positive; all currents out of device pins are shown as negative; all voltages are referenced to ground, unless otherwise specified. All values shown as max or min are so classified on absolute value basis.

Note 4: All sections of this quad circuit may conduct rated current simultaneously; however, power dissipation averaged over a short interval of time must fall within specified continuous dissipation ratings.

Note 5: For operation over 25°C free-air temperature, derate linearly to 1328 mW @ 70°C @ the rate of 16.6 mW/°C.

AC Test Circuit

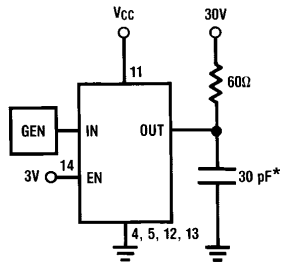

TL/F/5819-2

*Includes probe and jig capacitance

Switching Waveforms

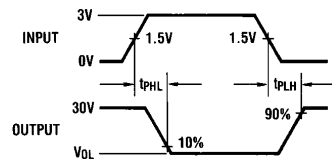

TL/F/5819-3

Typical Applications

Stepping Motor Driver

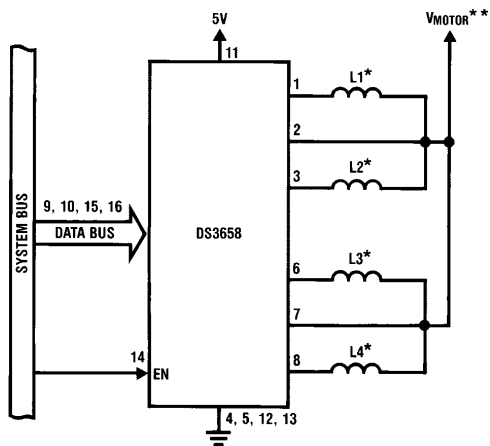

TL/F/5819-4

*L1, L2, L3, L4 are the windings of a bifilar stepping motor

**VMOTOR is the supply voltage of the motor

Lamp Driver

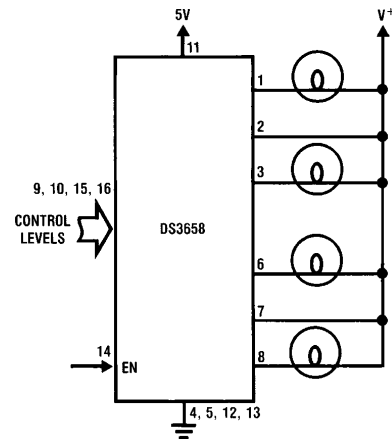

TL/F/5819-5

Physical Dimensions inches (millimeters)

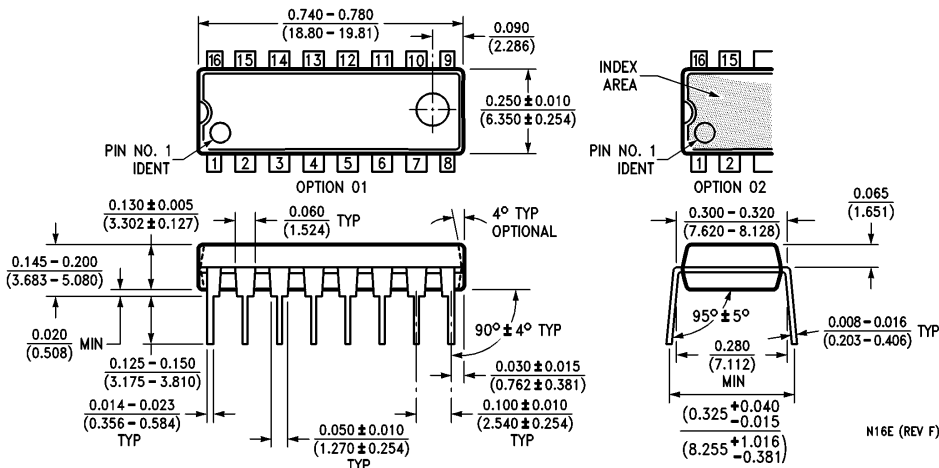

Molded Dual-In-Line Package (N)
Order Number DS3658N
NS Package Number N16E

LIFE SUPPORT POLICY

NATIONAL'S PRODUCTS ARE NOT AUTHORIZED FOR USE AS CRITICAL COMPONENTS IN LIFE SUPPORT DEVICES OR SYSTEMS WITHOUT THE EXPRESS WRITTEN APPROVAL OF THE PRESIDENT OF NATIONAL SEMICONDUCTOR CORPORATION. As used herein:

1. Life support devices or systems are devices or systems which, (a) are intended for surgical implant into the body, or (b) support or sustain life, and whose failure to perform, when properly used in accordance with instructions for use provided in the labeling, can be reasonably expected to result in a significant injury to the user.
2. A critical component is any component of a life support device or system whose failure to perform can be reasonably expected to cause the failure of the life support device or system, or to affect its safety or effectiveness.



National Semiconductor Corporation
 1111 West Bardin Road
 Arlington, TX 76017
 Tel: 1(800) 272-9959
 Fax: 1(800) 737-7018

National Semiconductor Europe
 Fax: (+49) 0-180-530 85 86
 Email: cnjwge@tevm2.nsc.com
 Deutsch Tel: (+49) 0-180-530 85 85
 English Tel: (+49) 0-180-532 78 32
 Français Tel: (+49) 0-180-532 93 58
 Italiano Tel: (+49) 0-180-534 16 80

National Semiconductor Hong Kong Ltd.
 19th Floor, Straight Block,
 Ocean Centre, 5 Canton Rd.
 Tsimshatsui, Kowloon
 Hong Kong
 Tel: (852) 2737-1600
 Fax: (852) 2736-9960

National Semiconductor Japan Ltd.
 Tel: 81-043-299-2309
 Fax: 81-043-299-2408

National does not assume any responsibility for use of any circuitry described, no circuit patent licenses are implied and National reserves the right at any time without notice to change said circuitry and specifications.