

DS36954 Quad Differential Bus Transceiver

General Description

The DS36954 is a low power, quad EIA-485 differential bus transceiver especially suited for high speed, parallel, multi-point, I/O bus applications. A compact 20-pin surface mount PLCC or SOIC package provides high transceiver integration and a very small PC board footprint.

Propagation delay skew between devices is specified to aid in parallel interface designs — limits on maximum and minimum delay times are guaranteed.

Five devices can implement a complete SCSI initiator or target interface. Three transceivers in a package are pinned out

for data bus connections. The fourth transceiver, with the flexibility provided by its individual enables, can serve as a control bus transceiver.

Features

- Pinout for SCSI interface
- Compact 20-pin PLCC or SOIC package
- Meets EIA-485 standard for multipoint bus transmission
- Greater than 60 mA source/sink currents
- Thermal shutdown protection
- Glitch-free driver outputs on power up and down

Connection Diagrams

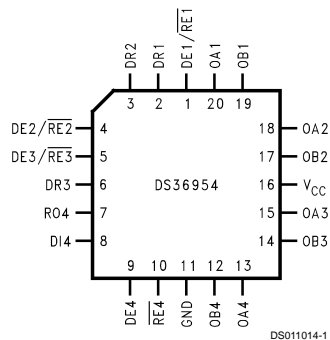

Order Number DS36954V
See NS Package Number V20A

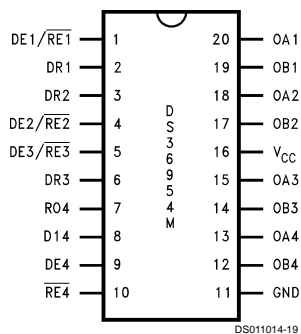

Order Number DS36954M
See NS Package Number M20B

Logic Diagrams

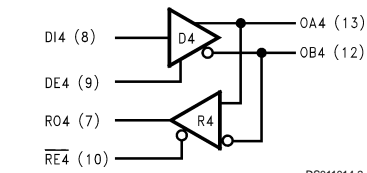
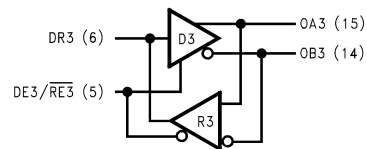
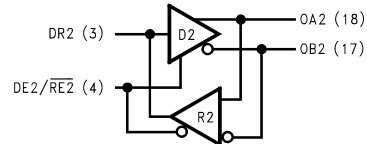
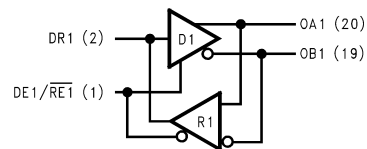

TRI-STATE® is a registered trademark of National Semiconductor Corporation.

Absolute Maximum Ratings (Note 1)

If Military/Aerospace specified devices are required, please contact the National Semiconductor Sales Office/Distributors for availability and specifications.

Supply Voltage	7V
Control Input Voltage	$V_{CC} + 0.5V$
Driver Input Voltage	$V_{CC} + 0.5V$
Driver Output Voltage/	
Receiver Input Voltage	-10V to +15V
Receiver Output Voltage	5.5V
Continuous Power Dissipation @ +25°C	
V Package	1.73W
M Package	1.73W
Derate V Package	13.9 mW/°C above +25°C

Derate M Package	13.7 mW/°C above +25°C
Storage Temperature Range	-65°C to +150°C
Lead Temperature (Soldering 4 Sec.)	260°C

Recommended Operating Conditions

	Min	Max	Units
Supply Voltage, V_{CC}	4.75	5.25	V
Bus Voltage	-7	+12	V
Operating Free Air Temperature (T_A)	0	+70	°C

Electrical Characteristics (Note 2)

Over Supply Voltage and Operating Temperature ranges, unless otherwise specified

Symbol	Parameter	Conditions	Min	Typ	Max	Units
DRIVER CHARACTERISTICS						
V_{ODL}	Differential Driver Output Voltage (Full Load)	$I_L = 60 \text{ mA}$ $V_{CM} = 0V$	1.5	1.9		V
V_{OD}	Differential Driver Output Voltage (Termination Load)	$R_L = 100\Omega$ (EIA-422)	2.0	2.25		V
		$R_L = 54\Omega$ (EIA-485)	1.5	2.0		V
ΔV_{ODI}	Change in Magnitude of Driver Differential Output Voltage for Complementary Output States	$R_L = 54$ or 100Ω (Note 4) (Figure 1) (EIA-422/485)			0.2	V
V_{OC}	Driver Common Mode Output Voltage (Note 5)	$R_L = 54\Omega$ (Figure 1) (EIA-485)			3.0	V
ΔV_{OCI}	Change in Magnitude of Common Mode Output Voltage	(Note 4) (Figure 1) (EIA-422/485)			0.2	V
V_{OH}	Output Voltage High	$I_{OH} = -55 \text{ mA}$	2.7	3.2		V
V_{OL}	Output Voltage Low	$I_{OL} = 55 \text{ mA}$		1.4	1.7	V
V_{IH}	Input Voltage High		2.0			V
V_{IL}	Input Voltage Low				0.8	V
V_{CL}	Input Clamp Voltage	$I_{CL} = -18 \text{ mA}$			-1.5	V
I_{IH}	Input High Current	$V_{IN} = 2.4V$ (Note 3)			20	μA
I_{IL}	Input Low Current	$V_{IN} = 0.4V$ (Note 3)			-20	μA
I_{OSC}	Driver Short-Circuit Output Current (Note 9)	$V_O = -7V$ (EIA-485)		-130	-250	mA
		$V_O = 0V$ (EIA-422)		-90	-150	mA
		$V_O = +12V$ (EIA-485)		130	250	mA
RECEIVER CHARACTERISTICS						
I_{OSR}	Short Circuit Output Current	$V_O = 0V$ (Note 9)	-15	-28	-75	mA
I_{OZ}	TRI-STATE® Output Current	$V_O = 0.4V$ to $2.4V$			20	μA
V_{OH}	Output Voltage High	$V_{ID} = 0.2V$, $I_{OH} = 0.4 \text{ mA}$	2.4	3.0		V
V_{OL}	Output Voltage Low	$V_{ID} = -0.2V$, $I_{OL} = 4 \text{ mA}$		0.35	0.5	V
V_{TH}	Differential Input High Threshold Voltage	$V_O = V_{OH}$, $I_O = -0.4 \text{ mA}$ (EIA-422/485)		0.03	0.2	V
V_{TL}	Differential Input Low Threshold Voltage (Note 6)	$V_O = V_{OL}$, $I_O = 4.0 \text{ mA}$ (EIA-422/485)	-0.20	-0.03		V
V_{HST}	Hysteresis (Note 7)	$V_{CM} = 0V$	35	60		mV
DRIVER AND RECEIVER CHARACTERISTICS						
V_{IH}	Enable Input Voltage High		2.0			V
V_{IL}	Enable Input Voltage Low				0.8	V

Electrical Characteristics (Note 2) (Continued)

Over Supply Voltage and Operating Temperature ranges, unless otherwise specified

Symbol	Parameter	Conditions	Min	Typ	Max	Units
DRIVER AND RECEIVER CHARACTERISTICS						
V_{CL}	Enable Input Clamp Voltage	$I_{CL} = -18 \text{ mA}$			-1.5	V
I_{IN}	Line Input Current (Note 8)	Other Input = 0V DE/ \overline{RE} = 0.8V DE4 = 0.8V	$V_I = +12\text{V}$	0.5	1.0	mA
			$V_I = -7\text{V}$	-0.45	-0.8	mA
I_{ING}	Line Input Current (Note 8)	Other Input = 0V DE/ \overline{RE} and DE4 = 2V $V_{CC} = 3.0\text{V}$ $T_A = +25^\circ\text{C}$	$V_I = +12\text{V}$		1.0	mA
			$V_I = -7\text{V}$		-0.8	mA
I_{IH}	Enable Input Current High	$V_{IN} = 2.4\text{V}$ DE/ \overline{RE}	$V_{CC} = 3.0\text{V}$	1	40	μA
			$V_{CC} = 4.75\text{V}$	1		μA
			$V_{CC} = 5.25\text{V}$	1	40	μA
			$V_{CC} = 3.0\text{V}$	1	20	μA
I_{IL}	Enable Input Current Low	$V_{IN} = 0.8\text{V}$ DE/ \overline{RE}	$V_{CC} = 3.0\text{V}$	-6	-40	μA
			$V_{CC} = 4.75\text{V}$	-12		μA
			$V_{CC} = 5.25\text{V}$	-14	-40	μA
			$V_{CC} = 3.0\text{V}$	-3	-20	μA
I_{CCR}	Supply Current (Note 10)	No Load, DE/ \overline{RE} and DE4 = 2.0V		75	90	mA
				50	70	mA

Switching Characteristics

Over Supply Voltage and Operating Temperature ranges, unless otherwise specified.

Symbol	Parameter	Conditions	Min	Typ	Max	Units	
DRIVER SINGLE-ENDED CHARACTERISTICS							
t_{PZH}	Output Enable Time to High Level	$R_L = 110\Omega$ (Figure 5)		35	40	ns	
t_{PZL}	Output Enable Time to Low Level		(Figure 6)		25	40	ns
t_{PHZ}	Output Disable Time to High Level		(Figure 5)		15	25	ns
t_{PLZ}	Output Disable Time to Low Level		(Figure 6)		35	40	ns
DRIVER DIFFERENTIAL CHARACTERISTICS							
t_r, t_f	Rise and Fall Time	$R_L = 54\Omega$ $C_L = 50 \text{ pF}$ $C_D = 15 \text{ pF}$ (Figures 3, 4, 9)		13	16	ns	
t_{PLHD}	Differential Propagation		9	15	19	ns	
t_{PHLD}	Delays (Note 15)		9	12	19	ns	
t_{SKD}	$ t_{PLHD} - t_{PHLD} $ Diff. Skew		3	6		ns	
RECEIVER CHARACTERISTICS							
t_{PLHD}	Differential Propagation Delays	$C_L = 15 \text{ pF}$ $V_{CM} = 2.0\text{V}$ (Figure 7)	9	14	19	ns	
t_{PHLD}			9	13	19	ns	
t_{SKD}	$ t_{PLHD} - t_{PHLD} $ Diff. Receiver Skew			1	3	ns	
t_{PZH}	Output Enable Time to High Level	$C_L = 15 \text{ pF}$ (Figure 8)		15	22	ns	
t_{PZL}	Output Enable Time to Low Level			20	30	ns	
t_{PHZ}	Output Disable Time from High Level			20	30	ns	
t_{PLZ}	Output Disable Time from Low Level			17	25	ns	

Note 1: "Absolute Maximum Ratings" are those values beyond which the safety of the device cannot be guaranteed. They are not meant to imply that the devices should be operated at these limits. The tables of "Electrical Characteristics" specify conditions for device operation.

Note 2: Current into device pins is defined as positive. Current out of device pins is defined as negative. All voltages are referenced to ground unless otherwise specified.

Note 3: I_{IH} and I_{IL} include driver input current and receiver TRI-STATE leakage current on DR(1-3).

Note 4: $\Delta IVODI$ and $\Delta IVOCI$ are changes in magnitude of V_{OD} and V_{OC} , respectively, that occur when the input changes state.

Switching Characteristics (Continued)

- Note 5:** In EIA Standards EIA-422 and EIA-485, V_{OC} , which is the average of the two output voltages with respect to ground, is called output offset voltage, V_{OS} .
- Note 6:** Threshold parameter limits specified as an algebraic value rather than by magnitude.
- Note 7:** Hysteresis defined as $V_{HST} = V_{TH} - V_{TL}$.
- Note 8:** I_N includes the receiver input current and driver TRI-STATE leakage current.
- Note 9:** Short one output at a time.
- Note 10:** Total package supply current.
- Note 11:** All typicals are given for $V_{CC} = 5.0V$ and $T_A = +25^\circ C$.

Parameter Measurement Information

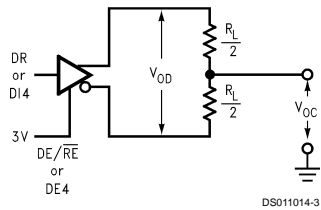

FIGURE 1. Driver V_{OD} and V_{OC} (Note 13)

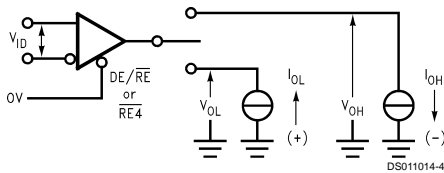

FIGURE 2. Receiver V_{OH} and V_{OL}

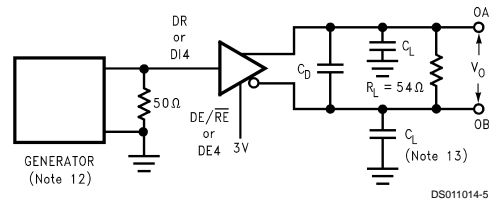

FIGURE 3. Driver Differential Propagation Delay Load Circuit

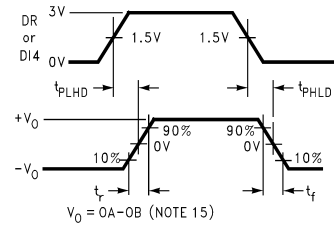
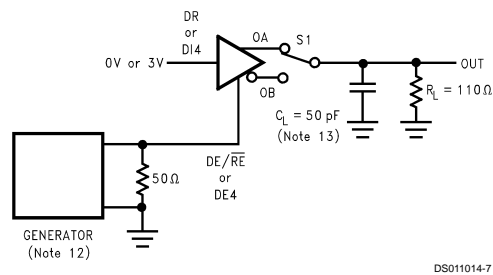

FIGURE 4. Driver Differential Propagation Delays and Transition Times



S1 to OA for DI = 3V
S1 to OB for DI = 0V

FIGURE 5. Driver Enable and Disable Timing (t_{PZH} , t_{PHZ})

Parameter Measurement Information (Continued)

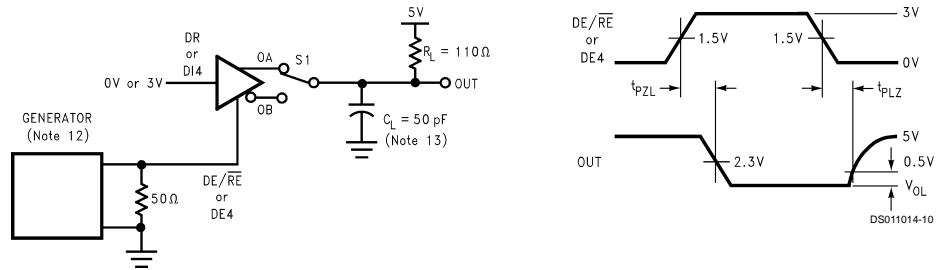

S1 to OA for DI = 0V
S1 to OB for DI = 3V

FIGURE 6. Driver Enable and Disable Timing (t_{PZL} , t_{PLZ})

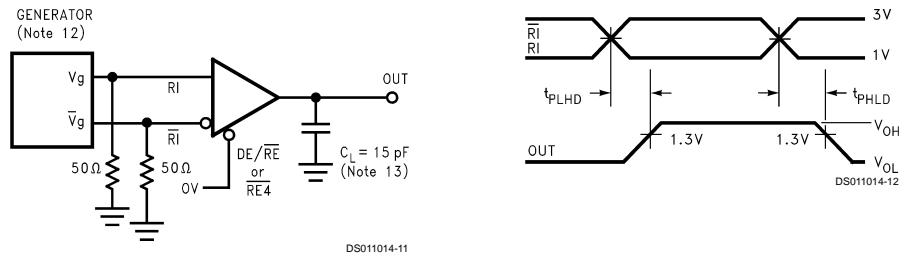

FIGURE 7. Receiver Differential Propagation Delay Timing

Parameter Measurement Information (Continued)

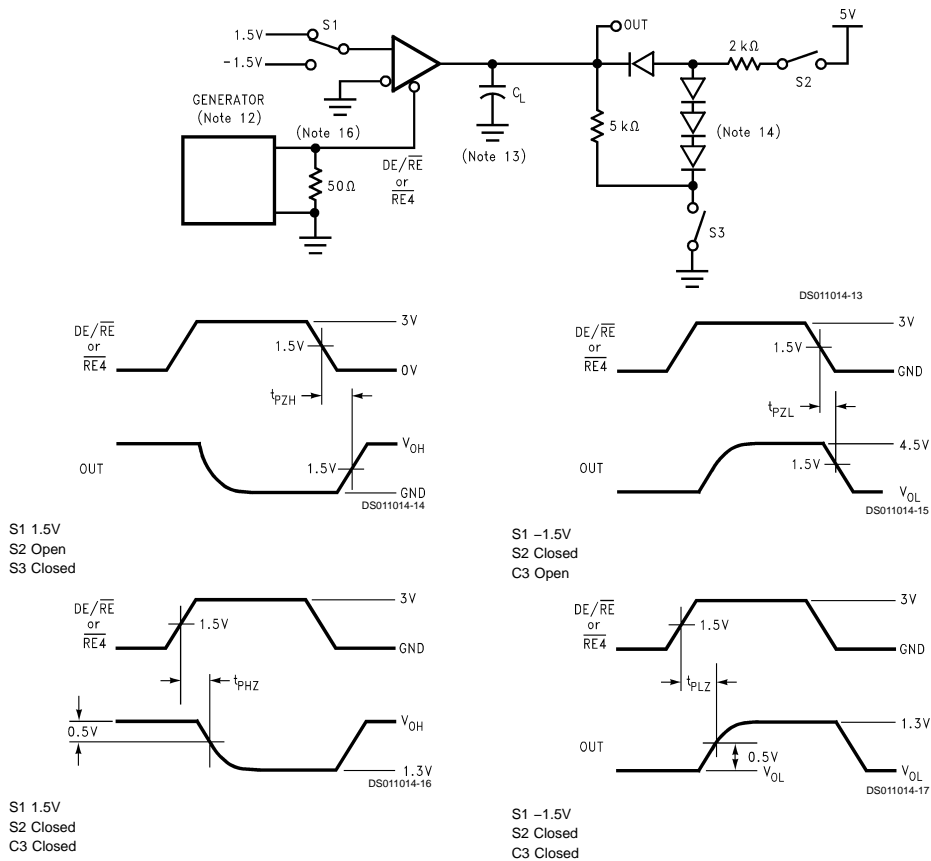
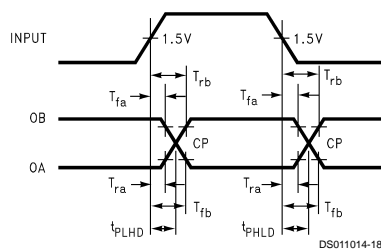

FIGURE 8. Receiver Enable and Disable Timing



$$T_{CP} = \frac{(T_{fb} \times T_{rb}) - (T_{ra} \times T_{fa})}{T_{rb} - T_{ra} - T_{fa} + T_{fb}}$$

T_{ra} , T_{rb} , T_{fa} and T_{fb} are propagation delay measurements to the 20% and 80% levels.

T_{CP} = Crossing Point

FIGURE 9. Propagation Delay Timing for Calculations of Driver Differential Propagation Delays

Note 12: The input pulse is supplied by a generator having the following characteristics: $f = 1.0$ MHz, 50% duty cycle, t_r and $t_f < 6.0$ ns, $Z_O = 50\Omega$.

Note 13: C_L includes probe and stray capacitance.

Note 14: Diodes are 1N916 or equivalent.

Note 15: Differential propagation delays are calculated from single-ended propagation delays measured from driver input to the 20% and 80% levels on the driver outputs (Figure 9).

Parameter Measurement Information (Continued)

Note 16: On transceivers 1–3 the driver is loaded with receiver input conditions when $\overline{DE/\overline{RE}}$ is high. Do not exceed the package power dissipation limit when testing.

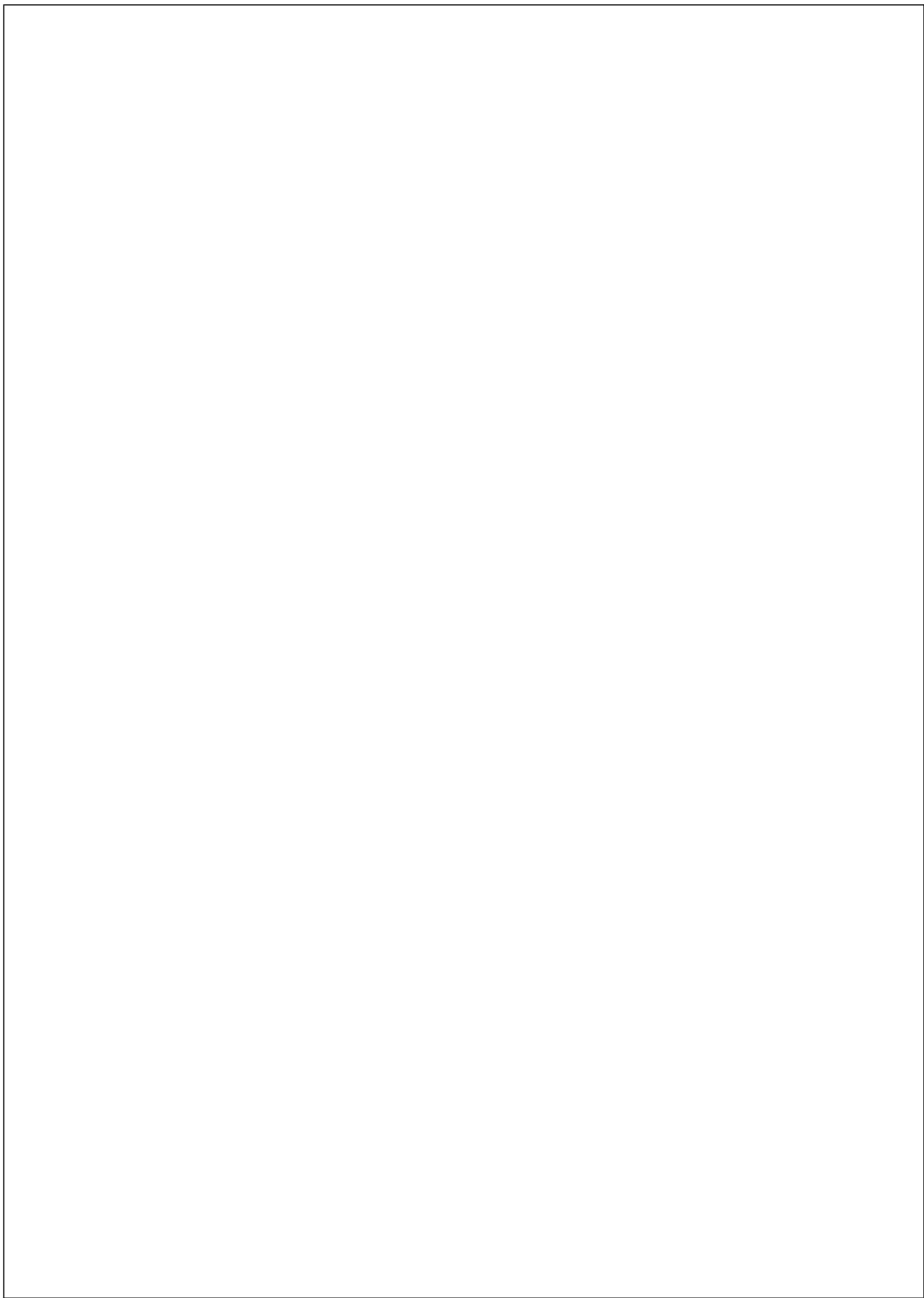

Physical Dimensions inches (millimeters) unless otherwise noted

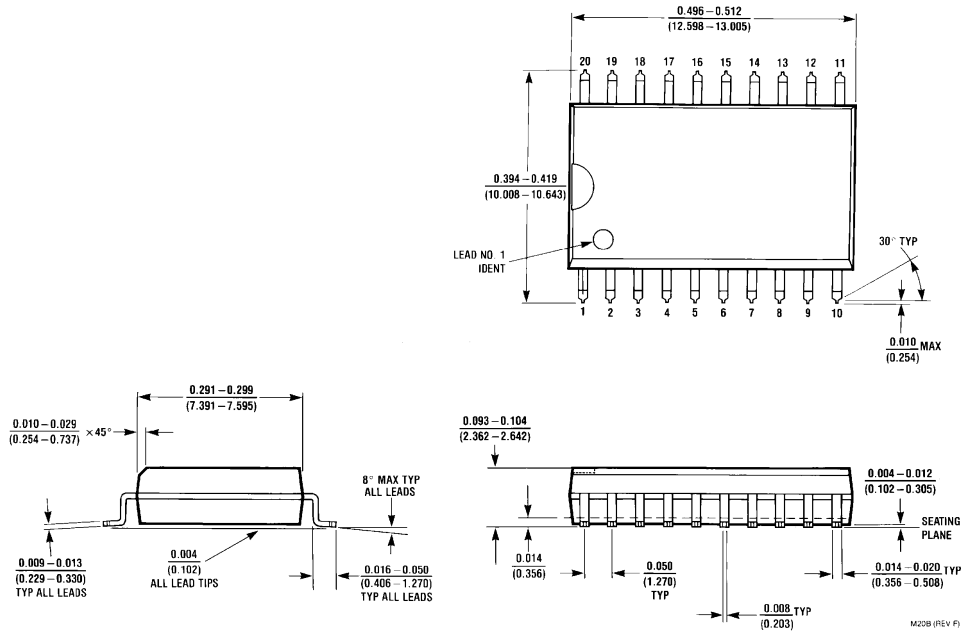

**Order Number DS36954M
NS Package Number M20B**

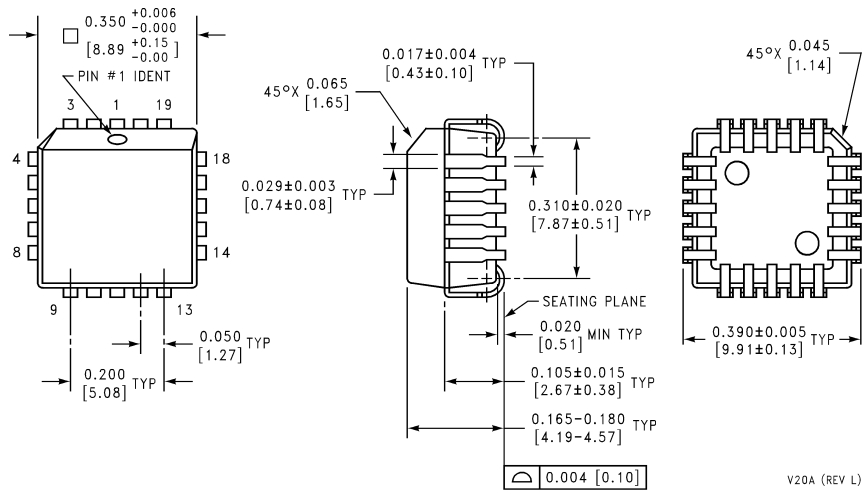

**Order Number DS36954V
NS Package Number V20A**

LIFE SUPPORT POLICY

NATIONAL'S PRODUCTS ARE NOT AUTHORIZED FOR USE AS CRITICAL COMPONENTS IN LIFE SUPPORT DEVICES OR SYSTEMS WITHOUT THE EXPRESS WRITTEN APPROVAL OF THE PRESIDENT OF NATIONAL SEMICONDUCTOR CORPORATION. As used herein:

1. Life support devices or systems are devices or systems which, (a) are intended for surgical implant into the body, or (b) support or sustain life, and whose failure to perform when properly used in accordance with instructions for use provided in the labeling, can be reasonably expected to result in a significant injury to the user.
2. A critical component is any component of a life support device or system whose failure to perform can be reasonably expected to cause the failure of the life support device or system, or to affect its safety or effectiveness.



National Semiconductor Corporation
Americas
Tel: 1-800-272-9959
Fax: 1-800-737-7018
Email: support@nsc.com

www.national.com

National Semiconductor Europe
Fax: +49 (0) 1 80-530 85 86
Email: europe.support@nsc.com
Deutsch Tel: +49 (0) 1 80-530 85 85
English Tel: +49 (0) 1 80-532 78 32
Français Tel: +49 (0) 1 80-532 93 58
Italiano Tel: +49 (0) 1 80-534 16 80

National Semiconductor Asia Pacific Customer Response Group
Tel: 65-2544466
Fax: 65-2504466
Email: sea.support@nsc.com

National Semiconductor Japan Ltd.
Tel: 81-3-5639-7560
Fax: 81-3-5639-7507