

DS7820 Dual Line Receiver

General Description

The DS7820, specified from -55°C to $+125^{\circ}\text{C}$, is a digital line receiver with two completely independent units fabricated on a single silicon chip. Intended for use with digital systems connected by twisted pair lines, they have a differential input designed to reject large common mode signals while responding to small differential signals. The output is directly compatible with TTL or LS integrated circuits.

The response time can be controlled with an external capacitor to eliminate noise spikes, and the output state is determined for open inputs. Termination resistors for the twisted pair line are also included in the circuit. The DS7820 is speci-

fied, worst case, over the full operating temperature range, for ± 10 -percent supply voltage variations and over the entire input voltage range.

Features

- Operation from a single +5V logic supply
- Input voltage range of $\pm 15\text{V}$
- Each channel can be strobed independently
- High input resistance
- Fan out of two with TTL integrated circuits
- Strobe low forces output to "1" state

Connection Diagram

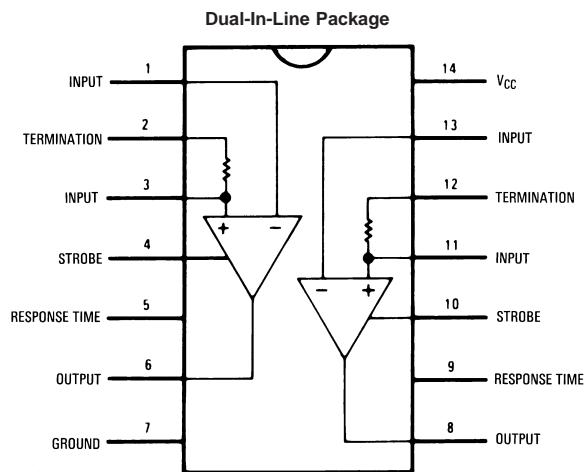

Top View

For Complete Military 883 Specifications, See RETS Data Sheet.
Order Number: DS7820J/883
See NS Package Number J14A

Absolute Maximum Ratings (Note 2)

If Military/Aerospace specified devices are required, please contact the National Semiconductor Sales Office/Distributors for availability and specifications.

Supply Voltage	8.0V
Input Voltage	±20V
Differential Input Voltage	±20V
Strobe Voltage	8.0V
Output Sink Current	25 mA

Storage Temperature Range	-65°C to +150°C
Lead Temperature (Soldering, 4 sec.)	260°C
Maximum Power Dissipation at 25°C (Note 1)	1308 mW

Operating Conditions

	Min	Max	Units
Supply Voltage (V_{CC})	4.5	5.5	V
Temperature (T_A)	-55	+125	°C

Electrical Characteristics (Notes 3, 4)

Symbol	Parameter	Conditions	Min	Typ	Max	Units
V_{TH}	Input Threshold Voltage	$V_{CM} = 0V$	-0.5	0	0.5	V
		$-15V \leq V_{CM} \leq 15V$	-1.0	0	1.0	V
V_{OH}	High Output Level	$I_{OUT} \leq 0.2 \text{ mA}$	2.5		5.5	V
V_{OL}	Low Output Level	$I_{SINK} \leq 3.5 \text{ mA}$	0		0.4	V
R_I^-	Inverting Input Resistance		3.6	5.0		k Ω
R_I^+	Non-Inverting Input Resistance		1.8	2.5		k Ω
R_T	Line Termination Resistance	$T_A = 25^\circ\text{C}$	120	170	250	Ω
t_r	Response Time	$C_{DELAY} = 0 \text{ pF}$		40		ns
		$C_{DELAY} = 100 \text{ pF}$		150		ns
I_{ST}	Strobe Current	$V_{STROBE} = 0.4V$		-1.0	-1.4	mA
		$V_{STROBE} = 5.5V$			5.0	μA
I_{CC}	Power Supply Current	$V_{IN} = 15V$		3.2	6.0	mA
		$V_{IN} = 0V$		5.8	10.2	mA
		$V_{IN} = -15V$		8.3	15.0	mA
I_{IN}^+	Non-Inverting Input Current	$V_{IN} = 15V$		5.0	7.0	mA
		$V_{IN} = 0V$	-1.6	-1.0		mA
		$V_{IN} = -15V$	-9.8	-7.0		mA
I_{IN}^-	Inverting Input Current	$V_{IN} = 15V$		3.0	4.2	mA
		$V_{IN} = 0V$		0	-0.5	mA
		$V_{IN} = -15V$	-4.2	-3.0		mA

Note 1: Derate cavity package 8.7 mW/°C above 25°C.

Note 2: "Absolute Maximum Ratings" are those values beyond which the safety of the device cannot be guaranteed. Except for "Operating Temperature Range" they are not meant to imply that the devices should be operated at these limits. The table of "Electrical Characteristics" provides conditions for actual device operation.

Note 3: These specifications apply for $4.5V \leq V_{CC} \leq 5.5V$, $-15V \leq V_{CM} \leq 15V$ and $-55^\circ\text{C} \leq T_A \leq +125^\circ\text{C}$ unless otherwise specified; typical values given are for $V_{CC} = 5.0V$, $T_A = 25^\circ\text{C}$ and $V_{CM} = 0$ unless stated differently.

Note 4: All currents into device pins shown as positive, out of device pins as negative, all voltages referenced to ground unless otherwise noted. All values shown as max or min on absolute value basis.

Note 5: The specifications and curves given are for one side only. Therefore, the total package dissipation and supply currents will be double the values given when both receivers are operated under identical conditions.

Typical Performance Characteristics (Note 4)

Supply Voltage Sensitivity

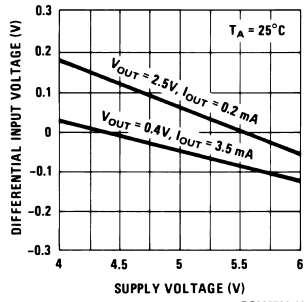

Common Mode Rejection

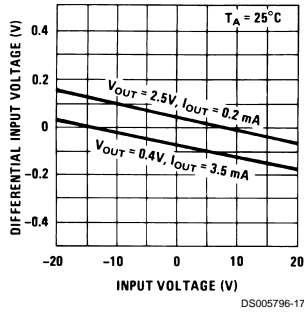

Transfer Function

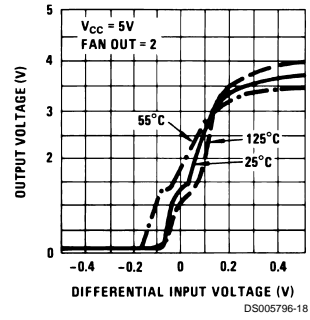

Response Time

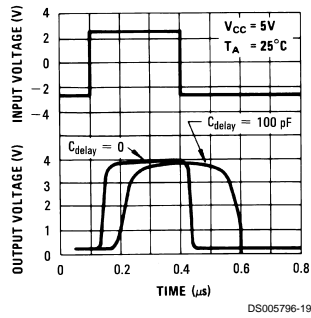

Output Voltage Levels

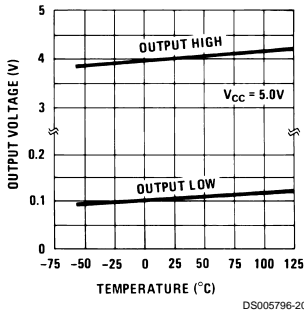

Termination Resistance

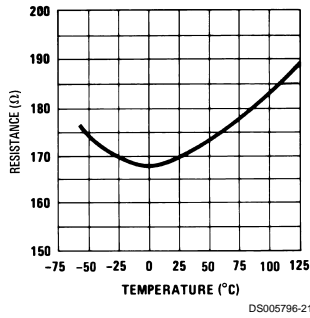

Positive Supply Current

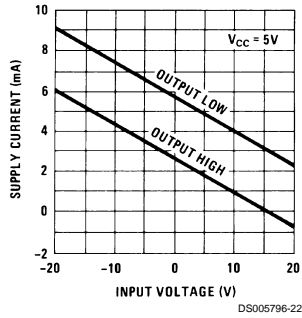

Internal Power Dissipation

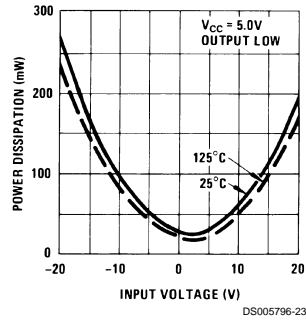

Typical Application

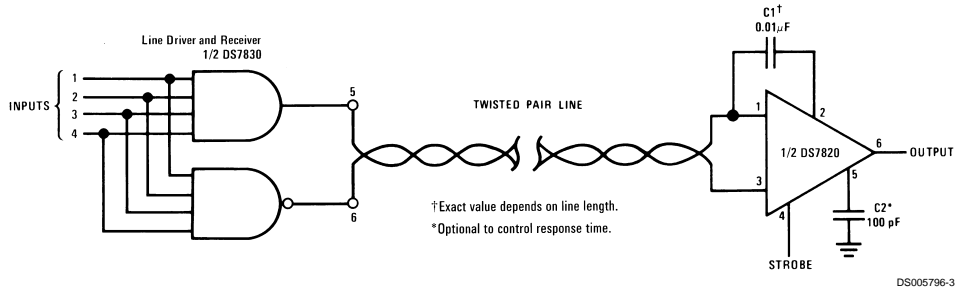

Schematic Diagram

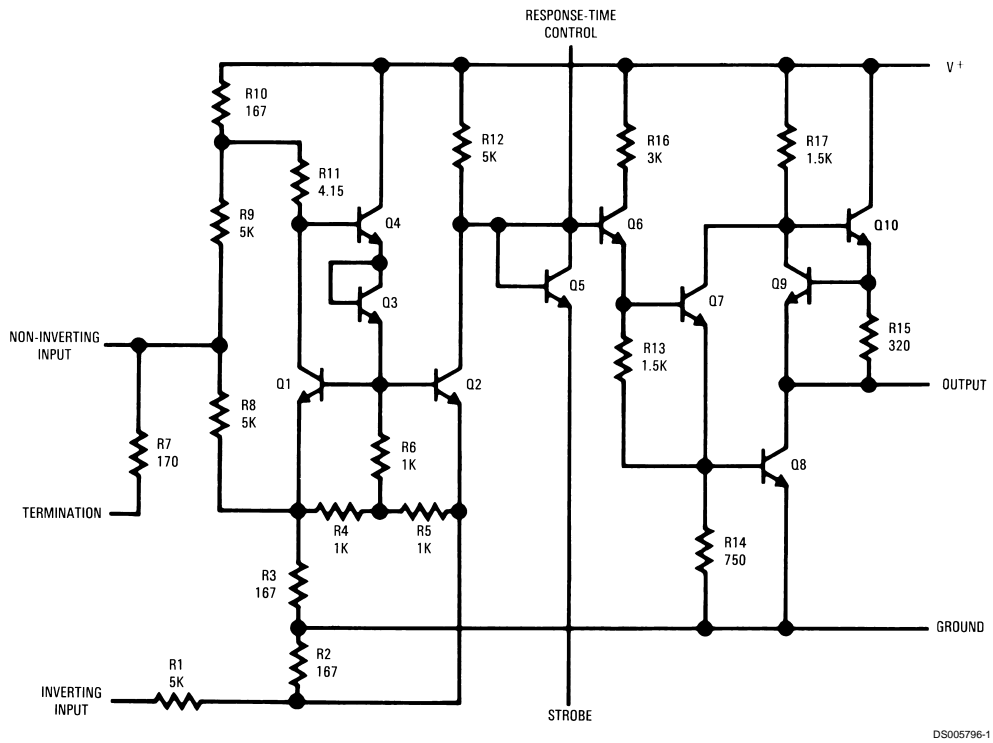

Physical Dimensions inches (millimeters) unless otherwise noted

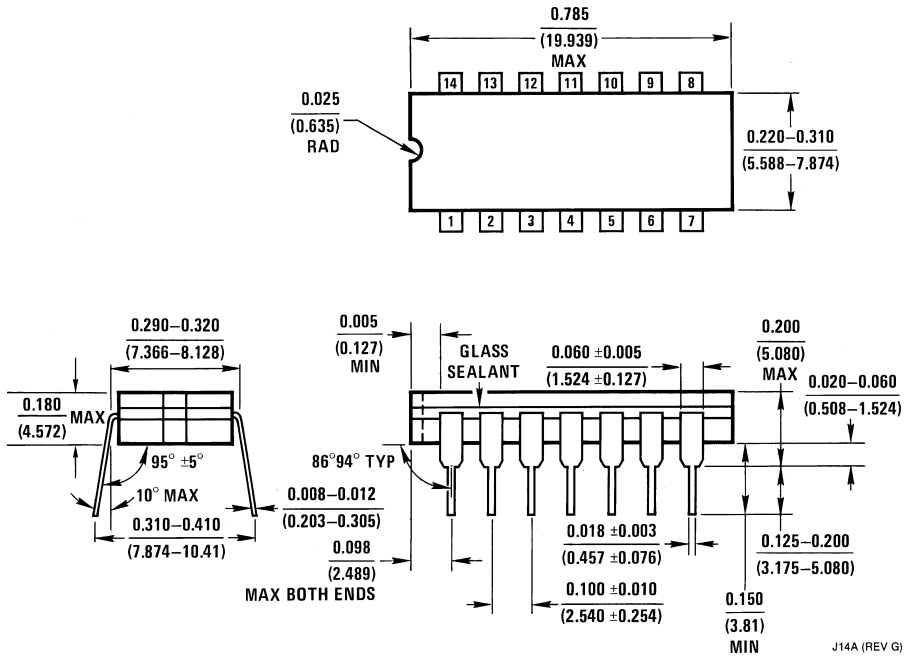

Ceramic Dual-In-Line Package (J)
Order Number DS7820J/883
NS Package Number J14A

LIFE SUPPORT POLICY

NATIONAL'S PRODUCTS ARE NOT AUTHORIZED FOR USE AS CRITICAL COMPONENTS IN LIFE SUPPORT DEVICES OR SYSTEMS WITHOUT THE EXPRESS WRITTEN APPROVAL OF THE PRESIDENT AND GENERAL COUNSEL OF NATIONAL SEMICONDUCTOR CORPORATION. As used herein:

1. Life support devices or systems are devices or systems which, (a) are intended for surgical implant into the body, or (b) support or sustain life, and whose failure to perform when properly used in accordance with instructions for use provided in the labeling, can be reasonably expected to result in a significant injury to the user.
2. A critical component is any component of a life support device or system whose failure to perform can be reasonably expected to cause the failure of the life support device or system, or to affect its safety or effectiveness.



National Semiconductor Corporation
 Americas
 Tel: 1-800-272-9959
 Fax: 1-800-737-7018
 Email: support@nsc.com

National Semiconductor Europe
 Fax: +49 (0) 1 80-530 85 86
 Email: europe.support@nsc.com
 Deutsch Tel: +49 (0) 1 80-530 85 85
 English Tel: +49 (0) 1 80-532 78 32
 Français Tel: +49 (0) 1 80-532 93 58
 Italiano Tel: +49 (0) 1 80-534 16 80

National Semiconductor Asia Pacific Customer Response Group
 Tel: 65-2544466
 Fax: 65-2504466
 Email: sea.support@nsc.com

National Semiconductor Japan Ltd.
 Tel: 81-3-5639-7560
 Fax: 81-3-5639-7507

www.national.com