

## DS92LV1212 16-40 MHz 10-Bit Bus LVDS Random Lock Deserializer with Embedded Clock Recovery

### General Description

The DS92LV1212 is an upgrade of the DS92LV1210. It maintains all of the features of the DS92LV1210 with the additional capability of locking to the incoming data stream without the need of SYNC patterns. This makes the DS92LV1212 useful in applications where the Deserializer must be operated "open-loop"—without a feedback path from the Deserializer to the Serializer. The DS92LV1212 is designed to be used with the DS92LV1021 Bus LVDS Serializer. The DS92LV1212 receives a Bus LVDS serial data stream and transforms it into a 10-bit wide parallel data bus and separate clock. The reduced cable, PCB trace count and connector size saves cost and makes PCB layout easier. Clock-to-data and data-to-data skews are eliminated since one input receives both clock and data bits serially. The powerdown pin is used to save power by reducing the supply current when the device is not in use. The Deserializer will establish lock to a synchronization pattern within specified lock times but it can also lock to a data stream without SYNC patterns.

### Features

- Clock recovery without SYNC patterns-random lock
- Guaranteed transition every data transfer cycle
- Chipset (Tx + Rx) power consumption < 300mW (typ) @ 40MHz
- Single differential pair eliminates multi-channel skew
- 400 Mbps serial Bus LVDS bandwidth (at 40 MHz clock)
- 10-bit parallel interface for 1 byte data plus 2 control bits or UTOPIA I Interface
- Synchronization mode and LOCK indicator
- Flow-through pinout for easy PCB layout
- High impedance on receiver inputs when power is off
- Programmable edge trigger on clock
- Footprint compatible with DS92LV1210
- Small 28-lead SSOP package-MSA

### Block Diagram

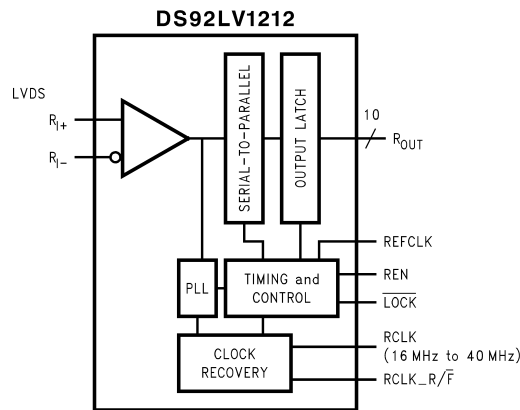

TRI-STATE® is a registered trademark of National Semiconductor Corporation.

## Block Diagram (Continued)

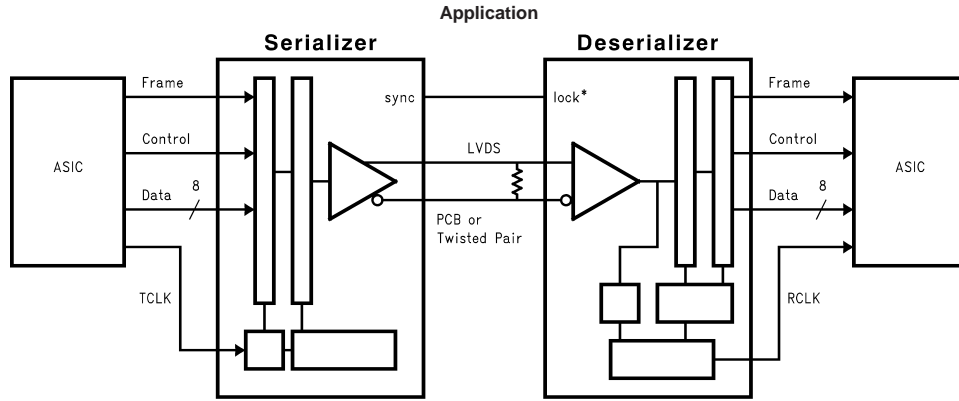

## Functional Description

The DS92LV1212 is a 10-bit Deserializer chip designed to receive data over a heavily loaded differential backplanes at clock speeds from 16 MHz to 40 MHz. It may also be used to receive data over Unshielded Twisted Pair (UTP) cable.

The chip has three active states of operation: Initialization, Data Transfer, and Resynchronization; and two passive states: Powerdown and TRI-STATE®.

The following sections describe each operation and passive state.

### Initialization

Before data can be transferred the Deserializer must be initialized. The Deserializer should be powered up with the PWRDN pin held low. After  $V_{CC}$  stabilizes the PWRDN pin can be forced high. The Deserializer is ready to lock to the incoming data stream.

Step 1: When  $V_{CC}$  is applied to the Deserializer, the respective outputs are held in TRI-STATE and internal circuitry is disabled by on-chip power-on circuitry. When  $V_{CC}$  reaches  $V_{CC}$  OK (2.5V) the PLL is ready to lock to incoming data or synchronization patterns. The local clock is applied to the REFCLK pin.

The Deserializer  $\overline{LOCK}$  output will remain high while its PLL is locking to the incoming data or to SYNC patterns on the input.

Step 2: The Deserializer PLL must synchronize to the Serializer to complete the initialization. The Deserializer will lock to non-repetitive data patterns, however, the transmission of SYNC patterns to the Deserializer enables the Deserializer to lock to the Serializer signal within a specified time.

Control of the Serializer SYNC1/2 pins is left to the user. A feedback loop between the  $\overline{LOCK}$  pin is one recommendation. Another option is that one or both of the Serializer SYNC inputs are asserted for at least 1024 cycles of TCLK to initiate transmission of SYNC patterns. The Serializer will continue to send SYNC patterns after the minimum of 1024 if either of the SYNC inputs remain high.

When the Deserializer detects edge transitions at the Bus LVDS input it will attempt to lock to the embedded clock in-

formation. When the Deserializer locks to the Bus LVDS clock, the  $\overline{LOCK}$  output will go low. When  $\overline{LOCK}$  is low the Deserializer outputs represent incoming Bus LVDS data.

### Data Transfer

Serialized data and clock bits (10+2 bits) are received at 12 times the TCLK frequency. For example, if TCLK is 40 MHz, the serial rate is  $40 \times 12 = 480$  Mega bits per second. Since only 10 bits are from input data, the serial "payload" rate is 10 times the TCLK frequency. For instance, if TCLK = 40 MHz, the payload data rate is  $40 \times 10 = 400$  Mbps. TCLK is provided by the data source and must be in the range 16 MHz to 40 MHz nominal.

The  $\overline{LOCK}$  pin on the Deserializer is driven low when it is synchronized with the Serializer. The Deserializer locks to the embedded clock and uses it to recover the serialized data. ROUT data is valid when  $\overline{LOCK}$  is low. Otherwise ROUT0-ROUT9 is invalid.

RCLK pin is the reference to data on the ROUT0-ROUT9 pins. The polarity of the RCLK edge is controlled by the RCLK\_R/F input.

ROUT(0-9),  $\overline{LOCK}$  and RCLK outputs will drive a minimum of three CMOS input gates (15 pF load) with 40 MHz clock.

### Resynchronization

The Deserializer  $\overline{LOCK}$  pin driven low indicates that the Deserializer PLL is locked to the embedded clock edge. If the Deserializer loses lock, the  $\overline{LOCK}$  output will go high and the outputs (including RCLK) will be TRI-STATE.

The  $\overline{LOCK}$  pin must be monitored by the system to detect a loss of synchronization. The system can arrange to pulse the Serializer SYNC1 or SYNC2 pin to resynchronize. There are multiple approaches possible. One recommendation is to provide a feedback loop using the  $\overline{LOCK}$  pin itself to control the sync request of the Serializer (SYNC1 or SYNC2). A minimum of 1024 sync patterns are needed to resynchronize. Dual SYNC pins are provided for multiple control in a multi-drop application.

## Random Lock Initialization and Resynchronization

The initialization and resynchronization methods described in their respective sections are the fastest ways to establish the link between the Serializer and Deserializer, however, the DS92LV1212 can attain lock to a data stream without requiring special SYNC patterns to be sent by the Serializer. This allows the DS92LV1212 to be used in applications where the Deserializer must operate "open-loop" and supports hot insertion into a running backplane. Because the data stream is essentially random the time for the DS92LV1212 to attain lock is variable and cannot be predicted. The primary constraint on the "random" lock time is the initial phase relation when the Deserializer is powered up. The data contained in the data stream can also affect lock time. Typical lock times for random data have a mean of 570us and a max of 4.9ms.

If a specific pattern is repetitive the Deserializer could be misled into a "false lock" - falsely recognizing the data pattern as the clocking bits. We refer to such a pattern as a repetitive multi-transition, RMT. This is when there is more than one Low-High transition in a single clock cycle. This occurs when any bit, except DIN 9, is held at a low state and the adjacent bit is held high creating a 0-1 transition. In the worst case the Deserializer could become locked to the data pattern rather than the clock. Circuitry within the DS92LV1212 can detect that the possibility of "false lock" exists (by detecting that there is more than 1 potential position for clocking bits) and will prevent the LOCK\* output from becoming active until the potential "false lock" pattern changes. It is expected that the data will eventually change causing the Deserializer to lose lock to the data pattern and continue searching for the clock bits in the serial data stream. A graphical representation of a few cases of RMT is shown below. Please note that RMT applies to bits DIN0-DIN8.

## Powerdown

The Powerdown state is a low power sleep mode that can be used to reduce power when there is no data to be transferred. Powerdown is entered when  $\overline{\text{PWRDN}}$  and REN are driven low on the Deserializer. In Powerdown, the PLL is stopped and the outputs go into TRI-STATE, disabling load current and also reducing supply current to the milliamp range. To exit Powerdown,  $\overline{\text{PWRDN}}$  is driven high.

Both the Serializer and Deserializer must re-initialize and resynchronize before data can be transferred. Initialization of the Serializer takes 1024 TCLK cycles. The Deserializer will initialize and assert LOCK high until it is locked to the Bus LVDS clock.

## TRI-STATE

For the Deserializer, TRI-STATE is entered when the REN pin is driven low. This will TRI-STATE the receiver output pins (ROUT0-ROUT9), LOCK and RCLK.

## RMT Patterns

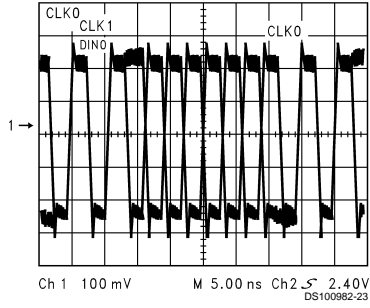

DIN0 Held Low-DIN1 Held High Creates an RMT Pattern

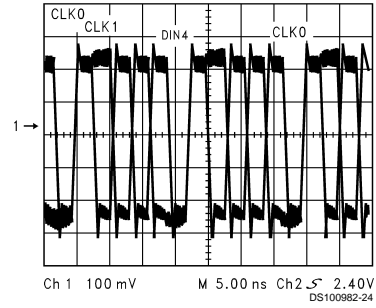

DIN4 Held Low-DIN5 Held High Creates an RMT Pattern

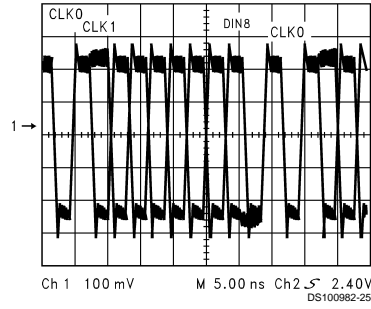

DIN8 Held Low-DIN9 Held High Creates an RMT Pattern

### Order Numbers

NSID	Function	Package
DS92LV1021TMSA	Serializer	MSA28
DS92LV1212TMSA	Deserializer	MSA28

## Absolute Maximum Ratings (Note 1)

If Military/Aerospace specified devices are required, please contact the National Semiconductor Sales Office/Distributors for availability and specifications.

Supply Voltage ( $V_{CC}$ )	-0.3V to +4V
CMOS/TTL Input Voltage	-0.3V to ( $V_{CC} + 0.3V$ )
CMOS/TTL Output Voltage	-0.3V to ( $V_{CC} + 0.3V$ )
Bus LVDS Receiver Input Voltage	-0.3V to +3.9V
Junction Temperature	+150°C
Storage Temperature	-65°C to +150°C
Lead Temperature (Soldering, 4 seconds)	+260°C
Maximum Package Power Dissipation Capacity @ 25°C Package: 28L SSOP	1.27 W

Package Derating:

28L SSOP	10.2 mW/°C above +25°C
ESD Rating (HBM)	>2.5kV

## Recommended Operating Conditions

	Min	Nom	Max	Units
Supply Voltage ( $V_{CC}$ )	3.0	3.3	3.6	V
Operating Free Air Temperature ( $T_A$ )	-40	+25	+85	°C
Receiver Input Range	0		2.4	V
Supply Noise Voltage ( $V_{CC}$ )			100	mV <sub>P-P</sub>

## Electrical Characteristics

Over recommended operating supply and temperature ranges unless otherwise specified.

Symbol	Parameter	Conditions	Min	Typ	Max	Units	
<b>DESERIALIZER CMOS/TTL DC SPECIFICATIONS (apply to pins PWRDN, RCLK_R/F, REN, REFCLK = inputs; apply to pins ROUT, RCLK, LOCK = outputs)</b>							
$V_{IH}$	High Level Input Voltage		2.0		$V_{CC}$	V	
$V_{IL}$	Low Level Input Voltage		GND		0.8	V	
$V_{CL}$	Input Clamp Voltage	$I_{CL} = -18$ mA		-0.62	-1.5	V	
$I_{IN}$	Input Current	$V_{IN} = 0V$ or 3.6V	-10	±2	+10	µA	
$V_{OH}$	High Level Output Voltage	$I_{OH} = -9$ mA	2.1	2.93	$V_{CC}$	V	
$V_{OL}$	Low Level Output Voltage	$I_{OL} = 9$ mA	GND	0.33	0.6	V	
$I_{OS}$	Output Short Circuit Current	$V_{OUT} = 0V$	-15	-38	-85	mA	
$I_{OZ}$	TRI-STATE Output Current	$\overline{PWRDN}$ or REN = 0.8V, $V_{OUT} = 0V$ or VCC	-10	±0.4	+10	µA	
<b>DESERIALIZER Bus LVDS DC SPECIFICATIONS (apply to pins RI+ and RI-)</b>							
$V_{TH}$	Differential Threshold High Voltage	$V_{CM} = +1.1V$		+6	+100	mV	
$V_{TL}$	Differential Threshold Low Voltage		-100	-12		mV	
$I_{IN}$	Input Current	$V_{IN} = +2.4V$ , $V_{CC} = 3.6V$ or 0V	-10	±5	+10	µA	
		$V_{IN} = 0V$ , $V_{CC} = 3.6V$ or 0V	-10	±5	+10	µA	
<b>DESERIALIZER SUPPLY CURRENT (apply to pins DVCC and AVCC)</b>							
$I_{CCR}$	Deserializer Supply Current Worst Case	$C_L = 15$ pF <i>Figure 1</i>	$f = 40$ MHz		47	60	mA
			$f = 16$ MHz		30	40	mA
$I_{CCXR}$	Deserializer Supply Current Powerdown	$\overline{PWRDN} = 0.8V$ , REN = 0.8V		0.34	1.0	mA	

## Deserializer Timing Requirements for REFCLK

Over recommended operating supply and temperature ranges unless otherwise specified.

Symbol	Parameter	Conditions	Min	Typ	Max	Units
$t_{RFCP}$	REFCLK Period		25	T	62.5	ns
$t_{RFDC}$	REFCLK Duty Cycle			50		%
$f_{Ref}$	REFCLK Frequency		$0.95/t_{RCP}$	$t_{RCP}$	$1.05/t_{RCP}$	
$t_{RFTT}$	REFCLK Transition Time			3	6	ns

## Deserializer Switching Characteristics

Over recommended operating supply and temperature ranges unless otherwise specified.

Symbol	Parameter	Conditions	Pin/Freq.	Min	Typ	Max	Units
$t_{RCP}$	Receiver out Clock Period	Figure 3 $t_{RCP} = t_{TCP}$	RCLK	25		62.5	ns
$t_{CLH}$	CMOS/TTL Low-to-High Transition Time	CL = 15 pF Figure 2	Rout(0-9),		2	6	ns
$t_{CHL}$	CMOS/TTL High-to-Low Transition Time		LOCK, RCLK		2	6	ns
$t_{DD}$	Deserializer Delay	Figure 4		$1.75 \cdot t_{RCP} + 1.5$	$1.75 \cdot t_{RCP} + 4.0$	$1.75 \cdot t_{RCP} + 6.5$	ns
$t_{ROS}$	ROUT (0-9) Setup Data to RCLK	Figure 5	RCLK	$0.4 \cdot t_{RCP}$	$0.5 \cdot t_{RCP}$		ns
$t_{ROH}$	ROUT (0-9) Hold Data to RCLK			$-0.4 \cdot t_{RCP}$	$-0.5 \cdot t_{RCP}$		ns
$t_{RDC}$	RCLK Duty Cycle			40	50	60	%
$t_{HZR}$	HIGH to TRI-STATE Delay	Figure 6	Rout(0-9), LOCK		$4.2 + 0.5 \cdot t_{RCP}$	$10 + t_{RCP}$	ns
$t_{LZR}$	LOW to TRI-STATE Delay				$4.5 + 0.5 \cdot t_{RCP}$	$10 + t_{RCP}$	ns
$t_{ZHR}$	TRI-STATE to HIGH Delay				$6 + 0.5 \cdot t_{RCP}$	$12 + t_{RCP}$	ns
$t_{ZLR}$	TRI-STATE to LOW Delay				$6.0 + 0.5 \cdot t_{RCP}$	$12 + t_{RCP}$	ns
$t_{DSR1}$	Deserializer PLL Lock Time from PWRDWN (with SYNCPAT)			(Note 4) Figure 7 Figure 8	16MHz		18.2
$t_{DSR2}$	Deserializer PLL Lock time from SYNCPAT	40MHz			7.4	25.6	$\mu$ s
		16MHz			21.0	30	$\mu$ s
$t_{ZHLK}$	TRI-STATE to HIGH Delay (power-up)	40MHz			14.4	25	$\mu$ s
		LOCK			4.62	12	ns
$t_{RNM}$	Deserializer Noise Margin	16 MHz			400	1100	
		40 MHz		100	400		ps

**Note 1:** "Absolute Maximum Ratings" are those values beyond which the safety of the device cannot be guaranteed. They are not meant to imply that the devices should be operated at these limits. The table of "Electrical Characteristics" specifies conditions of device operation.

**Note 2:** Typical values are given for  $V_{CC} = 3.3V$  and  $T_A = +25^\circ C$ .

**Note 3:** Current into device pins is defined as positive. Current out of device pins is defined as negative. Voltages are referenced to ground except VOD,  $\Delta VOD$ , VTH and VTL which are differential voltages.

**Note 4:** For the purpose of specifying Deserializer PLL performance  $t_{DSR1}$  and  $t_{DSR2}$  are specified with the REFCLK running and stable, and specific conditions of the incoming data stream (SYNCPATs). It is recommended that the Deserializer be initialized using either  $t_{DSR1}$  timing or  $t_{DSR2}$  timing.  $t_{DSR1}$  is the time required for the Deserializer to indicate lock upon power-up or when leaving the power-down mode. Synchronization patterns should be sent to the device before initiating either condition.  $t_{DSR2}$  is the time required to indicate lock for the powered-up and enabled Deserializer when the input (RI+ and RI-) conditions change from not receiving data to receiving synchronization patterns (SYNCPATs).

**Note 5:**  $t_{RNM}$  is a measure of how much phase noise (jitter) the Deserializer can tolerate in the incoming data stream before bit errors occur.

## AC Timing Diagrams and Test Circuits

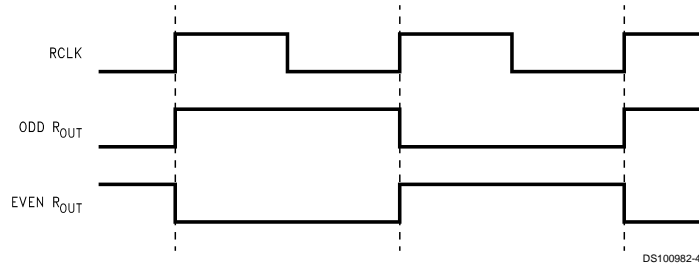

FIGURE 1. "Worst Case" Deserializer ICC Test Pattern

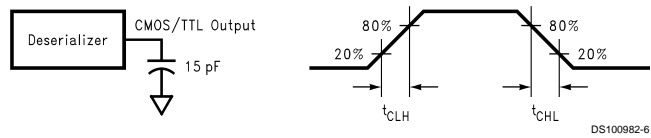

FIGURE 2. Deserializer CMOS/TTL Output Load and Transition Times

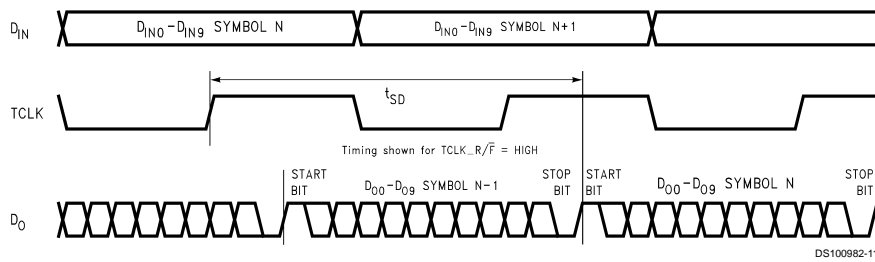

FIGURE 3. Serializer Delay

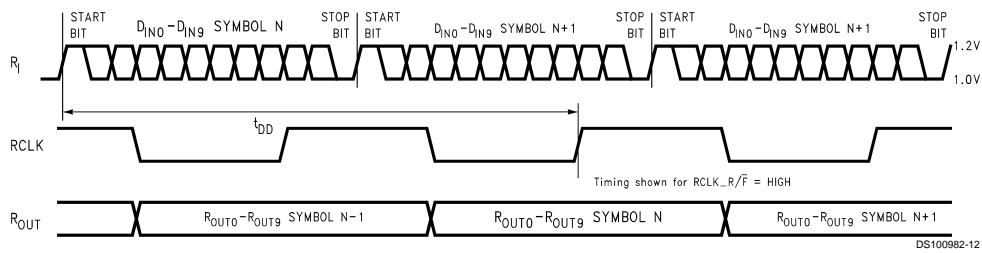
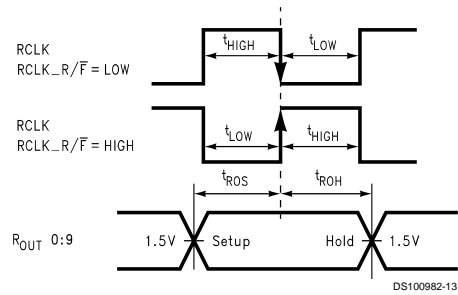

FIGURE 4. Deserializer Delay

## AC Timing Diagrams and Test Circuits (Continued)



Timing shown for  $RCLK\_R/\bar{F} = \text{LOW}$   
 Duty Cycle ( $t_{RDC}$ ) =  $\frac{t_{\text{HIGH}}}{t_{\text{HIGH}} + t_{\text{LOW}}}$

**FIGURE 5. Deserializer Setup and Hold Times**

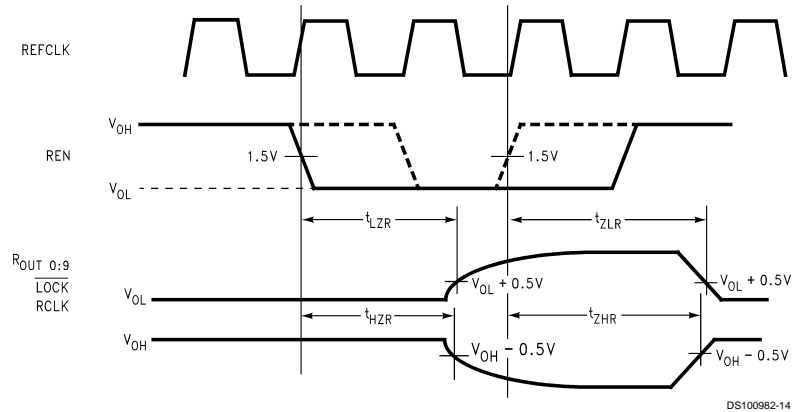

**FIGURE 6. Deserializer TRI-STATE Test Circuit and Timing**



## AC Timing Diagrams and Test Circuits (Continued)

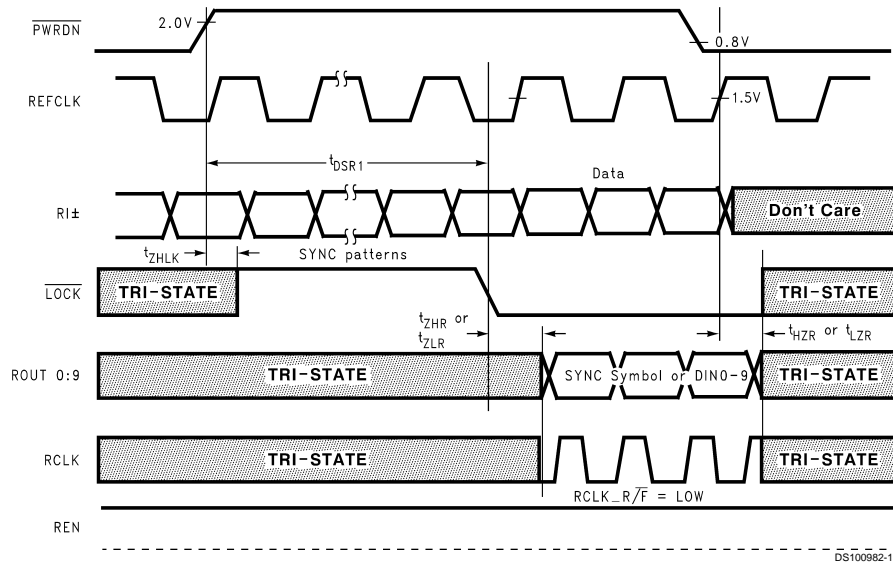

FIGURE 7. Deserializer PLL Lock Times and PWRDN TRI-STATE Delays

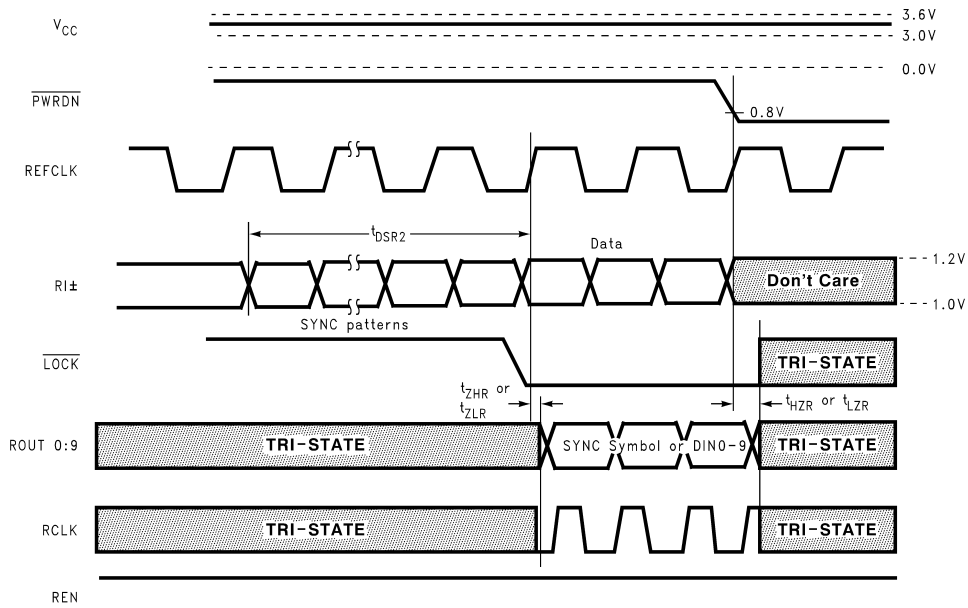
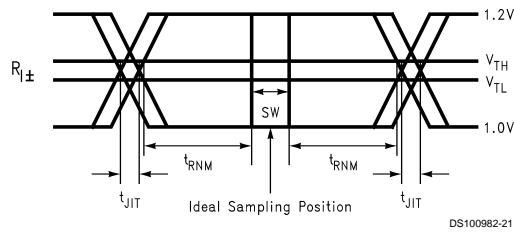

FIGURE 8. Deserializer PLL Lock Time from SyncPAT

## AC Timing Diagrams and Test Circuits (Continued)



SW - Setup and Hold Time (Internal data sampling window)  
 $t_{JIT}$  - Serializer Output Bit Position Jitter  
 $t_{RSM}$  = Receiver Sampling Margin Time

DS100982-21

FIGURE 9. Receiver Bus LVDS Input Skew Margin

## Application Information

### Using the DS92LV1021 and DS92LV1212

The Serializer and Deserializer chipset is an easy to use transmitter and receiver pair that sends 10 bits of parallel TTL data over a serial Bus LVDS link up to 400 Mbps. Serialization of the input data is accomplished using an onboard PLL at the Serializer which embeds two clock bits with the data. The Deserializer uses a separate reference clock (REFCLK) and an onboard PLL to extract the clock information from the incoming data stream and deserialize the data. The Deserializer monitors the incoming clock information to determine lock status and will indicate loss of lock by raising the  $\overline{\text{LOCK}}$  output.

### Power Considerations

All CMOS design of the Serializer and Deserializer makes them inherently low power devices. Additionally, the constant current source nature of the Bus LVDS outputs minimize the slope of the speed vs.  $I_{CC}$  curve of CMOS designs.

### Powering Up the Deserializer

The DS92LV1212 can be powered up at any time following the proper sequence. The REFCLK input can be running before the Deserializer is powered up and it must be running in order for the Deserializer to lock to incoming data. The Deserializer outputs will remain in TRI-STATE until the Deserializer detects data transmission at its inputs and locks to the incoming stream. The recommended power up sequence for the Deserializer is to power up all  $V_{CC}$  pins simultaneously with the PWRDWN pin held low for 1 $\mu$ s. Once the  $V_{CC}$  pins have stabilized the Deserializer is ready for locking. Another option to ensure proper power up is to cycle the PWRDWN pin from high to low and back to high after power up.

### Transmitting Data

Once the Serializer and Deserializer are powered up and running they must be phase locked to each other in order to transmit data. Phase locking is accomplished by the Deserializer locking to incoming data or by the Serializer sending SYNC patterns to the Deserializer. SYNC patterns are sent by the Serializer whenever SYNC1 or SYNC2 inputs are held high. The  $\overline{\text{LOCK}}$  output of the Deserializer is high whenever the Deserializer is not locked. Connecting the  $\overline{\text{LOCK}}$  output of the Deserializer to one of the SYNC inputs of the Serializer will guarantee that enough SYNC patterns are sent to achieve Deserializer lock.

The Deserializer can also be locked by simply powering up the device and allowing the "random lock" circuitry to find and lock to the data stream for the Serializer.

While the Deserializer  $\overline{\text{LOCK}}$  output is low, data at the Deserializer outputs (ROUT0-9) is valid except for the specific case of loss of lock during transmission.

### Noise Margin

The Deserializer noise margin is the amount of input jitter (phase noise) that the Deserializer can tolerate and still reliably receive data. Various environmental and systematic factors include:

Serializer: TCLK jitter,  $V_{CC}$  noise (noise bandwidth and out-of-band noise)

Media: ISI,  $V_{CM}$  noise

Deserializer:  $V_{CC}$  noise

### Recovering from LOCK Loss

In the case where the Serializer loses lock during data transmission up to 5 cycles of data that was previously received can be invalid. This is due to the delay in the lock detection circuit. The lock detect circuit requires that invalid clock information be received 4 times in a row to indicate loss of lock. Since clock information has been lost it is possible that data was also lost during these cycles. When the Deserializer  $\overline{\text{LOCK}}$  pin goes low, data from at least the previous 5 cycles should be resent upon regaining lock.

Lock can be regained at the Deserializer by causing the Serializer to resend SYNC patterns as described above or by random lock which can take more time depending upon the data patterns being received.

### Input Failsafe

In the event that the Deserializer is disconnected from the Serializer, the failsafe circuitry is designed to reject certain amount of noise from being interpreted as data or clock. The outputs will be tri-stated and the Deserializer will lose lock.

### Hot Insertion

All the BLVDS devices are hot pluggable if you follow a few rules. When inserting, ensure the Ground pin(s) makes contact first, then the VCC pin(s), then the I/O pins. When removing, the I/O pins should be unplugged first, then the VCC, then the Ground. Random lock hot insertion is illustrated in Figure 10.

### PCB Considerations

The Bus LVDS devices Serializer and Deserializer should be placed as close to the edge connector as possible. In multiple Deserializer applications, the distance from the Deserializer to the slot connector appears as a stub to the Serializer driving the backplane traces. Longer stubs lower the impedance of the bus increasing the load on the Serializer

## Application Information (Continued)

and lowers threshold margin at the Deserializers. Deserializer devices should be placed no more than 1 inch from the slot connector.

### Transmission Media

The Serializer and Deserializer are designed for data transmission over a multi-drop bus. Multi-drop buses use a single Serializer and multiple Deserializer devices. Since the Serializer can be driving from any point on the bus, the bus must be terminated at both ends. For example, a 100 Ohm differential bus must be terminated at each end with 100 Ohms lowering the DC impedance that the Serializer must drive to

50 Ohms. This load is further lowered by the addition of multiple Deserializers. Adding up to 20 Deserializers to the bus (depending upon spacing) will lower the total load to about 27 Ohms (54 Ohm bus). The Serializer is designed for DC loads between 27 and 100 Ohms.

The Serializer and Deserializer can also be used in point-to-point configuration of a backplane, PCB trace or through a twisted pair cable. In point-to-point configurations the transmission media need only be terminated at the receiver end. In the point-to-point configuration the potential of offsetting the ground levels of the Serializer vs. the Deserializer must be considered. Bus LVDS provides a plus / minus one volt common mode range at the receiver inputs.

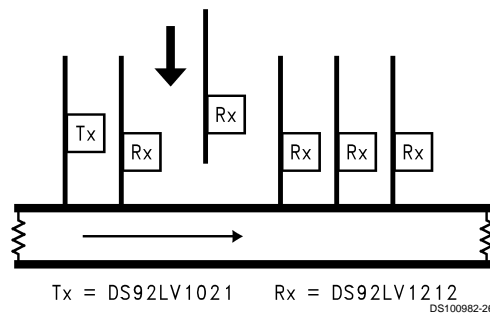

The DS92LV1212 can be "Hot Inserted" into operating serial busses without interrupting bus communication. The random lock feature allows the DS92LV1212 to synchronize to the bus traffic and receive data.

**FIGURE 10. Random Lock Allows Hot Insertion into Serial Busses**

## Pin Diagram

### DS92LV1212TMSA - Deserializer

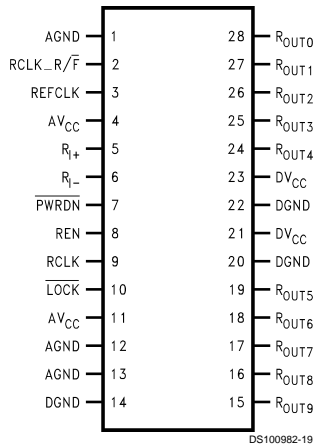

## Deserializer Pin Description

Pin Name	I/O	No.	Description
ROUT	O	15–19, 24–28	Data Output. ±9 mA CMOS level outputs.

## Deserializer Pin Description (Continued)

Pin Name	I/O	No.	Description
RCLK_R/ $\bar{F}$	I	2	Recovered Clock Rising/Falling strobe select. TTL level input. Selects RCLK active edge for strobing of ROUT data. High selects rising edge. Low selects falling edge.
RI+	I	5	+ Serial Data Input. Non-inverting Bus LVDS differential input.
RI-	I	6	- Serial Data Input. Inverting Bus LVDS differential input.
$\overline{PWRDN}$	I	7	Powerdown. TTL level input. $\overline{PWRDN}$ driven low shuts down the PLL.
$\overline{LOCK}$	O	10	$\overline{LOCK}$ goes low when the Deserializer PLL locks onto the embedded clock edge. CMOS level output. Totem pole output structure, does not directly support wire OR connection.
RCLK	O	9	Recovered Clock. Parallel data rate clock recovered from embedded clock. Used to strobe ROUT, CMOS level output.
REN	I	8	Output Enable. TTL level input. TRI-STATEs ROUT0-ROUT9, $\overline{LOCK}$ and RCLK when driven low.
DVCC	I	21, 23	Digital Circuit power supply.
DGND	I	14, 20, 22	Digital Circuit ground.
AVCC	I	4, 11	Analog power supply (PLL and Analog Circuits).
AGND	I	1, 12, 13	Analog ground (PLL and Analog Circuits).
REFCLK	I	3	Use this pin to supply a REFCLK signal for the internal PLL frequency.

### Truth Table

RI	RI-	RCLK_R/ $\bar{F}$	REFCLK	REN	$\overline{PWRDN}$	RCLK	$\overline{LOCK}$	ROUT (0-9)
X	X	X	SYSTEM CLK	X	0	Z	Z	Z
Z	Z	X	SYSTEM CLK	X	X	Z	Z	Z
DATA (0-9)	DATA (0-9)*	X	SYSTEM CLK	0	1	Z	L $\rightarrow$ Z **	Z
DATA (0-9)	DATA (0-9)*	X	SYSTEM CLK	0	1	Z	H $\rightarrow$ PLL **	Z
SYNC PTRN	SYNC PTRN*	X	SYSTEM CLK	1	1	CLK	1	SYNC PTRN
DATA (0-9)	DATA (0-9)*	1	SYSTEM CLK	1	1	$\bar{L}$	0	DATA
DATA (0-9)	DATA (0-9)*	0	SYSTEM CLK	1	1	$\bar{H}$	0	DATA

\* Inverted

\*\*If the Rx is locked when REN goes low the  $\overline{LOCK}^*$  output will go Tri-state on the rising edge of REFCLK. If the Rx is not locked when REN goes low the  $\overline{LOCK}^*$  output will remain active. It will be high as the Rx is not locked but should the Rx attain lock the  $\overline{LOCK}^*$  output will go low to indicate lock.

**Physical Dimensions** inches (millimeters) unless otherwise noted

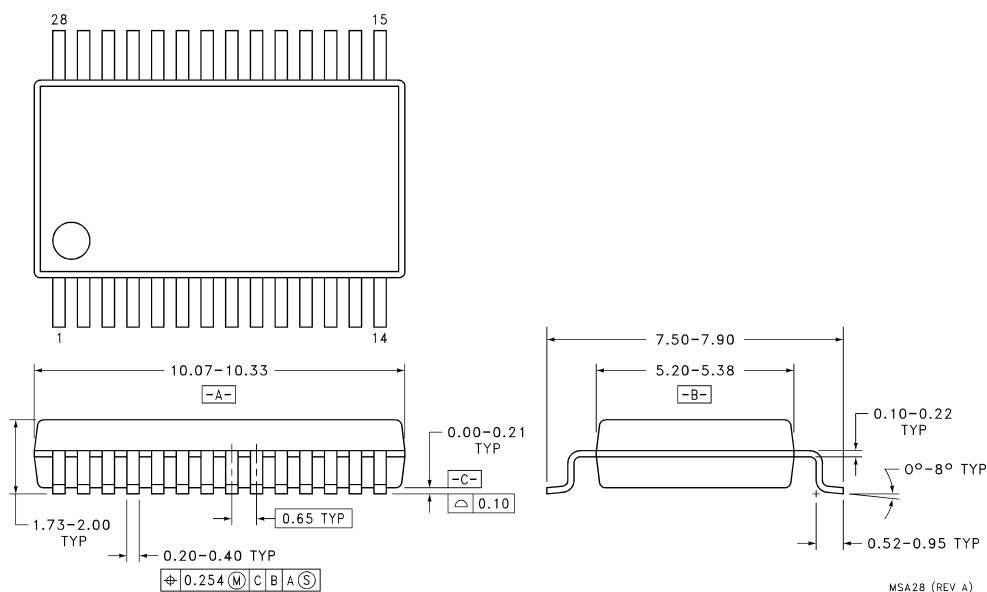

Order Number DS92LV1021TMSA or DS92LV1212TMSA  
NS Package Number MSA28

MSA28 (REV A)

**LIFE SUPPORT POLICY**

NATIONAL'S PRODUCTS ARE NOT AUTHORIZED FOR USE AS CRITICAL COMPONENTS IN LIFE SUPPORT DEVICES OR SYSTEMS WITHOUT THE EXPRESS WRITTEN APPROVAL OF THE PRESIDENT AND GENERAL COUNSEL OF NATIONAL SEMICONDUCTOR CORPORATION. As used herein:

1. Life support devices or systems are devices or systems which, (a) are intended for surgical implant into the body, or (b) support or sustain life, and whose failure to perform when properly used in accordance with instructions for use provided in the labeling, can be reasonably expected to result in a significant injury to the user.
2. A critical component is any component of a life support device or system whose failure to perform can be reasonably expected to cause the failure of the life support device or system, or to affect its safety or effectiveness.

**National Semiconductor Corporation**  
Americas  
Tel: 1-800-272-9959  
Fax: 1-800-737-7018  
Email: support@nsc.com

www.national.com

**National Semiconductor Europe**  
Fax: +49 (0) 1 80-530 85 86  
Email: europe.support@nsc.com  
Deutsch Tel: +49 (0) 1 80-530 85 85  
English Tel: +49 (0) 1 80-532 78 32  
Français Tel: +49 (0) 1 80-532 93 58  
Italiano Tel: +49 (0) 1 80-534 16 80

**National Semiconductor Asia Pacific Customer Response Group**  
Tel: 65-2544466  
Fax: 65-2504466  
Email: sea.support@nsc.com

**National Semiconductor Japan Ltd.**  
Tel: 81-3-5639-7560  
Fax: 81-3-5639-7507