

DS96F172C/DS96F172M/DS96F174C/DS96F174M EIA-485/EIA-422 Quad Differential Drivers

General Description

The DS96F172 and the DS96F174 are high speed quad differential line drivers designed to meet EIA-485 Standards. The DS96F172 and the DS96F174 offer improved performance due to the use of L-FAST bipolar technology. The use of LFAST technology allows the DS96F172 and DS96F174 to operate at higher speeds while minimizing power consumption.

The DS96F172 and the DS96F174 have TRI-STATE® outputs and are optimized for balanced multipoint data bus transmission at rates up to 15 Mbps. The drivers have wide positive and negative common mode range for multipoint applications in noisy environments. Positive and negative current-limiting is provided which protects the drivers from line fault conditions over a +12V to -7.0V common mode range. A thermal shutdown feature is also provided. The DS96F172 features an active high and active low Enable, common to all four drivers. The DS96F174 features separate active high Enables for each driver pair.

Features

- Meets EIA-485 and EIA-422 standards
- Monotonic differential output switching
- TRI-STATE outputs
- Designed for multipoint bus transmission
- Common mode output voltage range: -7.0V to +12V
- Operates from single +5.0V supply
- Reduced power consumption
- Thermal shutdown protection
- DS96F172 and DS96F174 are lead and function compatible with the SN75172/174 or the AM26LS31/MC3487
- Military temperature range available
- Qualified for MIL-STD-883C
- Standard military drawings available (SMD)
- Available in DIP (J), LCC (E), and Flatpak (W) packages

Logic Diagrams

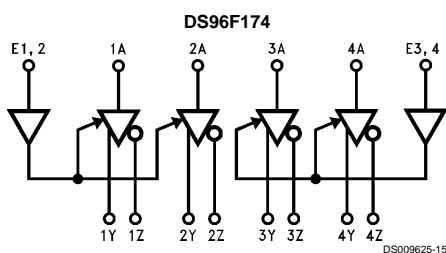
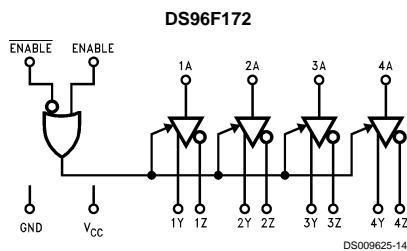

Function Tables (Each Driver)

DS96F172

Input	Enable		Outputs	
	E	\bar{E}	Y	Z
H	H	X	H	L
L	H	X	L	H
H	X	L	H	L
L	X	L	L	H
X	L	H	Z	Z

DS96F174

Input	Enable	Outputs	
		Y	Z
H	H	H	L
L	H	L	H
X	L	Z	Z

H = High Level
 L = Low Level
 X = Don't Care
 Z = High Impedance (Off)

TRI-STATE® is a registered trademark of National Semiconductor Corporation.

COMMERCIAL

Absolute Maximum Ratings (Note 2)

Specifications for the 883 version of this product are listed separately on the following pages.

Storage Temperature Range (T_{STG})	-65°C to +175°C
Lead Temperature (Soldering, 60 sec.)	300°C
Maximum Package Power Dissipation (Note 1) at 25°C	
Ceramic DIP (J)	1500 mW
Supply Voltage	7.0V
Enable Input Voltage	5.5V

Recommended Operating Conditions

	Min	Typ	Max	Units
Supply Voltage (V_{CC})				
DS96F172C/DS96F174C	4.75	5.0	5.25	V
Common Mode	-7.0		+12.0	V
Output Voltage (V_{OC})				
Output Current HIGH (I_{OH})			-60	mA
Output Current LOW (I_{OL})			60	mA
Operating Temperature (T_A)				
DS96F172C/DS96F174C	0		+70	°C

Note 1: Derate "J" package 10 mW/°C above 25°C.

Electrical Characteristics (Notes 3, 4)

Over recommended supply voltage and operating temperature range, unless otherwise specified

Symbol	Parameter	Conditions	Min	Typ (Note 2)	Max	Units
V_{IH}	Input Voltage HIGH		2.0			V
V_{IL}	Input Voltage LOW				0.8	V
		$T_A = 0^\circ\text{C to } +70^\circ\text{C}$				
		$T_A = -55^\circ\text{C to } +125^\circ\text{C}$			0.7	
V_{OH}	Output Voltage HIGH	$I_{OH} = -33\text{ mA}$ $T_A = 0^\circ\text{C to } +70^\circ\text{C}$	3.0			V
V_{OL}	Output Voltage LOW	$I_{OL} = 33\text{ mA}$ $T_A = 0^\circ\text{C to } +70^\circ\text{C}$			2.0	V
V_{IC}	Input Clamp Voltage	$I_I = -18\text{ mA}$			-1.5	V
$ V_{OD1} $	Differential Output Voltage	$I_O = 0\text{ mA}$			6.0	V
$ V_{OD2} $	Differential Output Voltage	$R_L = 54\Omega$, Figure 1 $T_A = -55^\circ\text{C}$	1.2	2.0		V
			1.5			
		$R_L = 100\Omega$, Figure 1	2.0	2.3		
V_{OD}	Differential Output Voltage	Figure 2 $T_A = 0^\circ\text{C to } +70^\circ\text{C}$	1.0			V
$\Delta V_{OD} $	Change in Magnitude of Differential Output Voltage (Note 5)	$R_L = 54\Omega$ or 100Ω , Figure 1 $-40^\circ\text{C to } +125^\circ\text{C}$			± 0.2	V
		$-55^\circ\text{C to } +125^\circ\text{C}$			± 0.4	V
V_{OC}	Common Mode Output Voltage (Note 6)	$R_L = 54\Omega$ or 100Ω , Figure 1			3.0	V
$\Delta V_{OC} $	Change in Magnitude of Common Mode Output Voltage (Note 5)	$R_L = 54\Omega$ or 100Ω , Figure 1			± 0.2	V
I_O	Output Current with Power Off	$V_{CC} = 0\text{V}$, $V_O = -7.0\text{V to } +12\text{V}$			± 50	μA
I_{OZ}	High Impedance State Output Current	$V_O = -7.0\text{V to } +12\text{V}$		± 20	± 50	μA
I_{IH}	Input Current HIGH	$V_I = 2.4\text{V}$			20	μA
I_{IL}	Input Current LOW	$V_I = 0.4\text{V}$			-50	μA
I_{OS}	Short Circuit Output Current (Note 7)	$V_O = -7.0\text{V}$			-250	mA
		$V_O = 0\text{V}$			-150	
		$V_O = V_{CC}$			150	
		$V_O = +12\text{V}$			250	
I_{CC}	Supply Current (All Drivers)	No Load	Outputs Enabled		50	mA
I_{CCX}			Outputs Disabled		30	

COMMERCIAL

Switching Characteristics

$V_{CC} = 5.0V$, $T_A = 25^\circ C$

Symbol	Parameter	Conditions	Min	Typ	Max	Units
t_{DD}	Differential Output Delay Time	$R_L = 60\Omega$, <i>Figure 3</i>		15	20	ns
t_{TD}	Differential Output Transition Time			15	22	ns
t_{PLH}	Propagation Delay Time, Low-to-High Level Output	$R_L = 27\Omega$, <i>Figure 4</i>		12	16	ns
t_{PHL}	Propagation Delay Time, High-to-Low Level Output			12	16	ns
t_{ZH}	Output Enable Time to High Level	$R_L = 110\Omega$, <i>Figure 4</i>		25	32	ns
t_{ZL}	Output Enable Time to Low Level	$R_L = 110\Omega$, <i>Figure 6</i>		25	32	ns
t_{HZ}	Output Disable Time from High Level	$R_L = 110\Omega$, <i>Figure 5</i>		25	30	ns
t_{LZ}	Output Disable Time from Low Level	$R_L = 110\Omega$, <i>Figure 6</i>		20	25	ns
t_{LZL}	Output Disable Time from Low Level with Load Resistor to GND (Note 8)	<i>Figure 6</i>		300		ns
t_{SKEW}	Driver Output to Output	$R_L = 60\Omega$		1.0	4.0	ns

Note 2: "Absolute Maximum Ratings" are those values beyond which the safety of the device cannot be guaranteed. They are not meant to imply that the devices should be operated at these limits. The tables of "Electrical Characteristics" provide conditions for actual device operation.

Note 3: Unless otherwise specified min/max limits apply across the $0^\circ C$ to $+70^\circ C$ range for the DS96F172C/DS96F174C. All typicals are given for $V_{CC} = 5V$ and $T_A = 25^\circ C$.

Note 4: All currents into the device pins are positive; all currents out of the device pins are negative. All voltages are reference to ground unless otherwise specified.

Note 5: $\Delta|V_{OD}|$ and $\Delta|V_{OC}|$ are the changes in magnitude of V_{OD} and V_{OC} respectively, that occur when the input is changed from a high level to a low level.

Note 6: In EIA-422A and EIA-485 standards, VOC, which is the average of the two output voltages with respect to ground, is called output offset voltage, V_{OS} .

Note 7: Only one output at a time should be shorted.

Note 8: For more information see Application Bulletin, contact Product Marketing.

Order Number: DS96F172CN
DS96F174CJ
DS96F174CN
NS Package Number J16A or N16E

MIL-STD-883C

Absolute Maximum Ratings (Note 2)

For complete Military Specifications, refer to the appropriate SMD or MDS.

Storage Temperature Range (T_{STG})	-65°C to +175°C
Lead Temperature (Soldering, 60 sec.)	300°C
Maximum Package Power Dissipation (Note 9) at 25°C	
Ceramic LCC (E)	2000 mW
Ceramic DIP (J)	1800 mW
Ceramic Flatpak (W)	1000 mW
Supply Voltage	7.0V
Enable Input Voltage	5.5V

Recommended Operating Conditions

	Min	Typ	Max	Units
Supply Voltage (V_{CC})				
DS96F172M/DS96F174M	4.50	5.0	5.50	V
Common Mode	-7.0		+12.0	V
Output Voltage (V_{OC})				
Output Current HIGH (I_{OH})			-60	mA
Output Current LOW (I_{OL})			60	mA
Operating Temperature (T_A)				
DS96F172M/DS96F174M	-55		+125	

Note 9: Above $T_A = 25^\circ\text{C}$, derate "E" package 13.4, "J" package 12.5, "W" package 7.1 mW/°C

Electrical Characteristics (Notes 3, 4)

Over recommended supply voltage and operating temperature range unless otherwise specified

Symbol	Parameter	Conditions	Min	Max	Units
V_{IH}	Input Voltage HIGH		2.0		V
V_{IL}	Input Voltage LOW	$T_A = 25^\circ\text{C}$		0.8	V
		$T_A = -55^\circ\text{C}$, or $+125^\circ\text{C}$		0.7	V
V_{IC}	Input Clamp Voltage	$I_I = -18\text{ mA}$		-1.5	V
$ V_{OD1} $	Differential Output Voltage	$I_O = 0\text{ mA}$		6.0	V
$ V_{OD2} $	Differential Output Voltage	$R_L = 54\Omega$, $V_{CC} = 4.5\text{V}$	$T_A = -55^\circ\text{C}$	1.2	V
		Figure 1	$T_A = 25^\circ\text{C}$, or $+125^\circ\text{C}$	1.5	
			$R_L = 100\Omega$, $V_{CC} = 4.5\text{V}$, Figure 1		
$\Delta V_{OD} $	Change in Magnitude of Differential Output Voltage (Note 5)	$R_L = 54\Omega$ or 100Ω , $V_{CC} = 4.5\text{V}$, Figure 1	$T_A = 25^\circ\text{C}$, or $+125^\circ\text{C}$	± 0.2	V
			-55°C	± 0.4	V
V_{OC}	Common Mode Output Voltage (Note 6)	$R_L = 54\Omega$ or 100Ω , Figure 1		3.0	V
$\Delta V_{OC} $	Change in Magnitude of Common Mode Output Voltage (Note 5)	$R_L = 54\Omega$ or 100Ω , $V_{CC} = 4.5\text{V}$, Figure 1		± 0.2	V
I_O	Output Current with Power Off	$V_{CC} = 0\text{V}$, $V_O = -7.0\text{V}$ to $+12\text{V}$		± 50	μA
I_{OZ}	High Impedance State Output Current	$V_O = -7.0\text{V}$ to $+12\text{V}$		± 50	μA
I_{IH}	Input Current HIGH	$V_I = 2.4\text{V}$		20	μA
I_{IL}	Input Current LOW	$V_I = 0.4\text{V}$		-50	μA
I_{OS}	Short Circuit Output Current (Note 7)	$V_O = -7.0\text{V}$		-250	mA
		$V_O = 0\text{V}$		-150	
		$V_O = V_{CC}$		150	
		$V_O = +12\text{V}$		250	
I_{CC}	Supply Current (All Drivers)	No Load	Outputs Enabled	50	mA
			Outputs Disabled	30	

MIL-STD-883C

Switching Characteristics

$V_{CC} = 5.0V$

Symbol	Parameter	Conditions	$T_A = 25^\circ C$		$T_A = 55^\circ C$	$T_A = 125^\circ C$	Units
			Typ	Max	Max	Max	
t_{DD}	Differential Output Delay Time	$R_L = 60\Omega, C_L = 15\text{ pF},$ <i>Figure 3</i>	15	22	30	30	ns
t_{TD}	Differential Output Transition Time		15	22	40	40	ns
t_{PLH}	Propagation Delay Time, Low-to-High Level Output	$R_L = 27\Omega, C_L = 15\text{ pF},$ <i>Figure 4</i>	12	16	25	25	ns
t_{PHL}	Propagation Delay Time, High-to-Low Level Output		12	16	25	25	ns
t_{ZH}	Output Enable Time to High Level	$R_L = 110\Omega, \text{Figure 5}$	25	32	40	40	ns
t_{ZL}	Output Enable Time to Low Level	$R_L = 110\Omega, \text{Figure 6}$	25	35	100	100	ns
t_{HZ}	Output Disable Time from High Level	$R_L = 110\Omega, \text{Figure 5},$ Note 13	25	30	80	80	ns
t_{LZ}	Output Disable Time from Low Level	$R_L = 110\Omega, \text{Figure 6}$	20	25	40	40	ns
t_{LZL}	Output Disable Time from Low Level with Load Resistor to GND (Note 12)	<i>Figure 6</i>	300				ns
t_{SKEW}	Driver Output to Output	$R_L = 60\Omega$	1.0	4.0	10	10	ns

SMD Numbers: DS96F172MJ/883 5962-9076501MEA
DS96F174MJ/883 5962-9076502MEA

DS96F172ME/883 5962-9076501M2A
DS96F174MW/883 5962-9076502MFA
DS96F174ME/883 5962-9076502M2A

Order Number: DS96F172MJ/883, DS96F174MJ/883
NS Package Number J16A
DS96F172ME/883, DS96F174ME/883
NS Package Number E20A
DS96F172MW-MIL, DS96F174MW/883
NS Package Number W16A

For Complete Military Product Specifications, refer to the appropriate SMD or MDS.

Parameter Measurement Information

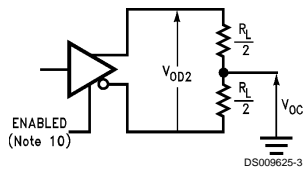

FIGURE 1. Differential and Common Mode Output Voltage

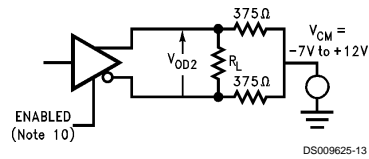
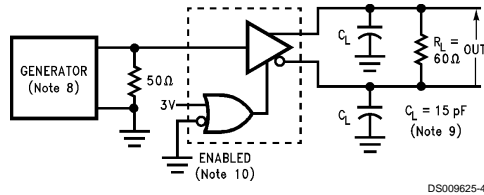

FIGURE 2. Differential Output Voltage with Varying Common Mode Voltage

Parameter Measurement Information (Continued)



DS009625-4

FIGURE 3. Differential Output Delay and Transition Times

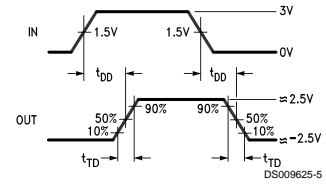

DS009625-5

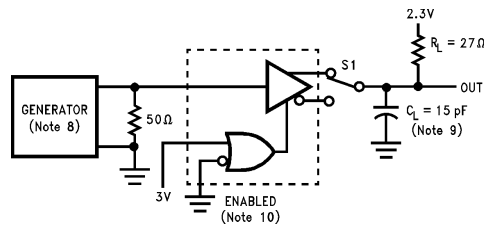

DS009625-6

FIGURE 4. Propagation Delay Times

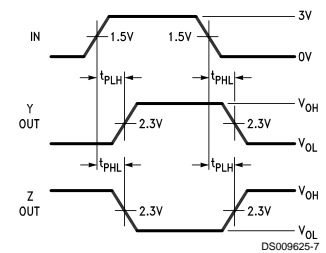

DS009625-7

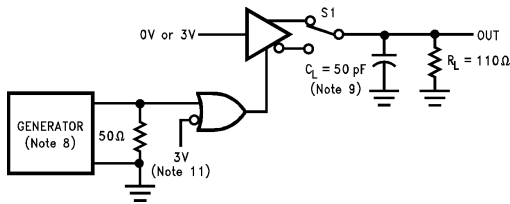

DS009625-8

FIGURE 5. t_{ZH} and t_{HZ}

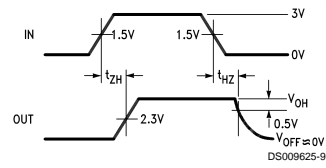

DS009625-9

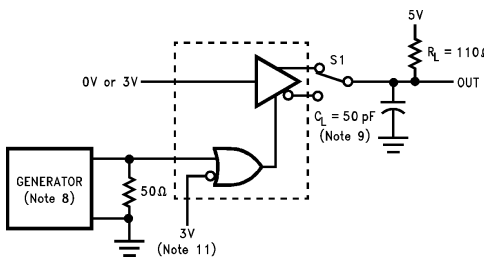

DS009625-10

FIGURE 6. t_{ZL} , t_{LZ} , t_{LZL}

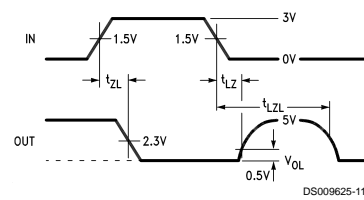

DS009625-11

Note 10: The input pulse is supplied by a generator having the following characteristics: $f = 1.0$ MHz, duty cycle = 50%, $t_r \leq 5.0$ ns, $t_f \leq 5.0$ ns, $Z_0 = 50\Omega$.

Note 11: C_L includes probe and jig capacitance.

Note 12: DS96F172 with active high and active low Enables is shown. DS96F174 has active high Enable only.

Note 13: To test the active low Enable \bar{E} of DS96F172 ground E and apply an inverted waveform to \bar{E} . DS96F174 has active high Enable only.

Note 14: For more information see Application Bulletin, Contact Product Marketing.

Note 15: Not tested for DS96F172MW-MIL device.

Typical Application

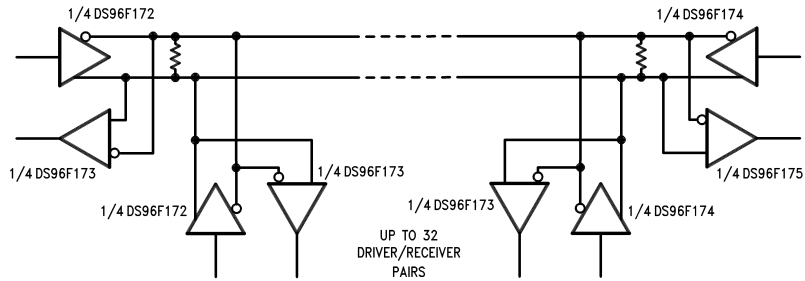

DS009625-12

The line length should be terminated at both ends in its characteristic impedance.
Stub lengths off the main line should be kept as short as possible.

Connection Diagrams

16-Lead Ceramic Dual-In-Line Package NS Package Number J16A

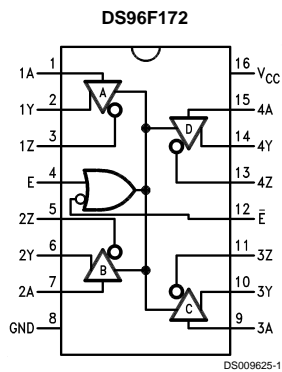

Top View

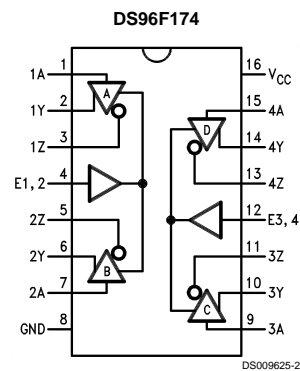

Top View

20-Lead Ceramic Leadless Chip Carrier NS Package Number E20A

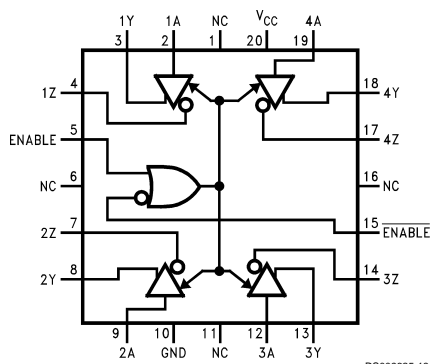

Top View

NC = No connection

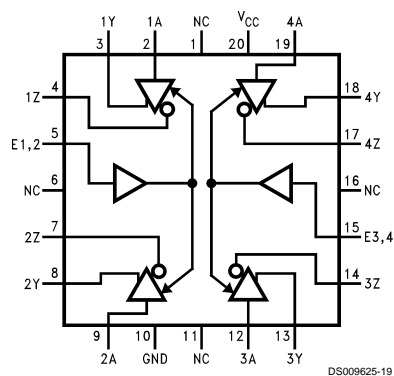

Top View

Connection Diagrams (Continued)

**16-Lead Ceramic Flatpak
NS Package Number W16A**

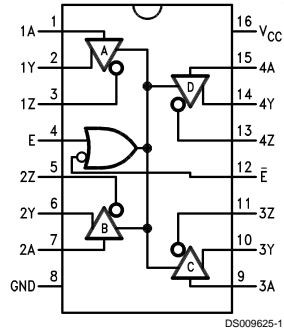

Top View

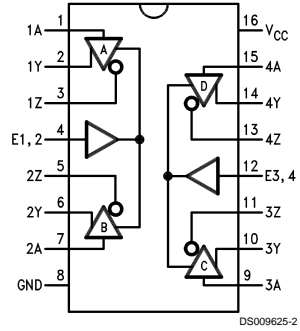

Top View

Order Numbers are located at the end of the respective Electrical Tables.

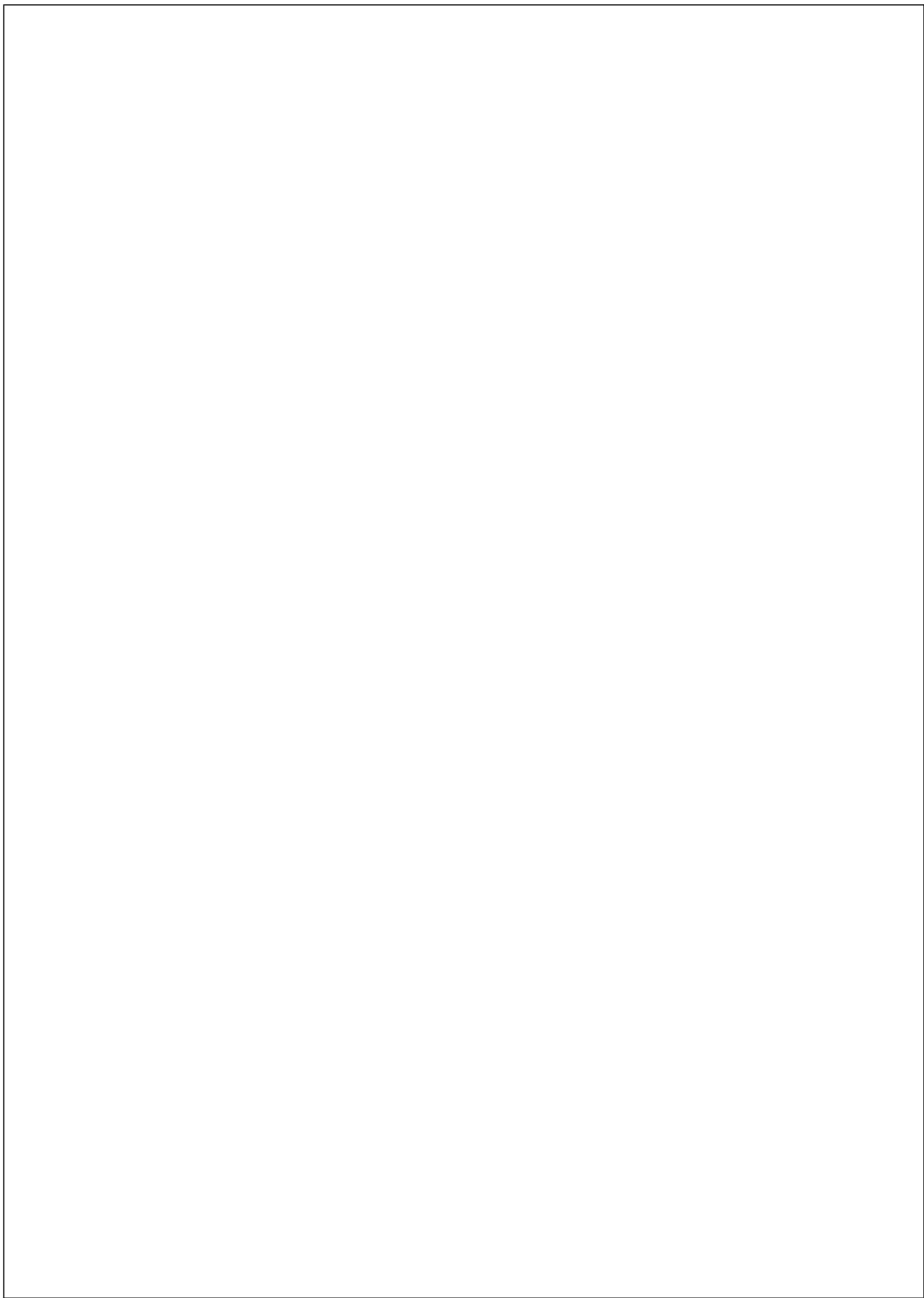

Physical Dimensions inches (millimeters) unless otherwise noted

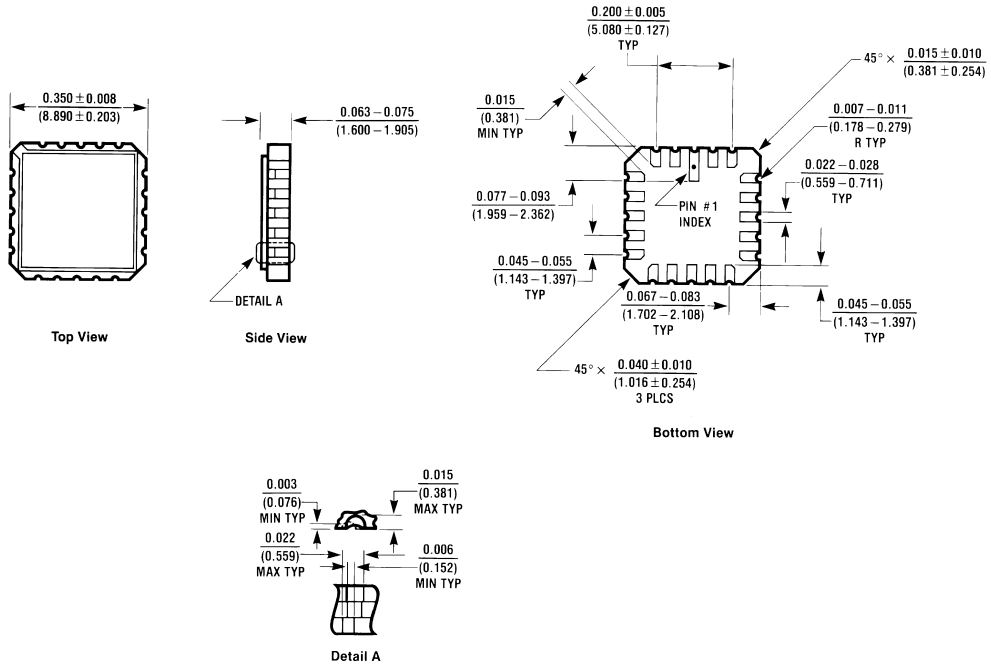

E20A (REV D)

20-Lead Ceramic Leadless Chip Carrier (E)
Order Number DS96F172ME/883, DS96F174ME/883
NS Package Number E20A

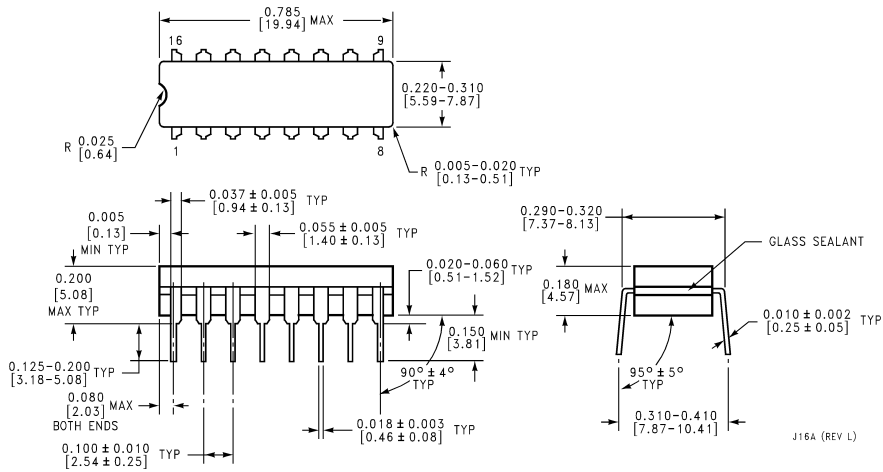

J16A (REV L)

16-Lead Ceramic Dual-In-Line Package (J)
Order Number DS96F172MJ/883,
DS96F174CJ, DS96F174MJ/883
NS Package Number J16A

Physical Dimensions inches (millimeters) unless otherwise noted (Continued)

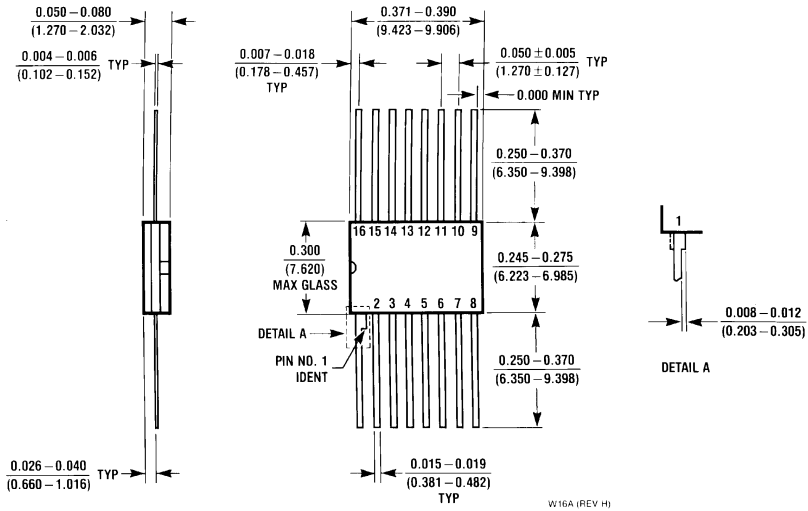

16-Lead Ceramic Flatpack (W)
Order Number DS96F172MW/883, DS96F174MW/883
NS Package Number W16A

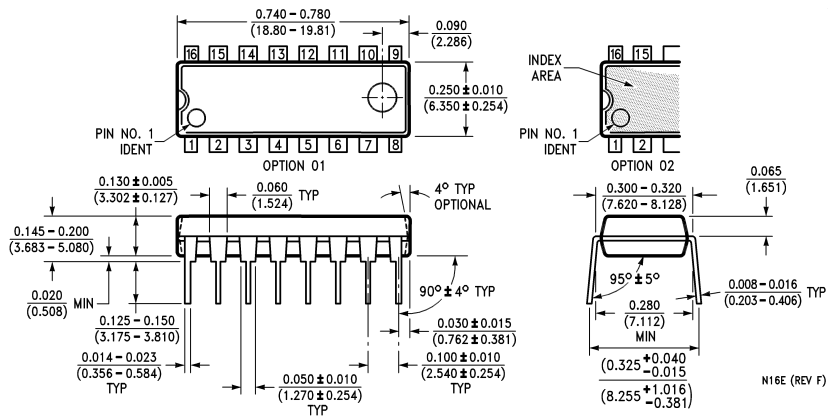

Molded Dual-In-Line Package (N)
Order Number DS96F172CN, or DS96F174CN
NS Package Number N16E

LIFE SUPPORT POLICY

NATIONAL'S PRODUCTS ARE NOT AUTHORIZED FOR USE AS CRITICAL COMPONENTS IN LIFE SUPPORT DEVICES OR SYSTEMS WITHOUT THE EXPRESS WRITTEN APPROVAL OF THE PRESIDENT OF NATIONAL SEMICONDUCTOR CORPORATION. As used herein:

1. Life support devices or systems are devices or systems which, (a) are intended for surgical implant into the body, or (b) support or sustain life, and whose failure to perform when properly used in accordance with instructions for use provided in the labeling, can be reasonably expected to result in a significant injury to the user.
2. A critical component in any component of a life support device or system whose failure to perform can be reasonably expected to cause the failure of the life support device or system, or to affect its safety or effectiveness.



National Semiconductor Corporation
Americas
Tel: 1-800-272-9959
Fax: 1-800-737-7018
Email: support@nsc.com

www.national.com

National Semiconductor Europe
Fax: +49 (0) 1 80-530 85 86
Email: europe.support@nsc.com
Deutsch Tel: +49 (0) 1 80-530 85 85
English Tel: +49 (0) 1 80-532 78 32
Français Tel: +49 (0) 1 80-532 93 58
Italiano Tel: +49 (0) 1 80-534 16 80

National Semiconductor Asia Pacific Customer Response Group
Tel: 65-2544466
Fax: 65-2504466
Email: sea.support@nsc.com

National Semiconductor Japan Ltd.
Tel: 81-3-5620-6175
Fax: 81-3-5620-6179