

LM108A/LM208A/LM308A Operational Amplifiers

General Description

The LM108/LM108A series are precision operational amplifiers having specifications about a factor of ten better than FET amplifiers over their operating temperature range. In addition to low input currents, these devices have extremely low offset voltage, making it possible to eliminate offset adjustments, in most cases, and obtain performance approaching chopper stabilized amplifiers.

The devices operate with supply voltages from $\pm 2V$ to $\pm 18V$ and have sufficient supply rejection to use unregulated supplies. Although the circuit is interchangeable with and uses the same compensation as the LM101A, an alternate compensation scheme can be used to make it particularly insensitive to power supply noise and to make supply bypass capacitors unnecessary.

The low current error of the LM108A series makes possible many designs that are not practical with conventional amplifiers. In fact, it operates from $10\text{ M}\Omega$ source resistances,

introducing less error than devices like the 709 with $10\text{ k}\Omega$ sources. Integrators with drifts less than $500\ \mu\text{V}/\text{sec}$ and analog time delays in excess of one hour can be made using capacitors no larger than $1\ \mu\text{F}$.

The LM208A is identical to the LM108A, except that the LM208A has its performance guaranteed over a -25°C to $+85^\circ\text{C}$ temperature range, instead of -55°C to $+125^\circ\text{C}$. The LM308A devices have slightly-relaxed specifications and performances over a 0°C to $+70^\circ\text{C}$ temperature range.

Features

- Offset voltage guaranteed less than 0.5 mV
- Maximum input bias current of 3.0 nA over temperature
- Offset current less than 400 pA over temperature
- Supply current of only $300\ \mu\text{A}$, even in saturation
- Guaranteed $5\ \mu\text{V}/^\circ\text{C}$ drift

Compensation Circuits

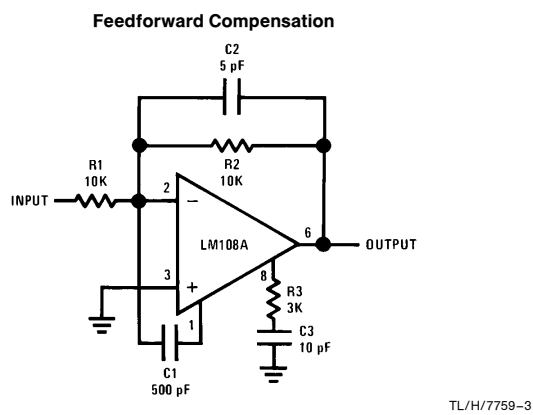
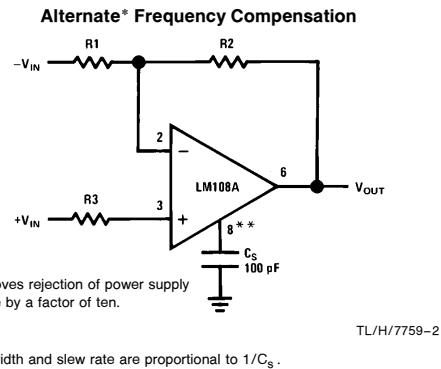
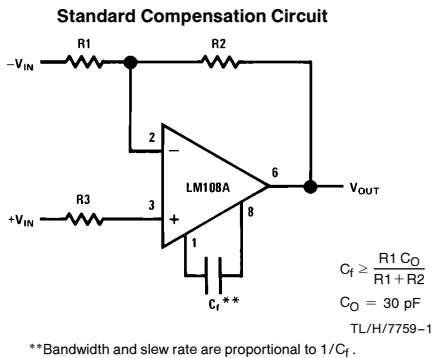

LM108A/LM208A Absolute Maximum Ratings

If Military/Aerospace specified devices are required, please contact the National Semiconductor Sales Office/Distributors for availability and specifications. (Note 5)

Supply Voltage	±20V
Power Dissipation (Note 1)	500 mW
Differential Input Current (Note 2)	±10 mA
Input Voltage (Note 3)	±15V
Output Short-Circuit Duration	Continuous
Operating Free Air Temperature Range	
LM108A	−55°C to +125°C
LM208A	−25°C to +85°C

Storage Temperature Range	−65°C to +150°C
Lead Temperature (Soldering, 10 sec.) (DIP)	260°C
Soldering Information	
Dual-In-Line Package	
Soldering (10 sec.)	260°C
Small Outline Package	
Vapor Phase (60 sec.)	215°C
Infrared (15 sec.)	220°C
See An-450 "Surface Mounting Methods and Their Effect on Product Reliability" for other methods of soldering surface mount devices.	
ESD Tolerance (Note 6)	2000V

Electrical Characteristics (Note 4)

Parameter	Conditions	Min	Typ	Max	Units
Input Offset Voltage	$T_A = 25^\circ\text{C}$		0.3	0.5	mV
Input Offset Current	$T_A = 25^\circ\text{C}$		0.05	0.2	nA
Input Bias Current	$T_A = 25^\circ\text{C}$		0.8	2.0	nA
Input Resistance	$T_A = 25^\circ\text{C}$	30	70		MΩ
Supply Current	$T_A = 25^\circ\text{C}$		0.3	0.6	mA
Large Signal Voltage Gain	$T_A = 25^\circ\text{C}$, $V_S = \pm 15\text{V}$, $V_{OUT} = \pm 10\text{V}$, $R_L \geq 10\text{ k}\Omega$	80	300		V/mV
Input Offset Voltage				1.0	mV
Average Temperature Coefficient of Input Offset Voltage			1.0	5.0	$\mu\text{V}/^\circ\text{C}$
Input Offset Current				0.4	nA
Average Temperature Coefficient of Input Offset Current			0.5	2.5	$\text{pA}/^\circ\text{C}$
Input Bias Current				3.0	nA
Supply Current	$T_A = 125^\circ\text{C}$		0.15	0.4	mA
Large Signal Voltage Gain	$V_S = \pm 15\text{V}$, $V_{OUT} = \pm 10\text{V}$, $R_L \geq 10\text{ k}\Omega$	40			V/mV
Output Voltage Swing	$V_S = \pm 15\text{V}$, $R_L = 10\text{ k}\Omega$	±13	±14		V
Input Voltage Range	$V_S = \pm 15\text{V}$	±13.5			V
Common Mode Rejection Ratio		96	110		dB
Supply Voltage Rejection Ratio		96	110		dB

Note 1: The maximum junction temperature of the LM108A is 150°C, while that of the LM208A is 100°C. For operating at elevated temperatures, devices in the H08 package must be derated based on a thermal resistance of 160°C/W, junction to ambient, or 20°C/W, junction to case. The thermal resistance of the dual-in-line package is 100°C/W, junction to ambient.

Note 2: The inputs are shunted with back-to-back diodes for overvoltage protection. Therefore, excessive current will flow if a differential input voltage in excess of 1V is applied between the inputs unless some limiting resistance is used.

Note 3: For supply voltages less than ±15V, the absolute maximum input voltage is equal to the supply voltage.

Note 4: These specifications apply for $\pm 5\text{V} \leq V_S \leq \pm 20\text{V}$ and $-55^\circ\text{C} \leq T_A \leq 125^\circ\text{C}$, unless otherwise specified. With the LM208A, however, all temperature specifications are limited to $-25^\circ\text{C} \leq T_A \leq 85^\circ\text{C}$.

Note 5: Refer to RETS108AX for LM108AH and LM108AJ-8 military specifications.

Note 6: Human body model, 1.5 kΩ in series with 100 pF.

LM308A Absolute Maximum Ratings

If Military/Aerospace specified devices are required, please contact the National Semiconductor Sales Office/Distributors for availability and specifications.

Supply Voltage	±18V
Power Dissipation (Note 1)	500 mW
Differential Input Current (Note 2)	±10 mA
Input Voltage (Note 3)	±15V
Output Short-Circuit Duration	Continuous
Operating Temperature Range	0°C to +70°C
Storage Temperature Range	-65°C to +150°C
H-Package Lead Temperature (Soldering, 10 sec.)	300°C

Lead Temperature (Soldering, 10 sec.) (DIP)	260°C
Soldering Information	
Dual-In-Line Package	
Soldering (10 sec.)	260°C
Small Outline Package	
Vapor phase (60 sec.)	215°C
Infrared (15 sec.)	220°C
See An-450 "Surface Mounting Methods and Their Effect on Product Reliability" for other methods of soldering surface mount devices.	
ESD rating to be determined.	

Electrical Characteristics (Note 4)

Parameter	Conditions	Min	Typ	Max	Units
Input Offset Voltage	$T_A = 25^\circ\text{C}$		0.3	0.5	mV
Input Offset Current	$T_A = 25^\circ\text{C}$		0.2	1	nA
Input Bias Current	$T_A = 25^\circ\text{C}$		1.5	7	nA
Input Resistance	$T_A = 25^\circ\text{C}$	10	40		M Ω
Supply Current	$T_A = 25^\circ\text{C}, V_S = \pm 15\text{V}$		0.3	0.8	mA
Large Signal Voltage Gain	$T_A = 25^\circ\text{C}, V_S = \pm 15\text{V}, V_{OUT} = \pm 10\text{V}, R_L \geq 10\text{ k}\Omega$	80	300		V/mV
Input Offset Voltage	$V_S = \pm 15\text{V}, R_S = 100\Omega$			0.73	mV
Average Temperature Coefficient of Input Offset Voltage	$V_S = \pm 15\text{V}, R_S = 100\Omega$		2.0	5.0	$\mu\text{V}/^\circ\text{C}$
Input Offset Current				1.5	nA
Average Temperature Coefficient of Input Offset Current			2.0	10	$\text{pA}/^\circ\text{C}$
Input Bias Current				10	nA
Large Signal Voltage Gain	$V_S = \pm 15\text{V}, V_{OUT} = \pm 10\text{V}, R_L \geq 10\text{ k}\Omega$	60			V/mV
Output Voltage Swing	$V_S = \pm 15\text{V}, R_L = 10\text{ k}\Omega$	±13	±14		V
Input Voltage Range	$V_S = \pm 15\text{V}$	±14			V
Common Mode Rejection Ratio		96	110		dB
Supply Voltage Rejection Ratio		96	110		dB

Note 1: The maximum junction temperature of the LM308A is 85°C. For operating at elevated temperatures, devices in the H08 package must be derated based on a thermal resistance of 160°C/W, junction to ambient, or 20°C/W, junction to case. The thermal resistance of the dual-in-line package is 100°C/W, junction to ambient.

Note 2: The inputs are shunted with back-to-back diodes for overvoltage protection. Therefore, excessive current will flow if a differential input voltage in excess of 1V is applied between the inputs unless some limiting resistance is used.

Note 3: For supply voltages less than ±15V, the absolute maximum input voltage is equal to the supply voltage.

Note 4: These specifications apply for $\pm 5\text{V} \leq V_S \leq \pm 15\text{V}$ and $0^\circ\text{C} \leq T_A \leq +70^\circ\text{C}$, unless otherwise specified.

Typical Applications

Sample and Hold

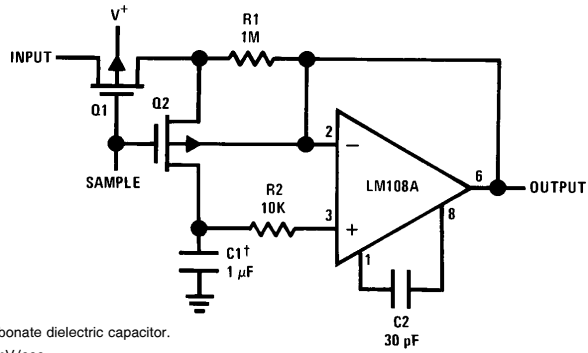

†Teflon, polyethylene or polycarbonate dielectric capacitor.

Worst case drift less than 2.5 mV/sec.

TL/H/7759-4

High Speed Amplifier with Low Drift and Low Input Current

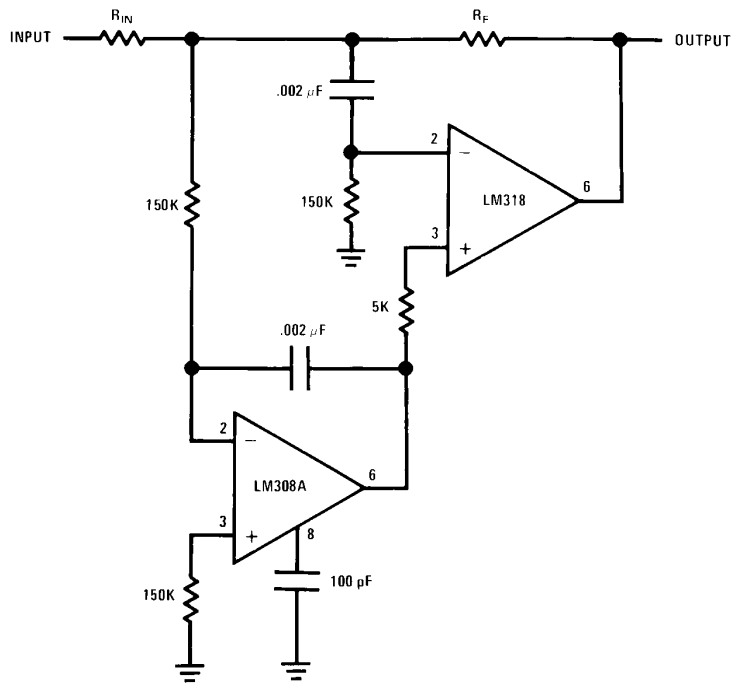

TL/H/7759-5

Application Hints

A very low drift amplifier poses some uncommon application and testing problems. Many sources of error can cause the apparent circuit drift to be much higher than would be predicted.

Thermocouple effects caused by temperature gradient across dissimilar metals are perhaps the worst offenders. Only a few degrees gradient can cause hundreds of microvolts of error. The two places this shows up, generally, are the package-to-printed circuit board interface and temperature gradients across resistors. Keeping package leads short and the two input leads close together helps greatly.

Resistor choice as well as physical placement is important for minimizing thermocouple effects. Carbon, oxide film and some metal film resistors can cause large thermocouple errors. Wirewound resistors of evanohm or manganin are best since they only generate about $2 \mu\text{V}/^\circ\text{C}$ referenced to copper. Of course, keeping the resistor ends at the same temperature is important. Generally, shielding a low drift stage electrically and thermally will yield good results.

Resistors can cause other errors besides gradient generated voltages. If the gain setting resistors do not track with temperature a gain error will result. For example, a gain of 1000 amplifier with a constant 10 mV input will have a 10V output. If the resistors mistrack by 0.5% over the operating temperature range, the error at the output is 50 mV. Referred to input, this is a $50 \mu\text{V}$ error. All of the gain fixing resistor should be the same material.

Testing low drift amplifiers is also difficult. Standard drift testing technique such as heating the device in an oven and having the leads available through a connector, thermoprobe, or the soldering iron method—do not work. Thermal gradients cause much greater errors than the amplifier drift. Coupling microvolt signal through connectors is especially bad since the temperature difference across the connector can be 50°C or more. The device under test along with the gain setting resistor should be isothermal.

Schematic Diagram

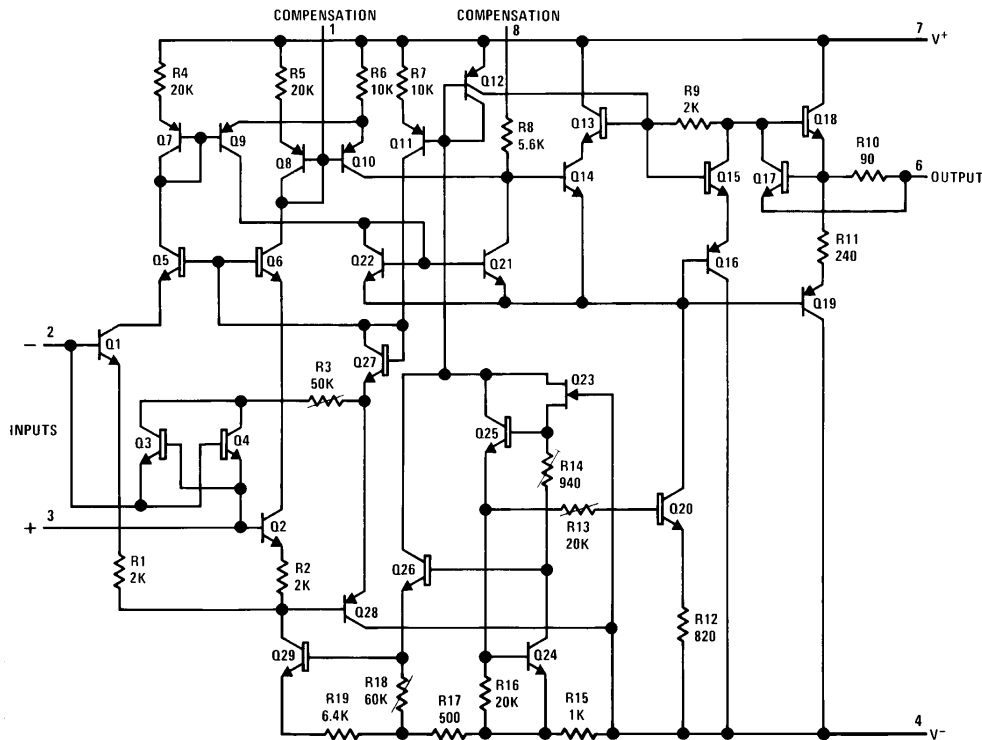

TL/H/7759-6

Connection Diagrams

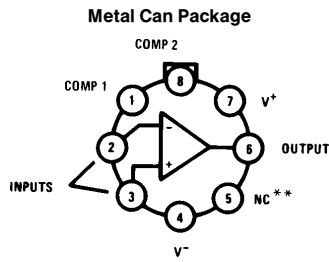

TL/H/7759-7

Pin 4 is connected to the case.

**Unused pin (no internal connection) to allow for input anti-leakage guard ring on printed circuit board layout.

Order Number LM108AH, LM208AH or LM208AH
See NS Package Number H08C

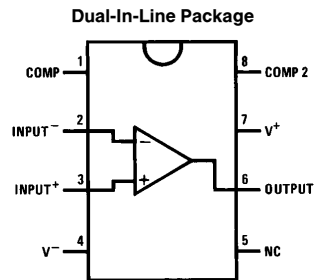

TL/H/7759-8

Top View

Order Number LM108AJ-8, LM208AJ-8, LM308AJ-8,
LM308AM or LM308AN
See NS Package Number J08A, M08A or N08E

Physical Dimensions inches (millimeters)

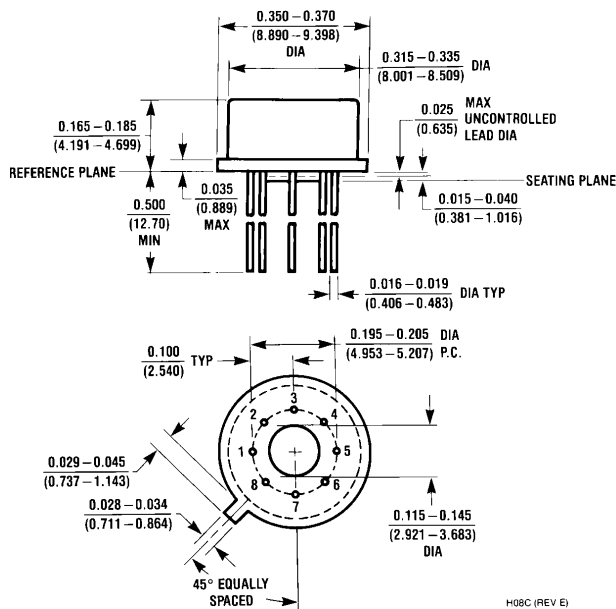

Metal Can Package (H)
Order Number LM108AH, LM208AH or LM308AH
NS Package Number H08C

Physical Dimensions inches (millimeters) (Continued)

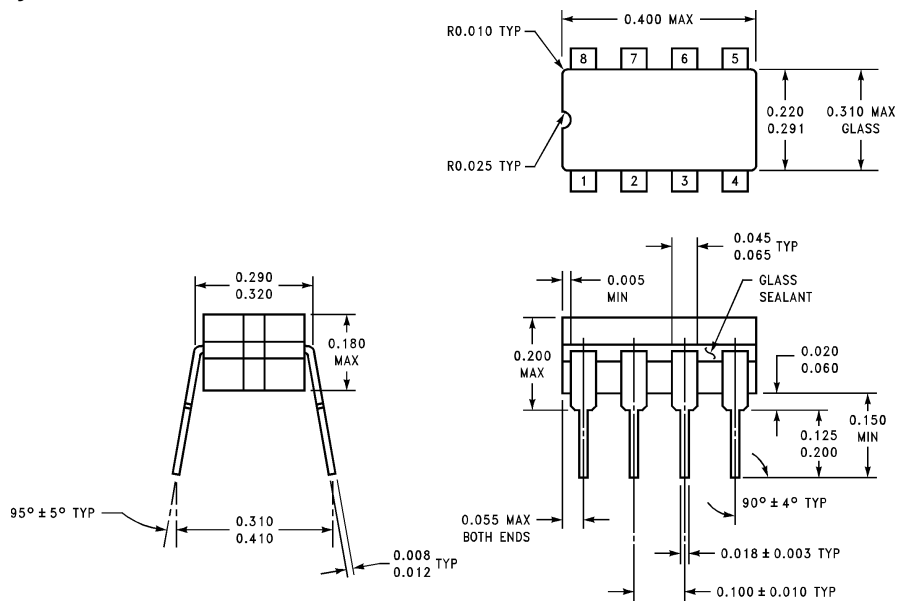

J08A (REV K)

Ceramic Dual-In-Line Package (J)
Order Number LM108AJ-8, LM208AJ-8 or LM308AJ-8
NS Package Number J08A

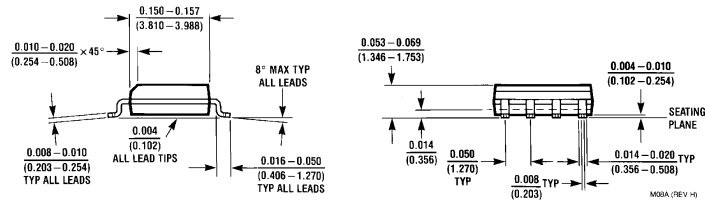
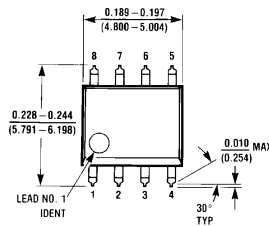

M08A (REV H)

S.O. Package (M)
Order Number LM308AM
NS Package Number M08A

Physical Dimensions inches (millimeters) (Continued)

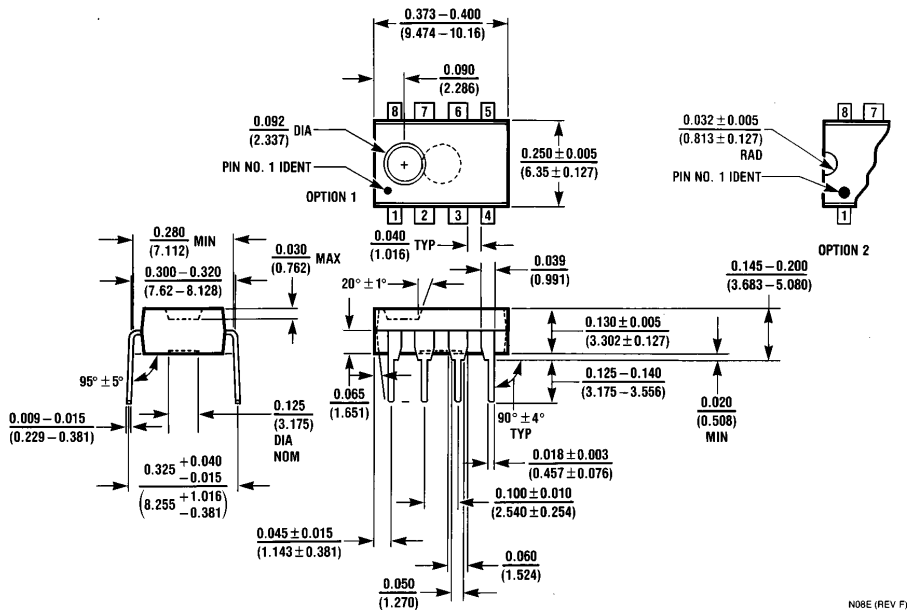

Molded Dual-In-Line Package (N)
Order Number LM308AN
NS Package Number N08E

N08E (REV F)

LIFE SUPPORT POLICY

NATIONAL'S PRODUCTS ARE NOT AUTHORIZED FOR USE AS CRITICAL COMPONENTS IN LIFE SUPPORT DEVICES OR SYSTEMS WITHOUT THE EXPRESS WRITTEN APPROVAL OF THE PRESIDENT OF NATIONAL SEMICONDUCTOR CORPORATION. As used herein:

1. Life support devices or systems are devices or systems which, (a) are intended for surgical implant into the body, or (b) support or sustain life, and whose failure to perform, when properly used in accordance with instructions for use provided in the labeling, can be reasonably expected to result in a significant injury to the user.
2. A critical component is any component of a life support device or system whose failure to perform can be reasonably expected to cause the failure of the life support device or system, or to affect its safety or effectiveness.



National Semiconductor Corporation
 1111 West Bardin Road
 Arlington, TX 76017
 Tel: 1(800) 272-9959
 Fax: 1(800) 737-7018

National Semiconductor Europe
 Fax: (+49) 0-180-530 85 86
 Email: cnjwge@tevm2.nsc.com
 Deutsch Tel: (+49) 0-180-530 85 85
 English Tel: (+49) 0-180-532 78 32
 Français Tel: (+49) 0-180-532 93 58
 Italiano Tel: (+49) 0-180-534 16 80

National Semiconductor Hong Kong Ltd.
 13th Floor, Straight Block,
 Ocean Centre, 5 Canton Road,
 Tsimshatsui, Kowloon
 Hong Kong
 Tel: (852) 2737-1600
 Fax: (852) 2736-9960

National Semiconductor Japan Ltd.
 Tel: 81-043-299-2309
 Fax: 81-043-299-2408

National does not assume any responsibility for use of any circuitry described, no circuit patent licenses are implied and National reserves the right at any time without notice to change said circuitry and specifications.