

LM129/LM329 Precision Reference

General Description

The LM129 and LM329 family are precision multi-current temperature-compensated 6.9V zener references with dynamic impedances a factor of 10 to 100 less than discrete diodes. Constructed in a single silicon chip, the LM129 uses active circuitry to buffer the internal zener allowing the device to operate over a 0.5 mA to 15 mA range with virtually no change in performance. The LM129 and LM329 are available with selected temperature coefficients of 0.001, 0.002, 0.005 and 0.01%/°C. These references also have excellent long term stability and low noise.

A new subsurface breakdown zener used in the LM129 gives lower noise and better long-term stability than conventional IC zeners. Further the zener and temperature compensating transistor are made by a planar process so they are immune to problems that plague ordinary zeners. For example, there is virtually no voltage shift in zener voltage due to temperature cycling and the device is insensitive to stress on the leads.

The LM129 can be used in place of conventional zeners with improved performance. The low dynamic impedance simplifies biasing and the wide operating current allows the replacement of many zener types.

The LM129 is packaged in a 2-lead TO-46 package and is rated for operation over a -55°C to +125°C temperature range. The LM329 for operation over 0°C to 70°C is available in both a hermetic TO-46 package and a TO-92 epoxy package.

Features

- 0.6 mA to 15 mA operating current
- 0.6Ω dynamic impedance at any current
- Available with temperature coefficients of 0.001%/°C
- 7μV wideband noise
- 5% initial tolerance
- 0.002% long term stability
- Low cost
- Subsurface zener

Connection Diagrams

Metal Can Package (TO-46)

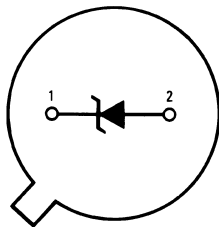

DS005714-6

Pin 2 is electrically connected to case

Bottom View

**Order Number LM129AH, LM129AH/883, LM129BH,
LM129BH/883, LM129CH, LM329AH, LM329BH,
LM329CH or LM329DH
See NS Package H02A**

Plastic Package (TO-92)

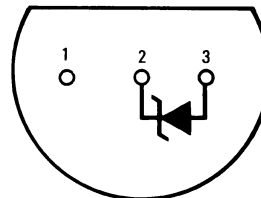

DS005714-4

Bottom View

**Order Number LM329BZ,
LM329CZ or LM329DZ
See NS Package Z03A**

Typical Applications

Simple Reference

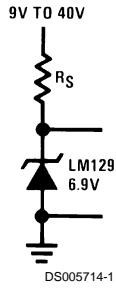

Absolute Maximum Ratings (Note 1)

If Military/Aerospace specified devices are required, please contact the National Semiconductor Sales Office/Distributors for availability and specifications. (Note 3)

Reverse Breakdown Current	30 mA
Forward Current	2 mA

Operating Temperature Range

LM129	-55°C to +125°C
LM329	0°C to +70°C

Storage Temperature Range

-55°C to +150°C

Soldering Information

TO-92 package: 10 sec.	260°C
TO-46 package: 10 sec.	300°C

Electrical Characteristics (Note 2)

Parameter	Conditions	LM129A, B, C			LM329A, B, C, D			Units
		Min	Typ	Max	Min	Typ	Max	
Reverse Breakdown Voltage	$T_A = 25^\circ\text{C}$, $0.6\text{ mA} \leq I_R \leq 15\text{ mA}$	6.7	6.9	7.2	6.6	6.9	7.25	V
Reverse Breakdown Change with Current (Note 4)	$T_A = 25^\circ\text{C}$, $0.6\text{ mA} \leq I_R \leq 15\text{ mA}$		9	14		9	20	mV
Reverse Dynamic Impedance (Note 4)	$T_A = 25^\circ\text{C}$, $I_R = 1\text{ mA}$		0.6	1		0.8	2	Ω
RMS Noise	$T_A = 25^\circ\text{C}$, $10\text{ Hz} \leq F \leq 10\text{ kHz}$		7	20		7	100	μV
Long Term Stability (1000 hours)	$T_A = 45^\circ\text{C} \pm 0.1^\circ\text{C}$, $I_R = 1\text{ mA} \pm 0.3\%$		20			20		ppm
Temperature Coefficient	$I_R = 1\text{ mA}$							
LM129A, LM329A			6	10		6	10	ppm/°C
LM129B, LM329B			15	20		15	20	ppm/°C
LM129C, LM329C			30	50		30	50	ppm/°C
LM329D						50	100	ppm/°C
Change In Reverse Breakdown Temperature Coefficient	$1\text{ mA} \leq I_R \leq 15\text{ mA}$		1			1		ppm/°C
Reverse Breakdown Change with Current	$1\text{ mA} \leq I_R \leq 15\text{ mA}$		12			12		mV
Reverse Dynamic Impedance	$1\text{ mA} \leq I_R \leq 15\text{ mA}$		0.8			1		Ω

Note 1: "Absolute Maximum Ratings" indicate limits beyond which damage to the device may occur. Operating Ratings indicate conditions for which the device is functional, but do not guarantee specific performance limits.

Note 2: These specifications apply for $-55^\circ\text{C} \leq T_A \leq +125^\circ\text{C}$ for the LM129 and $0^\circ\text{C} \leq T_A \leq +70^\circ\text{C}$ for the LM329 unless otherwise specified. The maximum junction temperature for an LM129 is 150°C and LM329 is 100°C . For operating at elevated temperature, devices in TO-46 package must be derated based on a thermal resistance of 440°C/W junction to ambient or 80°C/W junction to case. For the TO-92 package, the derating is based on 180°C/W junction to ambient with 0.4" leads from a PC board and 160°C/W junction to ambient with 0.125" lead length to a PC board.

Note 3: Refer to RETS129H for LM129 family military specifications.

Note 4: These changes are tested on a pulsed basis with a low duty-cycle. For changes versus temperature, compute in terms of tempco.

Typical Applications

Low Cost 0–25V Regulator

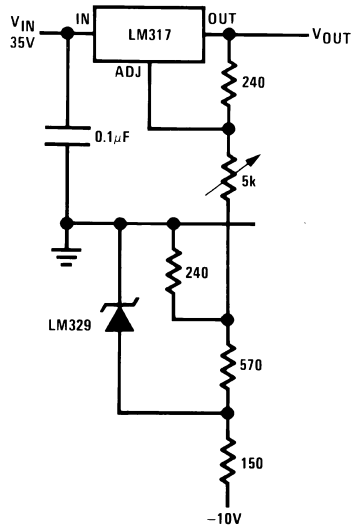

DS005714-7

Adjustable Bipolar Output Reference

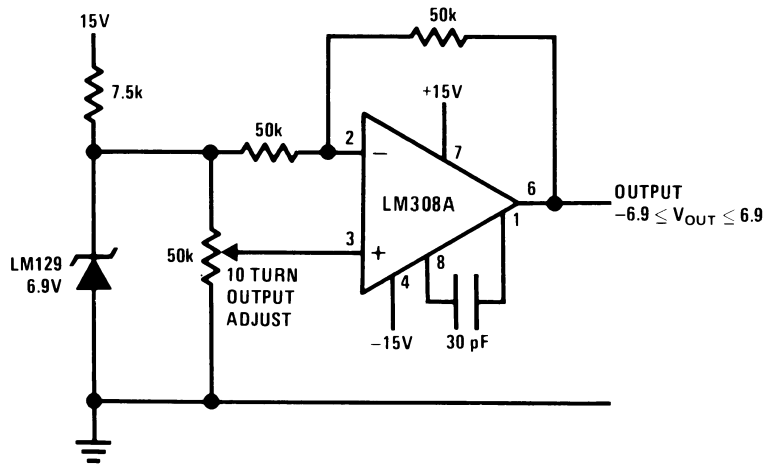

DS005714-8

Typical Applications (Continued)

0V to 20V Power Reference

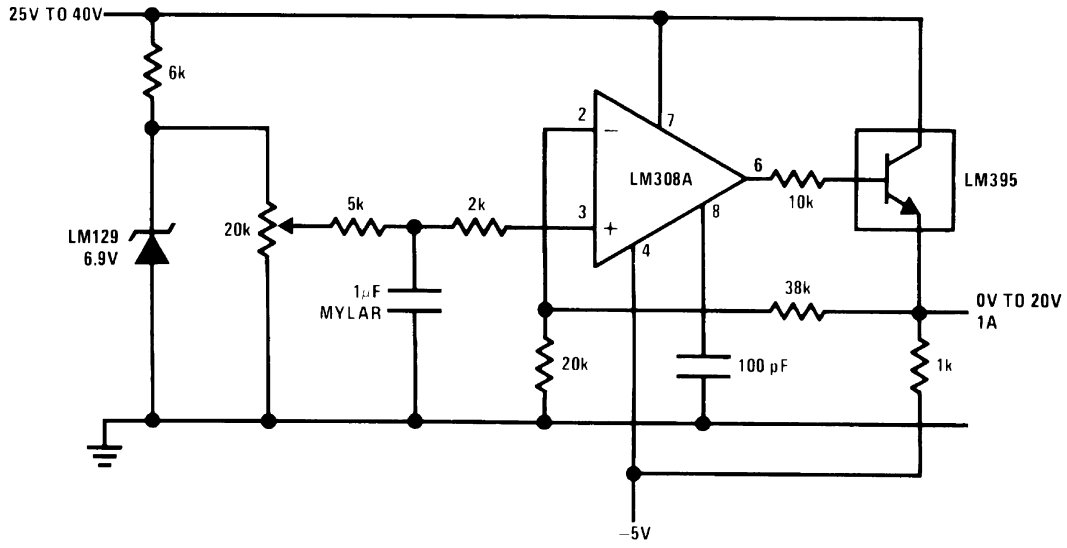

DS005714-9

External Reference for Temperature Transducer

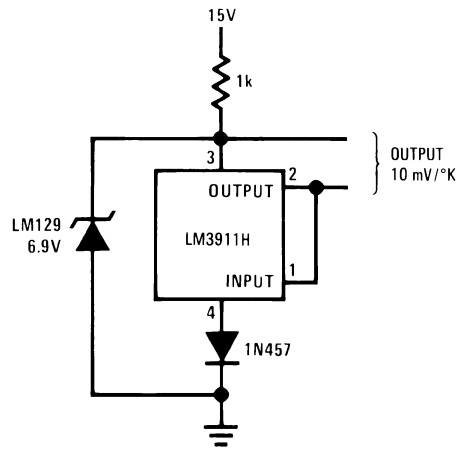

DS005714-2

Typical Applications (Continued)

Positive Current Source

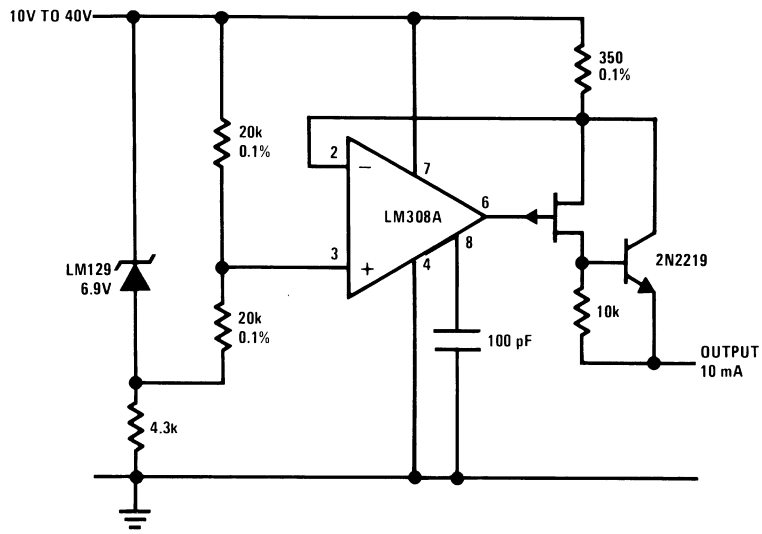

DS005714-11

Buffered Reference with Single Supply

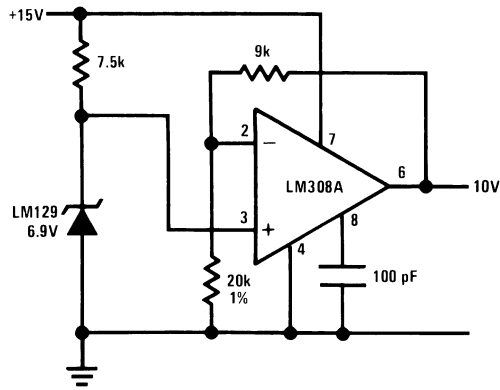

DS005714-3

Schematic Diagram

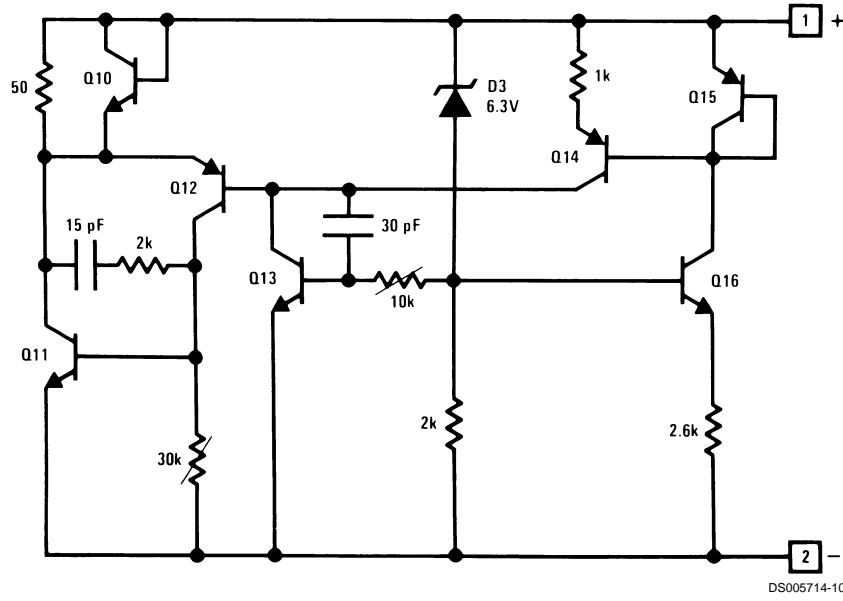

Typical Performance Characteristics

Reverse Characteristics

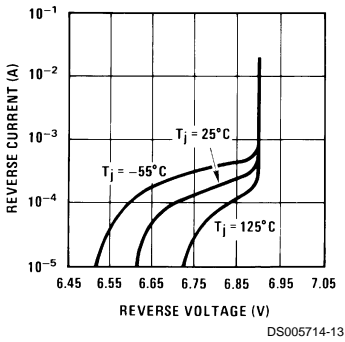

Response Time

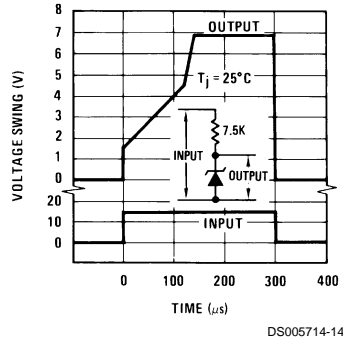

Forward Characteristics

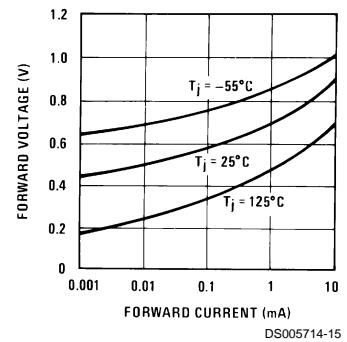

Dynamic Impedance

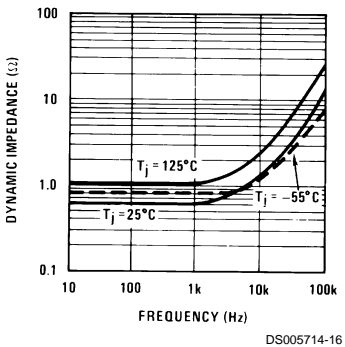

Reverse Voltage Change

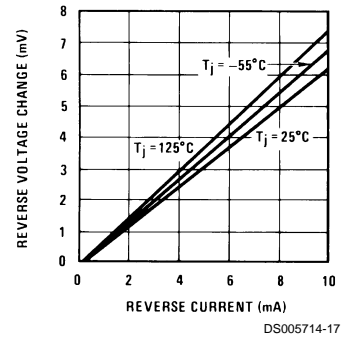

Zener Noise Voltage

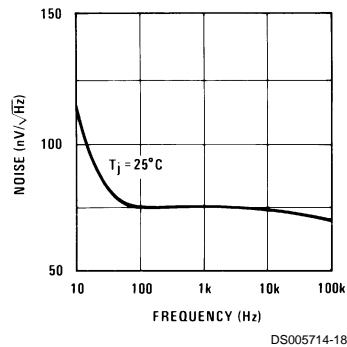

Typical Performance Characteristics (Continued)

Low Frequency Noise Voltage

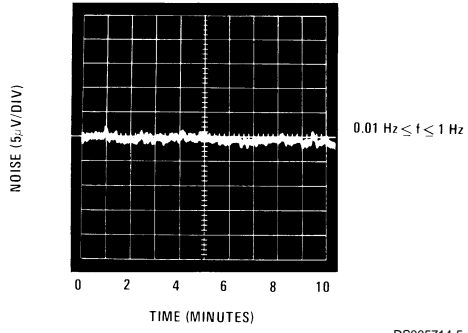

DS005714-5

Physical Dimensions inches (millimeters) unless otherwise noted

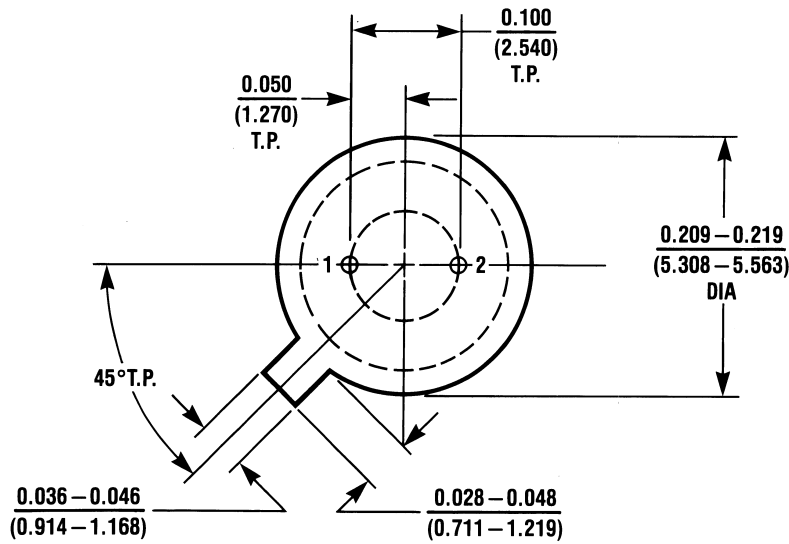
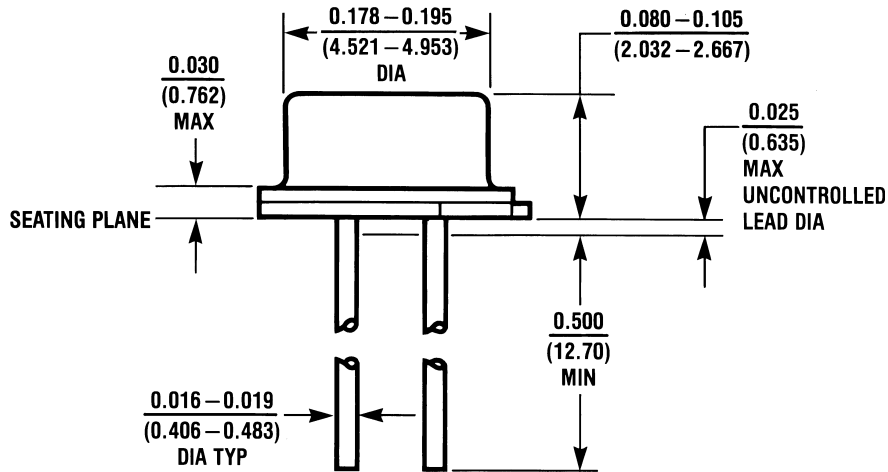

H02A (REV C)

Metal Can Package
 Order Number LM129AH, LM129AH/883, LM129BH, LM129BH/883,
 LM129CH, LM329AH, LM329BH, LM329CH, or LM329DH
NS Package H02A

Physical Dimensions inches (millimeters) unless otherwise noted (Continued)

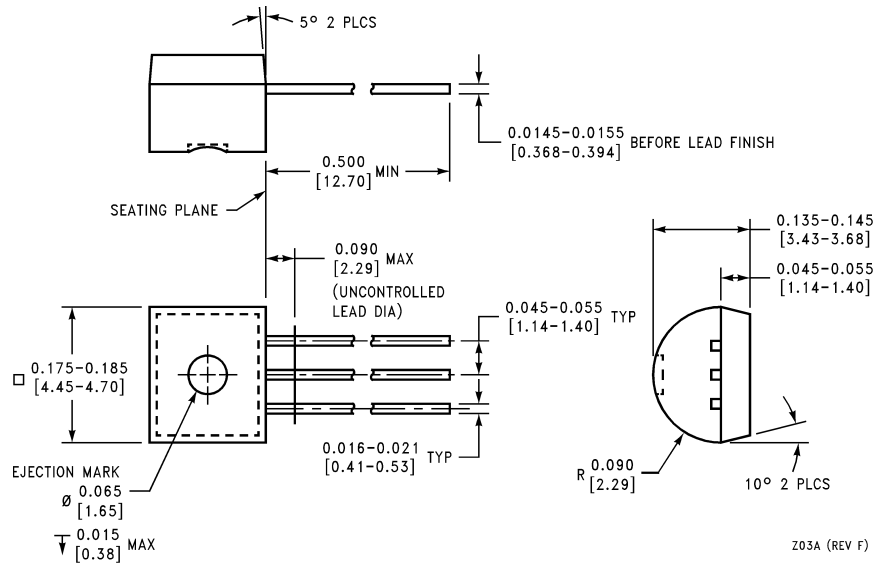

Plastic Package
Order Number LM329BZ, LM329CZ, or LM329DZ
NS Package Z03A

Z03A (REV F)

LIFE SUPPORT POLICY

NATIONAL'S PRODUCTS ARE NOT AUTHORIZED FOR USE AS CRITICAL COMPONENTS IN LIFE SUPPORT DEVICES OR SYSTEMS WITHOUT THE EXPRESS WRITTEN APPROVAL OF THE PRESIDENT AND GENERAL COUNSEL OF NATIONAL SEMICONDUCTOR CORPORATION. As used herein:

1. Life support devices or systems are devices or systems which, (a) are intended for surgical implant into the body, or (b) support or sustain life, and whose failure to perform when properly used in accordance with instructions for use provided in the labeling, can be reasonably expected to result in a significant injury to the user.
2. A critical component is any component of a life support device or system whose failure to perform can be reasonably expected to cause the failure of the life support device or system, or to affect its safety or effectiveness.

 **National Semiconductor Corporation**
Americas
Tel: 1-800-272-9959
Fax: 1-800-737-7018
Email: support@nsc.com
www.national.com

National Semiconductor Europe
Fax: +49 (0) 180-530 85 86
Email: europe.support@nsc.com
Deutsch Tel: +49 (0) 69 9508 6208
English Tel: +44 (0) 870 24 0 2171
Français Tel: +33 (0) 1 41 91 8790

National Semiconductor Asia Pacific Customer Response Group
Tel: 65-2544466
Fax: 65-2504466
Email: ap.support@nsc.com

National Semiconductor Japan Ltd.
Tel: 81-3-5639-7560
Fax: 81-3-5639-7507