

LM2907/LM2917 Frequency to Voltage Converter

General Description

The LM2907, LM2917 series are monolithic frequency to voltage converters with a high gain op amp/comparator designed to operate a relay, lamp, or other load when the input frequency reaches or exceeds a selected rate. The tachometer uses a charge pump technique and offers frequency doubling for low ripple, full input protection in two versions (LM2907-8, LM2917-8) and its output swings to ground for a zero frequency input.

Advantages

- Output swings to ground for zero frequency input
- Easy to use; $V_{OUT} = f_{IN} \times V_{CC} \times R1 \times C1$
- Only one RC network provides frequency doubling
- Zener regulator on chip allows accurate and stable frequency to voltage or current conversion (LM2917)

Features

- Ground referenced tachometer input interfaces directly with variable reluctance magnetic pickups
- Op amp/comparator has floating transistor output
- 50 mA sink or source to operate relays, solenoids, meters, or LEDs

- Frequency doubling for low ripple
- Tachometer has built-in hysteresis with either differential input or ground referenced input
- Built-in zener on LM2917
- $\pm 0.3\%$ linearity typical
- Ground referenced tachometer is fully protected from damage due to swings above V_{CC} and below ground

Applications

- Over/under speed sensing
- Frequency to voltage conversion (tachometer)
- Speedometers
- Breaker point dwell meters
- Hand-held tachometer
- Speed governors
- Cruise control
- Automotive door lock control
- Clutch control
- Horn control
- Touch or sound switches

Block and Connection Diagrams Dual-In-Line and Small Outline Packages, Top Views

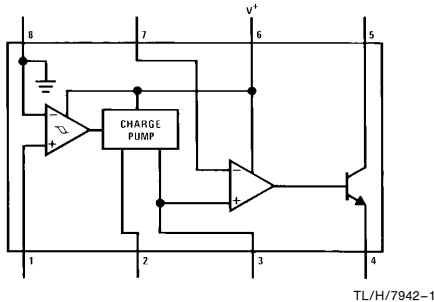

Order Number LM2907M-8 or LM2907N-8
See NS Package Number M08A or N08E

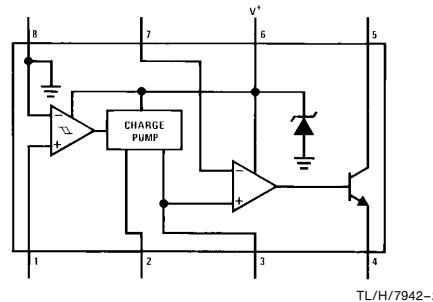

Order Number LM2917M-8 or LM2917N-8
See NS Package Number M08A or N08E

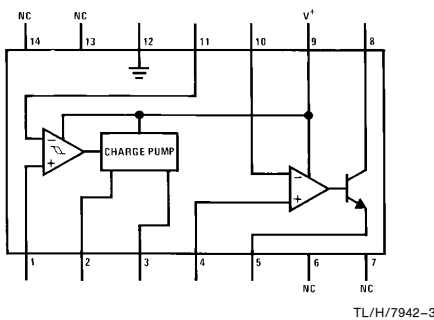

Order Number LM2907N
See NS Package Number N14A

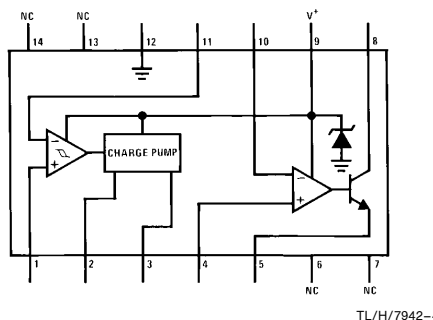

Order Number LM2917M or LM2917N
See NS Package Number M14A or N14A

Absolute Maximum Ratings (Note 1)

If Military/Aerospace specified devices are required, please contact the National Semiconductor Sales Office/Distributors for availability and specifications.

Supply Voltage	28V
Supply Current (Zener Options)	25 mA
Collector Voltage	28V
Differential Input Voltage	
Tachometer	28V
Op Amp/Comparator	28V
Input Voltage Range	
Tachometer LM2907-8, LM2917-8	± 28V
LM2907, LM2917	0.0V to +28V
Op Amp/Comparator	0.0V to +28V

Power Dissipation	
LM2907-8, LM2917-8	1200 mW
LM2907-14, LM2917-14	1580 mW
(See Note 1)	

Operating Temperature Range	−40°C to +85°C
Storage Temperature Range	−65°C to +150°C

Soldering Information	
Dual-In-Line Package	
Soldering (10 seconds)	260°C
Small Outline Package	
Vapor Phase (60 seconds)	215°C
Infrared (15 seconds)	220°C

See AN-450 "Surface Mounting Methods and Their Effect on Product Reliability" for other methods of soldering surface mount devices.

Electrical Characteristics $V_{CC} = 12 V_{DC}$, $T_A = 25^\circ C$, see test circuit

Symbol	Parameter	Conditions	Min	Typ	Max	Units
TACHOMETER						
	Input Thresholds	$V_{IN} = 250 \text{ mVp-p @ } 1 \text{ kHz (Note 2)}$	± 10	± 25	± 40	mV
	Hysteresis	$V_{IN} = 250 \text{ mVp-p @ } 1 \text{ kHz (Note 2)}$		30		mV
	Offset Voltage	$V_{IN} = 250 \text{ mVp-p @ } 1 \text{ kHz (Note 2)}$		3.5	10	mV
	LM2907/LM2917			5	15	mV
	LM2907-8/LM2917-8					
	Input Bias Current	$V_{IN} = \pm 50 \text{ mV}_{DC}$		0.1	1	μA
V_{OH}	Pin 2	$V_{IN} = +125 \text{ mV}_{DC} \text{ (Note 3)}$		8.3		V
V_{OL}	Pin 2	$V_{IN} = -125 \text{ mV}_{DC} \text{ (Note 3)}$		2.3		V
I_2, I_3	Output Current	$V_2 = V_3 = 6.0V \text{ (Note 4)}$	140	180	240	μA
I_3	Leakage Current	$I_2 = 0, V_3 = 0$			0.1	μA
K	Gain Constant	(Note 3)	0.9	1.0	1.1	
	Linearity	$f_{IN} = 1 \text{ kHz, } 5 \text{ kHz, } 10 \text{ kHz (Note 5)}$	−1.0	0.3	+1.0	%
OP/AMP COMPARATOR						
V_{OS}		$V_{IN} = 6.0V$		3	10	mV
I_{BIAS}		$V_{IN} = 6.0V$		50	500	nA
	Input Common-Mode Voltage		0		$V_{CC} - 1.5V$	V
	Voltage Gain			200		V/mV
	Output Sink Current	$V_C = 1.0$	40	50		mA
	Output Source Current	$V_E = V_{CC} - 2.0$		10		mA
	Saturation Voltage	$I_{SINK} = 5 \text{ mA}$		0.1	0.5	V
		$I_{SINK} = 20 \text{ mA}$			1.0	V
		$I_{SINK} = 50 \text{ mA}$		1.0	1.5	V

Electrical Characteristics $V_{CC} = 12 V_{DC}$, $T_A = 25^\circ C$, see test circuit (Continued)

Symbol	Parameter	Conditions	Min	Typ	Max	Units
ZENER REGULATOR						
	Regulator Voltage	$R_{DROP} = 470\Omega$		7.56		V
	Series Resistance			10.5	15	Ω
	Temperature Stability			+ 1		mV/ $^\circ C$
	TOTAL SUPPLY CURRENT			3.8	6	mA

Note 1: For operation in ambient temperatures above $25^\circ C$, the device must be derated based on a $150^\circ C$ maximum junction temperature and a thermal resistance of $101^\circ C/W$ junction to ambient for LM2907-8 and LM2917-8, and $79^\circ C/W$ junction to ambient for LM2907-14 and LM2917-14.

Note 2: Hysteresis is the sum $+V_{TH} - (-V_{TH})$, offset voltage is their difference. See test circuit.

Note 3: V_{OH} is equal to $\frac{3}{4} \times V_{CC} - 1 V_{BE}$. V_{OL} is equal to $\frac{1}{4} \times V_{CC} - 1 V_{BE}$ therefore $V_{OH} - V_{OL} = V_{CC}/2$. The difference, $V_{OH} - V_{OL}$, and the mirror gain, I_2/I_3 , are the two factors that cause the tachometer gain constant to vary from 1.0.

Note 4: Be sure when choosing the time constant $R1 \times C1$ that $R1$ is such that the maximum anticipated output voltage at pin 3 can be reached with $I_3 \times R1$. The maximum value for $R1$ is limited by the output resistance of pin 3 which is greater than $10 M\Omega$ typically.

Note 5: Nonlinearity is defined as the deviation of V_{OUT} (@ pin 3) for $f_{IN} = 5$ kHz from a straight line defined by the V_{OUT} @ 1 kHz and V_{OUT} @ 10 kHz. $C1 = 1000$ pF, $R1 = 68k$ and $C2 = 0.22$ mF.

General Description (Continued)

The op amp/comparator is fully compatible with the tachometer and has a floating transistor as its output. This feature allows either a ground or supply referred load of up to 50 mA. The collector may be taken above V_{CC} up to a maximum V_{CE} of 28V.

The two basic configurations offered include an 8-pin device with a *ground referenced tachometer* input and an internal connection between the tachometer output and the op amp non-inverting input. This version is well suited for single speed or frequency switching or fully buffered frequency to voltage conversion applications.

The more versatile configurations provide differential tachometer input and uncommitted op amp inputs. With this version the tachometer input may be floated and the op amp becomes suitable for active filter conditioning of the tachometer output.

Both of these configurations are available with an active shunt regulator connected across the power leads. The regulator clamps the supply such that stable frequency to voltage and frequency to current operations are possible with any supply voltage and a suitable resistor.

Test Circuit and Waveform

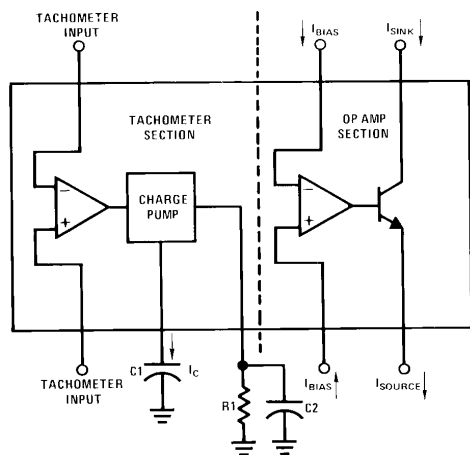

TL/H/7942-6

Tachometer Input Threshold Measurement

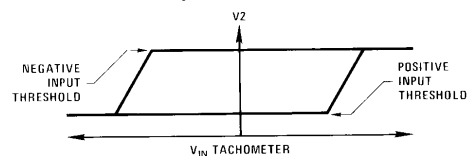

TL/H/7942-7

Typical Performance Characteristics

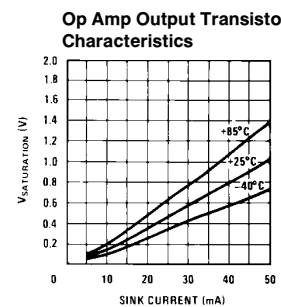
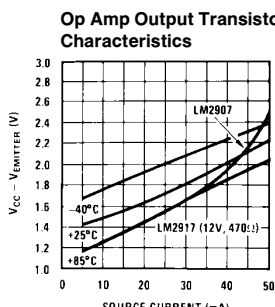
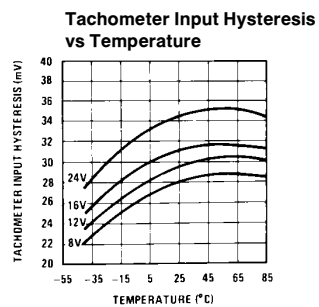
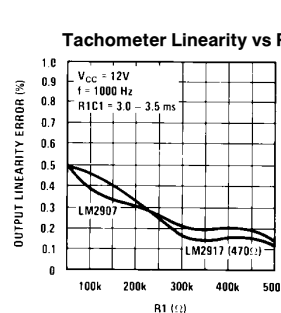
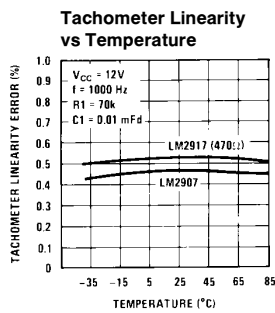
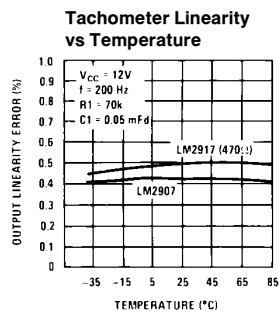
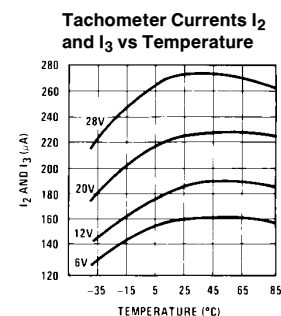
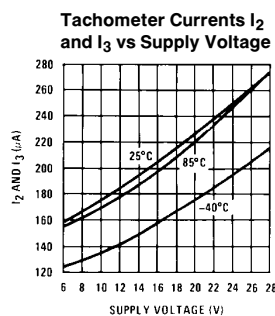
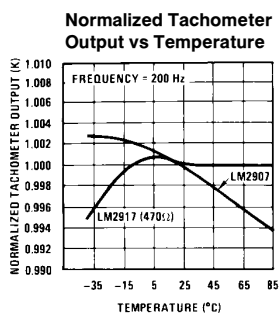
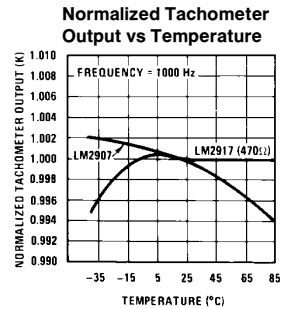
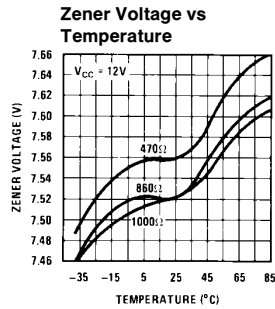
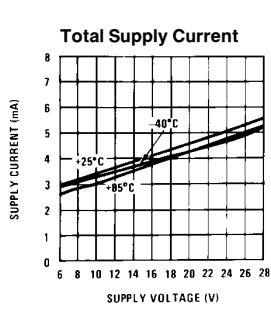

TL/H/7942-5

Applications Information

The LM2907 series of tachometer circuits is designed for minimum external part count applications and maximum versatility. In order to fully exploit its features and advantages let's examine its theory of operation. The first stage of operation is a differential amplifier driving a positive feedback flip-flop circuit. The input threshold voltage is the amount of differential input voltage at which the output of this stage changes state. Two options (LM2907-8, LM2917-8) have one input internally grounded so that an input signal must swing above and below ground and exceed the input thresholds to produce an output. This is offered specifically for magnetic variable reluctance pickups which typically provide a single-ended ac output. This single input is also fully protected against voltage swings to $\pm 28V$, which are easily attained with these types of pickups.

The differential input options (LM2907, LM2917) give the user the option of setting his own input switching level and still have the hysteresis around that level for excellent noise rejection in any application. Of course in order to allow the inputs to attain common-mode voltages above ground, input protection is removed and neither input should be taken outside the limits of the supply voltage being used. It is very important that an input not go below ground without some resistance in its lead to limit the current that will then flow in the epi-substrate diode.

Following the input stage is the charge pump where the input frequency is converted to a dc voltage. To do this requires one timing capacitor, one output resistor, and an integrating or filter capacitor. When the input stage changes state (due to a suitable zero crossing or differential voltage on the input) the timing capacitor is either charged or discharged linearly between two voltages whose difference is $V_{CC}/2$. Then in one half cycle of the input frequency or a time equal to $1/2 f_{IN}$ the change in charge on the timing capacitor is equal to $V_{CC}/2 \times C1$. The average amount of current pumped into or out of the capacitor then is:

$$\frac{\Delta Q}{T} = i_{C(AVG)} = C1 \times \frac{V_{CC}}{2} \times (2f_{IN}) = V_{CC} \times f_{IN} \times C1$$

The output circuit mirrors this current very accurately into the load resistor R1, connected to ground, such that if the pulses of current are integrated with a filter capacitor, then $V_O = i_C \times R1$, and the total conversion equation becomes:

$$V_O = V_{CC} \times f_{IN} \times C1 \times R1 \times K$$

Where K is the gain constant—typically 1.0.

Typical Applications

Minimum Component Tachometer

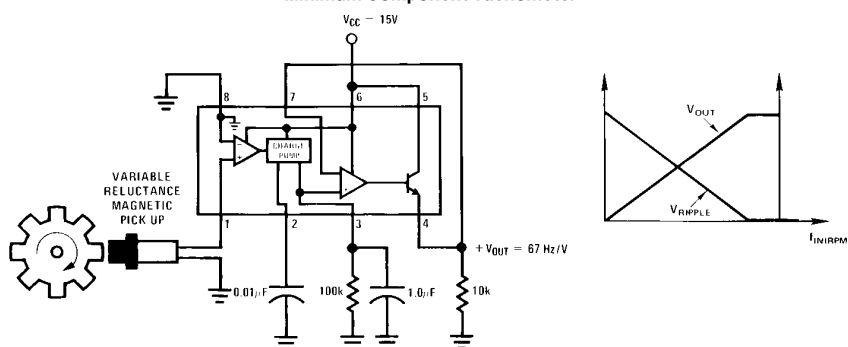

The size of C2 is dependent only on the amount of ripple voltage allowable and the required response time.

CHOOSING R1 AND C1

There are some limitations on the choice of R1 and C1 which should be considered for optimum performance. The timing capacitor also provides internal compensation for the charge pump and should be kept larger than 500 pF for very accurate operation. Smaller values can cause an error current on R1, especially at low temperatures. Several considerations must be met when choosing R1. The output current at pin 3 is internally fixed and therefore $V_O/R1$ must be less than or equal to this value. If R1 is too large, it can become a significant fraction of the output impedance at pin 3 which degrades linearity. Also output ripple voltage must be considered and the size of C2 is affected by R1. An expression that describes the ripple content on pin 3 for a single R1C2 combination is:

$$V_{RIPPLE} = \frac{V_{CC}}{2} \times \frac{C1}{C2} \times \left(1 - \frac{V_{CC} \times f_{IN} \times C1}{I_2} \right) \text{ pk-pk}$$

It appears R1 can be chosen independent of ripple, however response time, or the time it takes V_{OUT} to stabilize at a new voltage increases as the size of C2 increases, so a compromise between ripple, response time, and linearity must be chosen carefully.

As a final consideration, the maximum attainable input frequency is determined by V_{CC} , C1 and I_2 :

$$f_{MAX} = \frac{I_2}{C1 \times V_{CC}}$$

USING ZENER REGULATED OPTIONS (LM2917)

For those applications where an output voltage or current must be obtained independent of supply voltage variations, the LM2917 is offered. The most important consideration in choosing a dropping resistor from the unregulated supply to the device is that the tachometer and op amp circuitry alone require about 3 mA at the voltage level provided by the zener. At low supply voltages there must be some current flowing in the resistor above the 3 mA circuit current to operate the regulator. As an example, if the raw supply varies from 9V to 16V, a resistance of 470 Ω will minimize the zener voltage variation to 160 mV. If the resistance goes under 400 Ω or over 600 Ω the zener variation quickly rises above 200 mV for the same input variation.

TL/H/7942-8

Typical Applications (Continued)

“Speed Switch” Load is Energized When $f_{IN} \geq \frac{1}{2RC}$

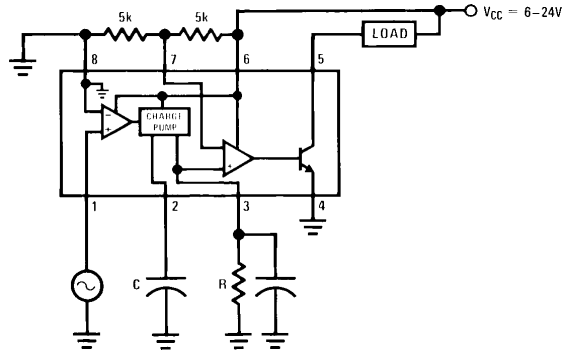

TL/H/7942-9

Zener Regulated Frequency to Voltage Converter

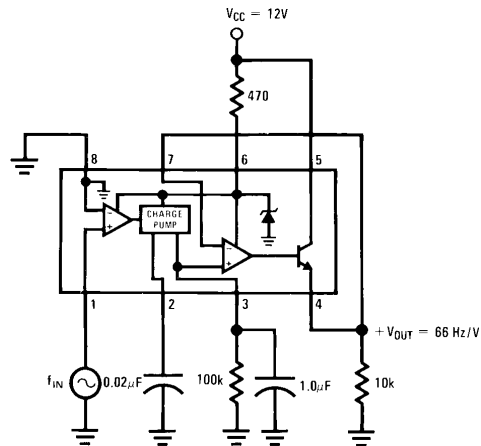

TL/H/7942-10

Breaker Point Dwell Meter

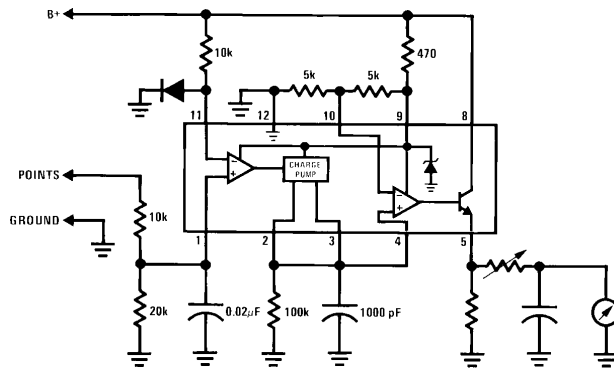

TL/H/7942-11

Typical Applications (Continued)

Voltage Driven Meter Indicating Engine RPM
 $V_O = 6V @ 400 \text{ Hz or } 6000 \text{ ERPM (8 Cylinder Engine)}$

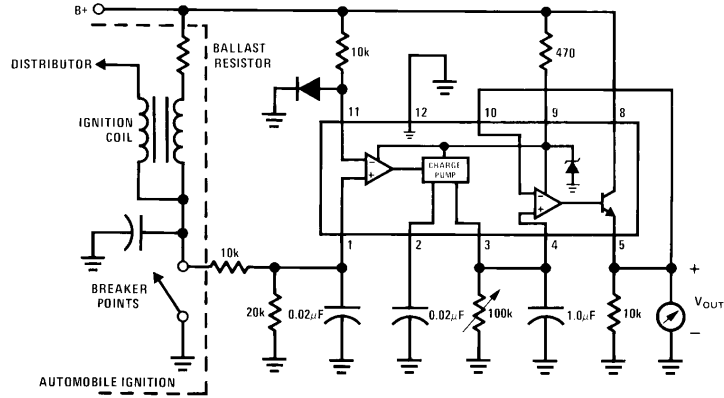

TL/H/7942-12

Current Driven Meter Indicating Engine RPM
 $I_O = 10 \text{ mA @ } 300 \text{ Hz or } 6000 \text{ ERPM (6 Cylinder Engine)}$

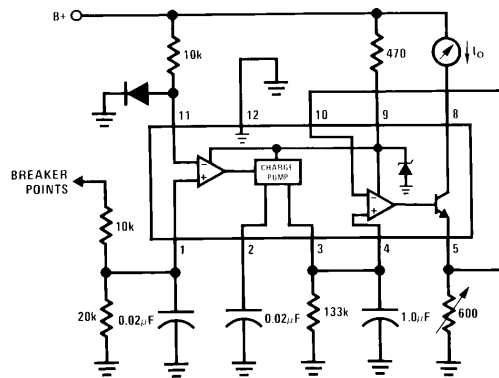

TL/H/7942-13

Capacitance Meter
 $V_{OUT} = 1V-10V \text{ for } C_X = 0.01 \text{ to } 0.1 \text{ mFd}$
 $(R = 111k)$

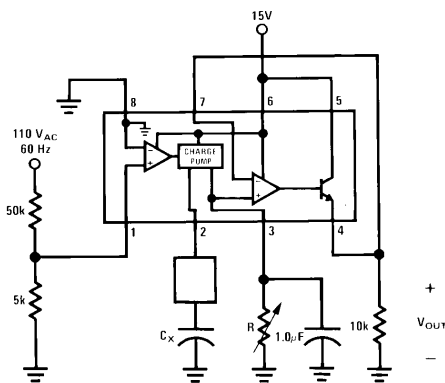

TL/H/7942-14

Typical Applications (Continued)

Two-Wire Remote Speed Switch

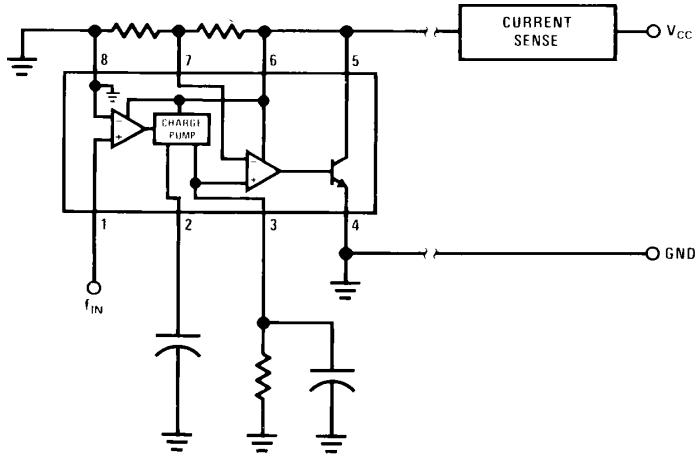

TL/H/7942-15

100 Cycle Delay Switch

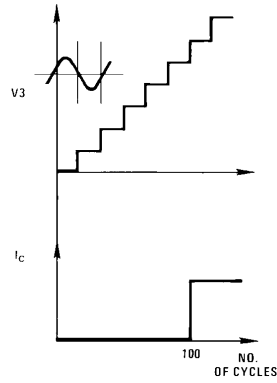
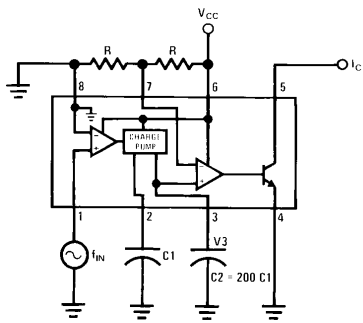

V3 steps up in voltage by the amount $\frac{V_{CC} \times C1}{C2}$
for each complete input cycle (2 zero crossings)

Example:

If $C2 = 200 C1$ after 100 consecutive input cycles.

$V3 = 1/2 V_{CC}$

TL/H/7942-16

Typical Applications (Continued)

Variable Reluctance Magnetic Pickup Buffer Circuits

Precision two-shot output frequency equals twice input frequency.

$$\text{Pulse width} = \frac{V_{CC} C_1}{2 I_2}$$

$$\text{Pulse height} = V_{ZENER}$$

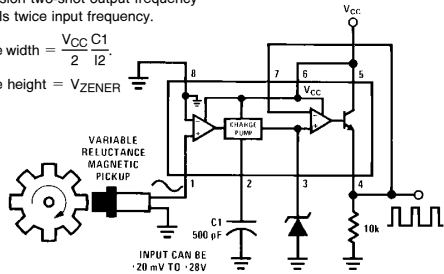

TL/H/7942-39

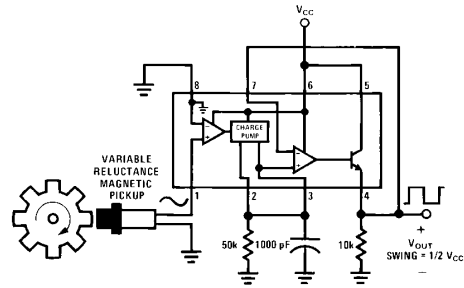

TL/H/7942-17

Finger Touch or Contact Switch

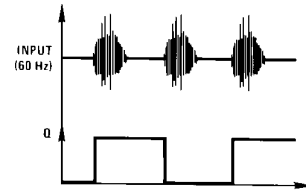
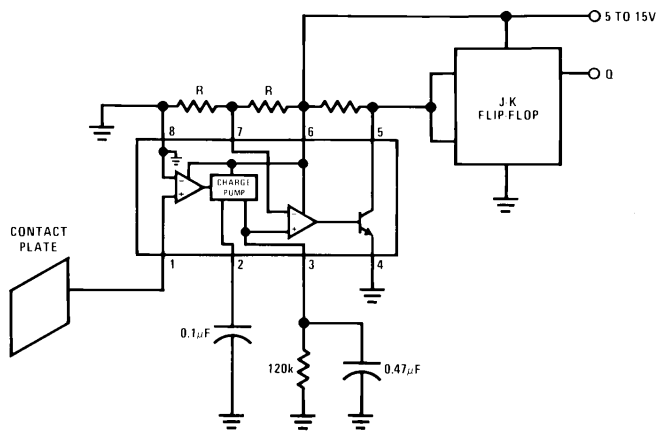

TL/H/7942-19

TL/H/7942-18

Flashing LED Indicates Overspeed

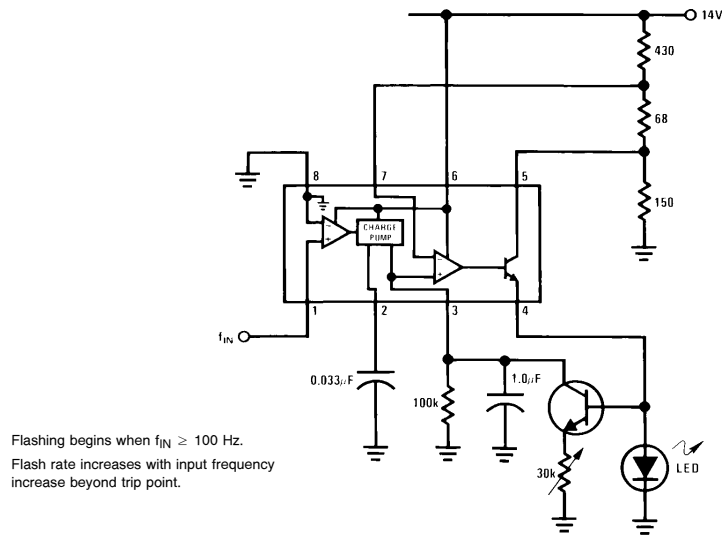

Flashing begins when $f_{IN} \geq 100$ Hz.
Flash rate increases with input frequency increase beyond trip point.

TL/H/7942-20

Typical Applications (Continued)

Frequency to Voltage Converter with 2 Pole Butterworth Filter to Reduce Ripple

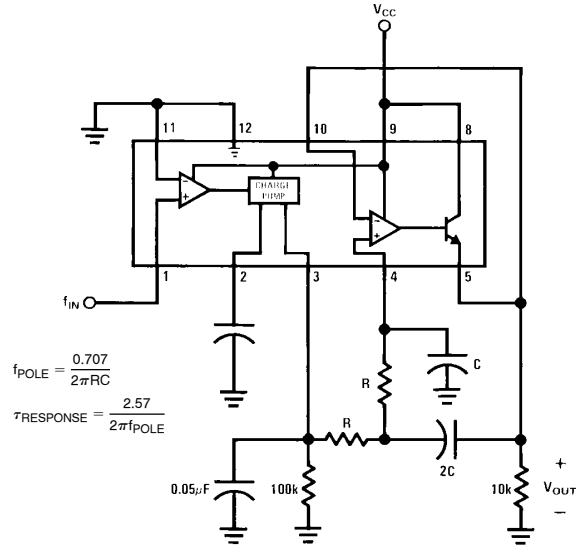

TL/H/7942-21

Overspeed Latch

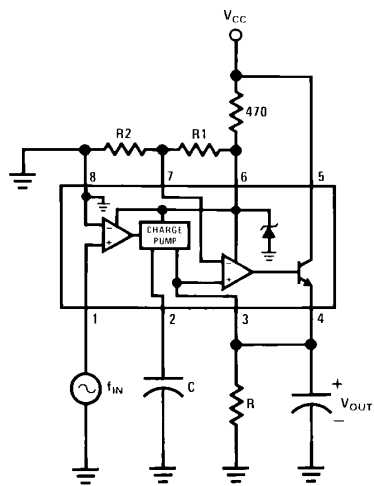

TL/H/7942-22

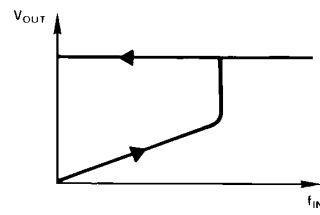

Output latches when

$$f_{IN} = \frac{R2}{R1 + R2} \frac{1}{RC}$$
 Reset by removing V_{CC} .

TL/H/7942-23

Typical Applications (Continued)

Some Frequency Switch Applications May Require Hysteresis in the Comparator Function Which can be Implemented in Several Ways:

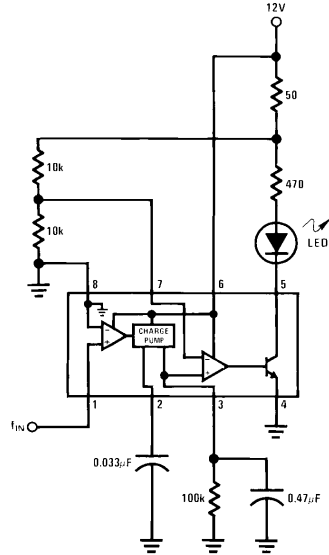

TL/H/7942-24

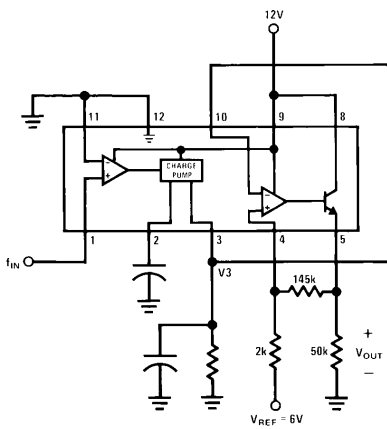

TL/H/7942-25

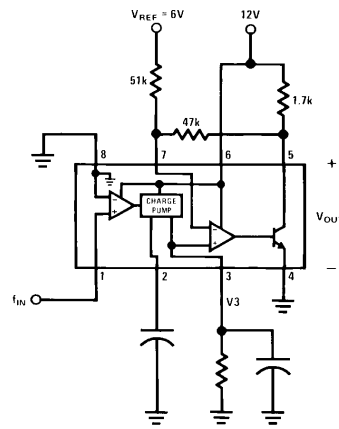

TL/H/7942-26

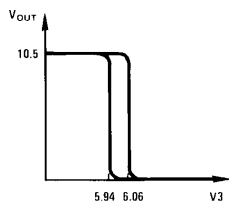

TL/H/7942-27

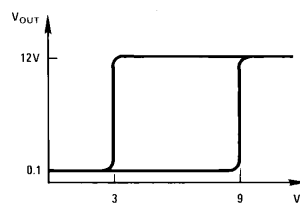

TL/H/7942-28

Typical Applications (Continued)

Changing the Output Voltage for an Input Frequency of Zero

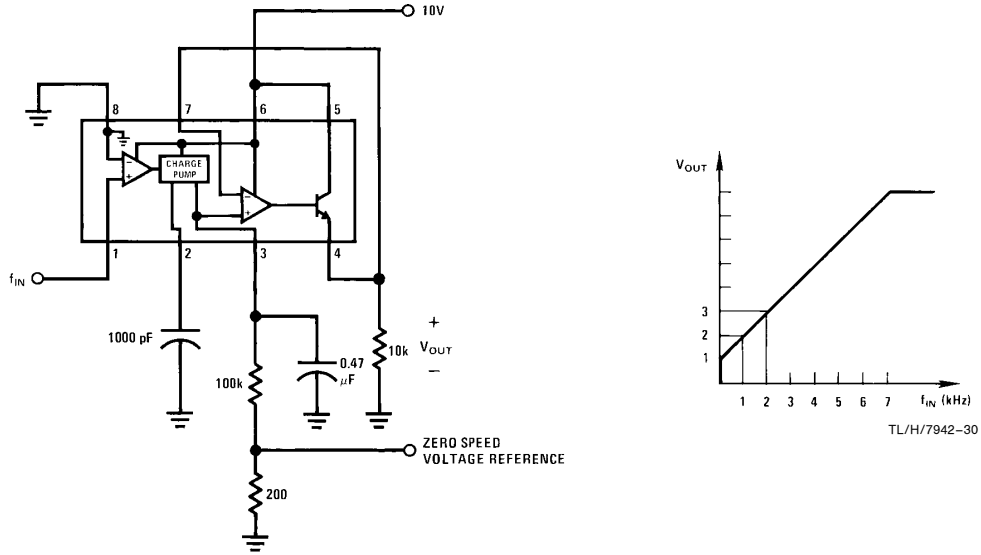

TL/H/7942-29

Changing Tachometer Gain Curve or Clamping the Minimum Output Voltage

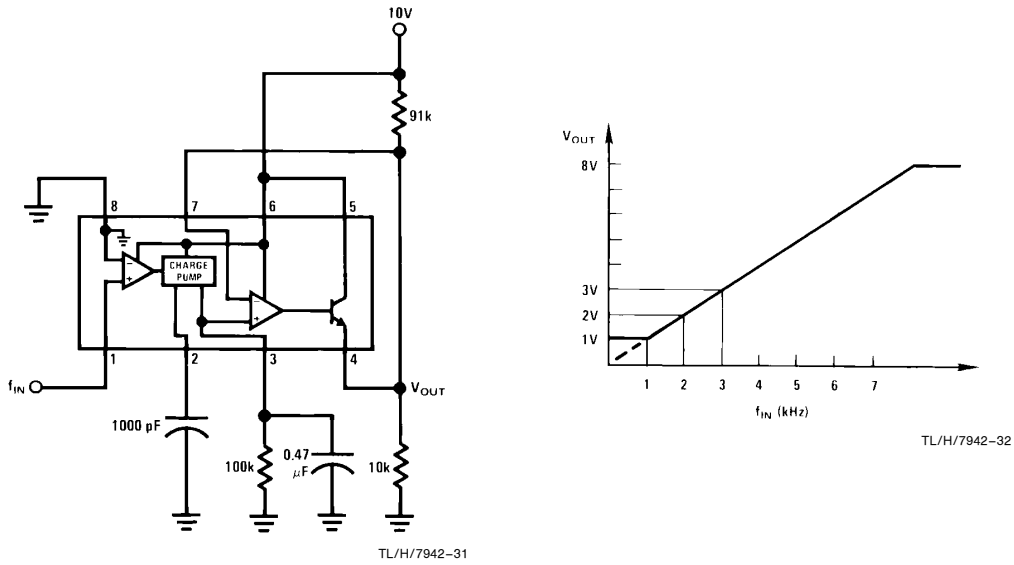

TL/H/7942-32

Anti-Skid Circuit Functions

“Select-Low” Circuit

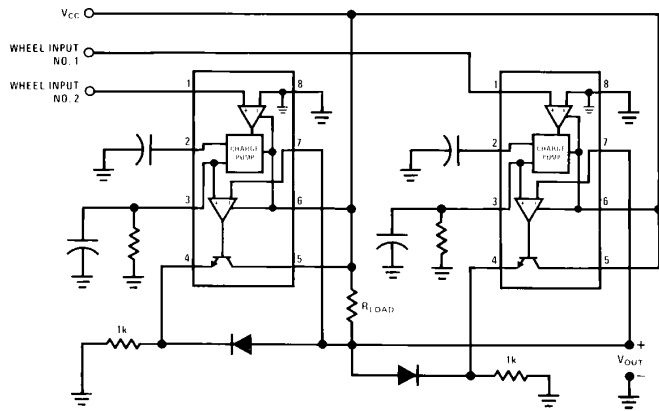

TL/H/7942-33

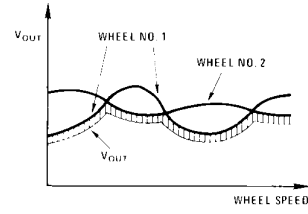

V_{OUT} is proportional to the lower of the two input wheel speeds.

TL/H/7942-34

“Select-High” Circuit

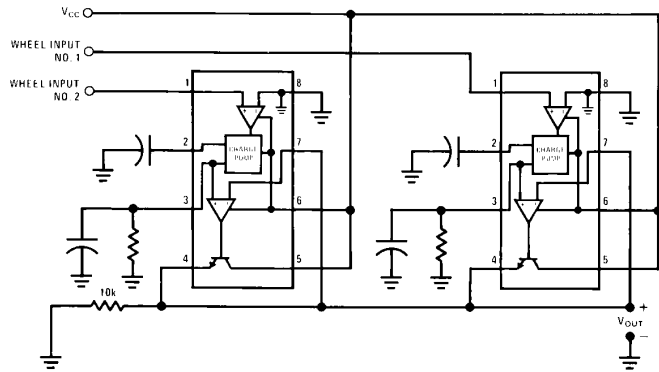

TL/H/7942-35

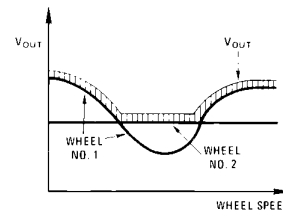

V_{OUT} is proportional to the higher of the two input wheel speeds.

TL/H/7942-36

“Select-Average” Circuit

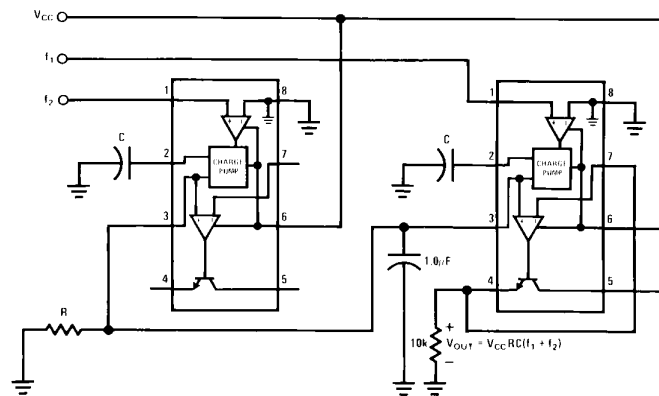

TL/H/7942-37

Equivalent Schematic Diagram

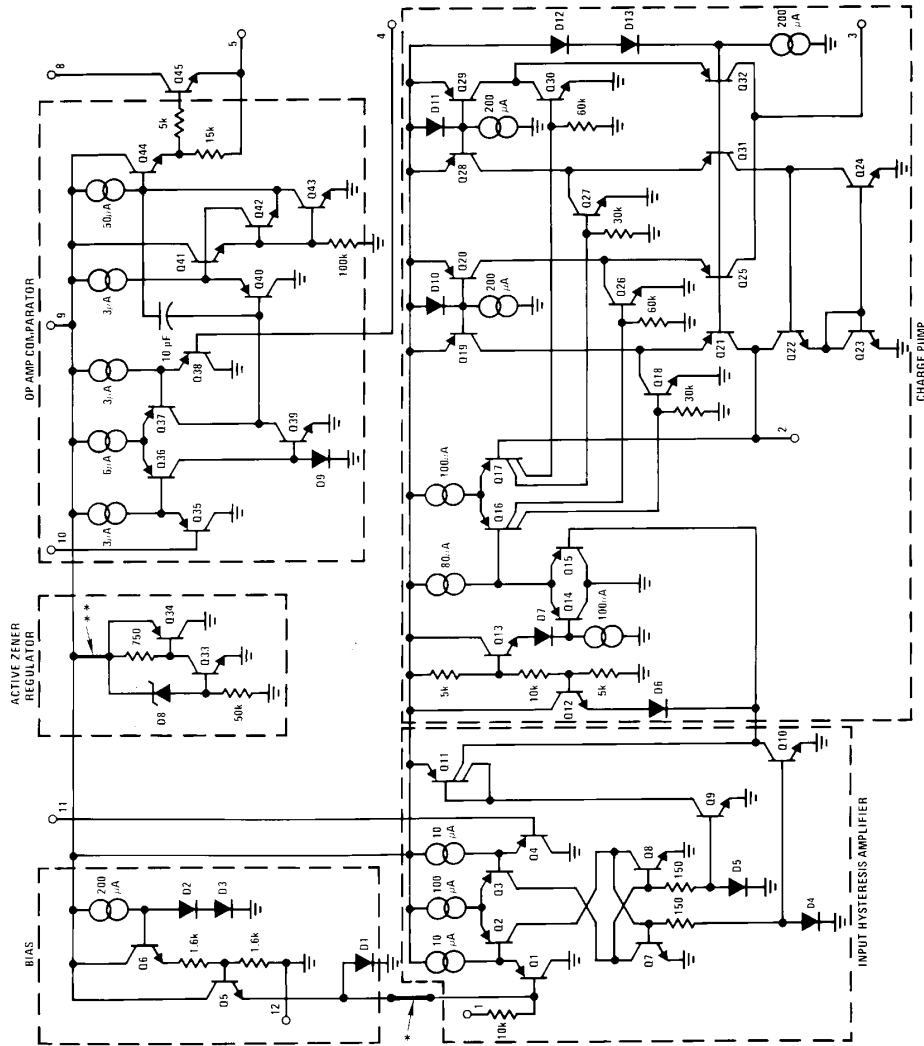

TL/H/7942-38

*This connection made on LM2907-8 and LM2917-8 only.
 **This connection made on LM2917 and LM2917-8 only.

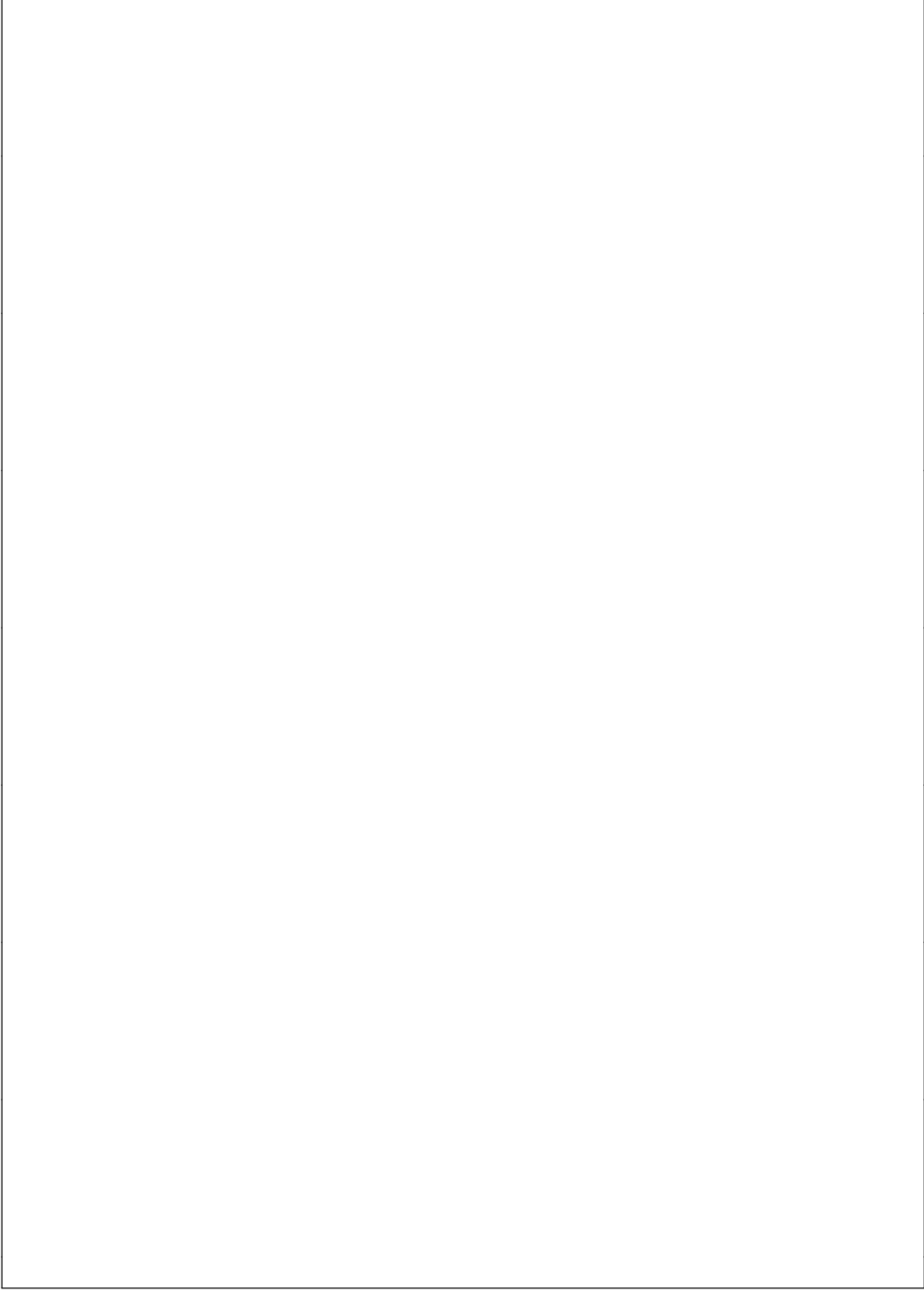

Physical Dimensions inches (millimeters)

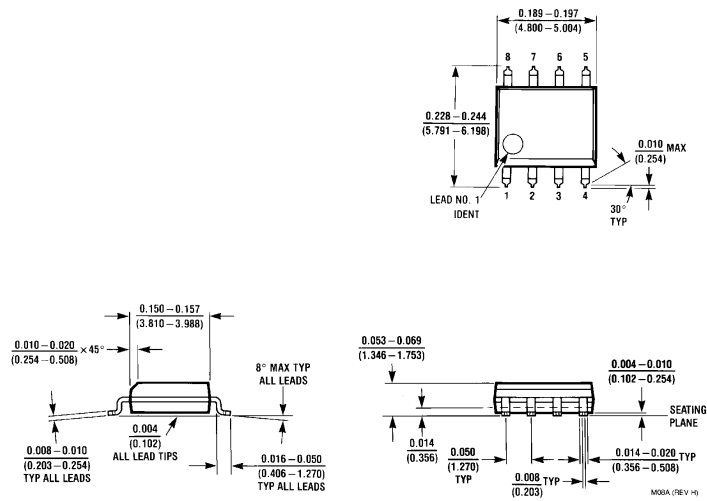

8-Lead (0.150" Wide) Molded Small Outline Package, JEDEC
Order Number LM2907M-8 or LM2917M-8
NS Package Number M08A

Physical Dimensions inches (millimeters) (Continued)

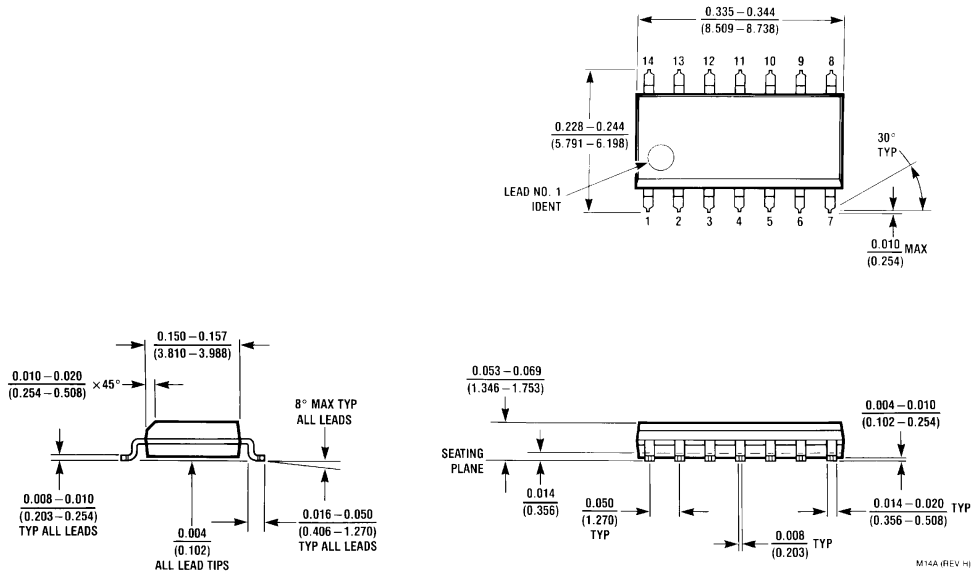

Molded SO Package (M)
Order Number LM2917M
NS Package Number M14A

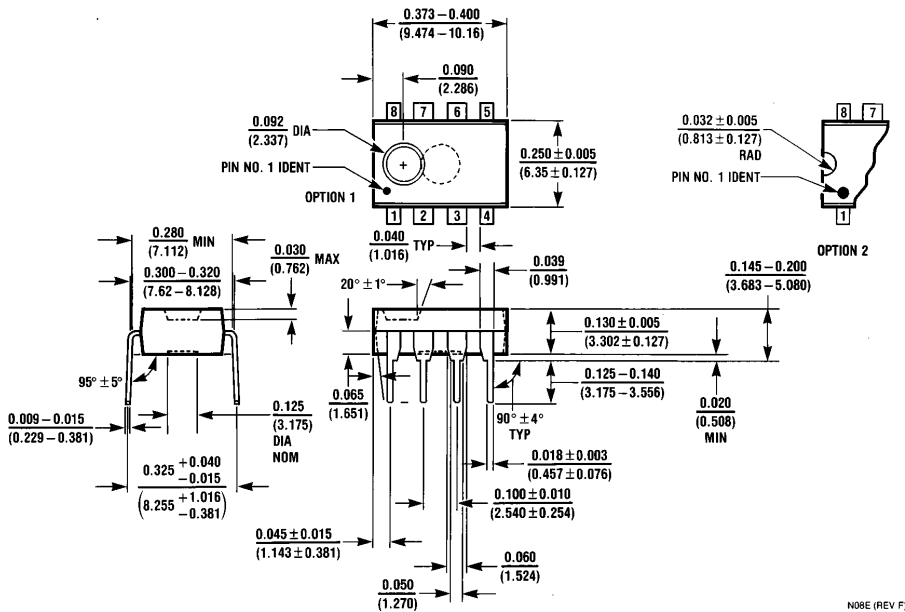

Molded Dual-In-Line Package (N)
Order Number LM2907N-8 or LM2917N-8
NS Package Number N08E

Physical Dimensions inches (millimeters) (Continued)

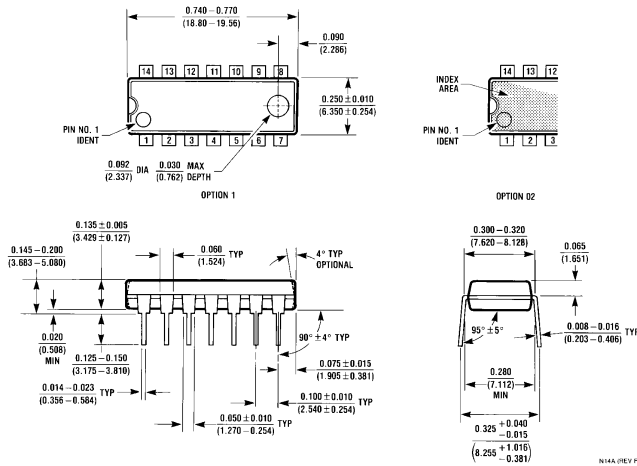

Molded Dual-In-Line Package (N)
Order Number LM2907N or LM2917N
NS Package Number N14A

LIFE SUPPORT POLICY

NATIONAL'S PRODUCTS ARE NOT AUTHORIZED FOR USE AS CRITICAL COMPONENTS IN LIFE SUPPORT DEVICES OR SYSTEMS WITHOUT THE EXPRESS WRITTEN APPROVAL OF THE PRESIDENT OF NATIONAL SEMICONDUCTOR CORPORATION. As used herein:

1. Life support devices or systems are devices or systems which, (a) are intended for surgical implant into the body, or (b) support or sustain life, and whose failure to perform, when properly used in accordance with instructions for use provided in the labeling, can be reasonably expected to result in a significant injury to the user.
2. A critical component is any component of a life support device or system whose failure to perform can be reasonably expected to cause the failure of the life support device or system, or to affect its safety or effectiveness.



National Semiconductor Corporation
 1111 West Bardin Road
 Arlington, TX 76017
 Tel: 1(800) 272-9959
 Fax: 1(800) 737-7018

National Semiconductor Europe
 Fax: (+49) 0-180-530 85 86
 Email: cnjwge@tevm2.nsc.com
 Deutsch Tel: (+49) 0-180-530 85 85
 English Tel: (+49) 0-180-532 78 32
 Français Tel: (+49) 0-180-532 93 58
 Italiano Tel: (+49) 0-180-534 16 80

National Semiconductor Hong Kong Ltd.
 13th Floor, Straight Block,
 Ocean Centre, 5 Canton Rd.
 Tsimshatsui, Kowloon
 Hong Kong
 Tel: (852) 2737-1600
 Fax: (852) 2736-9960

National Semiconductor Japan Ltd.
 Tel: 81-043-299-2309
 Fax: 81-043-299-2408

National does not assume any responsibility for use of any circuitry described, no circuit patent licenses are implied and National reserves the right at any time without notice to change said circuitry and specifications.