

LM146/LM346 Programmable Quad Operational Amplifiers

General Description

The LM146 series of quad op amps consists of four independent, high gain, internally compensated, low power, programmable amplifiers. Two external resistors (R_{SET}) allow the user to program the gain bandwidth product, slew rate, supply current, input bias current, input offset current and input noise. For example, the user can trade-off supply current for bandwidth or optimize noise figure for a given source resistance. In a similar way, other amplifier characteristics can be tailored to the application. Except for the two programming pins at the end of the package, the LM146 pin-out is the same as the LM124 and LM148.

Features

- ($I_{SET}=10 \mu A$)
- Programmable electrical characteristics
 - Battery-powered operation
 - Low supply current: 350 μA /amplifier
 - Guaranteed gain bandwidth product: 0.8 MHz min
 - Large DC voltage gain: 120 dB
 - Low noise voltage: 28 nV/\sqrt{Hz}
 - Wide power supply range: $\pm 1.5V$ to $\pm 22V$
 - Class AB output stage—no crossover distortion
 - Ideal pin out for Biquad active filters
 - Input bias currents are temperature compensated

Connection Diagram

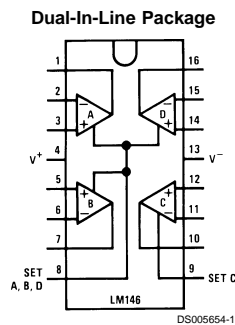

Top View
Order Number LM146J, LM146J/883,
LM346M or LM346N
See NS Package Number
J16A, M16A or N16A

PROGRAMMING EQUATIONS

Total Supply Current = 1.4 mA ($I_{SET}/10 \mu A$)

Gain Bandwidth Product = 1 MHz ($I_{SET}/10 \mu A$)

Slew Rate = 0.4V/ μs ($I_{SET}/10 \mu A$)

Input Bias Current ≈ 50 nA ($I_{SET}/10 \mu A$)

I_{SET} = Current into pin 8, pin 9 (see schematic-diagram)

$$I_{SET} = \frac{V^+ - V^- - 0.6V}{R_{SET}}$$

Schematic Diagram

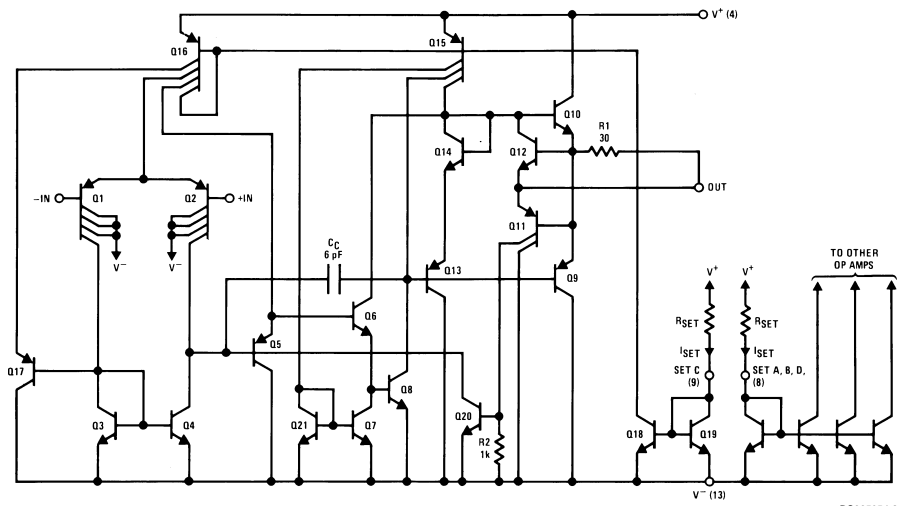

DS005654-2

Absolute Maximum Ratings (Notes 1, 5)

If Military/Aerospace specified devices are required, please contact the National Semiconductor Sales Office/Distributors for availability and specifications.

	LM146	LM346
Supply Voltage	±22V	±18V
Differential Input Voltage (Note 1)	±30V	±30V
CM Input Voltage (Note 1)	±15V	±15V
Power Dissipation (Note 2)	900 mW	500 mW
Output Short-Circuit Duration (Note 3)	Continuous	Continuous
Operating Temperature Range	-55°C to +125°C	0°C to +70°C
Maximum Junction Temperature	150°C	100°C
Storage Temperature Range	-65°C to +150°C	-65°C to +150°C
Lead Temperature (Soldering, 10 seconds)	260°C	260°C
Thermal Resistance (θ_{jA}), (Note 2)		
Cavity DIP (J) Pd	900 mW	900 mW
θ_{jA}	100°C/W	100°C/W
Small Outline (M) θ_{jA}		115°C/W
Molded DIP (N) Pd		500 mW
θ_{jA}		90°C/W
Soldering Information		
Dual-In-Line Package		
Soldering (10 seconds)	+260°C	+260°C
Small Outline Package		
Vapor Phase (60 seconds)	+215°C	+215°C
Infrared (15 seconds)	+220°C	+220°C

See AN-450 "Surface Mounting Methods and Their Effect on Product Reliability" for other methods of soldering surface mount devices.

ESD rating is to be determined.

DC Electrical Characteristics

($V_S = \pm 15V$, $I_{SET} = 10 \mu A$), (Note 4)

Parameter	Conditions	LM146			LM346			Units
		Min	Typ	Max	Min	Typ	Max	
Input Offset Voltage	$V_{CM} = 0V$, $R_S \leq 50\Omega$, $T_A = 25^\circ C$		0.5	5		0.5	6	mV
Input Offset Current	$V_{CM} = 0V$, $T_A = 25^\circ C$		2	20		2	100	nA
Input Bias Current	$V_{CM} = 0V$, $T_A = 25^\circ C$		50	100		50	250	nA
Supply Current (4 Op Amps)	$T_A = 25^\circ C$		1.4	2.0		1.4	2.5	mA
Large Signal Voltage Gain	$R_L = 10 k\Omega$, $\Delta V_{OUT} = \pm 10V$, $T_A = 25^\circ C$	100	1000		50	1000		V/mV
Input CM Range	$T_A = 25^\circ C$	±13.5	±14		±13.5	±14		V
CM Rejection Ratio	$R_S \leq 10 k\Omega$, $T_A = 25^\circ C$	80	100		70	100		dB
Power Supply Rejection Ratio	$R_S \leq 10 k\Omega$, $T_A = 25^\circ C$, $V_S = \pm 5$ to $\pm 15V$	80	100		74	100		dB
Output Voltage Swing	$R_L \geq 10 k\Omega$, $T_A = 25^\circ C$	±12	±14		±12	±14		V
Short-Circuit	$T_A = 25^\circ C$	5	20	35	5	20	35	mA
Gain Bandwidth Product	$T_A = 25^\circ C$	0.8	1.2		0.5	1.2		MHz
Phase Margin	$T_A = 25^\circ C$		60			60		Deg
Slew Rate	$T_A = 25^\circ C$		0.4			0.4		V/ μs
Input Noise Voltage	$f = 1 kHz$, $T_A = 25^\circ C$		28			28		nV/ \sqrt{Hz}
Channel Separation	$R_L = 10 k\Omega$, $\Delta V_{OUT} = 0V$ to $\pm 12V$, $T_A = 25^\circ C$		120			120		dB
Input Resistance	$T_A = 25^\circ C$		1.0			1.0		M Ω
Input Capacitance	$T_A = 25^\circ C$		2.0			2.0		pF
Input Offset Voltage	$V_{CM} = 0V$, $R_S \leq 50\Omega$		0.5	6		0.5	7.5	mV

DC Electrical Characteristics (Continued)

($V_S = \pm 15V$, $I_{SET} = 10 \mu A$), (Note 4)

Parameter	Conditions	LM146			LM346			Units
		Min	Typ	Max	Min	Typ	Max	
Input Offset Current	$V_{CM} = 0V$		2	25		2	100	nA
Input Bias Current	$V_{CM} = 0V$		50	100		50	250	nA
Supply Current (4 Op Amps)			1.7	2.2		1.7	2.5	mA
Large Signal Voltage Gain	$R_L = 10 \text{ k}\Omega$, $\Delta V_{OUT} = \pm 10V$	50	1000		25	1000		V/mV
Input CM Range		± 13.5	± 14		± 13.5	± 14		V
CM Rejection Ratio	$R_S \leq 50\Omega$	70	100		70	100		dB
Power Supply Rejection Ratio	$R_S \leq 50\Omega$, $V_S = \pm 5V$ to $\pm 15V$	76	100		74	100		dB
Output Voltage Swing	$R_L \geq 10 \text{ k}\Omega$	± 12	± 14		± 12	± 14		V

DC Electrical Characteristic

($V_S = \pm 15V$, $I_{SET} = 10 \mu A$)

Parameter	Conditions	LM146			LM346			Units
		Min	Typ	Max	Min	Typ	Max	
Input Offset Voltage	$V_{CM} = 0V$, $R_S \leq 50\Omega$, $T_A = 25^\circ C$		0.5	5		0.5	7	mV
Input Bias Current	$V_{CM} = 0V$, $T_A = 25^\circ C$		7.5	20		7.5	100	nA
Supply Current (4 Op Amps)	$T_A = 25^\circ C$		140	250		140	300	μA
Gain Bandwidth Product	$T_A = 25^\circ C$	80	100		50	100		kHz

DC Electrical Characteristics

($V_S = \pm 1.5V$, $I_{SET} = 10 \mu A$)

Parameter	Conditions	LM146			LM346			Units
		Min	Typ	Max	Min	Typ	Max	
Input Offset Voltage	$V_{CM} = 0V$, $R_S \leq 50\Omega$, $T_A = 25^\circ C$		0.5	5		0.5	7	mV
Input CM Range	$T_A = 25^\circ C$	± 0.7			± 0.7			V
CM Rejection Ratio	$R_S \leq 50\Omega$, $T_A = 25^\circ C$		80			80		dB
Output Voltage Swing	$R_L \geq 10 \text{ k}\Omega$, $T_A = 25^\circ C$	± 0.6			± 0.6			V

Note 1: For supply voltages less than $\pm 15V$, the absolute maximum input voltage is equal to the supply voltage.

Note 2: The maximum power dissipation for these devices must be derated at elevated temperatures and is dictated by T_{JMAX} , θ_{JA} , and the ambient temperature, T_A . The maximum available power dissipation at any temperature is $P_d = (T_{JMAX} - T_A) / \theta_{JA}$ or the $25^\circ C$ P_{dMAX} , whichever is less.

Note 3: Any of the amplifier outputs can be shorted to ground indefinitely; however, more than one should not be simultaneously shorted as the maximum junction temperature will be exceeded.

Note 4: These specifications apply over the absolute maximum operating temperature range unless otherwise noted.

Note 5: Refer to RETS146X for LM146J military specifications.

Typical Performance Characteristics

Input Bias Current vs I_{SET}

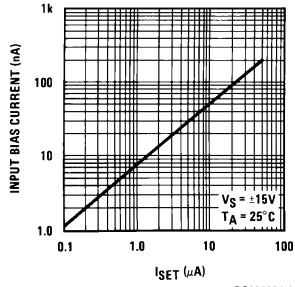

Supply Current vs I_{SET}

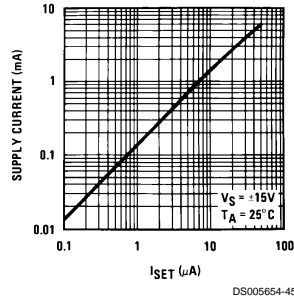

Open Loop Voltage Gain vs I_{SET}

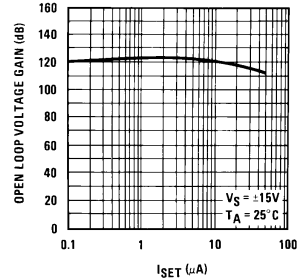

Slew Rate vs I_{SET}

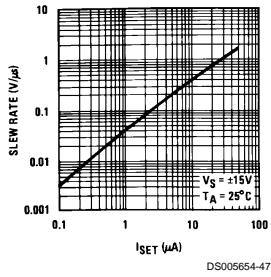

Gain Bandwidth Product vs I_{SET}

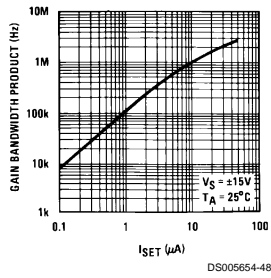

Phase Margin vs I_{SET}

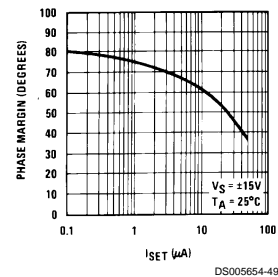

Input Offset Voltage vs I_{SET}

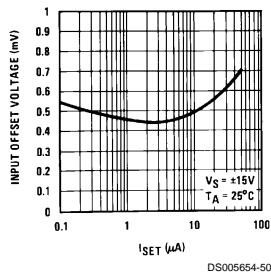

Common-Mode Rejection Ratio vs I_{SET}

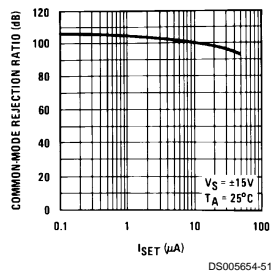

Power Supply Rejection Ratio vs I_{SET}

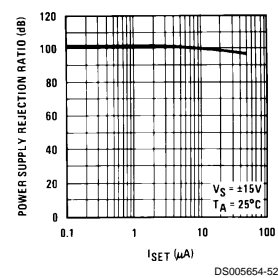

Typical Performance Characteristics (Continued)

Open Voltage Swing vs Supply Voltage

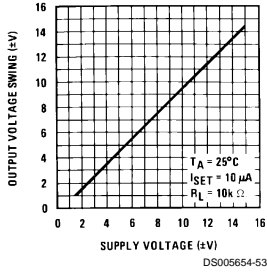

Input Voltage Range vs Supply Voltage

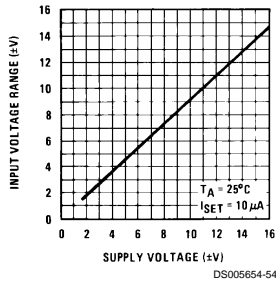

Input Bias Current vs Input Common-Mode Voltage

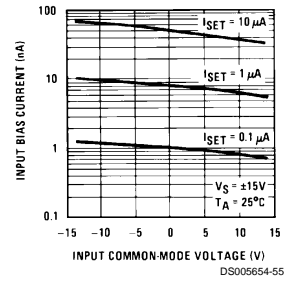

Input Bias Current vs Temperature

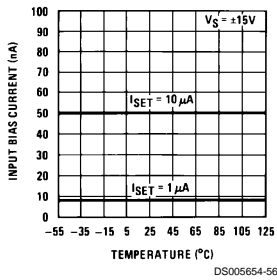

Input Offset Current vs Temperature

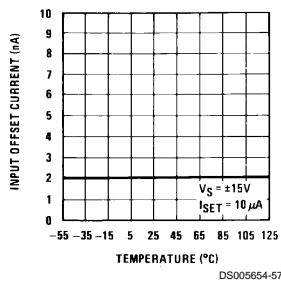

Supply Current vs Temperature

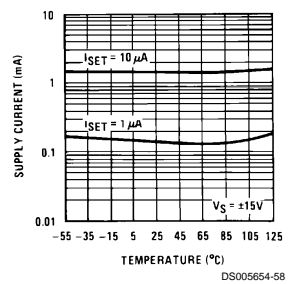

Open Loop Voltage Gain vs Temperature

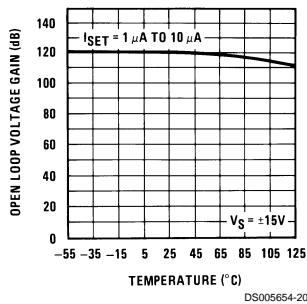

Gain Bandwidth Product vs Temperature

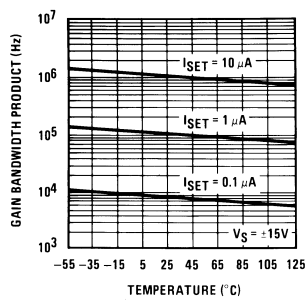

Slew Rate vs Temperature

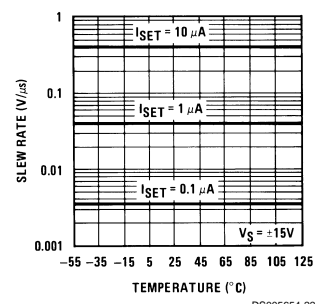

Typical Performance Characteristics (Continued)

Input Noise Voltage vs Frequency

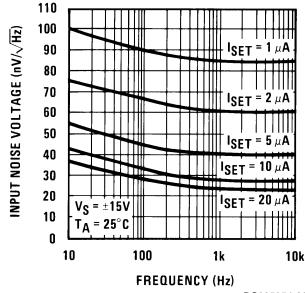

Input Noise Current vs Frequency

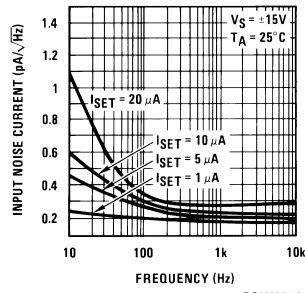

Power Supply Rejection Ratio vs Frequency

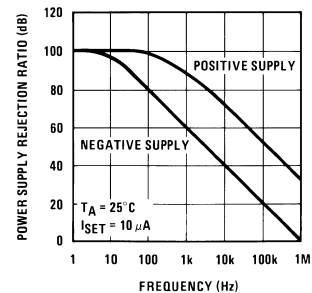

Voltage Follower Pulse Response

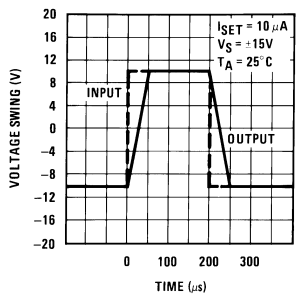

Voltage Follower Transient Response

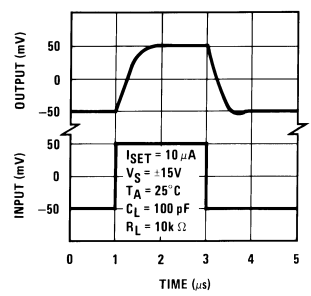

Transient Response Test Circuit

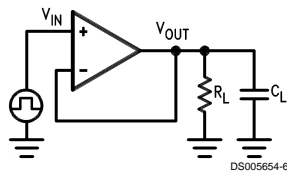

Application Hints

Avoid reversing the power supply polarity; the device will fail.

Common-Mode Input Voltage: The negative common-mode voltage limit is one diode drop above the negative supply voltage. Exceeding this limit on either input will result in an output phase reversal. The positive common-mode limit is typically 1V below the positive supply voltage. No output phase reversal will occur if this limit is exceeded by either input.

Output Voltage Swing vs I_{SET} : For a desired output voltage swing the value of the minimum load depends on the positive and negative output current capability of the op amp. The maximum available positive output current, (I_{CL+}), of the device increases with I_{SET} whereas the negative output current (I_{CL-}) is independent of I_{SET} . Figure 1 illustrates the above.

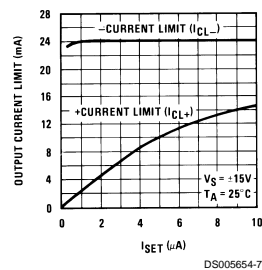
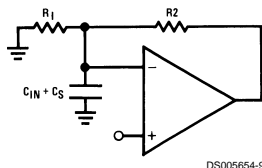

FIGURE 1. Output Current Limit vs I_{SET}

Application Hints (Continued)

Input Capacitance: The input capacitance, C_{IN} , of the LM146 is approximately 2 pF; any stray capacitance, C_S , (due to external circuit layout) will add to C_{IN} . When resistive or active feedback is applied, an additional pole is added to the open loop frequency response of the device. For instance with resistive feedback (Figure 2), this pole occurs at $\frac{1}{2\pi} (R_1 || R_2) (C_{IN} + C_S)$. Make sure that this pole occurs at least 2 octaves beyond the expected -3 dB frequency corner of the closed loop gain of the amplifier; if not, place a lead capacitor in the feedback such that the time constant of this capacitor and the resistance it parallels is equal to the $R_1(C_S + C_{IN})$, where R_1 is the input resistance of the circuit.



DS005654-9

FIGURE 2.

Temperature Effect on the GBW: The GBW (gain bandwidth product), of the LM146 is directly proportional to I_{SET} and inversely proportional to the absolute temperature. When using resistors to set the bias current, I_{SET} , of the device, the GBW product will decrease with increasing temperature. Compensation can be provided by creating an I_{SET} current directly proportional to temperature (see typical applications).

Isolation Between Amplifiers: The LM146 die is isothermally laid out such that crosstalk between *all* 4 amplifiers is in excess of -105 dB (DC). Optimum isolation (better than -110 dB) occurs between amplifiers A and D, B and C; that is, if amplifier A dissipates power on its output stage, amplifier D is the one which will be affected the least, and vice versa. Same argument holds for amplifiers B and C.

LM146 Typical Performance Summary: The LM146 typical behaviour is shown in Figure 3. The device is fully predictable. As the set current, I_{SET} , increases, the speed, the bias current, and the supply current increase while the noise

power decreases proportionally and the V_{OS} remains constant. The usable GBW range of the op amp is 10 kHz to 3.5–4 MHz.

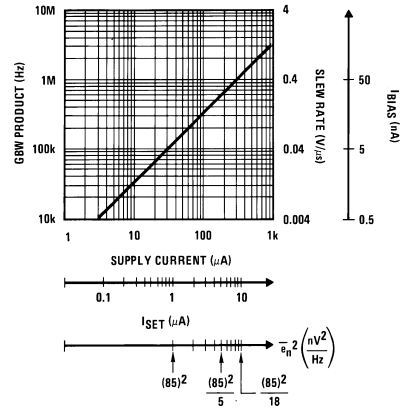

DS005654-8

FIGURE 3. LM146 Typical Characteristics

Low Power Supply Operation: The quad op amp operates down to $\pm 1.3V$ supply. Also, since the internal circuitry is biased through programmable current sources, no degradation of the device speed will occur.

Speed vs Power Consumption: LM146 vs LM4250 (single programmable). Through Figure 4, we observe that the LM146's power consumption has been optimized for GBW products above 200 kHz, whereas the LM4250 will reach a GBW of no more than 300 kHz. For GBW products below 200 kHz, the LM4250 will consume less power.

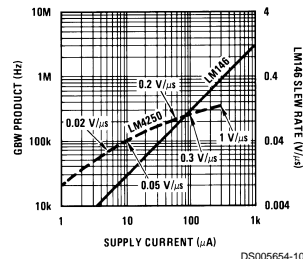

DS005654-10

FIGURE 4. LM146 vs LM4250

Typical Applications

Dual Supply or Negative Supply Biasing

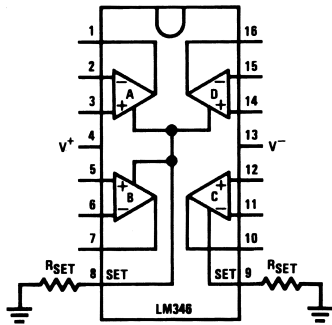

DS005654-39

$$I_{SET} \cong \frac{|V^-| - 0.6V}{R_{SET}}$$

Single (Positive) Supply Biasing

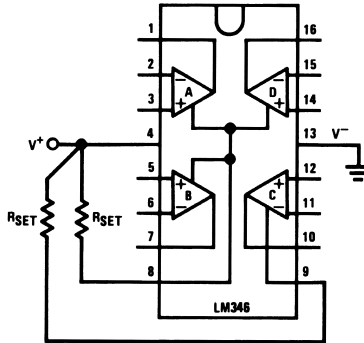

DS005654-11

$$I_{SET} \cong \frac{V^+ - 0.6V}{R_{SET}}$$

Current Source Biasing with Temperature Compensation

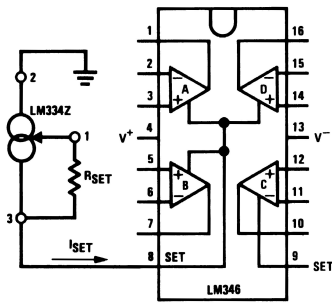

DS005654-40

$$I_{SET} = \frac{67.7 \text{ mV}}{R_{SET}}$$

• The LM334 provides an I_{SET} directly proportional to absolute temperature. This cancels the slight GBW product Temperature coefficient of the LM346.

Blasing all 4 Amplifiers with Single Current Source

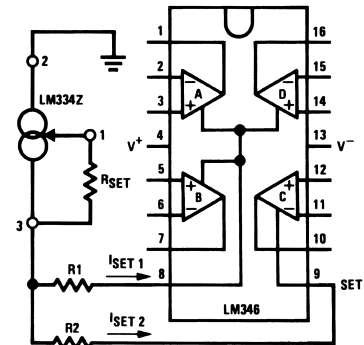

DS005654-41

$$\frac{I_{SET1}}{I_{SET2}} = \frac{R2}{R1}, \quad I_{SET1} + I_{SET2} = \frac{67.7 \text{ mV}}{R_{SET}}$$

• For $I_{SET1} = I_{SET2}$ resistors R1 and R2 are not required if a slight error between the 2 set currents can be tolerated. If not, then use $R1 = R2$ to create a 100 mV drop across these resistors.

Active Filters Applications

Basic (Non-Inverting "State Variable") Active Filter Building Block

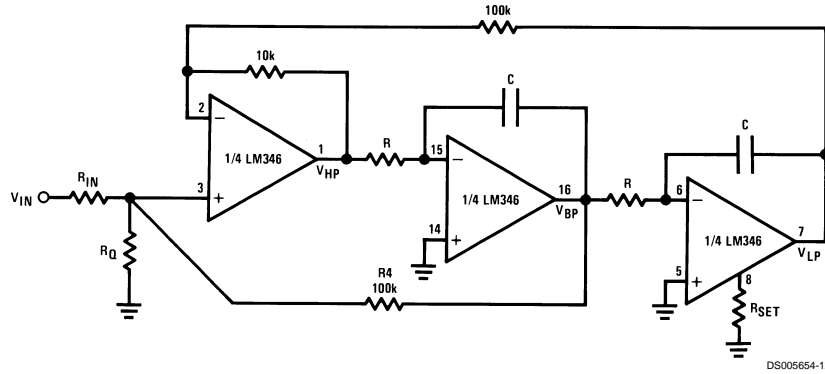

DS005654-12

- The LM146 quad programmable op amp is especially suited for active filters because of their adequate GBW product and low power consumption.

Circuit synthesis equations (for circuit analysis equations, consult with the LM148 data sheet).

Need to know desired: f_o = center frequency measured at the BP output

Q_o = quality factor measured at the BP output

H_o = gain at the output of interest (BP or HP or LP or all of them)

- Relation between different gains: $H_o(\text{BP}) = 0.316 \times Q_o \times H_o(\text{LP})$; $H_o(\text{LP}) = 10 \times H_o(\text{HP})$

$$\bullet R \times C = \frac{5.033 \times 10^{-2}}{f_o} \text{ (sec)}$$

$$\bullet \text{ For BP output: } R_Q = \left(\frac{3.478 Q_o - H_o(\text{BP})}{10^5} - \frac{H_o(\text{BP})}{10^5 \times 3.748 \times Q_o} \right)^{-1}; R_{IN} = \frac{\left(\frac{3.478 Q_o - 1}{H_o(\text{BP})} \right)}{\frac{1}{R_Q} + 10^{-5}}$$

$$\bullet \text{ For HP output: } R_Q = \frac{1.1 \times 10^5}{3.478 Q_o (1.1 - H_o(\text{HP})) - H_o(\text{HP})}; R_{IN} = \frac{\frac{1.1}{H_o(\text{HP})} - 1}{\frac{1}{R_Q} + 10^{-5}}$$

$$\bullet \text{ For LP output: } R_Q = \frac{11 \times 10^5}{3.478 Q_o (11 - H_o(\text{LP})) - H_o(\text{LP})}; R_{IN} = \frac{\frac{11}{H_o(\text{LP})} - 1}{\frac{1}{R_Q} + 10^{-5}}$$

- For BR (notch) output: Use the 4th amplifier of the LM146 to sum the LP and HP outputs of the basic filter.

DS005654-33

Note. All resistor values are given in ohms.

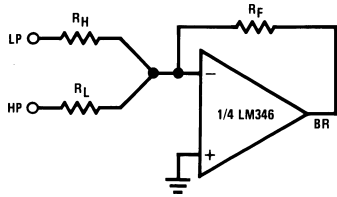

DS005654-13

$$\sqrt{\frac{R_H}{R_L}} = 0.316 \frac{f_{\text{notch}}}{f_o}$$

DS005654-34

Active Filters Applications (Continued)

Determine R_F according to the desired gains: $H_0(BR) \Big|_{f < f_{notch}} = \frac{R_F}{R_L} H_0(LP)$, $H_0(BR) \Big|_{f > f_{notch}} = \frac{R_F}{R_H} H_0(LP)$

- **Where to use amplifier C:** Examine the above gain relations and determine the dynamics of the filter. Do not allow slew rate limiting in any output (V_{HP} , V_{BP} , V_{LP}), that is:

$$V_{IN(peak)} < 63.66 \times 10^3 \times \frac{I_{SET}}{10 \mu A} \times \frac{1}{f_o \times H_o} \text{ (Volts)}$$

If necessary, use amplifier C, biased at higher I_{SET} , where you get the largest output swing.

Deviation from Theoretical Predictions: Due to the finite GBW products of the op amps the f_o , Q_o will be slightly different from the theoretical predictions.

$$f_{real} \approx \frac{f_o}{1 + \frac{2f_o}{GBW}}, \quad Q_{real} \approx \frac{Q_o}{1 - \frac{3.2f_o \times Q_o}{GBW}}$$

DS00654-35

A Simple-to-Design BP, LP Filter Building Block

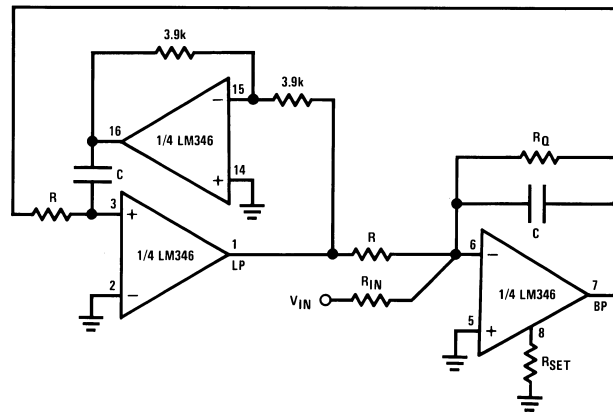

DS00654-14

- If resistive biasing is used to set the LM346 performance, the Q_o of this filter building block is nearly insensitive to the op amp's GBW product temperature drift; it has also better noise performance than the state variable filter.

Circuit Synthesis Equations

$$H_0(BP) = Q_o H_0(LP); \quad R \times C = \frac{0.159}{f_o}; \quad R_Q = Q_o \times R; \quad R_{IN} = \frac{R_Q}{H_0(BP)} = \frac{R}{H_0(LP)}$$

DS00654-36

- For the eventual use of amplifier C, see comments on the previous page.

Active Filters Applications (Continued)

A 3-Amplifier Notch Filter (or Elliptic Filter Building Block)

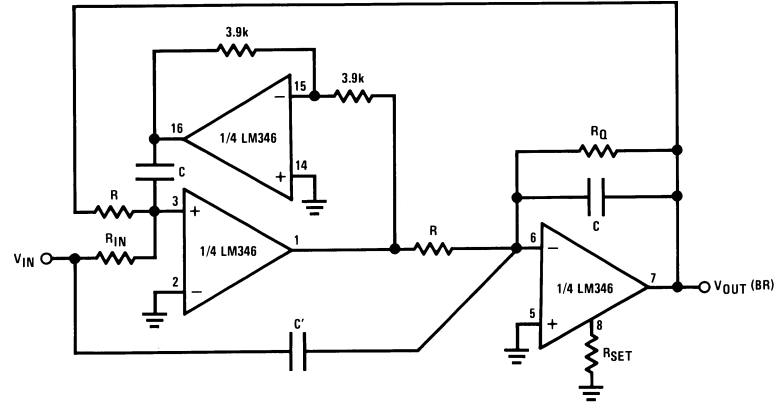

DS005654-15

Circuit Synthesis Equations

$$R \times C = \frac{0.159}{f_o}; R_o = Q_o \times R; R_{IN} = \frac{0.159 \times f_o}{C' \times f_{notch}^2}$$

$$H_o(BR)|_{f \ll f_{notch}} = \frac{R}{R_{IN}}; H_o(BR)|_{f \gg f_{notch}} = \frac{C'}{C}$$

DS005654-37

•For nothing but a notch output: $R_{IN}=R$, $C'=C$.

Capacitorless Active Filters (Basic Circuit)

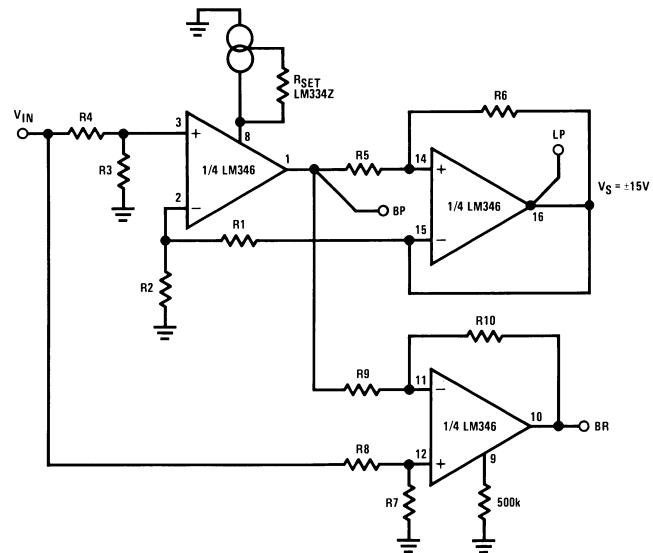

DS005654-16

Active Filters Applications (Continued)

• This is a BP, LP, BR filter. The filter characteristics are created by using the tunable frequency response of the LM346.

• **Limitations:** $Q_o < 10$, $f_o \times Q_o < 1.5$ MHz, output voltage should not exceed $V_{peak(out)} \leq \frac{63.66 \times 10^3}{f_o} \times \frac{I_{SET}(\mu A)}{10 \mu A}$ (V)

• Design equations: $a = \frac{R6 + R5}{R6}$, $b = \frac{R2}{R1 + R2}$, $c = \frac{R3}{R3 + R4}$, $d = \frac{R7}{R8 + R7}$, $e = \frac{R10}{R9 + R10}$, $f_{o(BP)} = f_u \sqrt{\frac{b}{a}}$, $H_{o(BP)} = a \times c$, $H_{o(LP)} = \frac{c}{b}$, $Q_o = \sqrt{a \times b}$

$f_{o(BR)} = f_{o(BP)} \left(1 - \frac{c}{b}\right) \cong f_{o(BP)}$ ($C \ll 1$) provided that $d = H_{o(BP)} \times e$, $H_{o(BR)} = \frac{R10}{R9}$.

• Advantage: $f_o Q_o$, H_o can be independently adjusted; that is, the filter is extremely easy to tune.

• Tuning procedure (ex. BP tuning)

DS005654-38

1. Pick up a convenient value for b; ($b < 1$)
2. Adjust Q_o through R5
3. Adjust $H_{o(BP)}$ through R4
4. Adjust f_o through R_{SET} . This adjusts the unity gain frequency (f_u) of the op amp.

A 4th Order Butterworth Low Pass Capacitorless Filter

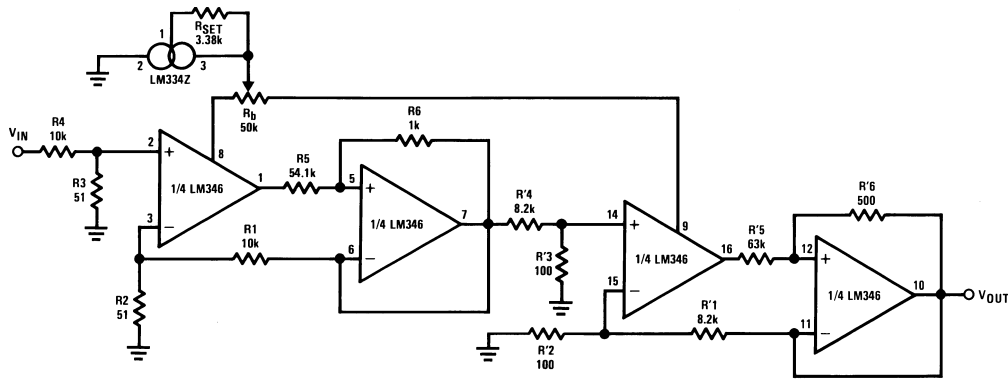

DS005654-17

Ex: $f_c = 20$ kHz, H_o (gain of the filter) = 1, $Q_{o1} = 0.541$, $Q_{o2} = 1.306$.

• Since for this filter the GBW product of all 4 amplifiers has been designed to be the same (~1 MHz) only one current source can be used to bias the circuit. Fine tuning can be further accomplished through R_b .

Miscellaneous Applications

A Unity Gain Follower with Bias Current Reduction

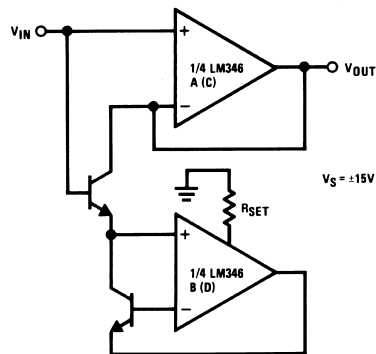

DS005654-18

• For better performance, use a matched NPN pair.

Miscellaneous Applications (Continued)

Circuit Shutdown

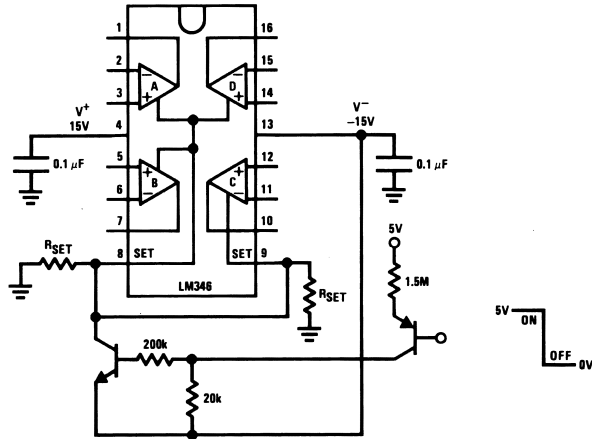

DS005654-42

• By pulling the SET pin(s) to V^- the op amp(s) shuts down and its output goes to a high impedance state. According to this property, the LM348 can be used as a very low speed analog switch.

Voice Activated Switch and Amplifier

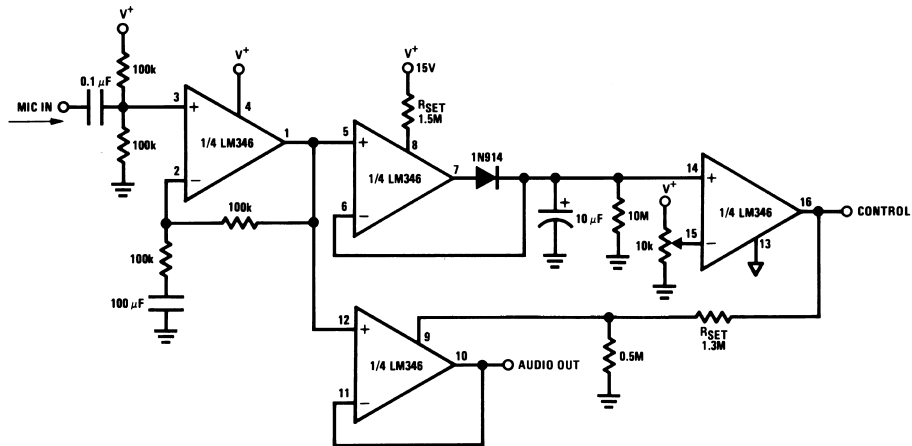

DS005654-43

Miscellaneous Applications (Continued)

X10 Micropower Instrumentation Amplifier with Buffered Input Guarding

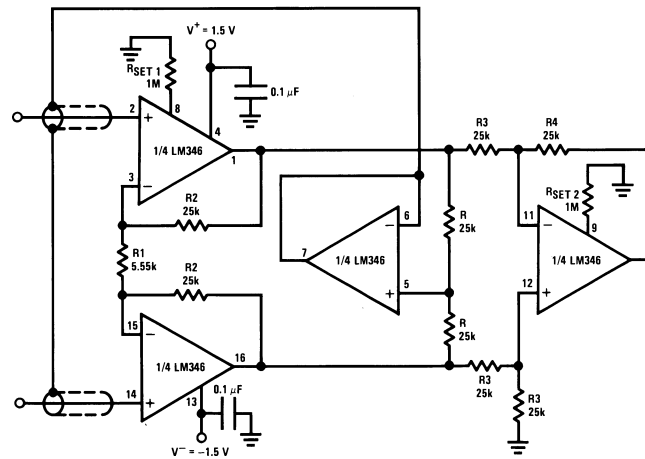

DS00654-19

- CMRR: 100 dB (typ)
- Power dissipation: 0.4 mW

Physical Dimensions inches (millimeters) unless otherwise noted

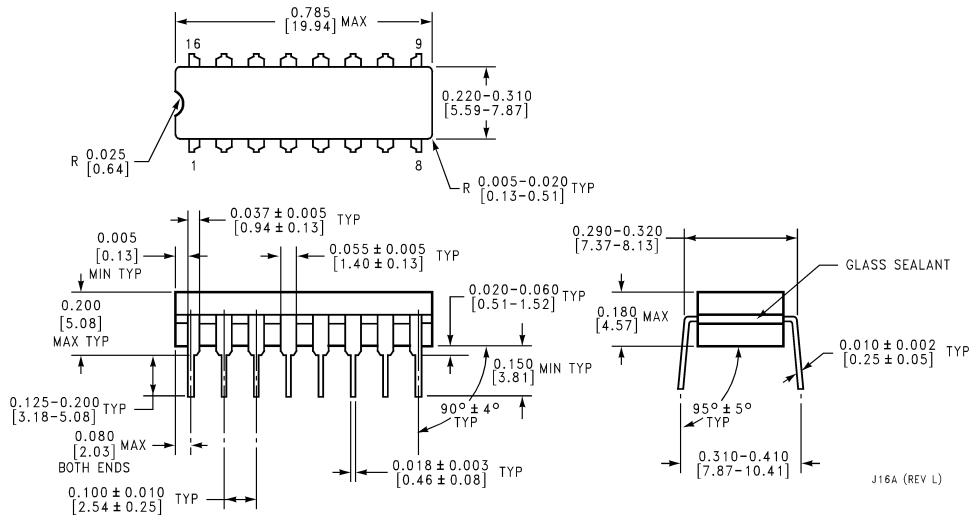

Cavity Dual-In-Line Package (J)
Order Number LM146J, LM146J/883
NS Package Number J16A

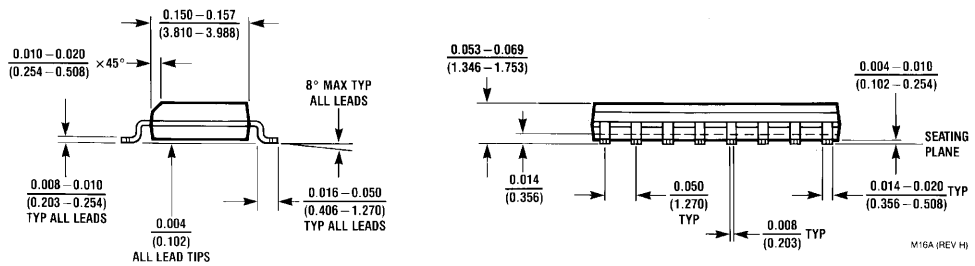
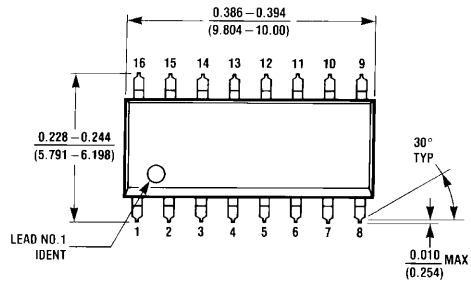

S.O. Package (M)
Order Number LM346M
NS Package Number M16A

Physical Dimensions inches (millimeters) unless otherwise noted (Continued)

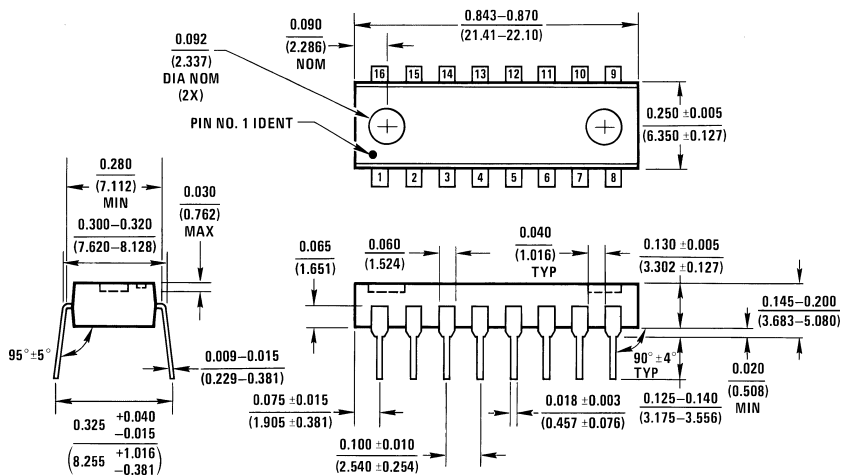

Molded Dual-In-Line Package (N)
Order Number LM346N
NS Package Number N16A

N16A (REV E)

LIFE SUPPORT POLICY

NATIONAL'S PRODUCTS ARE NOT AUTHORIZED FOR USE AS CRITICAL COMPONENTS IN LIFE SUPPORT DEVICES OR SYSTEMS WITHOUT THE EXPRESS WRITTEN APPROVAL OF THE PRESIDENT AND GENERAL COUNSEL OF NATIONAL SEMICONDUCTOR CORPORATION. As used herein:

1. Life support devices or systems are devices or systems which, (a) are intended for surgical implant into the body, or (b) support or sustain life, and whose failure to perform when properly used in accordance with instructions for use provided in the labeling, can be reasonably expected to result in a significant injury to the user.
2. A critical component is any component of a life support device or system whose failure to perform can be reasonably expected to cause the failure of the life support device or system, or to affect its safety or effectiveness.

National Semiconductor Corporation
Americas
Tel: 1-800-272-9959
Fax: 1-800-737-7018
Email: support@nsc.com

National Semiconductor Europe
Fax: +49 (0) 1 80-530 85 86
Email: europe.support@nsc.com
Deutsch Tel: +49 (0) 1 80-530 85 85
English Tel: +49 (0) 1 80-532 78 32
Français Tel: +49 (0) 1 80-532 93 58
Italiano Tel: +49 (0) 1 80-534 16 80

National Semiconductor Asia Pacific Customer Response Group
Tel: 65-2544466
Fax: 65-2504466
Email: sea.support@nsc.com

National Semiconductor Japan Ltd.
Tel: 81-3-5639-7560
Fax: 81-3-5639-7507

www.national.com