

LM185-2.5/LM285-2.5/LM385-2.5 Micropower Voltage Reference Diode

General Description

The LM185-2.5/LM285-2.5/LM385-2.5 are micropower 2-terminal band-gap voltage regulator diodes. Operating over a 20 μ A to 20 mA current range, they feature exceptionally low dynamic impedance and good temperature stability. On-chip trimming is used to provide tight voltage tolerance. Since the LM-185-2.5 band-gap reference uses only transistors and resistors, low noise and good long term stability result.

Careful design of the LM185-2.5 has made the device exceptionally tolerant of capacitive loading, making it easy to use in almost any reference application. The wide dynamic operating range allows its use with widely varying supplies with excellent regulation.

The extremely low power drain of the LM185-2.5 makes it useful for micropower circuitry. This voltage reference can be used to make portable meters, regulators or general purpose analog circuitry with battery life approaching shelf life. Further, the wide operating current allows it to replace older references with a tighter tolerance part. For applications requiring 1.2V see LM185-1.2.

The LM185-2.5 is rated for operation over a -55°C to 125°C temperature range while the LM285-2.5 is rated -40°C to 85°C and the LM385-2.5 0°C to 70°C . The LM185-2.5/LM285-2.5 are available in a hermetic TO-46 package and the LM285-2.5/LM385-2.5 are also available in a low-cost TO-92 molded package, as well as S.O. and SOT-23. The LM185-2.5 is also available in a hermetic leadless chip carrier package.

Features

- ± 20 mV ($\pm 0.8\%$) max. initial tolerance (A grade)
- Operating current of 20 μ A to 20 mA
- 0.6Ω dynamic impedance (A grade)
- Low temperature coefficient
- Low voltage reference — 2.5V
- 1.2V device and adjustable device also available — LM185-1.2 series and LM185 series, respectively

Connection Diagrams

TO-92
Plastic Package

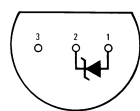

DS005519-8

Bottom View

Order Number LM285Z-2.5,
LM285BXZ-2.5, LM285BYZ-2.5
LM385Z-2.5, LM385AXZ-2.5
LM385AYZ-2.5, LM385BZ-2.5,
LM385BXZ-2.5 or LM385BYZ-2.5
See NS Package Number Z03A

SO Package

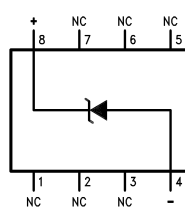

DS005519-11

Order Number LM285M-2.5,
LM285BXM-2.5, LM285BYM-2.5
LM385M-2.5, LM385BM-2.5
LM385BXM-2.5 or LM385BYM-2.5
See NS Package Number M08A

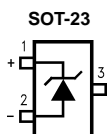

DS005519-29

* Pin 3 is attached to the Die Attach Pad (DAP) and should be connected to Pin 2 or left floating.

Order Number LM385M3-2.5
See NS Package Number MA03B

Connection Diagrams (Continued)

LCC
Leadless Chip Carrier

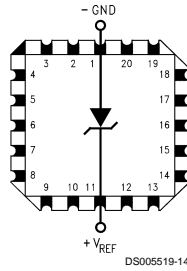

Order Number LM185E-2.5/883
See NS Package Number E20A

TO-46
Metal Can Package

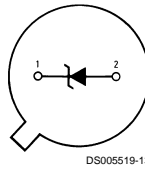

Bottom View
Order Number LM185H-2.5,
LM185H-2.5/883, LM185BXH-2.5,
LM185BXH-2.5/883, LM185BYH-2.5,
LM185BYH2.5/883, LM285H-2.5,
or LM285BYH-2.5
See NS Package Number H02A

Absolute Maximum Ratings (Notes 1, 2)

If Military/Aerospace specified devices are required, please contact the National Semiconductor Sales Office/Distributors for availability and specifications.

Reverse Current	30 mA
Forward Current	10 mA
Operating Temperature Range (Note 3)	
LM185-2.5	-55°C to + 125°C
LM285-2.5	-40°C to + 85°C
LM385-2.5	0°C to 70°C
Storage Temperature	-55°C to + 150°C

Soldering Information	
TO-92 Package (10 sec.)	260°C
TO-46 Package (10 sec.)	300°C
SO and SOT Package	
Vapor Phase (60 sec.)	215°C
Infrared (15 sec.)	220°C

See AN-450 "Surface Mounting Methods and Their Effect on Product Reliability" for other methods of soldering surface mount devices.

Electrical Characteristics

(Note 4)

Parameter	Conditions	Typ	LM385A-2.5 LM385AX-2.5 LM385AY-2.5		Units (Limits)
			Tested Limit (Note 5)	Design Limit (Note 6)	
Reverse Breakdown Voltage	$I_R = 100 \mu\text{A}$	2.500	2.480		V(Min)
		2.500	2.520	2.470 2.530	V(Max) V(Min) V(Max)
Minimum Operating Current		12	18	20	μA (Max)
Reverse Breakdown Voltage Change with Current	$I_{\text{MIN}} \leq I_R \leq 1\text{mA}$		1	1.5	mV (Max)
	$1\text{ mA} \leq I_R \leq 20\text{ mA}$		10	20	mV (Max)
Reverse Dynamic Impedance	$I_R = 100 \mu\text{A}$, $f = 20\text{ Hz}$	0.2		0.6 1.5	Ω
Wideband Noise (rms)	$I_R = 100 \mu\text{A}$ $10\text{ Hz} \leq f \leq 10\text{ kHz}$	120			μV
Long Term Stability	$I_R = 100 \mu\text{A}$, $T = 1000\text{ Hr}$, $T_A = 25^\circ\text{C} \pm 0.1^\circ\text{C}$	20			ppm
Average Temperature Coefficient (Note 7)	$I_{\text{MIN}} \leq I_R \leq 20\text{ mA}$ X Suffix Y Suffix All Others		30		ppm/°C (Max)
			50		
				150	

Electrical Characteristics (Continued)									
Parameter	Conditions	Typ	LM185-2.5 LM185BX-2.5 LM185BY-2.5 LM285-2.5 LM285BX-2.5 LM285BY-2.5		LM385B-2.5 LM385BX-2.5 LM385BY-2.5		LM385-2.5		Units (Limit)
			Tested Limit (Note 5) (Note 8)	Design Limit (Note 6)	Tested Limit (Note 5)	Design Limit (Note 6)	Tested Limit (Note 5)	Design Limit (Note 6)	
Reverse Breakdown Voltage	$T_A = 25^\circ\text{C}$, $20\ \mu\text{A} \leq I_R \leq 20\ \text{mA}$	2.5	2.462 2.538		2.462 2.538		2.425 2.575		V(Min) V(Max)
Minimum Operating Current		13	20	30	20	30	20	30	μA (Max)
	LM385M3-2.5						15	20	
Reverse Breakdown Voltage Change with Current	$20\ \mu\text{A} \leq I_R \leq 1\ \text{mA}$		1	1.5	2.0	2.5	2.0	2.5	mV (Max)
	$1\ \text{mA} \leq I_R \leq 20\ \text{mA}$		10	20	20	25	20	25	mV (Max)
Reverse Dynamic Impedance	$I_R = 100\ \mu\text{A}$, $f = 20\ \text{Hz}$	1							Ω
Wideband Noise (rms)	$I_R = 100\ \mu\text{A}$, $10\ \text{Hz} \leq f \leq 10\ \text{kHz}$	120							μV
Long Term Stability	$I_R = 100\ \mu\text{A}$, $T = 1000\ \text{Hr}$, $T_A = 25^\circ\text{C} \pm 0.1^\circ\text{C}$	20							ppm
Average Temperature Coefficient (Note 7)	$I_R = 100\ \mu\text{A}$								
	X Suffix		30		30				ppm/ $^\circ\text{C}$
	Y Suffix		50		50				ppm/ $^\circ\text{C}$
All Others			150		150		150	ppm/ $^\circ\text{C}$ (Max)	

Note 1: Absolute Maximum Ratings indicate limits beyond which damage to the device may occur. Operating Ratings indicate conditions for which the device is intended to be functional, but do not guarantee specific performance limits. For guaranteed specifications and test conditions, see the Electrical Characteristics. The guaranteed specifications apply only for the test conditions listed.

Note 2: Refer to RETS185H-2.5 for military specifications.

Note 3: For elevated temperature operation, $T_{J\ \text{MAX}}$ is:

LM185	150°C
LM285	125°C
LM385	100°C

Thermal Resistance	TO-92	TO-46	SO-8	SOT-23
θ_{ja} (Junction to Ambient)	180°C/W (0.4" Leads) 170°C/W (0.125" Leads)	440°C/W	165°C/W	283°C/W
θ_{jc} (Junction to Case)	N/A	80°C/W	N/A	N/A

Note 4: Parameters identified with boldface type apply at temperature extremes. All other numbers apply at $T_A = T_J = 25^\circ\text{C}$.

Note 5: Guaranteed and 100% production tested.

Note 6: Guaranteed, but not 100% production tested. These limits are not used to calculate average outgoing quality levels.

Note 7: The average temperature coefficient is defined as the maximum deviation of reference voltage at all measured temperatures between the operating T_{MAX} and T_{MIN} , divided by $T_{\text{MAX}} - T_{\text{MIN}}$. The measured temperatures are -55°C , -40°C , 0°C , 25°C , 70°C , 85°C , 125°C .

Note 8: A military RETS electrical specification available on request.

Typical Performance Characteristics

Reverse Characteristics

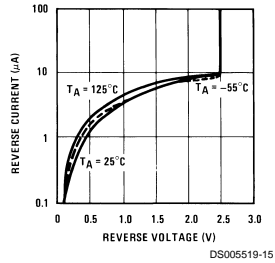

Reverse Characteristics

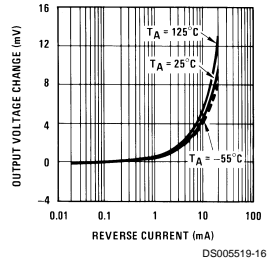

Forward Characteristics

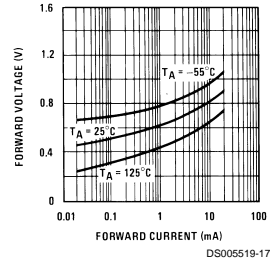

Temperature Drift

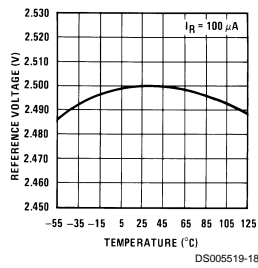

Reverse Dynamic Impedance

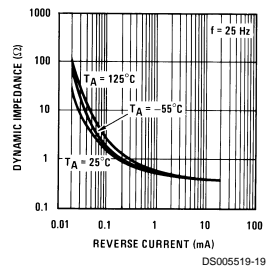

Reverse Dynamic Impedance

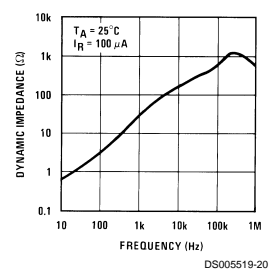

Noise Voltage

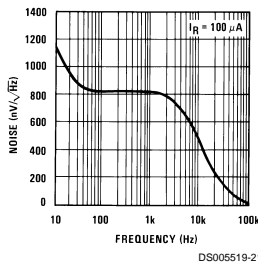

Filtered Output Noise

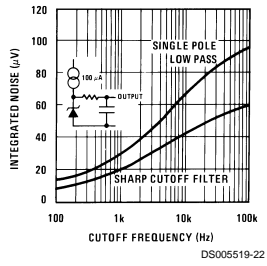

Response Time

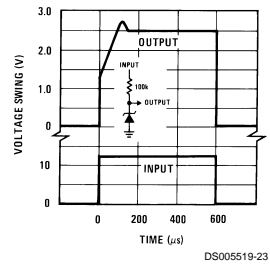

Applications

Wide Input Range Reference

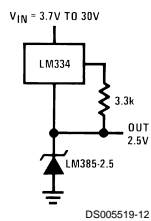

Micropower Reference from 9V Battery

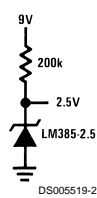

LM385-2.5 Applications

LM385-2.5 Applications (Continued)

Micropower 5V Reference (Note 9)

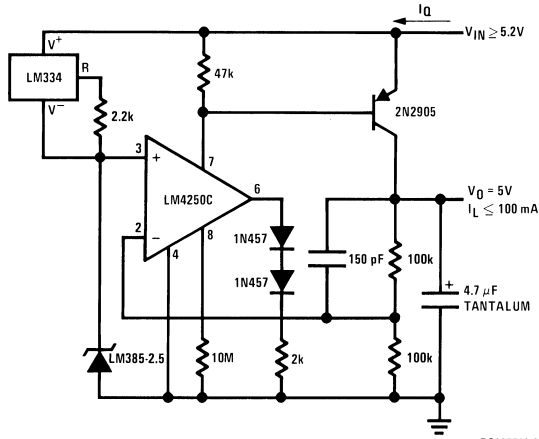

Note 9: $I_Q \cong 40 \mu A$

DS005519-9

Micropower 10V Reference (Note 10)

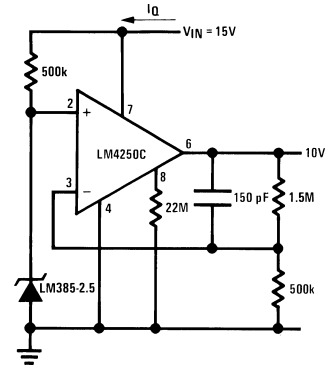

Note 10: $I_Q \cong 30 \mu A$ standby current

DS005519-10

LM385-2.5 Applications (Continued)

Precision 1 μ A to 1 mA Current Sources

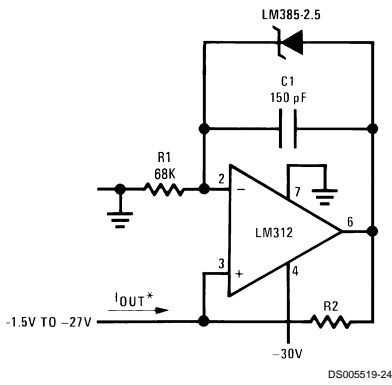

$$I_{OUT} = \frac{2.5V}{R2}$$

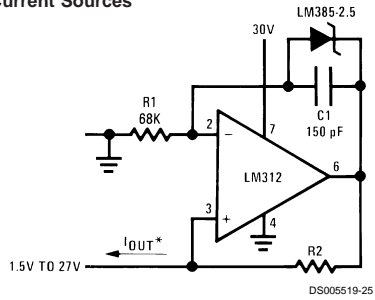

METER THERMOMETERS

0°C–100°C Thermometer

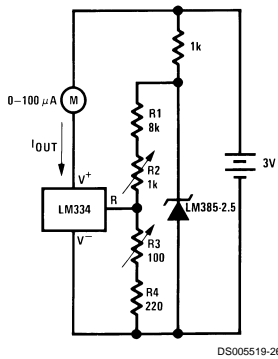

Calibration

1. Short LM385-2.5, adjust R3 for $I_{OUT} = \text{temp}$ at $1 \mu A/^{\circ}K$
2. Remove short, adjust R2 for correct reading in centigrade

0°F–50°F Thermometer

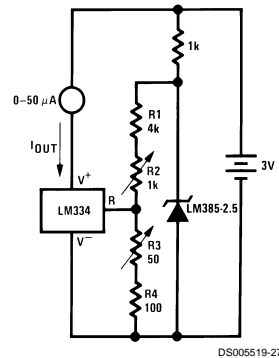

Calibration

1. Short LM385-2.5, adjust R3 for $I_{OUT} = \text{temp}$ at $1.8 \mu A/^{\circ}K$
2. Remove short, adjust R2 for correct reading in °F

LM385-2.5 Applications (Continued)

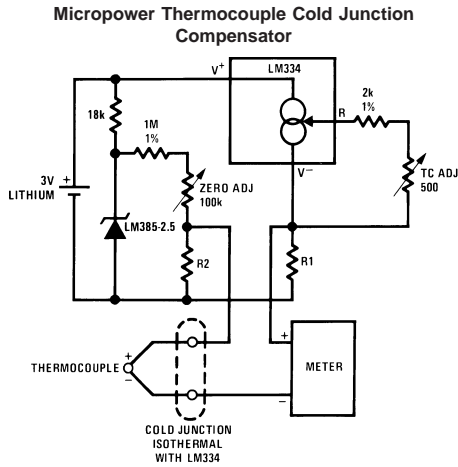

Adjustment Procedure

1. Adjust TC ADJ pot until voltage across R1 equals Kelvin temperature multiplied by the thermocouple Seebeck coefficient.
2. Adjust zero ADJ pot until voltage across R2 equals the thermocouple Seebeck coefficient multiplied by 273.2.

Thermocouple Type	Seebeck Co-efficient ($\mu\text{V}/^\circ\text{C}$)	R1 (Ω)	R2 (Ω)	Voltage Across R1 @25°C (mV)	Voltage Across R2 (mV)
J	52.3	523	1.24k	15.60	14.32
T	42.8	432	1k	12.77	11.78
K	40.8	412	953 Ω	12.17	11.17
S	6.4	63.4	150 Ω	1.908	1.766

Typical supply current 50 μA

Improving Regulation of Adjustable Regulators

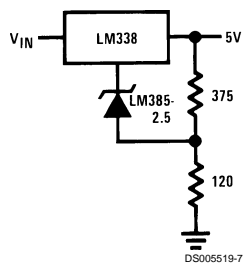

Schematic Diagram

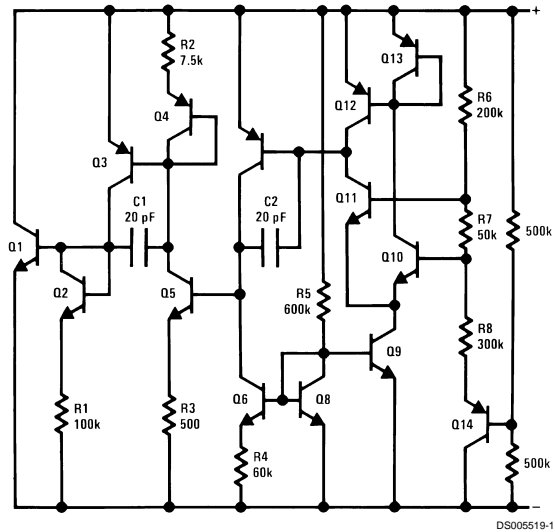

LM185-2.5/LM285-2.5/LM385-2.5

Physical Dimensions inches (millimeters) unless otherwise noted

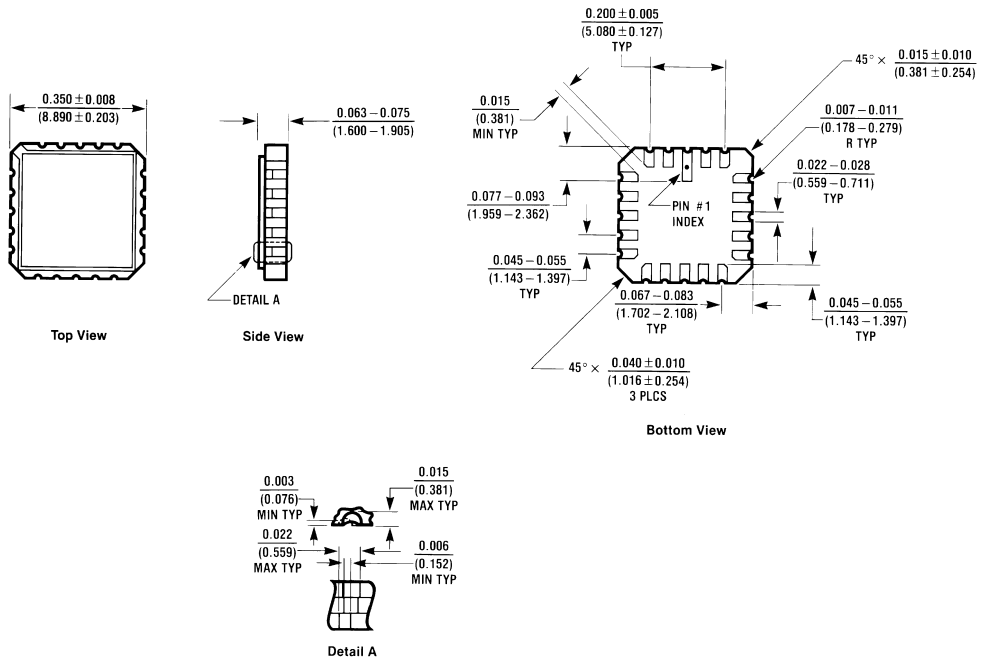

E20A (REV D)

Order Number LM185E-2.5/883
 NS Package Number E20A

Physical Dimensions inches (millimeters) unless otherwise noted (Continued)

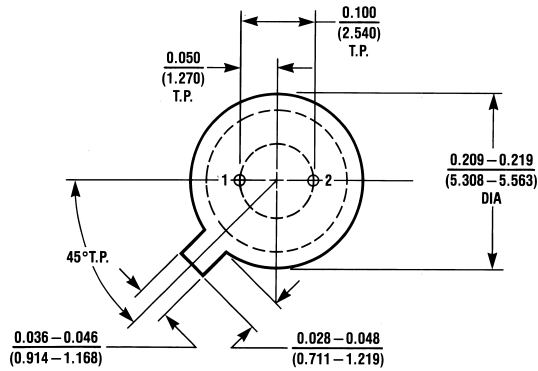
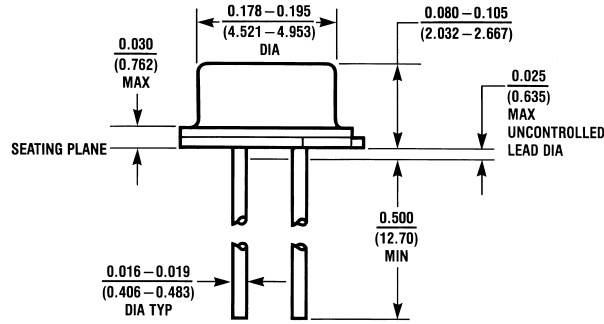

H02A (REV C)

TO-46 Metal Can Package (H)
Order Number LM185H-2.5, LM185H-2.5/883, LM185BXH-2.5, LM185BXH-2.5/883,
LM185BYH-2.5, LM185BYH-2.5/883, LM285H-2.5, or LM285BYH-2.5
NS Package Number H02A

Physical Dimensions inches (millimeters) unless otherwise noted (Continued)

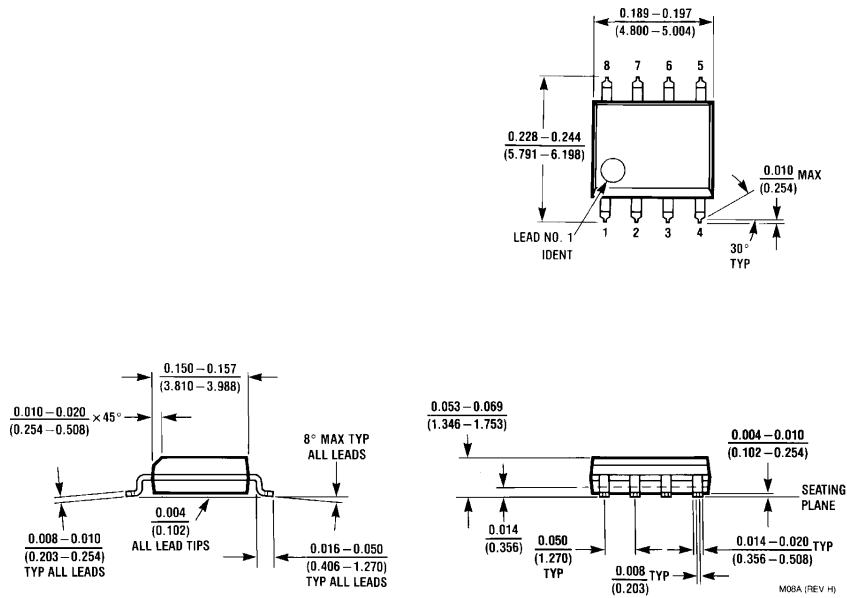

Small Outline (SO-8) Package (M)
Order Number LM285M-2.5, LM285BXM-2.5, LM285BYM-2.5,
LM385M-2.5, LM385BM-2.5, LM385BXM-2.5 or LM385BYM-2.5
NS Package Number M08A

Physical Dimensions inches (millimeters) unless otherwise noted (Continued)

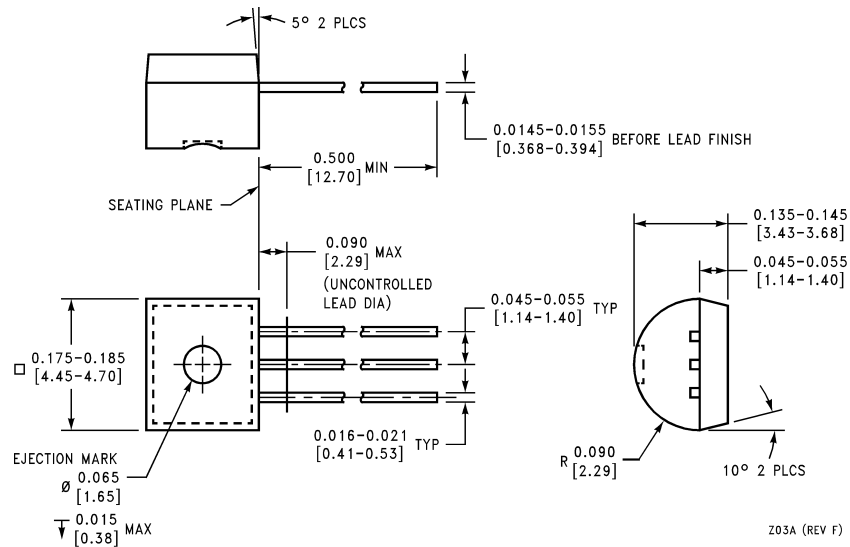

TO-92 Plastic Package (Z)
Order Number LM285Z-2.5, LM285BXZ-2.5, LM285BYZ-2.5,
LM385Z-2.5, LM385AXZ-2.5, LM385AYZ-2.5,
LM385BZ-2.5, LM385BXZ-2.5 or LM385BYZ-2.5
NS Package Number Z03A

Z03A (REV F)

LIFE SUPPORT POLICY

NATIONAL'S PRODUCTS ARE NOT AUTHORIZED FOR USE AS CRITICAL COMPONENTS IN LIFE SUPPORT DEVICES OR SYSTEMS WITHOUT THE EXPRESS WRITTEN APPROVAL OF THE PRESIDENT AND GENERAL COUNSEL OF NATIONAL SEMICONDUCTOR CORPORATION. As used herein:

1. Life support devices or systems are devices or systems which, (a) are intended for surgical implant into the body, or (b) support or sustain life, and whose failure to perform when properly used in accordance with instructions for use provided in the labeling, can be reasonably expected to result in a significant injury to the user.
2. A critical component is any component of a life support device or system whose failure to perform can be reasonably expected to cause the failure of the life support device or system, or to affect its safety or effectiveness.



National Semiconductor Corporation
Americas
Tel: 1-800-272-9959
Fax: 1-800-737-7018
Email: support@nsc.com

National Semiconductor Europe
Fax: +49 (0) 1 80-530 85 86
Email: europe.support@nsc.com
Deutsch Tel: +49 (0) 1 80-530 85 85
English Tel: +49 (0) 1 80-532 78 32
Français Tel: +49 (0) 1 80-532 93 58
Italiano Tel: +49 (0) 1 80-534 16 80

National Semiconductor Asia Pacific Customer Response Group
Tel: 65-2544466
Fax: 65-2504466
Email: sea.support@nsc.com

National Semiconductor Japan Ltd.
Tel: 81-3-5639-7560
Fax: 81-3-5639-7507

www.national.com