

## LM741 Operational Amplifier

### General Description

The LM741 series are general purpose operational amplifiers which feature improved performance over industry standards like the LM709. They are direct, plug-in replacements for the 709C, LM201, MC1439 and 748 in most applications. The amplifiers offer many features which make their application nearly foolproof: overload protection on the input and output, no latch-up when the common mode range is exceeded, as well as freedom from oscillations.

The LM741C/LM741E are identical to the LM741/LM741A except that the LM741C/LM741E have their performance guaranteed over a 0°C to +70°C temperature range, instead of -55°C to +125°C.

### Schematic Diagram

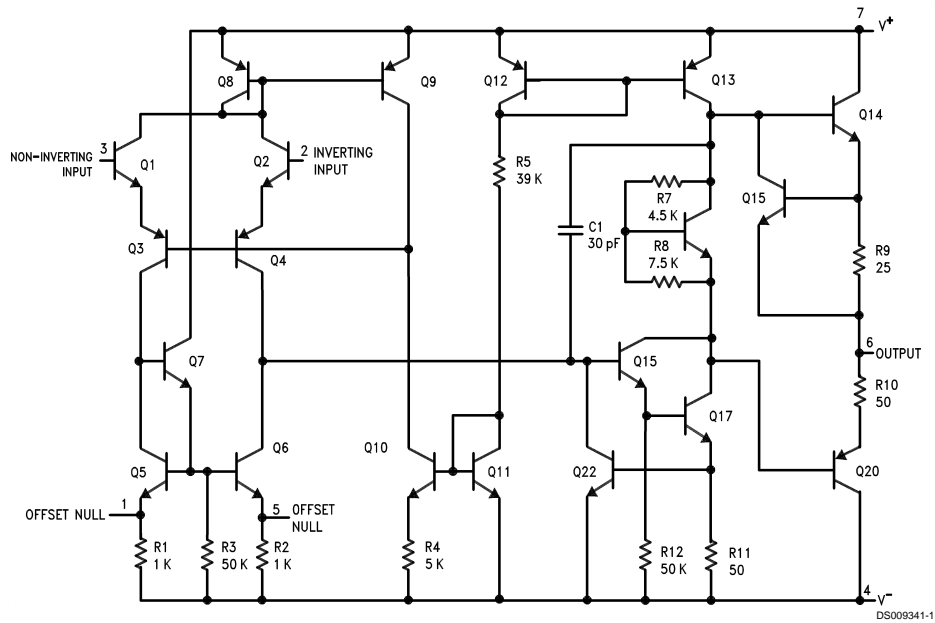

Offset Nulling Circuit

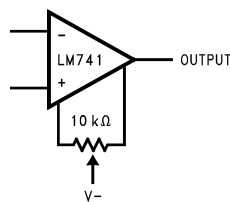

## Absolute Maximum Ratings (Note 1)

If Military/Aerospace specified devices are required, please contact the National Semiconductor Sales Office/Distributors for availability and specifications.

(Note 6)

	LM741A	LM741E	LM741	LM741C
Supply Voltage	±22V	±22V	±22V	±18V
Power Dissipation (Note 2)	500 mW	500 mW	500 mW	500 mW
Differential Input Voltage	±30V	±30V	±30V	±30V
Input Voltage (Note 3)	±15V	±15V	±15V	±15V
Output Short Circuit Duration	Continuous	Continuous	Continuous	Continuous
Operating Temperature Range	-55°C to +125°C	0°C to +70°C	-55°C to +125°C	0°C to +70°C
Storage Temperature Range	-65°C to +150°C	-65°C to +150°C	-65°C to +150°C	-65°C to +150°C
Junction Temperature	150°C	100°C	150°C	100°C
Soldering Information				
N-Package (10 seconds)	260°C	260°C	260°C	260°C
J- or H-Package (10 seconds)	300°C	300°C	300°C	300°C
M-Package				
Vapor Phase (60 seconds)	215°C	215°C	215°C	215°C
Infrared (15 seconds)	215°C	215°C	215°C	215°C
See AN-450 "Surface Mounting Methods and Their Effect on Product Reliability" for other methods of soldering surface mount devices.				
ESD Tolerance (Note 7)	400V	400V	400V	400V

## Electrical Characteristics (Note 4)

Parameter	Conditions	LM741A/LM741E			LM741			LM741C			Units
		Min	Typ	Max	Min	Typ	Max	Min	Typ	Max	
Input Offset Voltage	$T_A = 25^\circ\text{C}$					1.0	5.0		2.0	6.0	mV
	$R_S \leq 10\text{ k}\Omega$		0.8	3.0							mV
	$R_S \leq 50\Omega$			4.0			6.0			7.5	mV
Average Input Offset Voltage Drift	$T_{AMIN} \leq T_A \leq T_{AMAX}$			15							$\mu\text{V}/^\circ\text{C}$
	$R_S \leq 50\Omega$						6.0			7.5	mV
Input Offset Voltage Adjustment Range	$T_A = 25^\circ\text{C}, V_S = \pm 20\text{V}$	±10				±15			±15		mV
Input Offset Current	$T_A = 25^\circ\text{C}$		3.0	30		20	200		20	200	nA
	$T_{AMIN} \leq T_A \leq T_{AMAX}$			70		85	500			300	nA
Average Input Offset Current Drift				0.5							$\text{nA}/^\circ\text{C}$
Input Bias Current	$T_A = 25^\circ\text{C}$		30	80		80	500		80	500	nA
	$T_{AMIN} \leq T_A \leq T_{AMAX}$			0.210			1.5			0.8	$\mu\text{A}$
Input Resistance	$T_A = 25^\circ\text{C}, V_S = \pm 20\text{V}$	1.0	6.0		0.3	2.0		0.3	2.0		$\text{M}\Omega$
	$T_{AMIN} \leq T_A \leq T_{AMAX}, V_S = \pm 20\text{V}$	0.5									$\text{M}\Omega$
Input Voltage Range	$T_A = 25^\circ\text{C}$							±12	±13		V
	$T_{AMIN} \leq T_A \leq T_{AMAX}$				±12	±13					V

## Electrical Characteristics (Note 4) (Continued)

Parameter	Conditions	LM741A/LM741E			LM741			LM741C			Units	
		Min	Typ	Max	Min	Typ	Max	Min	Typ	Max		
Large Signal Voltage Gain	$T_A = 25^\circ\text{C}$ , $R_L \geq 2\text{ k}\Omega$ $V_S = \pm 20\text{V}$ , $V_O = \pm 15\text{V}$ $V_S = \pm 15\text{V}$ , $V_O = \pm 10\text{V}$	50			50	200		20	200		V/mV V/mV	
	$T_{AMIN} \leq T_A \leq T_{AMAX}$ , $R_L \geq 2\text{ k}\Omega$ , $V_S = \pm 20\text{V}$ , $V_O = \pm 15\text{V}$ $V_S = \pm 15\text{V}$ , $V_O = \pm 10\text{V}$	32			25			15			V/mV V/mV	
	$V_S = \pm 5\text{V}$ , $V_O = \pm 2\text{V}$	10									V/mV	
Output Voltage Swing	$V_S = \pm 20\text{V}$ $R_L \geq 10\text{ k}\Omega$ $R_L \geq 2\text{ k}\Omega$	$\pm 16$ $\pm 15$									V V	
	$V_S = \pm 15\text{V}$ $R_L \geq 10\text{ k}\Omega$ $R_L \geq 2\text{ k}\Omega$				$\pm 12$ $\pm 10$	$\pm 14$ $\pm 13$		$\pm 12$ $\pm 10$	$\pm 14$ $\pm 13$		V V	
Output Short Circuit Current	$T_A = 25^\circ\text{C}$ $T_{AMIN} \leq T_A \leq T_{AMAX}$	10 10	25	35 40		25			25		mA mA	
Common-Mode Rejection Ratio	$T_{AMIN} \leq T_A \leq T_{AMAX}$ $R_S \leq 10\text{ k}\Omega$ , $V_{CM} = \pm 12\text{V}$ $R_S \leq 50\Omega$ , $V_{CM} = \pm 12\text{V}$	80	95		70	90		70	90		dB dB	
Supply Voltage Rejection Ratio	$T_{AMIN} \leq T_A \leq T_{AMAX}$ , $V_S = \pm 20\text{V}$ to $V_S = \pm 5\text{V}$ $R_S \leq 50\Omega$ $R_S \leq 10\text{ k}\Omega$	86	96		77	96		77	96		dB dB	
Transient Response	$T_A = 25^\circ\text{C}$ , Unity Gain	Rise Time	0.25	0.8		0.3			0.3		$\mu\text{s}$	
		Overshoot	6.0	20		5			5		%	
Bandwidth (Note 5)	$T_A = 25^\circ\text{C}$	0.437	1.5								MHz	
Slew Rate	$T_A = 25^\circ\text{C}$ , Unity Gain	0.3	0.7			0.5			0.5		V/ $\mu\text{s}$	
Supply Current	$T_A = 25^\circ\text{C}$					1.7	2.8		1.7	2.8	mA	
Power Consumption	$T_A = 25^\circ\text{C}$ $V_S = \pm 20\text{V}$ $V_S = \pm 15\text{V}$		80	150							mW mW	
	LM741A $V_S = \pm 20\text{V}$ $T_A = T_{AMIN}$ $T_A = T_{AMAX}$			165 135			50	85		50	85	mW mW
	LM741E $V_S = \pm 20\text{V}$ $T_A = T_{AMIN}$ $T_A = T_{AMAX}$			150 150								mW mW
	LM741 $V_S = \pm 15\text{V}$ $T_A = T_{AMIN}$ $T_A = T_{AMAX}$						60 45	100 75				mW mW

**Note 1:** "Absolute Maximum Ratings" indicate limits beyond which damage to the device may occur. Operating Ratings indicate conditions for which the device is functional, but do not guarantee specific performance limits.

## Electrical Characteristics (Note 4) (Continued)

**Note 2:** For operation at elevated temperatures, these devices must be derated based on thermal resistance, and  $T_j$  max. (listed under "Absolute Maximum Ratings").  $T_j = T_A + (\theta_{JA} P_D)$ .

Thermal Resistance	Cerdip (J)	DIP (N)	HO8 (H)	SO-8 (M)
$\theta_{JA}$ (Junction to Ambient)	100°C/W	100°C/W	170°C/W	195°C/W
$\theta_{JC}$ (Junction to Case)	N/A	N/A	25°C/W	N/A

**Note 3:** For supply voltages less than  $\pm 15V$ , the absolute maximum input voltage is equal to the supply voltage.

**Note 4:** Unless otherwise specified, these specifications apply for  $V_S = \pm 15V$ ,  $-55^\circ C \leq T_A \leq +125^\circ C$  (LM741/LM741A). For the LM741C/LM741E, these specifications are limited to  $0^\circ C \leq T_A \leq +70^\circ C$ .

**Note 5:** Calculated value from:  $BW$  (MHz) =  $0.35/\text{Rise Time}(\mu s)$ .

**Note 6:** For military specifications see RETS741X for LM741 and RETS741AX for LM741A.

**Note 7:** Human body model, 1.5 k $\Omega$  in series with 100 pF.

## Connection Diagram

**Metal Can Package**

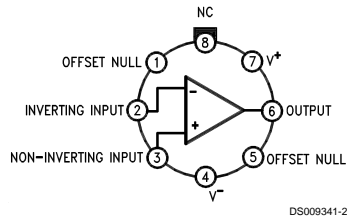

DS009341-2

**Note 8:** LM741H is available per JM38510/10101

**Order Number LM741H, LM741H/883 (Note 8),  
LM741AH/883 or LM741CH**  
See NS Package Number H08C

**Ceramic Dual-In-Line Package**

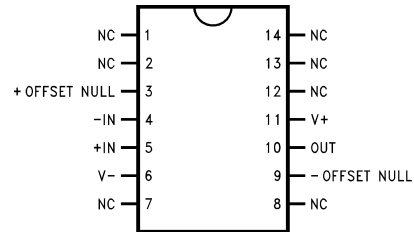

DS009341-6

**Note 9:** also available per JM38510/10101

**Note 10:** also available per JM38510/10102

**Order Number LM741J-14/883 (Note 9),  
LM741AJ-14/883 (Note 10)**  
See NS Package Number J14A

**Dual-In-Line or S.O. Package**

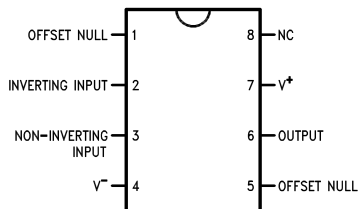

DS009341-3

**Order Number LM741J, LM741J/883,  
LM741CM, LM741CN or LM741EN**  
See NS Package Number J08A, M08A or N08E

**Ceramic Flatpak**

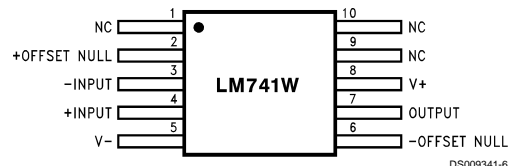

DS009341-6

**Order Number LM741W/883**  
See NS Package Number W10A

**Physical Dimensions** inches (millimeters) unless otherwise noted

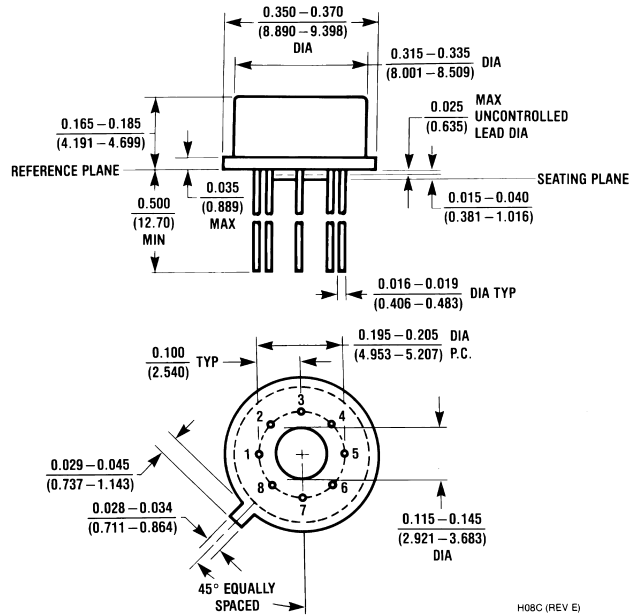

**Metal Can Package (H)**  
 Order Number LM741H, LM741H/883, LM741AH/883, LM741CH or LM741EH  
 NS Package Number HO8C

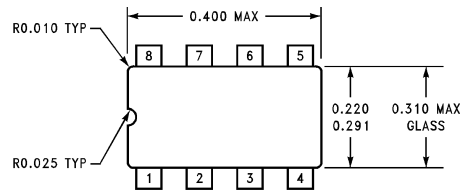

**Ceramic Dual-In-Line Package (J)**  
 Order Number LM741CJ or LM741J/883  
 NS Package Number JO8A

JO8A (REV K)

**Physical Dimensions** inches (millimeters) unless otherwise noted (Continued)

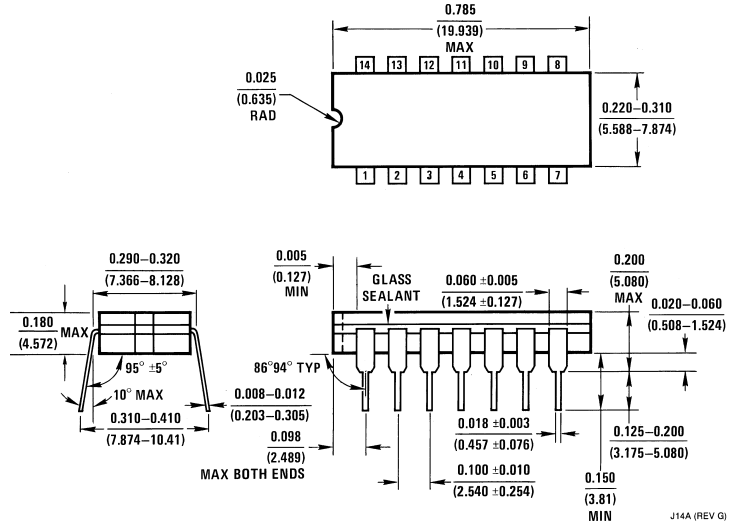

**Ceramic Dual-In-Line Package (J)**  
Order Number LM741J-14/883 or LM741AJ-14/883  
NS Package Number J14A

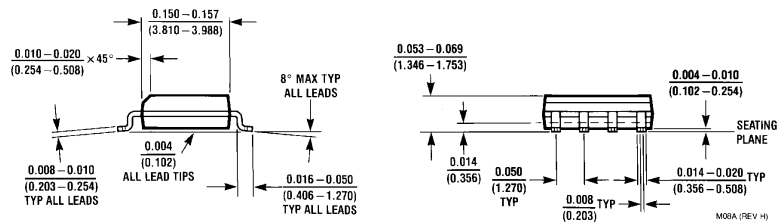
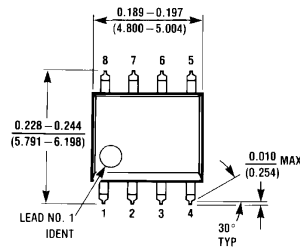

**Small Outline Package (M)**  
Order Number LM741CM  
NS Package Number M08A

**Physical Dimensions** inches (millimeters) unless otherwise noted (Continued)

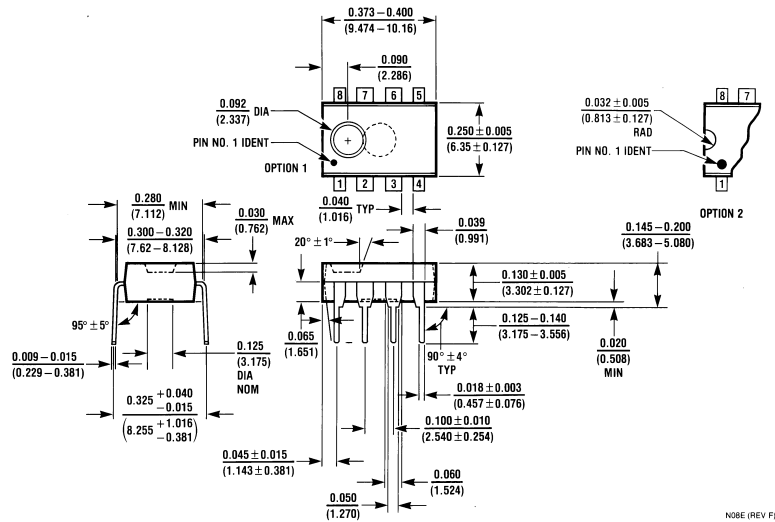

**Dual-In-Line Package (N)**  
**Order Number LM741CN or LM741EN**  
**NS Package Number N08E**

N08E (REV F)

**Physical Dimensions** inches (millimeters) unless otherwise noted (Continued)

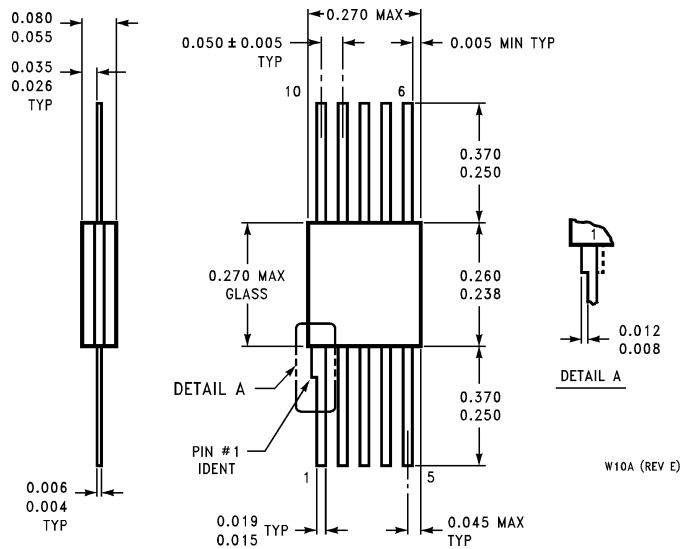

**10-Lead Ceramic Flatpak (W)  
Order Number LM741W/883  
NS Package Number W10A**

**LIFE SUPPORT POLICY**

NATIONAL'S PRODUCTS ARE NOT AUTHORIZED FOR USE AS CRITICAL COMPONENTS IN LIFE SUPPORT DEVICES OR SYSTEMS WITHOUT THE EXPRESS WRITTEN APPROVAL OF THE PRESIDENT OF NATIONAL SEMICONDUCTOR CORPORATION. As used herein:

1. Life support devices or systems are devices or systems which, (a) are intended for surgical implant into the body, or (b) support or sustain life, and whose failure to perform when properly used in accordance with instructions for use provided in the labeling, can be reasonably expected to result in a significant injury to the user.
2. A critical component is any component of a life support device or system whose failure to perform can be reasonably expected to cause the failure of the life support device or system, or to affect its safety or effectiveness.



**National Semiconductor Corporation**  
Americas  
Tel: 1-800-272-9959  
Fax: 1-800-737-7018  
Email: support@nsc.com

www.national.com

**National Semiconductor Europe**

Fax: +49 (0) 1 80-530 85 86  
Email: europe.support@nsc.com  
Deutsch Tel: +49 (0) 1 80-530 85 85  
English Tel: +49 (0) 1 80-532 78 32  
Français Tel: +49 (0) 1 80-532 93 58  
Italiano Tel: +49 (0) 1 80-534 16 80

**National Semiconductor Asia Pacific Customer Response Group**

Tel: 65-2544466  
Fax: 65-2504466  
Email: sea.support@nsc.com

**National Semiconductor Japan Ltd.**

Tel: 81-3-5639-7560  
Fax: 81-3-5639-7507