

LM9071 Low-Dropout System Voltage Regulator with Delayed Reset

General Description

The LM9071 is a 5V, 250 mA low-dropout voltage regulator. The regulator features an active low delayed reset output flag which can be used to reset a microprocessor system on turn-ON and in the event that the regulator output falls out of regulation for any reason. An external capacitor programs a delay time interval before the reset output can return high.

Designed for automotive application the LM9071 contains a variety of protection features such as reverse battery, over-voltage shutdown, thermal shutdown, input transient protection and a wide operating temperature range.

Design techniques have been employed to allow the regulator to remain operational and not generate false reset signals when subjected to high levels of RF energy (300V/m from 2 MHz to 400 MHz).

Features

- Automotive application reliability
- 3% output voltage tolerance
- Insensitive to radiated RFI
- Dropout voltage less than 800 mV with 250 mA output current
- Externally programmed reset delay interval
- Thermal shutdown
- Short circuit protection
- Reverse battery protection
- Wide operating temperature range -40°C to $+125^{\circ}\text{C}$
- TO-220 and TO-263 power surface mount power packages
- Pin for pin compatible with the LM2927, L4947 and TLE4260

Typical Application and Connection Diagrams (Top View)

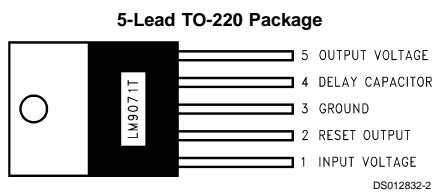
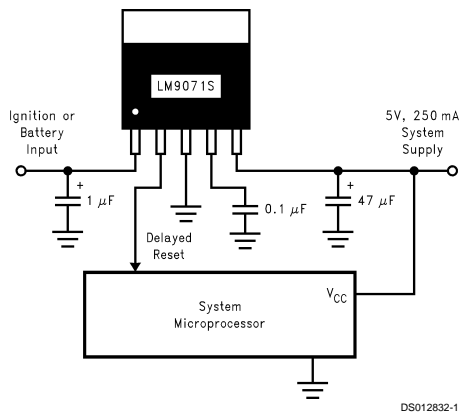

Order Number **LM9071T**
See NS Package Number **T05A**

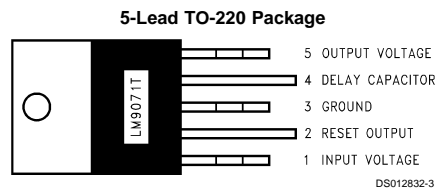

Order Number **LM9071T/Flow LB03**
See NS Package Number **T05D**

5-Lead TO-263 Surface Mount Package

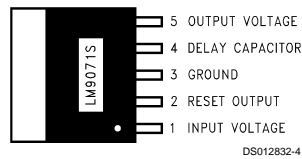

Tab and Backside metal on all packages internally connected to ground.

Order Number **LM9071S**
See NS Package Number **TS5B**

Absolute Maximum Ratings (Note 1)

DC Input Voltage	-26V to +26V
Positive Input Transient (t<100 ms)	60V
Negative Input Transient (t<1 ms)	-50V
Reset Output Sink Current	5 mA
Power Dissipation	Internally Limited
Junction Temperature	150°C
ESD Susceptibility (Note 2)	12 kV, 2 kV
Lead Temperature (Soldering, 10 seconds)	260°C

Storage Temperature

-50°C to +150°C

Operating Ratings (Note 1)

Input Voltage	6V to 26V
Ambient Temperature	-40°C to +125°C
θ _{JC} , TO-220, TO-263 Packages	3°C/W
θ _{JA} , TO-220, TO-263 Packages	43°C/W

Electrical Characteristics

The following specifications apply for $V_{CC} = 6V$ to $26V$, $-40^\circ C \leq T_A \leq +125^\circ C$, unless otherwise specified. $C_{OUT} = 47 \mu Fd$ with an $ESR < 3\Omega$. $C_{IN} = 1 \mu Fd$.

Symbol	Parameter	Conditions	Min	Max	Units
REGULATOR OUTPUT					
V_{OUT}	Output Voltage	$5 \text{ mA} \leq I_{OUT} \leq 250 \text{ mA}$	4.85	5.15	V
ΔV_{OUT} Line	Line Regulation	$I_{OUT} = 5 \text{ mA}$, $9V \leq V_{IN} \leq 16.5V$ $I_{OUT} = 250 \text{ mA}$		25 50	mV mV
ΔV_{OUT} Load	Load Regulation	$V_{IN} = 14.4V$, $5 \text{ mA} \leq I_{OUT} \leq 250 \text{ mA}$		60	mV
I_q	Quiescent Current	$I_{OUT} = 5 \text{ mA}$ $I_{OUT} = 250 \text{ mA}$, $V_{IN} \geq 8V$ $I_{OUT} = 5 \text{ mA}$, $V_{IN} = 5V$ $I_{OUT} = 250 \text{ mA}$, $V_{IN} = 6V$		4 25 10 50	mA mA mA mA
V_{do}	Dropout Voltage	$I_{OUT} = 5 \text{ mA}$ $I_{OUT} = 250 \text{ mA}$		300 800	mV mV
I_{sc}	Short Circuit Current	$R_L = 1\Omega$	0.35	1.5	A
RR	Ripple Rejection	$F_{ripple} = 120 \text{ Hz}$, $V_{ripple} = 1 \text{ Vrms}$ $I_{OUT} = 50 \text{ mA}$	60		dB
OVthr	Overvoltage Shutdown Threshold		27		V
V_O Transient	V_{OUT} during Transients	$V_{IN \text{ Peak}} \leq 60V$, $R_L = 100\Omega$, $\tau = 100 \text{ ms}$		7	V
RESET OUTPUT					
V_{th}	Threshold Voltage	ΔV_{OUT} Required to Generate a Reset Output $4.8V \leq V_{OUT} \leq 5.2V$	-300	-500	mV
V_{low}	Reset Output Low Voltage	$I_{sink} = 1.6 \text{ mA}$, $V_{OUT} > 3.2V$ $1.4V \leq V_{OUT} \leq 3.2V$		0.4 0.8	V V
V_{high}	Reset Output High Voltage		0.8 V_{OUT}		V
t_{delay}	Delay Time	$C_{delay} = 100 \text{ mFd}$	7.6	35	ms
I_{delay}	Charging Current for C_{delay}		10	30	μA
R_{pu}	Internal Pull-up Resistance		12	80	k Ω

Note 1: Absolute Maximum Ratings indicate limits beyond which damage to the device may occur. **Operating Ratings** indicate conditions for which the device is intended to be functional, but do not guarantee specific performance limits. For guaranteed specifications and conditions, see the **Electrical Characteristics**.

Note 2: All pins will survive an ESD impulse of $\pm 2000V$ using the human body model of 100 pF discharged through a $1.5 \text{ k}\Omega$ resistor. In addition the input voltage pin will withstand ten pulses of $\pm 12 \text{ kV}$ from a 150 pF capacitor discharged through a 560Ω resistor when bypassed with a 22 nF , $100V$ capacitor.

Typical Performance Characteristics ($T_A = 25^\circ\text{C}$ unless indicated otherwise)

Turn ON Characteristics

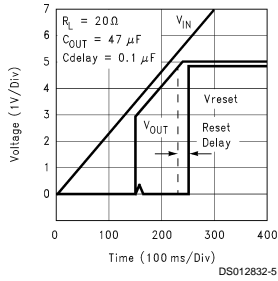

Turn OFF Characteristics

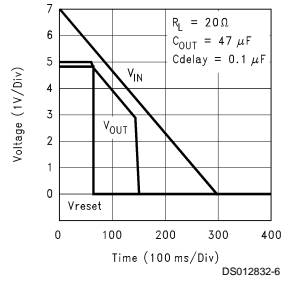

Normalized Output Voltage vs Temperature

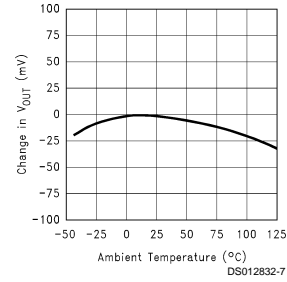

Output Voltage at Input Voltage Extremes

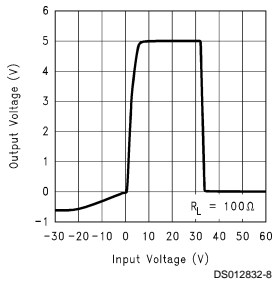

Quiescent Current vs Input Voltage

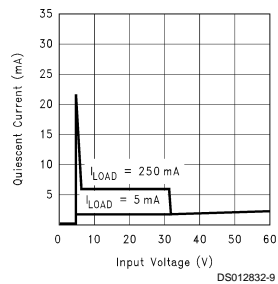

Short Circuit Current vs Temperature

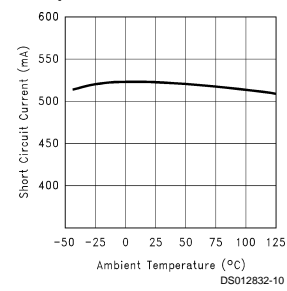

Dropout Voltage vs Temperature

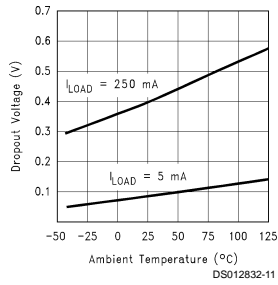

Reset Delay Time vs Temperature

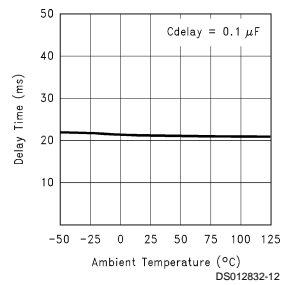

Output Capacitor ESR

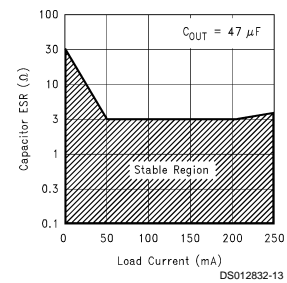

Typical Performance Characteristics ($T_A = 25^\circ\text{C}$ unless indicated otherwise) (Continued)

Maximum Power Dissipation (TO-220 Package)

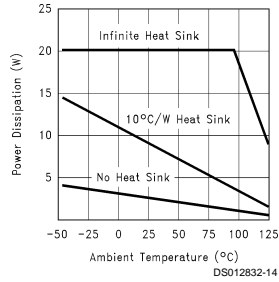

Maximum Power Dissipation (TO-263 Package)

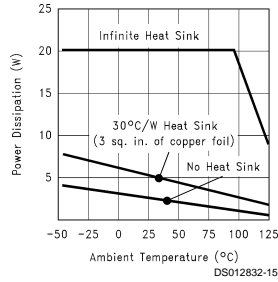

Reset Operation and Protection Features

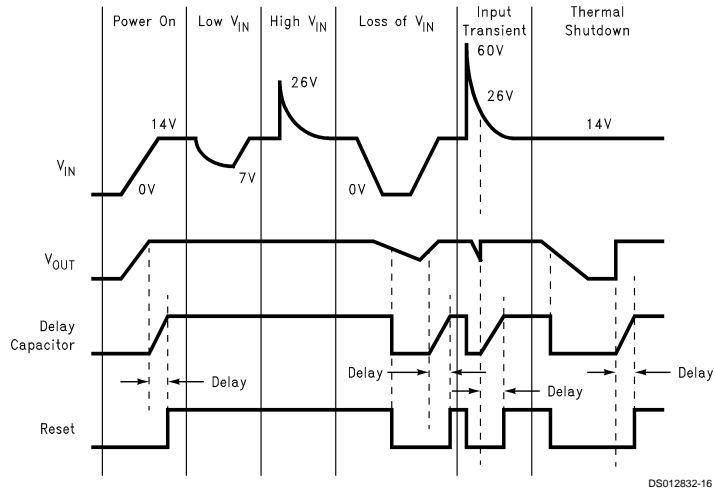

Block Diagram

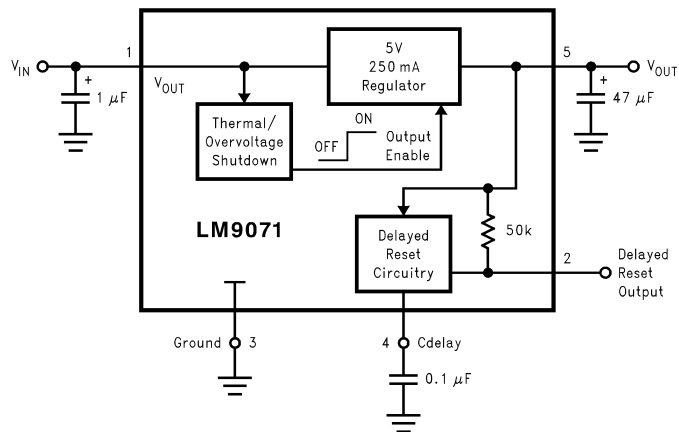

Application Hints

The LM9071 voltage regulator has been optimized for use in microprocessor based automotive systems. Several unique design features have been incorporated to address many FMEA (Failure Mode Effects Analysis) concerns for fail-safe system performance.

FAULT TOLERANT FEATURES

While not specifically guaranteed due to production testing limitations, the LM9071 has been tested and shown to continue to provide a regulated output and, not generate an erroneous system reset signal while subjected to high levels of RF electric field energy (up to 300 V/m signal strength over a 2 MHz to 400 MHz frequency range). This is very important in vehicle safety related applications where the system must continue to operate normally. To maintain this immunity to RFI the output bypass capacitor is important (47 μ F is recommended).

An output bypass capacitor of at least 10 μ F is required for stability (47 μ F is recommended). The ESR of this capacitor should be less than 3 Ω . An input capacitor of 1 μ F or larger is recommended to improve line transient and noise performance.

Conventional load dump protection is built in to withstand up to +60V and -50V transients. Protection against reverse polarity battery connections is also built in. With a reversed battery connection the output of the LM9071 will not go more negative than one diode drop below ground. This will prevent damage to any of the 5V load circuits.

RESET FLAG

Excessive loading of the output to the point where the output voltage drops by 300 mV to 500 mV will signal a reset flag to the micro. This will warn of a V_{CC} supply that may produce unpredictable operation of the system. On power-up and re-

covery from a fault condition the delay capacitor is used to hold the micro in a reset condition for a programmable time interval to allow the system operating voltages and clock to stabilize before executing code. The delay time interval can be estimated by the following equation:

$$t_{\text{delay}} = \frac{3.8V \times C_{\text{delay}}}{20 \mu A}$$

INPUT STABILITY

Low dropout voltage regulators which utilize a PNP power transistor usually exhibit a large increase in current when in dropout ($V_{IN} < 5.5V$). This increase is caused by the saturation characteristics (β reduction) of the PNP transistor. To significantly minimize this increase in current the LM9071 detects when the PNP enters saturation and reduces the operating current.

This reduction in input current can create a stability problem in applications with higher load current (> 100 mA) where the input voltage is applied through a long length of wire, which in effect adds a significant amount of inductance in series with the input. The drop in input current may create a positive input voltage transient which may take the PNP out of saturation. If the input voltage is held constant at the threshold where the PNP is going in and out of saturation, an oscillation may be created.

This is only observed where a large series inductance is present in the input supply line and when the rise and fall time of the input supply is very slow. If the application and removal of the input voltage changes at a rate greater than 500 mV/ μ s it will move through the dropout region of the regulator (V_{IN} of 3V to 5.5V) too quickly for an oscillation to be established.

Physical Dimensions inches (millimeters) unless otherwise noted

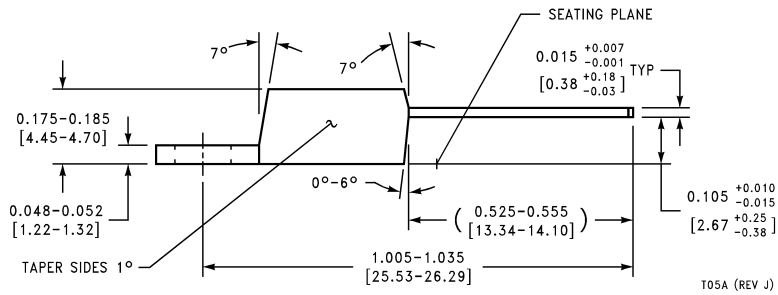
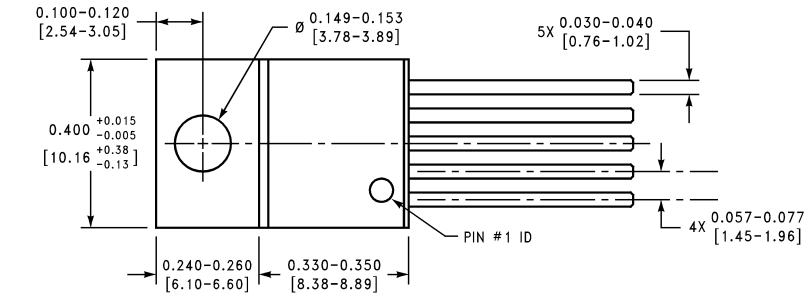

5-Lead Molded TO-220
Order Number LM9071T
NS Package Number T05A

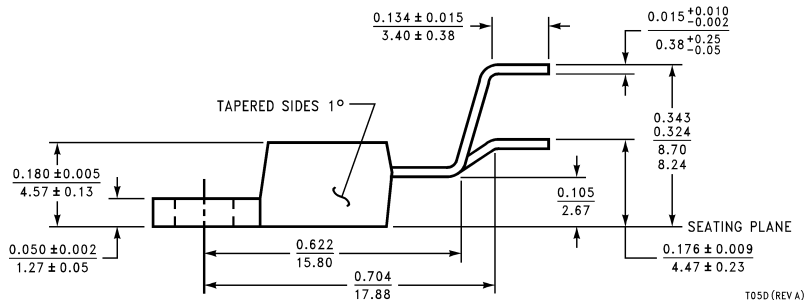
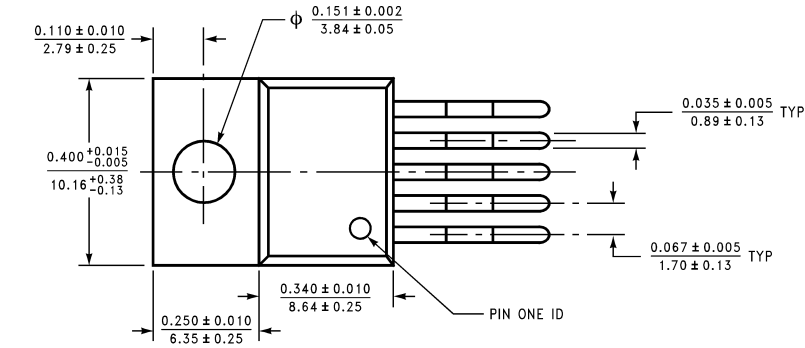

5-Lead Molded TO-220
Order Number LM9071T/Flow LB03
NS Package Number T05D

Physical Dimensions inches (millimeters) unless otherwise noted (Continued)

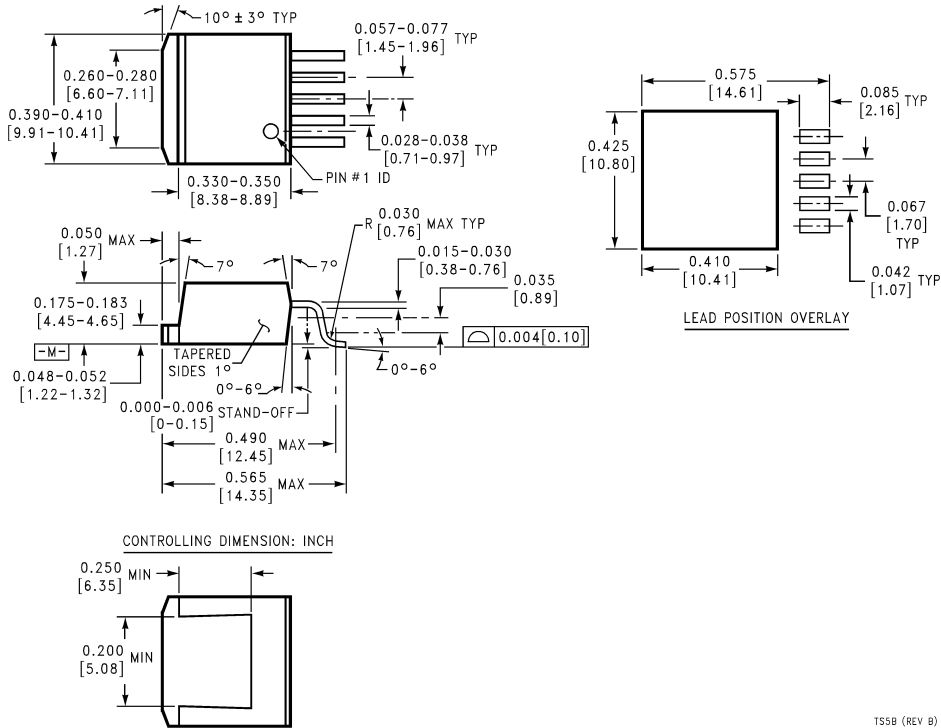

**5-Lead Molded TO-263
Order Number LM9071S
NS Package Number TS5B**

TS5B (REV B)

LIFE SUPPORT POLICY

NATIONAL'S PRODUCTS ARE NOT AUTHORIZED FOR USE AS CRITICAL COMPONENTS IN LIFE SUPPORT DEVICES OR SYSTEMS WITHOUT THE EXPRESS WRITTEN APPROVAL OF THE PRESIDENT AND GENERAL COUNSEL OF NATIONAL SEMICONDUCTOR CORPORATION. As used herein:

1. Life support devices or systems are devices or systems which, (a) are intended for surgical implant into the body, or (b) support or sustain life, and whose failure to perform when properly used in accordance with instructions for use provided in the labeling, can be reasonably expected to result in a significant injury to the user.
2. A critical component is any component of a life support device or system whose failure to perform can be reasonably expected to cause the failure of the life support device or system, or to affect its safety or effectiveness.

National Semiconductor Corporation
Americas
Tel: 1-800-272-9959
Fax: 1-800-737-7018
Email: support@nsc.com

National Semiconductor Europe
Fax: +49 (0) 1 80-530 85 86
Email: europe.support@nsc.com
Deutsch Tel: +49 (0) 1 80-530 85 85
English Tel: +49 (0) 1 80-532 78 32
Français Tel: +49 (0) 1 80-532 93 58
Italiano Tel: +49 (0) 1 80-534 16 80

National Semiconductor Asia Pacific Customer Response Group
Tel: 65-2544466
Fax: 65-2504466
Email: sea.support@nsc.com

National Semiconductor Japan Ltd.
Tel: 81-3-5639-7560
Fax: 81-3-5639-7507

www.national.com