

LP2952/LP2952A/LP2953/LP2953A Adjustable Micropower Low-Dropout Voltage Regulators

General Description

The LP2952 and LP2953 are micropower voltage regulators with very low quiescent current (130 μ A typical at 1 mA load) and very low dropout voltage (typ. 60 mV at light load and 470 mV at 250 mA load current). They are ideally suited for battery-powered systems. Furthermore, the quiescent current increases only slightly at dropout, which prolongs battery life.

The LP2952 and LP2953 retain all the desirable characteristics of the LP2951, but offer increased output current, additional features, and an improved shutdown function.

The internal crowbar pulls the output down quickly when the shutdown is activated.

The error flag goes low if the output voltage drops out of regulation.

Reverse battery protection is provided.

The internal voltage reference is made available for external use, providing a low-T.C. reference with very good line and load regulation.

The parts are available in DIP and surface mount packages.

Features

- Output voltage adjusts from 1.23V to 29V
- Guaranteed 250 mA output current
- Extremely low quiescent current
- Low dropout voltage
- Extremely tight line and load regulation
- Very low temperature coefficient
- Current and thermal limiting
- Reverse battery protection
- 50 mA (typical) output pull-down crowbar
- 5V and 3.3V versions available

LP2953 Versions Only

- Auxiliary comparator included with CMOS/TTL compatible output levels. Can be used for fault detection, low input line detection, etc.

Applications

- High-efficiency linear regulator
- Regulator with under-voltage shutdown
- Low dropout battery-powered regulator
- Snap-ON/Snap-OFF regulator

Block Diagrams

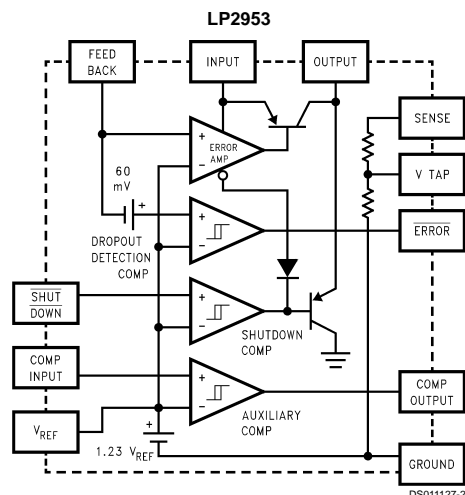
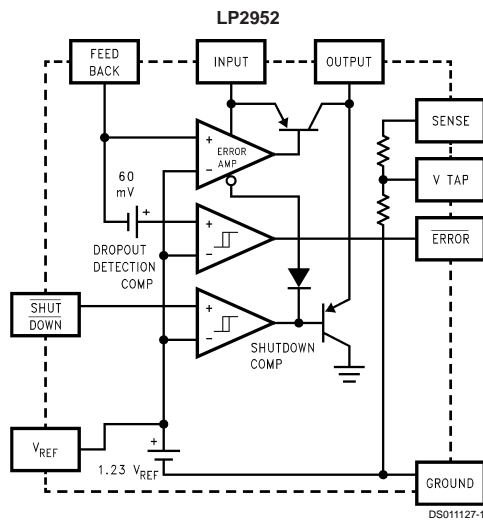

Pinout Drawings

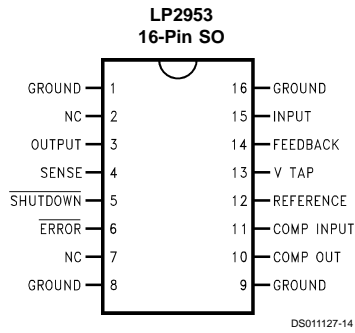
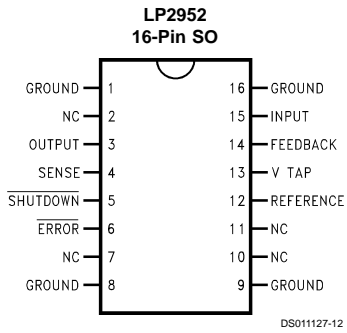
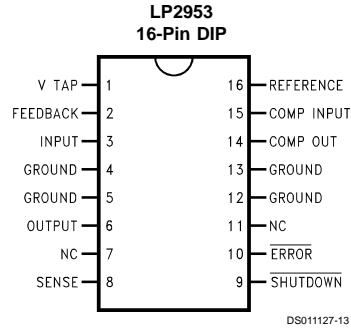
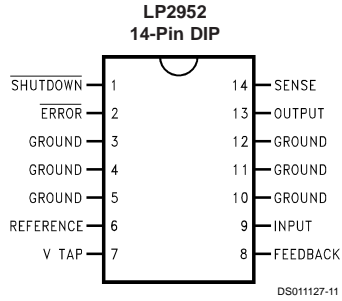

Ordering Information

LP2952

Order Number	Temp. Range (T _j) °C	Package	NSC Drawing Number
LP2952IN, LP2952AIN, LP2952IN-3.3, LP2952AIN-3.3	-40 to +125	14-Pin Molded DIP	N14A
LP2952IM, LP2952AIM, LP2952IM-3.3, LP2952AIM-3.3	-40 to +125	16-Pin Surface Mount	M16A

LP2953

Order Number	Temp. Range (T _j) °C	Package	NSC Drawing Number
LP2953IN, LP2953AIN, LP2953IN-3.3, LP2953AIN-3.3	-40 to +125	16-Pin Molded DIP	N16A
LP2953IM, LP2953AIM, LP2953IM-3.3, LP2953AIM-3.3	-40 to +125	16-Pin Surface Mount	M16A
LP2953AMJ/883 5962-9233601MEA LP2953AMJ-QMLV 5962-9233601VEA	-55 to +150	16-Pin Ceramic DIP	J16A
LP2953AMWG/883 5962-9233601QXA LP2953AMWG-QMLV 5962-9233601VXA	-55 to +150	16-Pin Ceramic Surface Mount	WG16A

Absolute Maximum Ratings (Note 1)

If Military/Aerospace specified devices are required, please contact the National Semiconductor Sales Office/ Distributors for availability and specifications.

Storage Temperature Range	$-65^{\circ}\text{C} \leq T_A \leq +150^{\circ}\text{C}$
Operating Temperature Range	
LP2952I, LP2953I, LP2952AI, LP2953AI, LP2952I-3.3, LP2953I-3.3, LP2952AI-3.3, LP2953AI-3.3	$-40^{\circ}\text{C} \leq T_J \leq +125^{\circ}\text{C}$
LP2953AM	$-55^{\circ}\text{C} \leq T_A \leq +125^{\circ}\text{C}$
Lead Temp. (Soldering, 5 seconds)	260°C
Power Dissipation (Note 2)	Internally Limited

Maximum Junction Temperature
 LP2952I, LP2953I, LP2952AI, LP2953AI, LP2952I-3.3, LP2953I-3.3, LP2952AI-3.3, LP2953AI-3.3

LP2953AM	+125°C
LP2953AM	+150°C
Input Supply Voltage	-20V to +30V
Feedback Input Voltage (Note 3)	-0.3V to +5V
Comparator Input Voltage (Note 4)	-0.3V to +30V
Shutdown Input Voltage (Note 4)	-0.3V to +30V
Comparator Output Voltage (Note 4)	-0.3V to +30V
ESD Rating (Note 15)	2 kV

Electrical Characteristics Limits in standard typeface are for $T_J = 25^{\circ}\text{C}$, **bold typeface** applies over the full operating temperature range. Limits are guaranteed by production testing or correlation techniques using standard Statistical Quality Control (SQC) methods. Unless otherwise specified: $V_{IN} = V_O(\text{NOM}) + 1\text{V}$, $I_L = 1\text{mA}$, $C_L = 2.2\ \mu\text{F}$ for 5V parts and $4.7\ \mu\text{F}$ for 3.3V parts. Feedback pin is tied to V Tap pin, Output pin is tied to Output Sense pin.

3.3V Versions

Symbol	Parameter	Conditions	Typical	LP2952AI-3.3, LP2953AI-3.3		LP2952I-3.3, LP2953I-3.3		Units
				Min	Max	Min	Max	
V_O	Output Voltage		3.3	3.284	3.317	3.267	3.333	V
		$1\text{mA} \leq I_L \leq 250\text{mA}$	3.3	3.260	3.340	3.234	3.366	
				3.254	3.346	3.221	3.379	

5V Versions

Symbol	Parameter	Conditions	Typical	LP2952AI, LP2953AI, LP2953AM (Note 17)		LP2952I, LP2953I		Units
				Min	Max	Min	Max	
V_O	Output Voltage		5.0	4.975	5.025	4.950	5.050	V
		$1\text{mA} \leq I_L \leq 250\text{mA}$	5.0	4.940	5.060	4.900	5.100	
				4.930	5.070	4.880	5.120	

All Voltage Options

Electrical Characteristics

Limits in standard typeface are for $T_J = 25^{\circ}\text{C}$, **bold typeface** applies over the full operating temperature range. Limits are guaranteed by production testing or correlation techniques using standard Statistical Quality Control (SQC) methods. Unless otherwise specified: $V_{IN} = V_O(\text{NOM}) + 1\text{V}$, $I_L = 1\text{mA}$, $C_L = 2.2\ \mu\text{F}$ for 5V parts and $4.7\ \mu\text{F}$ for 3.3V parts. Feedback pin is tied to V Tap pin, Output pin is tied to Output Sense pin.

Symbol	Parameter	Conditions	Typical	LP2952AI, LP2953AI, LP2952AI-3.3, LP2953AI-3.3, LP2953AM (Notes 16, 17)		LP2952I, LP2953I, LP2952I-3.3, LP2953I-3.3		Units
				Min	Max	Min	Max	

REGULATOR

$\frac{\Delta V_O}{\Delta T}$	Output Voltage Temp. Coefficient	(Note 5)	20		100		150	ppm/°C
$\frac{\Delta V_O}{V_O}$	Output Voltage Line Regulation	$V_{IN} = V_O(\text{NOM}) + 1\text{V}$ to 30V	0.03		0.1		0.2	%
$\frac{\Delta V_O}{V_O}$	Output Voltage Load Regulation (Note 6)	$I_L = 1\text{mA}$ to 250 mA $I_L = 0.1\text{mA}$ to 1 mA	0.04		0.16		0.20	%
					0.20		0.30	

Electrical Characteristics (Continued)

Limits in standard typeface are for $T_J = 25^\circ\text{C}$. **bold typeface** applies over the full operating temperature range. Limits are guaranteed by production testing or correlation techniques using standard Statistical Quality Control (SQC) methods. Unless otherwise specified: $V_{IN} = V_O(\text{NOM}) + 1\text{V}$, $I_L = 1\text{ mA}$, $C_L = 2.2\ \mu\text{F}$ for 5V parts and $4.7\ \mu\text{F}$ for 3.3V parts. Feedback pin is tied to V Tap pin, Output pin is tied to Output Sense pin.

Symbol	Parameter	Conditions	Typical	LP2952AI, LP2953AI, LP2952AI-3.3, LP2953AI-3.3, LP2953AM (Notes 16, 17)		LP2952I, LP2953I, LP2952I-3.3, LP2953I-3.3		Units
				Min	Max	Min	Max	
REGULATOR								
$V_{IN}-V_O$	Dropout Voltage (Note 7)	$I_L = 1\text{ mA}$	60		100 150		100 150	mV
		$I_L = 50\text{ mA}$	240		300 420		300 420	
		$I_L = 100\text{ mA}$	310		400 520		400 520	
		$I_L = 250\text{ mA}$	470		600 800		600 800	
I_{GND}	Ground Pin Current (Note 8)	$I_L = 1\text{ mA}$	130		170 200		170 200	μA
		$I_L = 50\text{ mA}$	1.1		2 2.5		2 2.5	mA
		$I_L = 100\text{ mA}$	4.5		6 8		6 8	
		$I_L = 250\text{ mA}$	21		28 33		28 33	
I_{GND}	Ground Pin Current at Dropout	$V_{IN} = V_O(\text{NOM}) - 0.5\text{V}$ $I_L = 100\ \mu\text{A}$	165		210 240		210 240	μA
I_{GND}	Ground Pin Current at Shutdown (Note 8)	$V_{\text{SHUTDOWN}} \leq 1.1\text{V}$	105		140		140	μA
I_{LIMIT}	Current Limit	$V_{\text{OUT}} = 0$	380		500 530		500 530	mA
$\frac{\Delta V_O}{\Delta P_d}$	Thermal Regulation	(Note 10)	0.05		0.2		0.2	%/W
e_n	Output Noise Voltage (10 Hz to 100 kHz) $I_L = 100\text{ mA}$	$C_L = 4.7\ \mu\text{F}$	400					μV RMS
		$C_L = 33\ \mu\text{F}$	260					
		$C_L = 33\ \mu\text{F}$ (Note 11)	80					
V_{REF}	Reference Voltage	(Note 12)	1.230	1.215 1.205	1.245 1.255	1.205 1.190	1.255 1.270	V
$\frac{\Delta V_{\text{REF}}}{V_{\text{REF}}}$	Reference Voltage Line Regulation	$V_{IN} = 2.5\text{V to } V_O(\text{NOM}) + 1\text{V}$ $V_{IN} = V_O(\text{NOM}) + 1\text{V to } 30\text{V}$ (Note 13)	0.03		0.1 0.2		0.2 0.4	%
$\frac{\Delta V_{\text{REF}}}{V_{\text{REF}}}$	Reference Voltage Load Regulation	$I_{\text{REF}} = 0\text{ to } 200\ \mu\text{A}$	0.25		0.4 0.6		0.8 1.0	%
$\frac{\Delta V_{\text{REF}}}{\Delta T}$	Reference Voltage Temp. Coefficient	(Note 5)	20					ppm/ $^\circ\text{C}$
$I_{\text{B}}(\text{FB})$	Feedback Pin Bias Current		20		40 60		40 60	nA
$I_{\text{O}}(\text{SINK})$	Output "OFF" Pulldown Current	(Note 9)		30 20		30 20		mA

Electrical Characteristics (Continued)

Limits in standard typeface are for $T_J = 25^\circ\text{C}$, **bold typeface** applies over the full operating temperature range. Limits are guaranteed by production testing or correlation techniques using standard Statistical Quality Control (SQC) methods. Unless otherwise specified: $V_{IN} = V_O(\text{NOM}) + 1\text{V}$, $I_L = 1\text{ mA}$, $C_L = 2.2\ \mu\text{F}$ for 5V parts and $4.7\ \mu\text{F}$ for 3.3V parts. Feedback pin is tied to V Tap pin, Output pin is tied to Output Sense pin.

Symbol	Parameter	Conditions	Typical	LP2952AI, LP2953AI, LP2952AI-3.3, LP2953AI-3.3, LP2953AM (Notes 16, 17)		LP2952I, LP2953I, LP2952I-3.3, LP2953I-3.3		Units
				Min	Max	Min	Max	
DROPOUT DETECTION COMPARATOR								
I_{OH}	Output "HIGH" Leakage	$V_{OH} = 30\text{V}$	0.01		1 2		1 2	μA
V_{OL}	Output "LOW" Voltage	$V_{IN} = V_O(\text{NOM}) - 0.5\text{V}$ $I_O(\text{COMP}) = 400\ \mu\text{A}$	150		250 400		250 400	mV
$V_{THR}(\text{MAX})$	Upper Threshold Voltage	(Note 14)	-60	-80 -95	-35 -25	-80 -95	-35 -25	mV
$V_{THR}(\text{MIN})$	Lower Threshold Voltage	(Note 14)	-85	-110 -160	-55 -40	-110 -160	-55 -40	mV
HYST	Hysteresis	(Note 14)	15					mV
SHUTDOWN INPUT (Note 15)								
V_{OS}	Input Offset Voltage	(Referred to V_{REF})	± 3	-7.5 -10	7.5 10	-7.5 -10	7.5 10	mV
HYST	Hysteresis		6					mV
I_B	Input Bias Current	$V_{IN}(\text{S/D}) = 0\text{V to } 5\text{V}$	10	-30 -50	30 50	-30 -50	-30 50	nA
			LP2953AM	10	-30 -75	30 75		
AUXILIARY COMPARATOR (LP2953 Only)								
V_{OS}	Input Offset Voltage	(Referred to V_{REF})	± 3	-7.5 -10	7.5 10	-7.5 -10	7.5 10	mV
			LP2953AM	± 3	-7.5 -12	7.5 12		
HYST	Hysteresis		6					mV
I_B	Input Bias Current	$V_{IN}(\text{COMP}) = 0\text{V to } 5\text{V}$	10	-30 -50	30 50	-30 -50	30 50	nA
			LP2953AM	10	-30 -75	30 75		
I_{OH}	Output "HIGH" Leakage	$V_{OH} = 30\text{V}$ $V_{IN}(\text{COMP}) = 1.3\text{V}$	0.01		1 2		1 2	μA
			LP2953AM	0.01		1 2.2		
V_{OL}	Output "LOW" Voltage	$V_{IN}(\text{COMP}) = 1.1\text{V}$ $I_O(\text{COMP}) = 400\ \mu\text{A}$	150		250 400		250 400	mV
			LP2953AM	150		250 420		

Note 1: Absolute maximum ratings indicate limits beyond which damage to the component may occur. Electrical specifications do not apply when operating the device outside of its rated operating conditions.

Note 2: The maximum allowable power dissipation is a function of the maximum junction temperature, $T_J(\text{MAX})$, the junction-to-ambient thermal resistance, θ_{J-A} , and the ambient temperature, T_A . The maximum allowable power dissipation at any ambient temperature is calculated using the equation for $P(\text{MAX})$,

$$P(\text{MAX}) = \frac{T_J(\text{MAX}) - T_A}{\theta_{J-A}}$$

Electrical Characteristics (Continued)

Exceeding the maximum allowable power dissipation will cause excessive die temperature, and the regulator will go into thermal shutdown. See APPLICATION HINTS for additional information on heatsinking and thermal resistance.

Note 3: When used in dual-supply systems where the regulator load is returned to a negative supply, the output voltage must be diode-clamped to ground.

Note 4: May exceed the input supply voltage.

Note 5: Output or reference voltage temperature coefficient is defined as the worst case voltage change divided by the total temperature range.

Note 6: Load regulation is measured at constant junction temperature using low duty cycle pulse testing. Two separate tests are performed, one for the range of 100 μ A to 1 mA and one for the 1 mA to 250 mA range. Changes in output voltage due to heating effects are covered by the thermal regulation specification.

Note 7: Dropout voltage is defined as the input to output differential at which the output voltage drops 100 mV below the value measured with a 1V differential. At very low values of programmed output voltage, the input voltage minimum of 2V (2.3V over temperature) must be observed.

Note 8: Ground pin current is the regulator quiescent current. The total current drawn from the source is the sum of the ground pin current, output load current, and current through the external resistive divider (if used).

Note 9: $V_{SHUTDOWN} \leq 1.1V$, $V_{OUT} = V_O(NOM)$.

Note 10: Thermal regulation is the change in output voltage at a time T after a change in power dissipation, excluding load or line regulation effects. Specifications are for a 200 mA load pulse at $V_{IN} = V_O(NOM)+15V$ (3W pulse) for T = 10 ms.

Note 11: Connect a 0.1 μ F capacitor from the output to the feedback pin.

Note 12: $V_{REF} \leq V_{OUT} \leq (V_{IN} - 1V)$, $2.3V \leq V_{IN} \leq 30V$, $100 \mu A \leq I_L \leq 250 mA$.

Note 13: Two separate tests are performed, one covering $2.5V \leq V_{IN} \leq V_O(NOM)+1V$ and the other test for $V_O(NOM)+1V \leq V_{IN} \leq 30V$.

Note 14: Comparator thresholds are expressed in terms of a voltage differential at the Feedback terminal below the nominal reference voltage measured at $V_{IN} = V_O(NOM) + 1V$. To express these thresholds in terms of output voltage change, multiply by the Error Amplifier gain, which is $V_{OUT}/V_{REF} = (R1 + R2)/R2$ (refer to Figure 4).

Note 15: Human body model, 200 pF discharged through 1.5 k Ω .

Note 16: Drive $\overline{Shutdown}$ pin with TTL or CMOS-low level to shut regulator OFF, high level to turn regulator ON.

Note 17: A military RETS specification is available upon request. For more information on military products, please refer to the Mil-Aero web page at <http://www.national.com/appinfo/milaero/index.html>.

Typical Performance Characteristics Unless otherwise specified: $V_{IN} = 6V$, $I_L = 1 mA$, $C_L = 2.2 \mu F$, $V_{SD} = 3V$, $T_A = 25^\circ C$, $V_{OUT} = 5V$.

Quiescent Current

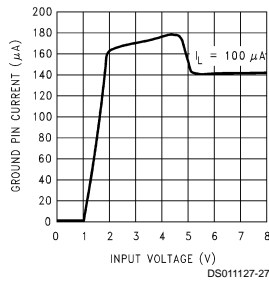

Quiescent Current

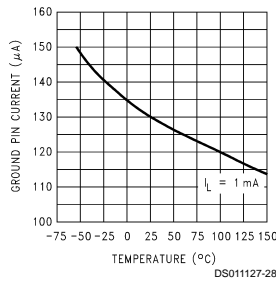

Ground Pin Current vs Load

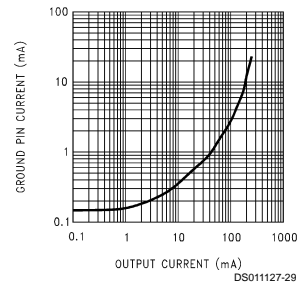

Ground Pin Current

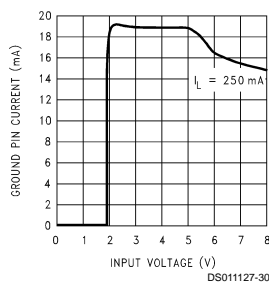

Ground Pin Current

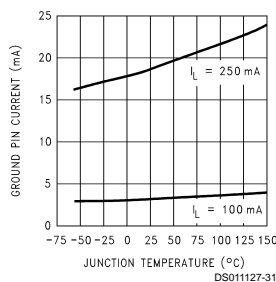

Output Noise Voltage

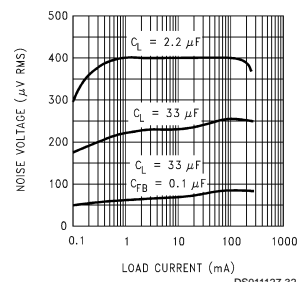

Typical Performance Characteristics Unless otherwise specified: $V_{IN} = 6V$, $I_L = 1\text{ mA}$, $C_L = 2.2\ \mu\text{F}$, $V_{SD} = 3V$, $T_A = 25^\circ\text{C}$, $V_{OUT} = 5V$. (Continued)

Ripple Rejection

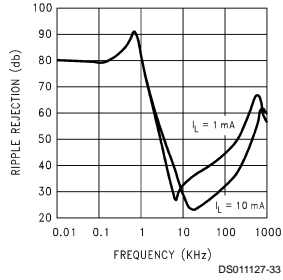

DS011127-33

Ripple Rejection

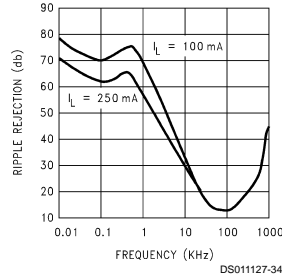

DS011127-34

Ripple Rejection

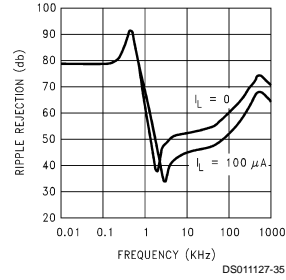

DS011127-35

Line Transient Response

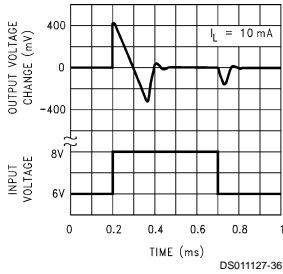

DS011127-36

Line Transient Response

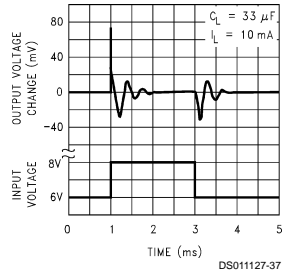

DS011127-37

Output Impedance

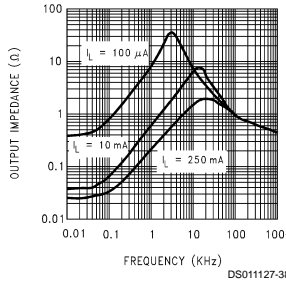

DS011127-38

Load Transient Response

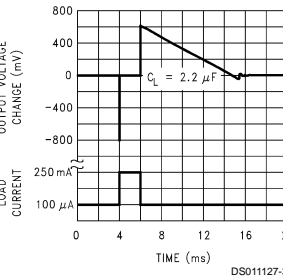

DS011127-39

Load Transient Response

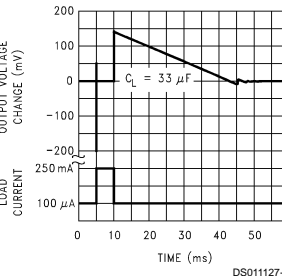

DS011127-40

Dropout Characteristics

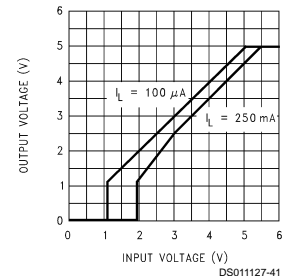

DS011127-41

Enable Transient

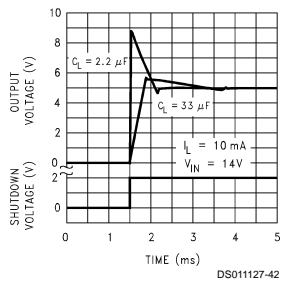

DS011127-42

Enable Transient

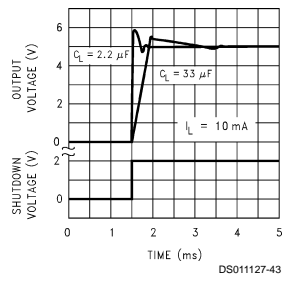

DS011127-43

Short-Circuit Output Current and Maximum Output Current

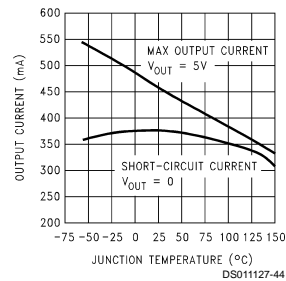

DS011127-44

Typical Performance Characteristics Unless otherwise specified: $V_{IN} = 6V$, $I_L = 1\text{ mA}$, $C_L = 2.2\text{ }\mu\text{F}$, $V_{SD} = 3V$, $T_A = 25^\circ\text{C}$, $V_{OUT} = 5V$. (Continued)

Feedback Bias Current

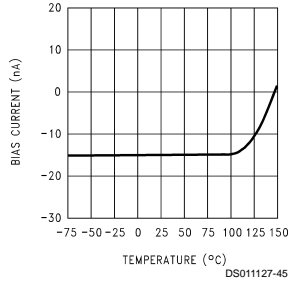

Feedback Pin Current

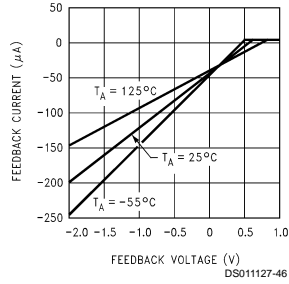

Error Output

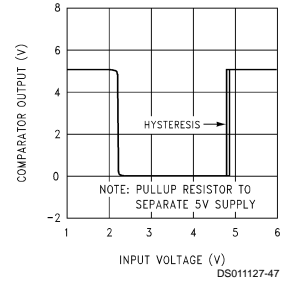

Comparator Sink Current

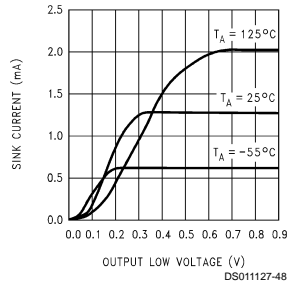

Divider Resistance

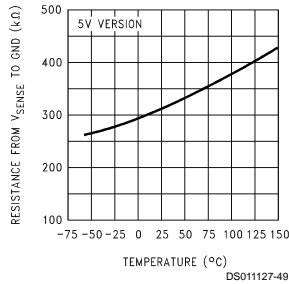

Dropout Detection Comparator Threshold Voltages

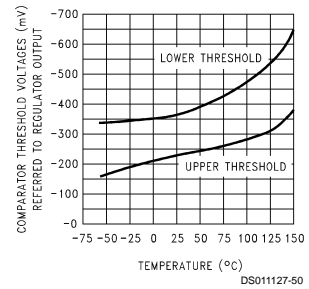

Thermal Regulation

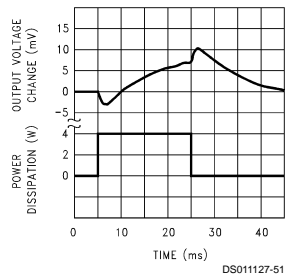

Minimum Operating Voltage

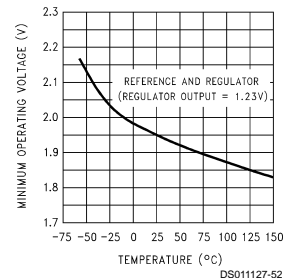

Dropout Voltage

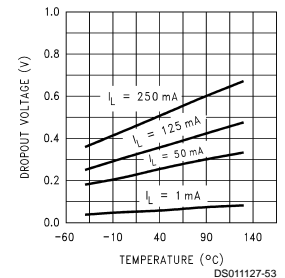

Schematic Diagram

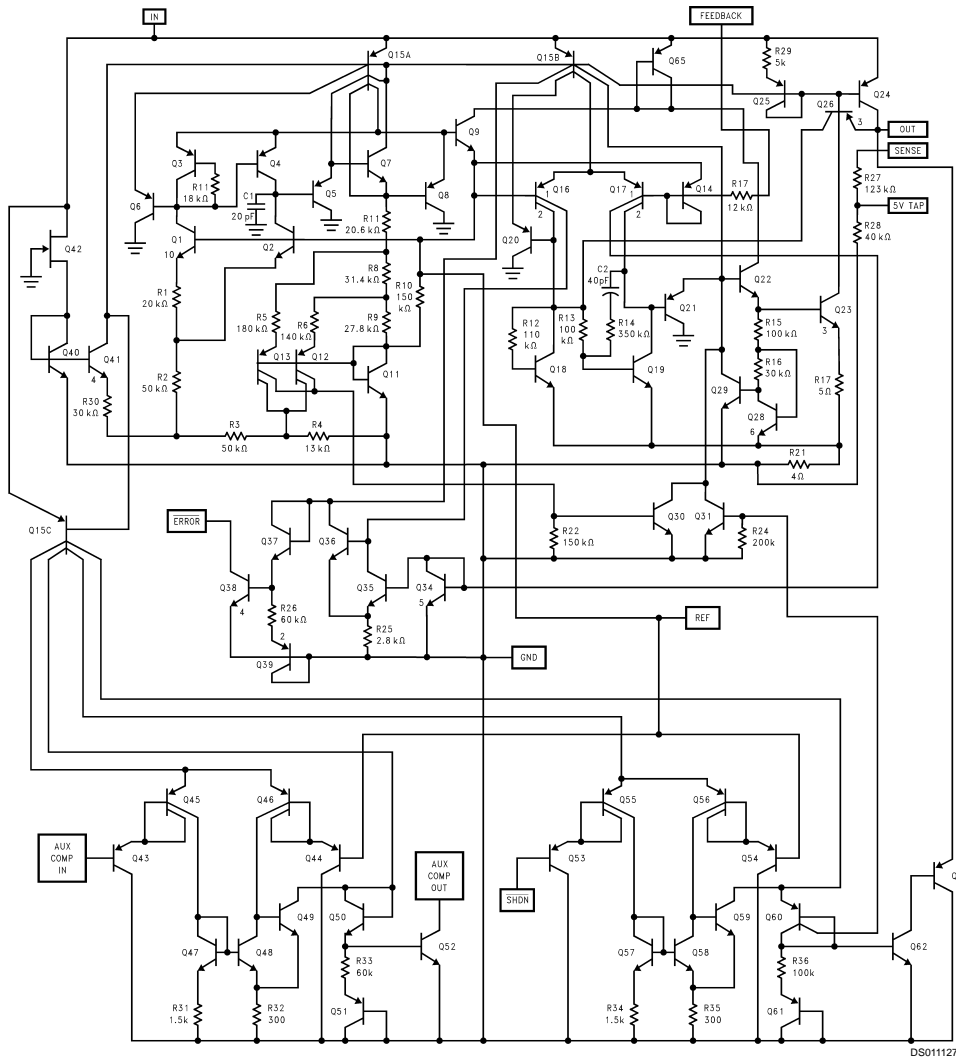

Application Hints

HEATSINK REQUIREMENTS (Industrial Temperature Range Devices)

The maximum allowable power dissipation for the LP2952/LP2953 is limited by the maximum junction temperature (+125°C) and the external factors that determine how quickly heat flows away from the part: the *ambient temperature* and the *junction-to-ambient thermal resistance* for the specific application.

The industrial temperature range ($-40^{\circ}\text{C} \leq T_J \leq +125^{\circ}\text{C}$) parts are manufactured in plastic DIP and surface mount packages which contain a copper lead frame that allows heat to be effectively conducted away from the die, through

the ground pins of the IC, and into the copper of the PC board. Details on heatsinking using PC board copper are covered later.

To determine if a heatsink is required, the maximum power dissipated by the regulator, $P(\text{max})$, must be calculated. It is important to remember that if the regulator is powered from a transformer connected to the AC line, the **maximum specified AC input voltage** must be used (since this produces the maximum DC input voltage to the regulator). *Figure 1* shows the voltages and currents which are present in the circuit. The formula for calculating the power dissipated in the regulator is also shown in *Figure 1*:

Application Hints (Continued)

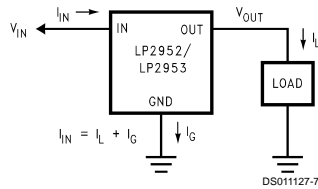

**FIGURE 1. $P_{TOTAL} = (V_{IN} - V_{OUT}) I_L + (V_{IN}) I_G$
Current/Voltage Diagram**

The next parameter which must be calculated is the maximum allowable temperature rise, $T_R(max)$. This is calculated by using the formula:

$$T_R(max) = T_J(max) - T_A(max) \theta_{(J-A)} = T_R(max)/P(max)$$

where: $T_J(max)$ is the maximum allowable junction temperature

$T_A(max)$ is the maximum ambient temperature

Using the calculated values for $T_R(max)$ and $P(max)$, the required value for junction-to-ambient thermal resistance, $\theta_{(J-A)}$, can now be found:

The heatsink is made using the PC board copper. The heat is conducted from the die, through the lead frame (inside the part), and out the pins which are soldered to the PC board. The pins used for heat conduction are given in *Table 1*.

TABLE 1. Heat Conducting Pins

Part	Package	Pins
LP2952IN, LP2952AIN, LP2952IN-3.3, LP2952AIN-3.3	14-Pin DIP	3, 4, 5, 10, 11, 12
LP2953IN, LP2953AIN, LP2953IN-3.3, LP2953AIN-3.3	16-Pin DIP	4, 5, 12, 13
LP2952IM, LP2952AIM, LP2952IM-3.3, LP2952AIM-3.3, LP2953IM, LP2953AIM, LP2953IM-3.3, LP2953AIM-3.3	16-Pin Surface Mount	1, 8, 9, 16

Figure 2 shows copper patterns which may be used to dissipate heat from the LP2952 and LP2953. *Table 2* shows some values of junction-to-ambient thermal resistance (θ_{J-A}) for values of L and W for 1 oz. copper.

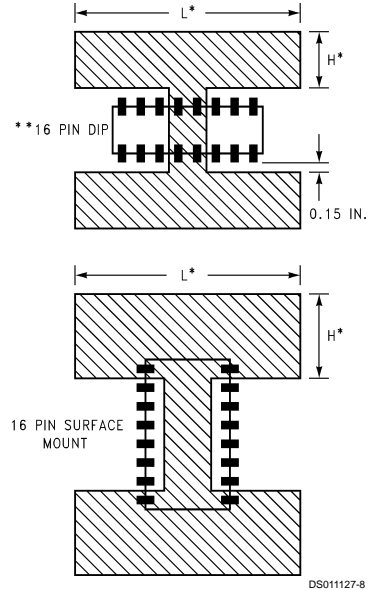

* For best results, use $L = 2H$

** 14-Pin DIP is similar, refer to *Table 1* for pins designated for heatsinking.

FIGURE 2. Copper Heatsink Patterns

TABLE 2. Thermal Resistance for Various Copper Heatsink Patterns

Package	L (in.)	H (in.)	θ_{J-A} ($^{\circ}C/W$)
16-Pin DIP	1	0.5	70
	2	1	60
	3	1.5	58
	4	0.19	66
14-Pin DIP	6	0.19	66
	1	0.5	65
	2	1	51
Surface Mount	3	1.5	49
	1	0.5	83
	2	1	70
	3	1.5	67
	6	0.19	69
	4	0.19	71
	2	0.19	73

HEATSINK REQUIREMENTS (Military Temperature Range Devices)

The maximum allowable power dissipation for the LP2953AMJ is limited by the maximum junction temperature ($+150^{\circ}C$) and the two parameters that determine how quickly heat flows away from the die: *the ambient temperature and the junction-to-ambient thermal resistance of the part.*

The military temperature range ($-55^{\circ}C \leq T_J \leq +150^{\circ}C$) parts are manufactured in ceramic DIP packages which contain a

Application Hints (Continued)

KOVAR lead frame (unlike the industrial parts, which have a copper lead frame). The KOVAR material is necessary to attain the hermetic seal required in military applications.

The KOVAR lead frame does not conduct heat as well as copper, which means that the PC board copper can not be used to significantly reduce the overall junction-to-ambient thermal resistance in applications using the LP2953AMJ part.

The power dissipation calculations for military applications are done exactly the same as was detailed in the previous section, with one important exception: the value for $\theta_{(J-A)}$, the junction-to-ambient thermal resistance, is fixed at 95°C/W and can not be changed by adding copper foil patterns to the PC board. This leads to an important fact: The maximum allowable power dissipation in any application using the LP2953AMJ is dependent only on the ambient temperature:

$$P(\max) = T_{R(\max)} / \theta_{(J-A)}$$

$$P(\max) = \frac{T_{J(\max)} - T_{A(\max)}}{\theta_{(J-A)}}$$

$$P(\max) = \frac{150 - T_{A(\max)}}{95}$$

Figure 3 shows a graph of maximum allowable power dissipation vs. ambient temperature for the LP2953AMJ, made using the 95°C/W value for $\theta_{(J-A)}$ and assuming a maximum junction temperature of 150°C (caution: the maximum ambient temperature which will be reached in a given application must always be used to calculate maximum allowable power dissipation).

EXTERNAL CAPACITORS

A 2.2 µF (or greater) capacitor is required between the output pin and ground to assure stability when the output is set to 5V. Without this capacitor, the part will oscillate. Most type of tantalum or aluminum electrolytics will work here. Film types will work, but are more expensive. Many aluminum electrolytics contain electrolytes which freeze at -30°C, which requires the use of solid tantalums below -25°C. The important parameters of the capacitor are an ESR of about 5Ω or less and a resonant frequency above 500 kHz (the ESR may increase by a factor of 20 or 30 as the temperature is reduced from 25°C to -30°C). The value of this capacitor may be increased without limit.

At lower values of output current, less output capacitance is required for stability. The capacitor can be reduced to 0.68 µF for currents below 10 mA or 0.22 µF for currents below 1 mA.

Programming the output for voltages below 5V runs the error amplifier at lower gains requiring more output capacitance for stability. At 3.3V output, a minimum of 4.7 µF is required. For the worst-case condition of 1.23V output and 250 mA of load current, a 6.8 µF (or larger) capacitor should be used.

A 1 µF capacitor should be placed from the input pin to ground if there is more than 10 inches of wire between the input and the AC filter capacitor or if a battery input is used.

Stray capacitance to the Feedback terminal can cause instability. This problem is most likely to appear when using high value external resistors to set the output voltage. Adding a 100 pF capacitor between the Output and Feedback pins and increasing the output capacitance to 6.8 µF (or greater) will cure the problem.

MINIMUM LOAD

When setting the output voltage using an external resistive divider, a minimum current of 1 µA is recommended through the resistors to provide a minimum load.

It should be noted that a minimum load current is specified in several of the electrical characteristic test conditions, so this value must be used to obtain correlation on these tested limits.

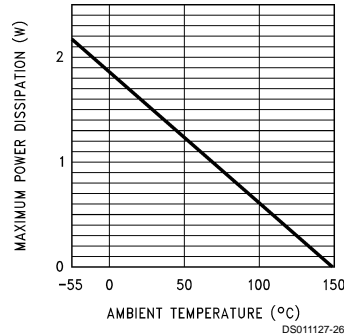

FIGURE 3. Power Derating Curve for LP2953AMJ

PROGRAMMING THE OUTPUT VOLTAGE

The regulator may be pin-strapped for 5V operation using its internal resistive divider by tying the Output and Sense pins together and also tying the Feedback and 5V Tap pins together.

Alternatively, it may be programmed for any voltage between the 1.23V reference and the 30V maximum rating using an external pair of resistors (see Figure 4). The complete equation for the output voltage is:

$$V_{OUT} = V_{REF} \times \left(1 + \frac{R1}{R2} \right) + (I_{FB} \times R1)$$

where V_{REF} is the 1.23V reference and I_{FB} is the Feedback pin bias current (-20 nA typical). The minimum recommended load current of 1 µA sets an upper limit of 1.2 MΩ on the value of R2 in cases where the regulator must work with no load (see MINIMUM LOAD). I_{FB} will produce a typical 2% error in V_{OUT} which can be eliminated at room temperature by trimming R1. For better accuracy, choosing R2 = 100 kΩ will reduce this error to 0.17% while increasing the resistor program current to 12 µA. Since the typical quiescent current is 120 µA, this added current is negligible.

Application Hints (Continued)

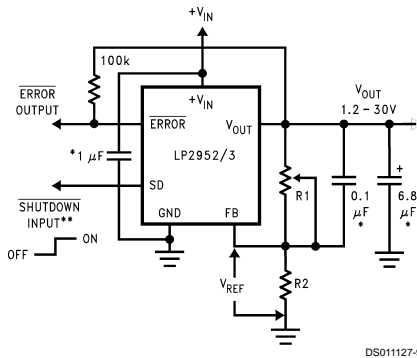

* See Application Hints
 ** Drive with TTL-low to shut down

FIGURE 4. Adjustable Regulator

DROPOUT VOLTAGE

The dropout voltage of the regulator is defined as the minimum input-to-output voltage differential required for the output voltage to stay within 100 mV of the output voltage measured with a 1V differential. The dropout voltage is independent of the programmed output voltage.

DROPOUT DETECTION COMPARATOR

This comparator produces a logic "LOW" whenever the output falls out of regulation by more than about 5%. This figure results from the comparator's built-in offset of 60 mV divided by the 1.23V reference (refer to block diagrams on page 1). The 5% low trip level remains constant regardless of the programmed output voltage. An out-of-regulation condition can result from low input voltage, current limiting, or thermal limiting.

Figure 5 gives a timing diagram showing the relationship between the output voltage, the ERROR output, and input voltage as the input voltage is ramped up and down to a regulator programmed for 5V output. The ERROR signal becomes low at about 1.3V input. It goes high at about 5V input, where the output equals 4.75V. Since the dropout voltage is load dependent, the input voltage trip points will vary with load current. The output voltage trip point does not vary.

The comparator has an open-collector output which requires an external pull-up resistor. This resistor may be connected to the regulator output or some other supply voltage. Using the regulator output prevents an invalid "HIGH" on the comparator output which occurs if it is pulled up to an external voltage while the regulator input voltage is reduced below 1.3V. In selecting a value for the pull-up resistor, note that while the output can sink 400 µA, this current adds to battery drain. Suggested values range from 100 kΩ to 1 MΩ. This resistor is not required if the output is unused.

When $V_{IN} \leq 1.3V$, the error flag pin becomes a high impedance, allowing the error flag voltage to rise to its pull-up voltage. Using V_{OUT} as the pull-up voltage (rather than an external 5V source) will keep the error flag voltage below 1.2V (typical) in this condition. The user may wish to divide down the error flag voltage using equal-value resistors (10 kΩ suggested) to ensure a low-level logic signal during any fault condition, while still allowing a valid high logic level during normal operation.

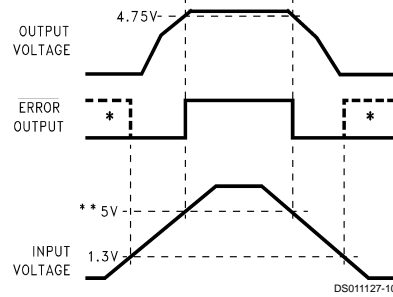

* In shutdown mode, ERROR will go high if it has been pulled up to an external supply. To avoid this invalid response, pull up to regulator output.
 ** Exact value depends on dropout voltage. (See Application Hints)

FIGURE 5. ERROR Output Timing

OUTPUT ISOLATION

The regulator output can be left connected to an active voltage source (such as a battery) with the regulator input power shut off, as long as the regulator ground pin is connected to ground. If the ground pin is left floating, damage to the regulator can occur if the output is pulled up by an external voltage source.

REDUCING OUTPUT NOISE

In reference applications it may be advantageous to reduce the AC noise present on the output. One method is to reduce regulator bandwidth by increasing output capacitance. This is relatively inefficient, since large increases in capacitance are required to get significant improvement.

Noise can be reduced more effectively by a bypass capacitor placed across R1 (refer to Figure 4). The formula for selecting the capacitor to be used is:

$$C_B = \frac{1}{2\pi R_1 \times 20 \text{ Hz}}$$

This gives a value of about 0.1 µF. When this is used, the output capacitor must be 6.8 µF (or greater) to maintain stability. The 0.1 µF capacitor reduces the high frequency gain of the circuit to unity, lowering the output noise from 260 µV to 80 µV using a 10 Hz to 100 kHz bandwidth. Also, noise is no longer proportional to the output voltage, so improvements are more pronounced at high output voltages.

AUXILIARY COMPARATOR (LP2953 only)

The LP2953 contains an auxiliary comparator whose inverting input is connected to the 1.23V reference. The auxiliary comparator has an open-collector output whose electrical characteristics are similar to the dropout detection comparator. The non-inverting input and output are brought out for external connections.

SHUTDOWN INPUT

A logic-level signal will shut off the regulator output when a "LOW" (<1.2V) is applied to the Shutdown input.

To prevent possible mis-operation, the Shutdown input must be actively terminated. If the input is driven from open-collector logic, a pull-up resistor (20 kΩ to 100 kΩ recommended) should be connected from the Shutdown input to the regulator input.

Application Hints (Continued)

If the Shutdown input is driven from a source that actively pulls high and low (like an op-amp), the pull-up resistor is not required, but may be used.

If the shutdown function is not to be used, the cost of the pull-up resistor can be saved by simply tying the Shutdown input directly to the regulator input.

IMPORTANT: Since the Absolute Maximum Ratings state that the Shutdown input can not go more than 0.3V below

ground, the reverse-battery protection feature which protects the regulator input is sacrificed if the Shutdown input is tied directly to the regulator input.

If reverse-battery protection is required in an application, the pull-up resistor between the Shutdown input and the regulator input must be used.

Typical Applications

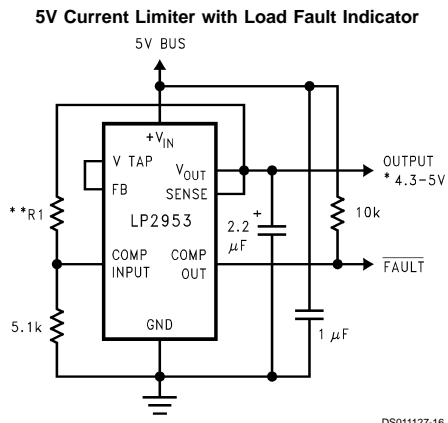
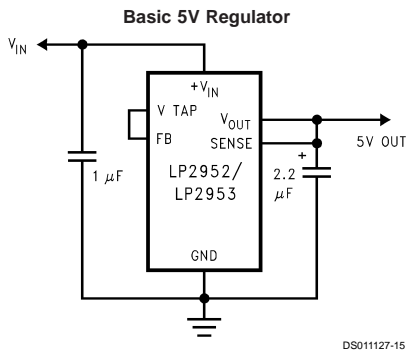

* Output voltage equals +VIN minus dropout voltage, which varies with output current. Current limits at a maximum of 380 mA (typical).
 ** Select R1 so that the comparator input voltage is 1.23V at the output voltage which corresponds to the desired fault current value.

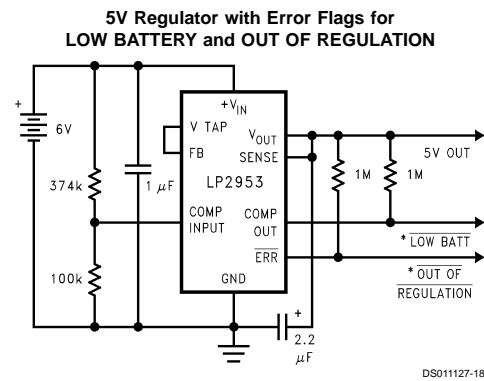
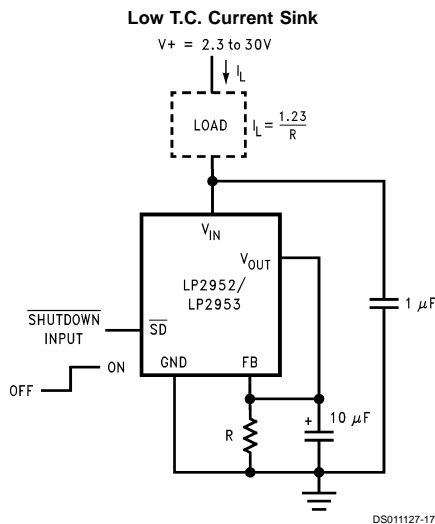

* Connect to Logic or μP control inputs.
 LOW BATT flag warns the user that the battery has discharged down to about 5.8V, giving the user time to recharge the battery or power down some hardware with high power requirements. The output is still in regulation at this time.
 OUT OF REGULATION flag indicates when the battery is almost completely discharged, and can be used to initiate a power-down sequence.

Typical Applications (Continued)

5V Battery Powered Supply with Backup and Low Battery Flag

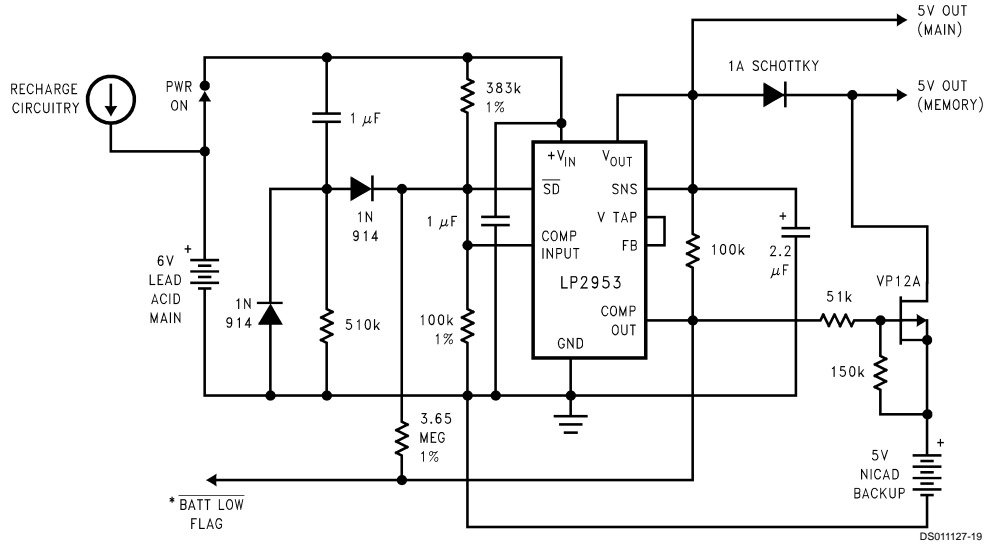

The circuit switches to the NI-CAD backup battery when the main battery voltage drops below about 5.6V, and returns to the main battery when its voltage is recharged to about 6V.

The 5V MAIN output powers circuitry which requires no backup, and the 5V MEMORY output powers critical circuitry which can not be allowed to lose power.

* The BATTERY LOW flag goes low whenever the circuit switches to the NI-CAD backup battery.

5V Regulator with Timed Power-On Reset

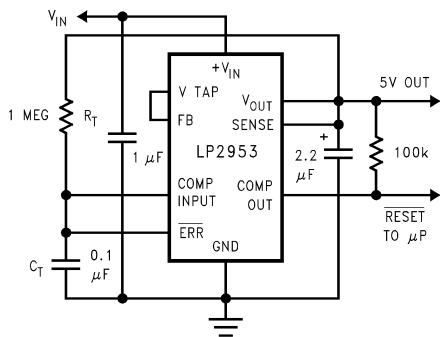

Timing Diagram for Timed Power-On Reset

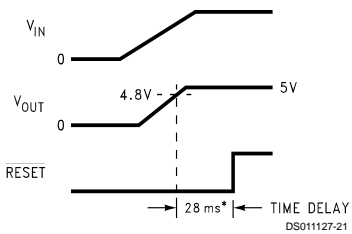

* $R_T = 1 \text{ MEG}$, $C_T = 0.1 \mu\text{F}$

Typical Applications (Continued)

5V Regulator with Snap-On/Snap-Off Feature and Hysteresis

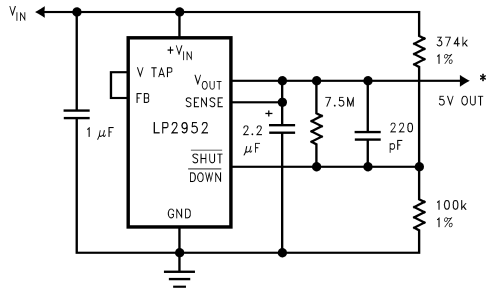

DS011127-22

* Turns ON at $V_{IN} = 5.87V$
Turns OFF at $V_{IN} = 5.64V$
(for component values shown)

5V Regulator with Error Flags for LOW BATTERY and OUT OF REGULATION with SNAP-ON/SNAP-OFF Output

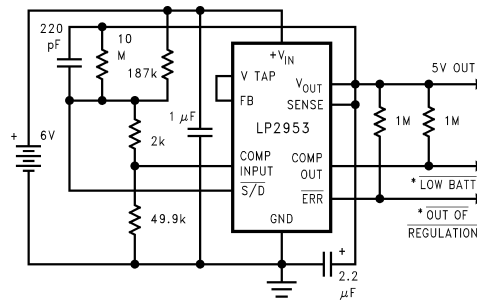

DS011127-23

* Connect to Logic or μP control inputs.
OUTPUT has SNAP-ON/SNAP-OFF feature.
LOW BATT flag warns the user that the battery has discharged down to about 5.8V, giving the user time to recharge the battery or shut down hardware with high power requirements. The output is still in regulation at this time.
OUT OF REGULATION flag goes low if the output goes below about 4.7V, which could occur from a load fault.
OUTPUT has SNAP-ON/SNAP-OFF feature. Regulator snaps ON at about 5.7V input, and OFF at about 5.6V.

5V Regulator with Timed Power-On Reset, Snap-On/Snap-Off Feature and Hysteresis

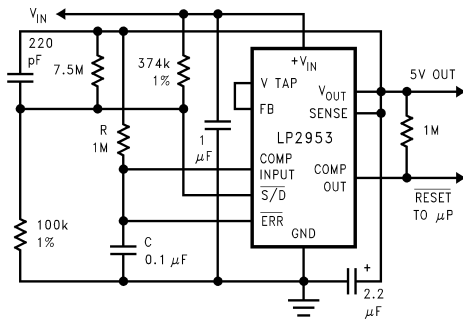

DS011127-24

Timing Diagram

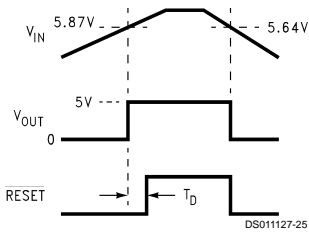

DS011127-25

$T_d = (0.28) RC = 28 \text{ ms}$ for components shown.

Physical Dimensions inches (millimeters) unless otherwise noted

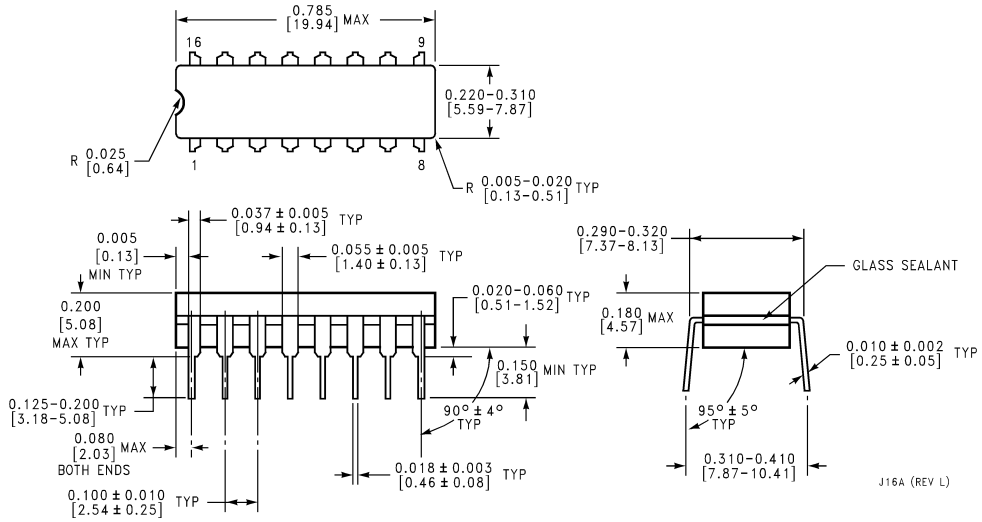

16-Pin Ceramic DIP

Order Number LP2953AMJ/883, 5962-9233601MEA, LP2953AMJ-QMLV, 5962-9233601VEA
NS Package Number J16A

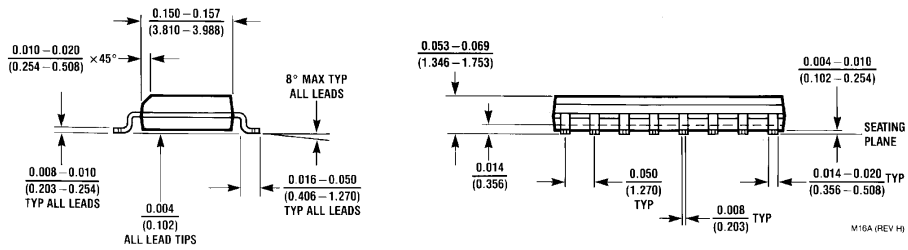
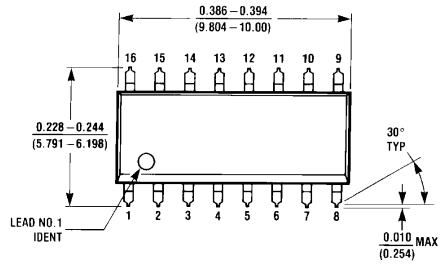

16-Pin Surface Mount

Order Number LP2952IM, LP2952AIM, LP2952IM-3.3, LP2952AIM-3.3,
LP2953IM, LP2953AIM, LP2953IM-3.3 or LP2953AIM-3.3
NS Package Number M16A

Physical Dimensions inches (millimeters) unless otherwise noted (Continued)

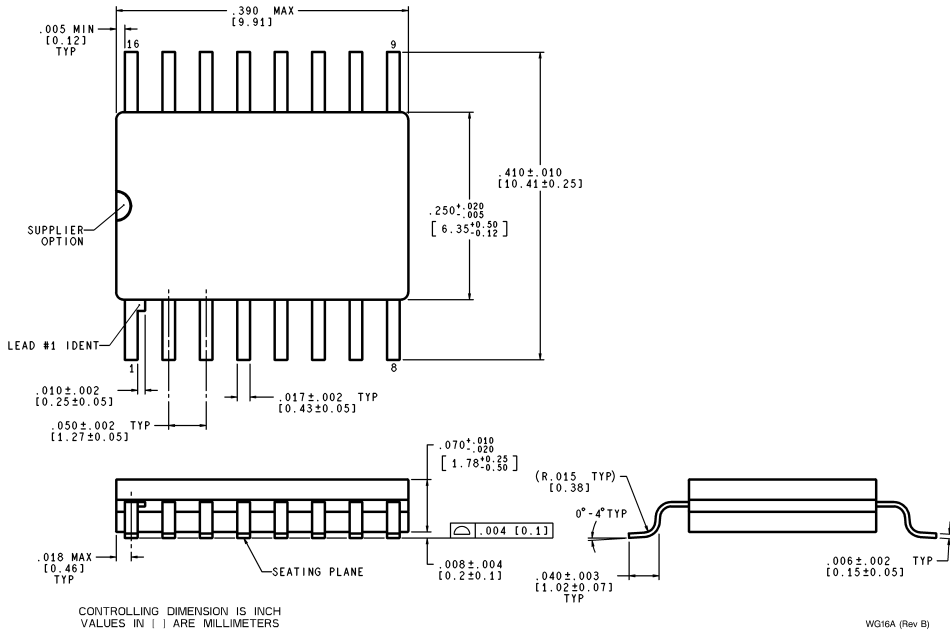

16-Pin Ceramic Surface-Mount
Order Number LP2953AMWG/883, 5962-9233601QXA, LP2953AMWG-QMLV, 5962-9233601VXA
NS Package Number WG16A

LIFE SUPPORT POLICY

NATIONAL'S PRODUCTS ARE NOT AUTHORIZED FOR USE AS CRITICAL COMPONENTS IN LIFE SUPPORT DEVICES OR SYSTEMS WITHOUT THE EXPRESS WRITTEN APPROVAL OF THE PRESIDENT AND GENERAL COUNSEL OF NATIONAL SEMICONDUCTOR CORPORATION. As used herein:

1. Life support devices or systems are devices or systems which, (a) are intended for surgical implant into the body, or (b) support or sustain life, and whose failure to perform when properly used in accordance with instructions for use provided in the labeling, can be reasonably expected to result in a significant injury to the user.
2. A critical component is any component of a life support device or system whose failure to perform can be reasonably expected to cause the failure of the life support device or system, or to affect its safety or effectiveness.

 <p>National Semiconductor Corporation Americas Tel: 1-800-272-9959 Fax: 1-800-737-7018 Email: support@nsc.com www.national.com</p>	<p>National Semiconductor Europe Fax: +49 (0) 1 80-530 85 86 Email: europe.support@nsc.com Deutsch Tel: +49 (0) 1 80-530 85 85 English Tel: +49 (0) 1 80-532 78 32 Français Tel: +49 (0) 1 80-532 93 58 Italiano Tel: +49 (0) 1 80-534 16 80</p>	<p>National Semiconductor Asia Pacific Customer Response Group Tel: 65-2544466 Fax: 65-2504466 Email: sea.support@nsc.com</p>	<p>National Semiconductor Japan Ltd. Tel: 81-3-5639-7560 Fax: 81-3-5639-7507</p>
--	---	---	---

National does not assume any responsibility for use of any circuitry described, no circuit patent licenses are implied and National reserves the right at any time without notice to change said circuitry and specifications.