

## MM54C154/MM74C154 4-Line to 16-Line Decoder/Demultiplexer

### General Description

The MM54C154/MM74C154 one of sixteen decoder is a monolithic complementary MOS (CMOS) integrated circuit constructed with N- and P-channel enhancement transistors. The device is provided with two strobe inputs, both of which must be in the logical "0" state for normal operation. If either strobe input is in the logical "1" state, all 16 outputs will go to the logical "1" state.

To use the product as a demultiplexer, one of the strobe inputs serves as a data input terminal, while the other strobe input must be maintained in the logical "0" state. The information will then be transmitted to the selected output as determined by the 4-line input address.

### Features

- Supply voltage range 3V to 15V
- Tenth power TTL compatible Drive 2 LPTTL loads
- High noise margin 1V guaranteed
- High noise immunity 0.45 V<sub>CC</sub> (typ.)

### Applications

- Automotive
- Data terminals
- Instrumentation
- Medical electronics
- Alarm systems
- Industrial electronics
- Remote metering
- Computers

### Logic & Connection Diagrams

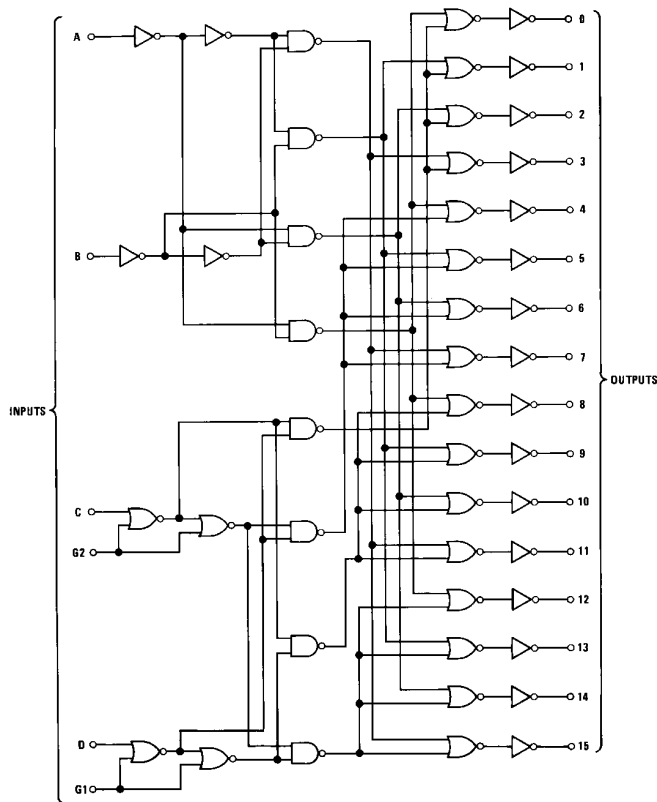

TL/F/5893-1

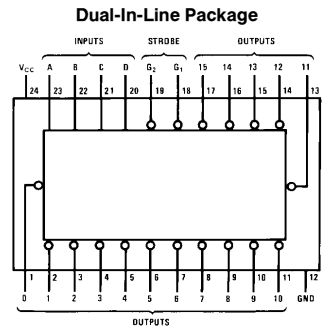

Top View

Order Number MM54C154 or  
MM74C154

MM54C154/MM74C154 4-Line to 16-Line Decoder/Demultiplexer

### Absolute Maximum Ratings (Note 1)

If Military/Aerospace specified devices are required, please contact the National Semiconductor Sales Office/Distributors for availability and specifications.

Voltage at Any Pin	-0.3V to $V_{CC} + 0.3V$
Operating Temperature Range	
MM54C154	-55°C to +125°C
MM74C154	-40°C to +85°C

Storage Temperature Range	-65°C to +150°C
Maximum $V_{CC}$ Voltage	18V
Power Dissipation	
Dual-In-Line	700 mW
Small Outline	500 mW
Operating $V_{CC}$ Range	3V to 15V
Lead Temperature (Soldering, 10 seconds)	260°C

### DC Electrical Characteristics

Min/max limits apply across temperature range unless otherwise noted

Symbol	Parameter	Conditions	Min	Typ	Max	Units
<b>CMOS TO CMOS</b>						
$V_{IN(1)}$	Logical "1" Input Voltage	$V_{CC} = 5.0V$ $V_{CC} = 10V$	3.5 8.0			V V
$V_{IN(0)}$	Logical "0" Input Voltage	$V_{CC} = 5.0V$ $V_{CC} = 10V$			1.5 2.0	V V
$V_{OUT(1)}$	Logical "1" Output Voltage	$V_{CC} = 5.0V, I_O = -10\mu A$ $V_{CC} = 10V, I_O = -10\mu A$	4.5 9.0			V V
$V_{OUT(0)}$	Logical "0" Output Voltage	$V_{CC} = 5.0V, I_O = 10\mu A$ $V_{CC} = 10V, I_O = 10\mu A$			0.5 1.0	V V
$I_{IN(1)}$	Logical "1" Input Current	$V_{CC} = 15V, V_{IN} = 15V$		0.005	1.0	$\mu A$
$I_{IN(0)}$	Logical "0" Input Current	$V_{CC} = 15V, V_{IN} = 0V$	-1.0	-0.005		$\mu A$
$I_{CC}$	Supply Current	$V_{CC} = 15V$		0.05	300	$\mu A$
<b>CMOS TO LPTTL INTERFACE</b>						
$V_{IN(1)}$	Logical "1" Input Voltage	54C $V_{CC} = 4.5V$ 74C $V_{CC} = 4.75V$	$V_{CC} - 1.5$ $V_{CC} - 1.5$			V V
$V_{IN(0)}$	Logical "0" Input Voltage	54C $V_{CC} = 4.5V$ 74C $V_{CC} = 4.75V$			0.8 0.8	V V
$V_{OUT(1)}$	Logical "1" Output Voltage	54C $V_{CC} = 4.5V, I_O = -100\mu A$ 74C $V_{CC} = 4.75V, I_O = -100\mu A$	2.4 2.4			V V
$V_{OUT(0)}$	Logical "0" Output Voltage	54C $V_{CC} = 4.5V, I_O = 360\mu A$ 74C $V_{CC} = 4.75V, I_O = 360\mu A$			0.4 0.4	V V
<b>OUTPUT DRIVE (See 54C/74C Family Characteristics Data Sheet) (Short Circuit Current)</b>						
$I_{SOURCE}$	Output Source Current	$V_{CC} = 5.0V, V_{IN(0)} = 0V$ $T_A = 25^\circ C, V_{OUT} = 0V$	-1.75			mA
$I_{SOURCE}$	Output Source Current	$V_{CC} = 10V, V_{IN(0)} = 0V$ $T_A = 25^\circ C, V_{OUT} = 0V$	-8.0			mA
$I_{SINK}$	Output Sink Current	$V_{CC} = 5.0V, V_{IN(1)} = 5.0V$ $T_A = 25^\circ C, V_{OUT} = V_{CC}$	1.75			mA
$I_{SINK}$	Output Sink Current	$V_{CC} = 10V, V_{IN(1)} = 10V$ $T_A = 25^\circ C, V_{OUT} = V_{CC}$	8.0			mA

**Note 1:** "Absolute Maximum Ratings" are those values beyond which the safety of the device cannot be guaranteed. Except for "Operating Temperature Range" they are not meant to imply that the devices should be operated at these limits. The table of "Electrical Characteristics" provides conditions for actual device operation.

## AC Electrical Characteristics\* $T_A = 25^\circ\text{C}$ , $C_L = 50\text{ pF}$ , unless otherwise noted

Symbol	Parameter	Conditions	Min	Typ	Max	Units
$t_{pd0}$	Propagation Delay to a Logical "0" from Any Input to Any Output	$V_{CC} = 5.0\text{V}$ $V_{CC} = 10\text{V}$		275 100	400 200	ns ns
$t_{pd0}$	Propagation Delay to a Logical "0" from G1 or G2 to Any Output	$V_{CC} = 5.0\text{V}$ $V_{CC} = 10\text{V}$		275 100	400 200	ns ns
$t_{pd0}$	Propagation Delay to a Logical "0" from Any Input to Any Output	$V_{CC} = 5.0\text{V}$ $V_{CC} = 10\text{V}$		265 100	400 200	ns ns
$t_{pd1}$	Propagation Delay to a Logical "1" from G1 or G2 to Any Output	$V_{CC} = 5.0\text{V}$ $V_{CC} = 10\text{V}$		265 100	400 200	ns ns
$C_{IN}$	Input Capacitance	(Note 2)		5.0		pF
$C_{PD}$	Power Dissipation Capacitance	(Note 3)		60		pF

\*AC Parameters are guaranteed by DC correlated testing.

**Note 2:** Capacitance is guaranteed by periodic testing.

**Note 3:**  $C_{PD}$  determines the no load AC power consumption of any CMOS device. For complete explanation see 54C/74C Family Characteristics Application Note AN-90.

### Switching Time Waveforms

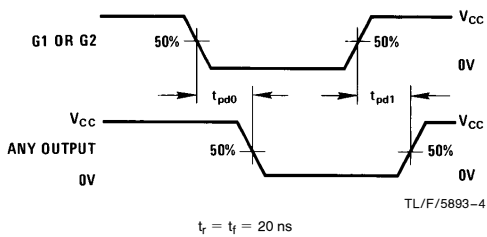
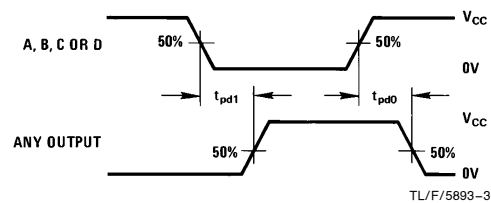

### Truth Table

Inputs					Outputs																	
G1	G2	D	C	B	A	0	1	2	3	4	5	6	7	8	9	10	11	12	13	14	15	
L	L	L	L	L	L	L	H	H	H	H	H	H	H	H	H	H	H	H	H	H	H	H
L	L	L	L	L	H	H	L	H	H	H	H	H	H	H	H	H	H	H	H	H	H	H
L	L	L	L	H	L	H	H	L	H	H	H	H	H	H	H	H	H	H	H	H	H	H
L	L	L	H	L	L	H	H	H	H	L	H	H	H	H	H	H	H	H	H	H	H	H
L	L	L	H	L	H	H	H	H	H	H	L	H	H	H	H	H	H	H	H	H	H	H
L	L	L	H	H	L	H	H	H	H	H	H	L	H	H	H	H	H	H	H	H	H	H
L	L	H	L	L	L	H	H	H	H	H	H	H	L	H	H	H	H	H	H	H	H	H
L	L	H	L	L	H	H	H	H	H	H	H	H	H	L	H	H	H	H	H	H	H	H
L	L	H	L	H	L	H	H	H	H	H	H	H	H	H	L	H	H	H	H	H	H	H
L	L	H	H	L	L	H	H	H	H	H	H	H	H	H	H	L	H	H	H	H	H	H
L	L	H	H	L	H	H	H	H	H	H	H	H	H	H	H	H	L	H	H	H	H	H
L	L	H	H	H	L	H	H	H	H	H	H	H	H	H	H	H	H	L	H	H	H	H
L	L	H	H	H	H	H	H	H	H	H	H	H	H	H	H	H	H	H	L	H	H	H
L	H	X	X	X	X	H	H	H	H	H	H	H	H	H	H	H	H	H	H	H	H	H
H	L	X	X	X	X	H	H	H	H	H	H	H	H	H	H	H	H	H	H	H	H	H
H	H	X	X	X	X	H	H	H	H	H	H	H	H	H	H	H	H	H	H	H	H	H

X = "Don't Care" Condition

**Physical Dimensions** inches (millimeters)

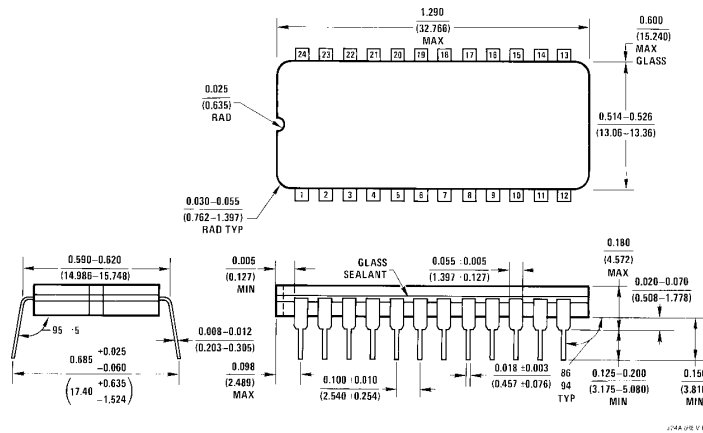

**Ceramic Dual-In-Line Package (J)**  
**Order Number MM54C154J or MM74C154J**  
**NS Package Number J24A**

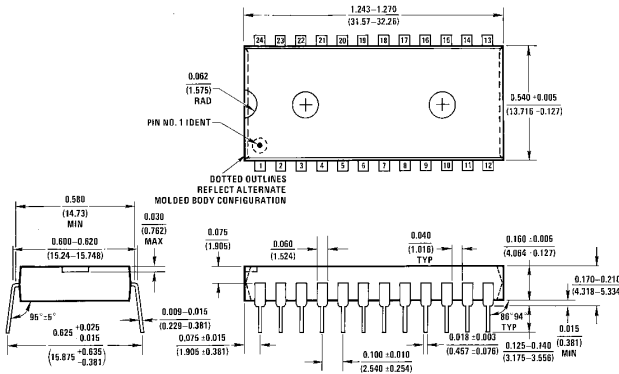

**Molded Dual-In-Line Package (N)**  
**Order Number MM54C154N or MM74C154N**  
**NS Package Number N24A**

**LIFE SUPPORT POLICY**

NATIONAL'S PRODUCTS ARE NOT AUTHORIZED FOR USE AS CRITICAL COMPONENTS IN LIFE SUPPORT DEVICES OR SYSTEMS WITHOUT THE EXPRESS WRITTEN APPROVAL OF THE PRESIDENT OF NATIONAL SEMICONDUCTOR CORPORATION. As used herein:

1. Life support devices or systems are devices or systems which, (a) are intended for surgical implant into the body, or (b) support or sustain life, and whose failure to perform, when properly used in accordance with instructions for use provided in the labeling, can be reasonably expected to result in a significant injury to the user.
2. A critical component is any component of a life support device or system whose failure to perform can be reasonably expected to cause the failure of the life support device or system, or to affect its safety or effectiveness.



**National Semiconductor Corporation**  
 1111 West Bardin Road  
 Arlington, TX 76017  
 Tel: 1(800) 272-9959  
 Fax: 1(800) 737-7018

**National Semiconductor Europe**  
 Fax: (+49) 0-180-530 85 86  
 Email: cnjwge@tevm2.nsc.com  
 Deutsch Tel: (+49) 0-180-530 85 85  
 English Tel: (+49) 0-180-532 78 32  
 Français Tel: (+49) 0-180-532 93 58  
 Italiano Tel: (+49) 0-180-534 16 80

**National Semiconductor Hong Kong Ltd.**  
 13th Floor, Straight Block,  
 Ocean Centre, 5 Canton Rd.  
 Tsimshatsui, Kowloon  
 Hong Kong  
 Tel: (852) 2737-1600  
 Fax: (852) 2736-9960

**National Semiconductor Japan Ltd.**  
 Tel: 81-043-299-2309  
 Fax: 81-043-299-2408

National does not assume any responsibility for use of any circuitry described, no circuit patent licenses are implied and National reserves the right at any time without notice to change said circuitry and specifications.