

MM54C901/MM74C901 Hex Inverting TTL Buffer
MM54C902/MM74C902 Hex Non-Inverting TTL Buffer
MM54C903/MM74C903 Hex Inverting CMOS Buffer
MM54C904/MM74C904 Hex Non-Inverting CMOS Buffer

General Description

These hex buffers employ complementary MOS to achieve wide supply operating range, low power consumption, and high noise immunity. These buffers provide direct interface from PMOS into CMOS or TTL and direct interface from CMOS to TTL or CMOS operating at a reduced V_{CC} supply.

Features

- Wide supply voltage range 3.0V to 15V
- Guaranteed noise margin 1.0V
- High noise immunity 0.45 V_{CC} (typ.)
- TTL compatibility Fan out of 2 driving standard TTL

Connection Diagrams

Dual-In-Line Package
MM54C901/MM74C901
MM54C903/MM74C903

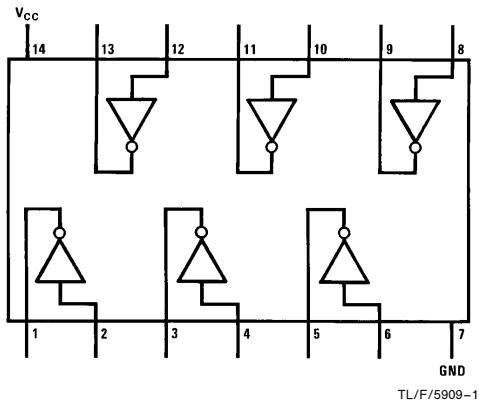

Top View

Order Number MM54C901,
 MM74C901, MM54C903 or MM74C903

Dual-In-Line Package
MM54C902/MM74C902
MM54C904/MM74C904

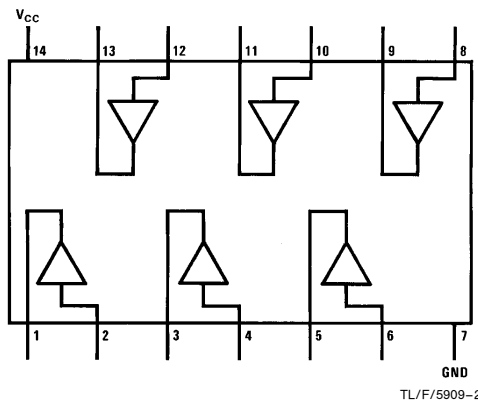

Top View

Order Number MM54C902,
 MM74C902, MM54C904 or MM74C904

MM54C901/MM74C901 (TTL), MM54C903/MM74C903 (CMOS) Hex Inverting Buffer
MM54C902/MM74C902 (TTL), MM54C904/MM74C904 (CMOS) Hex Non-Inverting Buffer

Absolute Maximum Ratings (Note 1)

If Military/Aerospace specified devices are required, please contact the National Semiconductor Sales Office/Distributors for availability and specifications.

Voltage at Any Pin	-0.3V to $V_{CC} + 0.3V$
Voltage at Any Input Pin	
MM54C901/MM74C901	-0.3V to +15V
MM54C902/MM74C902	-0.3V to +15V
MM54C903/MM74C903	$V_{CC} - 17V$ to $V_{CC} + 0.3V$
MM54C904/MM74C904	$V_{CC} - 17V$ to $V_{CC} + 0.3V$
Storage Temperature Range (T_S)	-65°C to +150°C
Power Dissipation (P_D)	
Dual-In-Line	700 mW
Small Outline	500 mW

Operating Temperature Range (T_A)	
MM54C901, MM54C902, MM54C903, MM54C904	-55°C to +125°C
MM74C901, MM74C902, MM74C903, MM74C904	-40°C to +85°C
Operating V_{CC} Range	3.0V to 15V
Absolute Maximum V_{CC}	18V
Lead Temperature (T_L)	
(Soldering, 10 seconds)	260°C

DC Electrical Characteristics Min/Max limits apply across temperature range unless otherwise noted

Symbol	Parameter	Conditions	Min	Typ	Max	Units
CMOS TO CMOS						
$V_{IN(1)}$	Logical "1" Input Voltage	$V_{CC} = 5.0V$ $V_{CC} = 10V$	3.5 8.0			V V
$V_{IN(0)}$	Logical "0" Input Voltage	$V_{CC} = 5.0V$ $V_{CC} = 10V$			1.5 2.0	V V
$V_{OUT(1)}$	Logical "1" Output Voltage	$V_{CC} = 5.0V, I_O = -10 \mu A$ $V_{CC} = 10V, I_O = -10 \mu A$	4.5 9.0			V V
$V_{OUT(0)}$	Logical "0" Output Voltage	$V_{CC} = 5.0V$ $V_{CC} = 10V$			0.5 1.0	V V
$I_{IN(1)}$	Logical "1" Input Current	$V_{CC} = 15V, V_{IN} = 15V$		0.005	1.0	μA
$I_{IN(0)}$	Logical "0" Input Current	$V_{CC} = 15V, V_{IN} = 0V$	-1.0	-0.005		μA
I_{CC}	Supply Current	$V_{CC} = 15V$		0.05	15	μA
TTL TO CMOS						
$V_{IN(1)}$	Logical "1" Input Voltage	54C $V_{CC} = 4.5V$ 74C $V_{CC} = 4.75V$	$V_{CC} - 1.5$ $V_{CC} - 1.5$			V V
$V_{IN(0)}$	Logical "0" Input Voltage	54C $V_{CC} = 4.5V$ 74C $V_{CC} = 4.75V$			0.8 0.8	V V
CMOS TO TTL						
$V_{IN(1)}$	Logical "1" Input Voltage MM54C901, MM54C903 MM54C902, MM54C904 MM74C901, MM74C903 MM74C902, MM74C904	$V_{CC} = 4.5V$ $V_{CC} = 4.5V$ $V_{CC} = 4.75V$ $V_{CC} = 4.75V$	4.0 $V_{CC} - 1.5$ 4.25 $V_{CC} - 1.5$			V V V V
$V_{IN(0)}$	Logical "0" Input Voltage MM54C901, MM54C903 MM54C902, MM54C904 MM74C901, MM74C903 MM74C902, MM74C904	$V_{CC} = 4.5V$ $V_{CC} = 4.5V$ $V_{CC} = 4.75V$ $V_{CC} = 4.75V$			1.0 1.5 1.0 1.5	V V V V
$V_{OUT(1)}$	Logical "1" Output Voltage	54C $V_{CC} = 4.5V, I_O = -800 \mu A$ 74C $V_{CC} = 4.75V, I_O = -800 \mu A$	2.4 2.4			V V
$V_{OUT(0)}$	Logical "0" Output Voltage MM54C901, MM54C903 MM54C902, MM54C904 MM74C901, MM74C903 MM74C902, MM74C904	$V_{CC} = 4.5V, I_O = 2.6 mA$ $V_{CC} = 4.5V, I_O = 3.2 mA$ $V_{CC} = 4.75V, I_O = 2.6 mA$ $V_{CC} = 4.75V, I_O = 3.2 mA$			0.4 0.4 0.4 0.4	V V V V

DC Electrical Characteristics (Continued)

Min/Max limits apply across temperature range unless otherwise noted

Symbol	Parameter	Conditions	Min	Typ	Max	Units
OUTPUT DRIVE (See 54C/74C Family Characteristics Data Sheet) (Short Circuit Current) (MM54C901/MM74C901, MM54C903/MM74C903)						
I _{SOURCE}	Output Source Current (P-Channel)	V _{CC} = 5.0V, V _{OUT} = 0V T _A = 25°C, V _{IN} = 0V	-5.0			mA
I _{SOURCE}	Output Source Current (P-Channel)	V _{CC} = 10V, V _{OUT} = 0V T _A = 25°C, V _{IN} = 0V	-20			mA
I _{SINK}	Output Sink Current (N-Channel)	V _{CC} = 5.0V, V _{OUT} = V _{CC} T _A = 25°C, V _{IN} = V _{CC}	9.0			mA
I _{SINK}	Output Sink Current (N-Channel)	V _{CC} = 5.0V, V _{OUT} = 0.4V T _A = 25°C, V _{IN} = V _{CC}	3.8			mA
(MM54C902/MM74C902, MM54C904/MM74C904)						
I _{SOURCE}	Output Source Current (P-Channel)	V _{CC} = 5.0V, V _{OUT} = 0V T _A = 25°C, V _{IN} = V _{CC}	-5.0			mA
I _{SOURCE}	Output Source Current (P-Channel)	V _{CC} = 10V, V _{OUT} = 0V T _A = 25°C, V _{IN} = V _{CC}	-20			mA
I _{SINK}	Output Sink Current (N-Channel)	V _{CC} = 5.0V, V _{OUT} = V _{CC} T _A = 25°C, V _{IN} = 0V	9.0			mA
I _{SINK}	Output Sink Current (N-Channel)	V _{CC} = 5.0V, V _{OUT} = 0.4V T _A = 25°C, V _{IN} = 0V	3.8			mA

AC Electrical Characteristics* T_A = 25°C, C_L = 50 pF, unless otherwise noted

Symbol	Parameter	Conditions	Min	Typ	Max	Units
MM54C901/MM74C901, MM54C903/MM74C903						
t _{pd1}	Propagation Delay Time to a Logical "1"	V _{CC} = 5.0V V _{CC} = 10V		38 22	70 30	ns ns
t _{pd0}	Propagation Delay Time to a Logical "0"	V _{CC} = 5.0V V _{CC} = 10V		21 13	35 20	ns ns
C _{IN}	Input Capacitance	Any Input (Note 2)		14		pF
C _{PD}	Power Dissipation Capacity	(Note 3) Per Buffer		30		pF
MM54C902/MM74C902, MM54C904/MM74C904						
t _{pd1}	Propagation Delay Time to a Logical "1"	V _{CC} = 5.0V V _{CC} = 10V		57 27	90 40	ns ns
t _{pd0}	Propagation Delay Time to a Logical "0"	V _{CC} = 5.0V V _{CC} = 10V		54 25	90 40	ns ns
C _{IN}	Input Capacitance	Any Input (Note 2)		5.0		pF
C _{PD}	Power Dissipation Capacity	(Note 3) Per Buffer		50		pF

*AC Parameters are guaranteed by DC correlated testing.

Note 1: "Absolute Maximum Ratings" are those values beyond which the safety of the device cannot be guaranteed. Except for "Operating Temperature Range" they are not meant to imply that the devices should be operated at these limits. The table of "Electrical Characteristics" provides conditions for actual device operation.

Note 2: Capacitance is guaranteed by periodic testing.

Note 3: C_{PD} determines the no load AC power consumption of any CMOS device. For complete explanation see 54C/74C Family Characteristics application note AN-90.

Logic Diagrams

MM54C901/MM74C901
CMOS to TTL Inverting Buffer

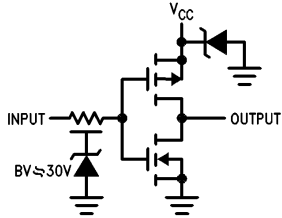

TL/F/5909-3

MM54C903/MM74C903
PMOS to TTL or CMOS Inverting Buffer

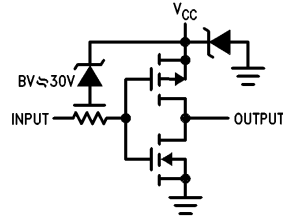

TL/F/5909-4

MM54C902/MM74C902
CMOS to TTL Buffer

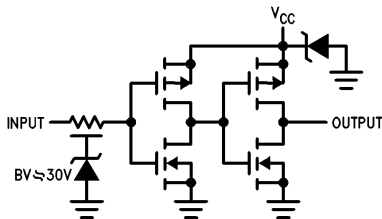

TL/F/5909-5

MM54C904/MM74C904
PMOS to TTL or CMOS Buffer

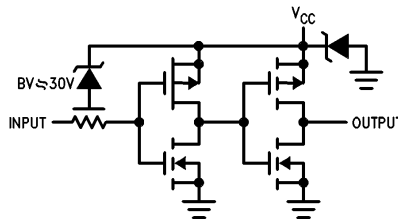

TL/F/5909-6

Typical Applications

PMOS to CMOS or TTL Interface

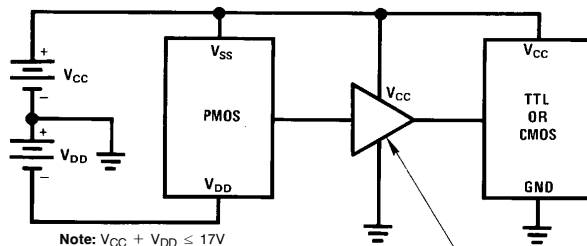

Note: $V_{CC} + V_{DD} \leq 17V$
 $V_{CC} \leq 15V$

[MM54C903/MM74C903 or
MM54C904/MM74C904]

TL/F/5909-7

CMOS to TTL or CMOS at a Lower V_{CC}

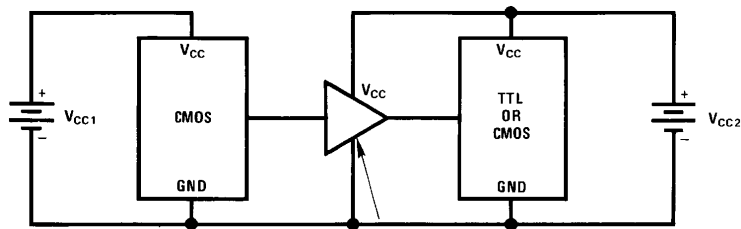

Note: $V_{CC1} = V_{CC2}$

[MM54C901/MM74C901 or
MM54C902/MM74C902]

TL/F/5909-8

AC Test Circuit and Switching Time Waveforms

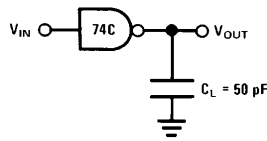

TL/F/5909-9
 Note: Delays measured with input t_r , $t_f = 20$ ns.

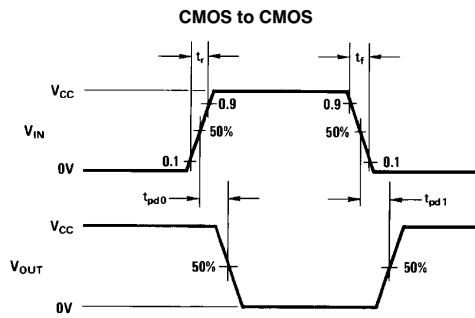

TL/F/5909-10

Typical Performance Characteristics

Typical Propagation Delay to a Logical "0" for the MM54C901/MM74C901 and MM54C903/MM74C903

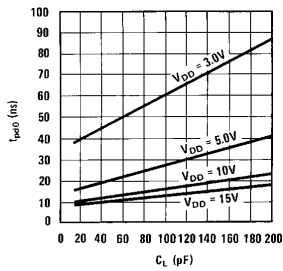

TL/F/5909-11

Typical Propagation Delay to a Logical "1" for the MM54C901/MM74C901 and MM54C903/MM74C903

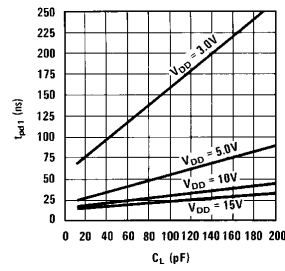

TL/F/5909-13

Typical Propagation Delay to a Logical "0" for the MM54C902/MM74C902 and MM54C904/MM74C904

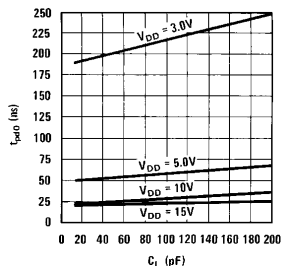

TL/F/5909-14

Typical Propagation Delay to a Logical "1" for the MM54C902/MM74C902 and MM54C904/MM74C904

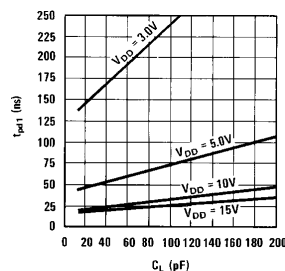

TL/F/5909-12

Physical Dimensions inches (millimeters)

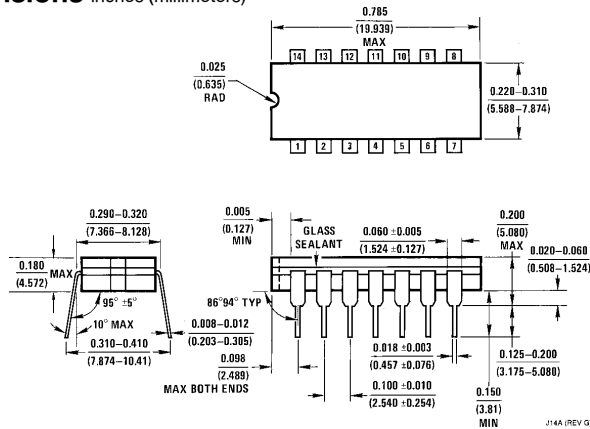

Ceramic Dual-In-Line Package (J)
 Order Number MM54C901J, MM74C901J, MM54C902J,
 MM74C902J, MM54C903J, MM74C903J, MM54C904J or MM74C904J
 NS Package Number J14A

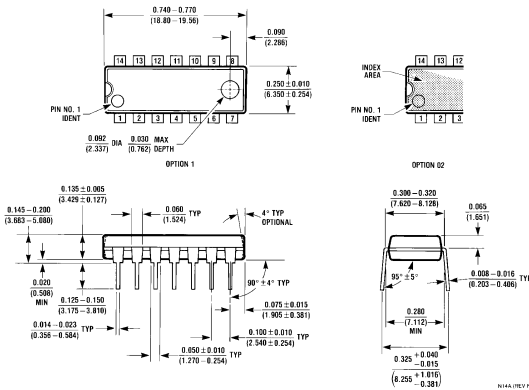

Molded Dual-In-Line Package (N)
 Order Number MM54C901N, MM74C901N, MM54C902N,
 MM74C902N, MM54C903N, MM74C903N, MM54C904N or MM74C904N
 NS Package Number N14A

LIFE SUPPORT POLICY

NATIONAL'S PRODUCTS ARE NOT AUTHORIZED FOR USE AS CRITICAL COMPONENTS IN LIFE SUPPORT DEVICES OR SYSTEMS WITHOUT THE EXPRESS WRITTEN APPROVAL OF THE PRESIDENT OF NATIONAL SEMICONDUCTOR CORPORATION. As used herein:

1. Life support devices or systems are devices or systems which, (a) are intended for surgical implant into the body, or (b) support or sustain life, and whose failure to perform, when properly used in accordance with instructions for use provided in the labeling, can be reasonably expected to result in a significant injury to the user.
2. A critical component is any component of a life support device or system whose failure to perform can be reasonably expected to cause the failure of the life support device or system, or to affect its safety or effectiveness.



National Semiconductor Corporation
 1111 West Bardin Road
 Arlington, TX 76017
 Tel: 1(800) 272-9959
 Fax: 1(800) 737-7018

National Semiconductor Europe
 Fax: (+49) 0-180-530 85 86
 Email: cnjwge@tevm2.nsc.com
 Deutsch Tel: (+49) 0-180-530 85 85
 English Tel: (+49) 0-180-532 78 32
 Français Tel: (+49) 0-180-532 93 58
 Italiano Tel: (+49) 0-180-534 16 80

National Semiconductor Hong Kong Ltd.
 13th Floor, Straight Block,
 Ocean Centre, 5 Canton Rd.
 Tsimshatsui, Kowloon
 Hong Kong
 Tel: (852) 2737-1600
 Fax: (852) 2736-9960

National Semiconductor Japan Ltd.
 Tel: 81-043-299-2309
 Fax: 81-043-299-2408

National does not assume any responsibility for use of any circuitry described, no circuit patent licenses are implied and National reserves the right at any time without notice to change said circuitry and specifications.