

PC87366

128-Pin LPC SuperI/O with System Hardware Monitoring, MIDI and Game Ports

General Description

The PC87366, a member of National Semiconductor's 128-pin LPC SuperI/O family, combines National's System Hardware Monitoring capability with a Musical Instrument Digital Interface (MIDI) Port and game port inputs for up to two joysticks. The PC87366 is PC99 and ACPI compliant, and offers a single-chip solution to the most commonly used PC I/O peripherals.

System Hardware Monitoring provides minimum power consumption and maximum operating efficiency within the system environment. It integrates National's diode-based or thermistor-based Temperature Sensor (TMS) with National's Voltage Level Monitor (VLM) for full, PC system thermal control. The PC87366 monitors system voltages using 8-bit Analog to Digital (A/D) conversion with seven analog input channels and four internal measuring points.

The PC87366 also incorporates: Fan Speed Control and Monitor (FSCM) for three fans, extended wake-up support for a wide range of wake-up events, system design protection features, a Floppy Disk Controller (FDC), a Keyboard and Mouse Controller (KBC), a full IEEE 1284 Parallel Port, two enhanced Serial Ports (UARTs), one with Infrared (IR) support, ACCESS.bus® Interface (ACB), System Wake-Up Control (SWC), General-Purpose Input/Output (GPIO) support for 40 ports, Interrupt Serializer for Parallel IRQs and an enhanced WATCHDOG™ timer (WDT).

Outstanding Features

- System Hardware Monitoring including:
 - Diode-based or thermistor-based Temperature Sensor (TMS)
 - Voltage Level Monitor (VLM) with VID inputs
- MIDI interface compatible with MPU-401 UART mode
- Game port inputs for up to two joysticks
- Extended Wake-Up support, including legacy/ACPI power button support, direct power supply control in response to wake-up events, power-fail recovery
- Protection features, including chassis intrusion detection, GPIO lock and pin configuration lock
- Fan Speed Control and Monitor for three fans
- Serial IRQ support (15 options)
- Interrupt Serializer (11 Parallel IRQs to Serial IRQ)
- Bus interface, based on Intel's *LPC Interface Specification* Revision 1.0, September 29th, 1997
- ACCESS.bus interface, SMBus physical layer compatible
- 40 GPIO Ports (29 standard, including 15 with Assert IRQ/SMI/PWUREQs interrupts; 11 V_{SB}-powered)
- Blinking LEDs
- 128-pin PQFP Package

Block Diagram

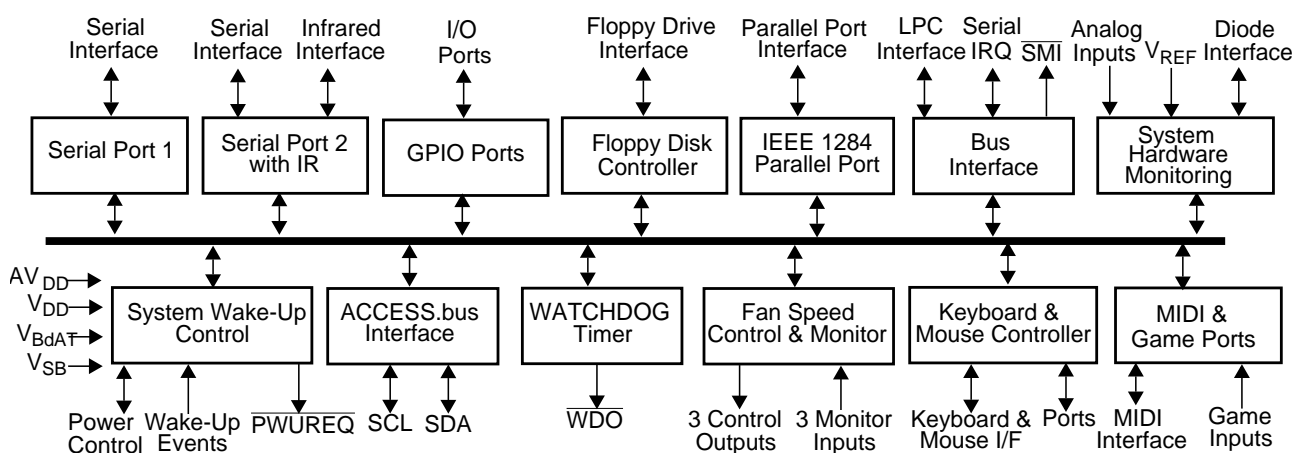

ACCESS.bus® is a registered trademark of Digital Equipment Corporation.
 I2C® is a registered trademark of Philips Corporation.
 IBM®, MicroChannel®, PC-AT® and PS/2® are registered trademarks of International Business Machines Corporation.
 Microsoft® and Windows® are registered trademarks of Microsoft Corporation.
 TRI-STATE® is a registered trademark of National Semiconductor Corporation.
 WATCHDOG™ is a trademark of National Semiconductor Corporation.
 SMBus® is a registered trademark of Intel Corporation.

Features

- Voltage Level Monitor (VLM)
 - Seven analog inputs that can support both positive and negative voltages
 - Four internal measuring points
 - Three thermistor-based temperature monitoring channels
 - Internal or external V_{REF}
 - VID inputs
 - Meets ACPI and DMI requirements for system voltage monitoring
- Temperature Sensor (TMS)
 - Up to two remote diode inputs
 - Environment temperature sensing via an internal diode
 - A/D analog channels provide thermal inputs to directly sense the temperature of remote diodes
 - Meets ACPI and DMI requirements for thermal management
 - Standby mode to minimize power consumption
- Extended Wake-Up
 - Legacy and ACPI power button support
 - Direct power supply control in response to wake-up events
 - Power-fail recovery
- Musical Instrument Digital Interface (MIDI) Port
 - Compatible with MPU-401 UART mode
 - 16-byte Receive and Transmit FIFOs
 - Loopback mode support
- Game Port
 - Full digital implementation
 - Supports up to two analog joysticks
- Protection
 - Chassis intrusion detection (CHASI, CHASO)
 - GPIO lock
 - Pin configuration lock
- 40 General-Purpose I/O (GPIO) Ports
 - 29 standard, with Assert IRQ/SMI/PWUREQ for 15 ports
 - 11 V_{SB} -powered
 - Programmable drive type for each output pin (open-drain, push-pull or output disable)
 - Programmable option for internal pull-up resistor on each input pin
 - Output lock option
 - Input debounce mechanism
- Fan Speed Control and Fan Speed Monitor (FSCM)
 - Supports different fan types
 - Speed monitoring for three fans
 - Digital filtering of the tachometer input signal
 - Alarm for fan slower than programmable threshold speed
 - Alarm for fan stop
 - Three speed control lines with Pulse Width Modulation (PWM)
 - Output signal in the range of 6 Hz to 93.75 KHz
 - Duty cycle resolution of 1/256
- LPC System Interface
 - Synchronous cycles, up to 33 MHz bus clock
 - 8-bit I/O cycles
 - Up to four DMA channels
 - 8-bit DMA cycles
 - Basic read, write and DMA bus cycles are 13 clock cycles long
- PC99 and ACPI Compliant
 - PnP Configuration Register structure
 - Flexible resource allocation for all logical devices
 - Relocatable base address
 - 15 IRQ routing options
 - 4 optional 8-bit DMA channels (where applicable)
- Floppy Disk Controller (FDC)
 - Programmable write protect
 - FM and MFM mode support
 - Enhanced mode command for three-mode Floppy Disk Drive (FDD) support
 - Perpendicular recording drive support for 2.88 MB
 - Burst and non-burst modes
 - Full support for IBM Tape Drive register (TDR) implementation of AT and PS/2 drive types
 - 16-byte FIFO
 - Software compatible with the PC8477, which contains a superset of the FDC functions in the microDP8473, the NEC microPD765A and the N82077
 - High-performance, digital separator
 - Standard 5.25" and 3.5" FDD support
- Parallel Port
 - Software or hardware control
 - Enhanced Parallel Port (EPP) compatible with new version EPP 1.9 and IEEE 1284 compliant
 - EPP support for version EPP 1.7 of the Xircom specification
 - EPP support as mode 4 of the Extended Capabilities Port (ECP)
 - IEEE 1284 compliant ECP, including level 2
 - Selection of internal pull-up or pull-down resistor for Paper End (PE) pin
 - PCI bus utilization reduction by supporting a demand DMA mode mechanism and a DMA fairness mechanism
 - Protection circuit that prevents damage to the parallel port when a printer connected to it powers up or is operated at high voltages, even if the device is in power-down
 - Output buffers that can sink and source 14 mA
- Serial Port 1 (UART1)
 - Software compatible with the 16550A and the 16450

Features (Continued)

- Shadow register support for write-only bit monitoring
- UART data rates up to 1.5 Mbaud
- Serial Port 2 with Infrared (UART2)
 - Software compatible with the 16550A and the 16450
 - Shadow register support for write-only bit monitoring
 - UART data rates up to 1.5 Mbaud
 - HP-SIR
 - ASK-IR option of SHARP-IR
 - DASK-IR option of SHARP-IR
 - Consumer Remote Control supports RC-5, RC-6, NEC, RCA and RECS 80
 - Non-standard DMA support – 1 or 2 channels
 - PnP dongle support
- Keyboard and Mouse Controller (KBC)
 - 8-bit microcontroller
 - Software compatible with the 8042AH and PC87911 microcontrollers
 - 2 KB custom-designed program ROM
 - 256 bytes RAM for data
 - Five programmable dedicated open-drain I/O lines
 - Asynchronous access to two data registers and one status register during normal operation
 - Support for both interrupt and polling
 - 93 instructions
 - 8-bit timer/counter
 - Support for binary and BCD arithmetic
 - Operation at 8 MHz, 12 MHz or 16 MHz (programmable option)
 - Can be customized by using the PC87323, which includes a RAM-based KBC as a development platform for KBC code
- ACCESS.bus Interface (ACB)
 - Serial interface compatible with SMBus physical layer
 - Compatible with Philips' I²C[®]
 - ACB master and slave
 - Supports polling and interrupt controlled operation
 - Optional internal pull-up on SDA and SCL pins
- WATCHDOG Timer (WDT)
 - Times out the system based on user-programmable time-out period
- System power-down capability for power saving
- User-defined trigger events to restart WATCHDOG
- Optional routing of WATCHDOG output on IRQ and/or SMI lines
- System Wake-Up Control (SWC)
 - Power-up request upon detection of Keyboard, Mouse, $\overline{RI1}$, $\overline{RI2}$, \overline{RING} activity and General-Purpose Input Events, as follows:
 - Preprogrammed Keyboard or Mouse sequence
 - External modem ring on serial port
 - Ring pulse or pulse train on the \overline{RING} input signal
 - Preprogrammed CEIR address in a preselected standard (NEC, RCA or RC-5)
 - General-Purpose Input Events
 - IRQs of internal logical devices
 - Optional routing of power-up request on IRQ, SMI and/or $\overline{PWBTOUT}$
 - Battery-backed event configuration
 - Programmable V_{SB} -powered output for blinking LEDs (LED1, LED2) control
- Clock Sources
 - 48 MHz clock input
 - LPC clock, up to 33 MHz
 - On-chip low frequency clock generator for wake-up
- Power Supplies
 - 3.3V supply operation
 - Main (V_{DD} and AV_{DD})
 - Standby (V_{SB})
 - Battery backup (V_{BAT})
 - All pins are 5V tolerant and back-drive protected, except LPC bus pins
- Strap Configuration
 - Base Address (BADDR) strap to determine the base address of the Index-Data register pair
 - Test strap to force the device into test mode (reserved for National Semiconductor use)
 - Power Supply and LED Configuration (PSLDC0,1) straps to determine the power supply control functions and the V_{SB} power-up defaults of LED2
 - Power Supply On Polarity (PSONPOL) strap to set PSON active state and output type

Datasheet Revision Record

Revision Date	Status	Comments
November 1998	Draft 0.3	Specification subject to change without notice; MIDI and Game Port information is incomplete
January 1999	Preliminary 1.0	Specification subject to change without notice; Power Supply Control and LED sections in Chapter 2 are incomplete

Item	Topic	Change/Correction	Location

Table of Contents

Datasheet Revision Record	4
.....	4
1.0 Signal/Pin Connection and Description	
1.1 CONNECTION DIAGRAM	16
1.2 BUFFER TYPES AND SIGNAL/PIN DIRECTORY	17
1.3 PIN MULTIPLEXING	22
1.4 DETAILED SIGNAL/PIN DESCRIPTIONS	24
1.4.1 ACCESS.bus Interface (ACB)	24
1.4.2 Bus Interface	24
1.4.3 Clock	24
1.4.4 Fan Speed Control and Monitor (FSCM)	24
1.4.5 Floppy Disk Controller (FDC)	25
1.4.6 Game Port	26
1.4.7 General-Purpose Input/Output (GPIO) Ports	26
1.4.8 Infrared (IR)	26
1.4.9 Keyboard and Mouse Controller (KBC)	27
1.4.10 Musical Instrument Digital Interface (MIDI) Port	27
1.4.11 Parallel Port	28
1.4.12 Power and Ground	28
1.4.13 Protection	29
1.4.14 Serial Port 1 and Serial Port 2	29
1.4.15 Strap Configuration	30
1.4.16 System Hardware Monitoring	30
1.4.17 System Wake-Up Control	31
1.4.18 WATCHDOG Timer (WDT)	31
1.5 INTERNAL PULL-UP AND PULL-DOWN RESISTORS	32
2.0 Device Architecture and Configuration	
2.1 OVERVIEW	34
2.2 CONFIGURATION STRUCTURE AND ACCESS	34
2.2.1 The Index-Data Register Pair	34
2.2.2 Banked Logical Device Registers Structure	36
2.2.3 Standard Logical Device Configuration Register Definitions	37
2.2.4 Standard Configuration Registers	39
2.2.5 Default Configuration Setup	40
2.2.6 Power States	40
2.2.7 Address Decoding	41
2.3 PROTECTION	41
2.3.1 Chassis Intrusion Detection	41
2.3.2 Pin Configuration Lock	41
2.3.3 GPIO Pin Function Lock	42
2.4 POWER SUPPLY CONTROL (PSC)	42
2.5 LED OPERATION AND STATES	44

(Continued)

2.6	POWER SUPPLY CONTROL AND LED CONFIGURATION	44
2.7	REGISTER TYPE ABBREVIATIONS	45
2.8	SUPERI/O CONFIGURATION REGISTERS	45
2.8.1	SuperI/O ID Register (SID)	46
2.8.2	SuperI/O Configuration 1 Register (SIOCF1)	46
2.8.3	SuperI/O Configuration 2 Register (SIOCF2)	47
2.8.4	SuperI/O Configuration 3 Register (SIOCF3)	48
2.8.5	SuperI/O Configuration 4 Register (SIOCF4)	49
2.8.6	SuperI/O Configuration 5 Register (SIOCF5)	50
2.8.7	SuperI/O Revision ID Register (SRID)	50
2.8.8	SuperI/O Configuration 8 Register (SIOCF8)	51
2.8.9	SuperI/O Configuration A Register (SIOCFA)	52
2.8.10	SuperI/O Configuration B Register (SIOCFB)	53
2.8.11	SuperI/O Configuration C Register (SIOCFC)	54
2.8.12	SuperI/O Configuration D Register (SIOCFD)	55
2.9	FLOPPY DISK CONTROLLER (FDC) CONFIGURATION	56
2.9.1	General Description	56
2.9.2	Logical Device 0 (FDC) Configuration	56
2.9.3	FDC Configuration Register	57
2.9.4	Drive ID Register	58
2.10	PARALLEL PORT CONFIGURATION	59
2.10.1	General Description	59
2.10.2	Logical Device 1 (PP) Configuration	60
2.10.3	Parallel Port Configuration Register	60
2.11	SERIAL PORT 2 CONFIGURATION	61
2.11.1	General Description	61
2.11.2	Logical Device 2 (SP2) Configuration	61
2.11.3	Serial Port 2 Configuration Register	61
2.12	SERIAL PORT 1 CONFIGURATION	62
2.12.1	Logical Device 3 (SP1) Configuration	62
2.12.2	Serial Port 1 Configuration Register	62
2.13	SYSTEM WAKE-UP CONTROL (SWC) CONFIGURATION	63
2.13.1	Logical Device 4 (SWC) Configuration	63
2.14	KEYBOARD AND MOUSE CONTROLLER (KBC) CONFIGURATION	64
2.14.1	General Description	64
2.14.2	Logical Devices 5 and 6 (Mouse and Keyboard) Configuration	65
2.14.3	KBC Configuration Register	66
2.15	GENERAL-PURPOSE INPUT/OUTPUT (GPIO) PORTS CONFIGURATION	67
2.15.1	General Description	67
2.15.2	Implementation	67
2.15.3	Logical Device 7 (GPIO) Configuration	68
2.15.4	GPIO Pin Select Register	69
2.15.5	GPIO Pin Configuration Register	70
2.15.6	GPIO Event Routing Register	71

(Continued)

2.16	ACCESS.BUS INTERFACE (ACB) CONFIGURATION	72
2.16.1	General Description	72
2.16.2	Logical Device 8 (ACB) Configuration	72
2.16.3	ACB Configuration Register	73
2.17	FAN SPEED CONTROL AND MONITOR (FSCM) CONFIGURATION	74
2.17.1	General Description	74
2.17.2	Logical Device 9 (FSCM) Configuration	74
2.17.3	Fan Speed Control and Monitor Configuration 1 Register	75
2.17.4	Fan Speed Control and Monitor Configuration 2 Register	76
2.17.5	Fan Speed Control OTS Configuration Register	76
2.18	WATCHDOG TIMER (WDT) CONFIGURATION	77
2.18.1	Logical Device 10 (WDT) Configuration	77
2.18.2	WATCHDOG Timer Configuration Register	77
2.19	GAME PORT (GMP) CONFIGURATION	78
2.19.1	Logical Device 11 (GMP) Configuration	78
2.19.2	Game Port Configuration Register	78
2.20	MIDI PORT (MIDI) CONFIGURATION	79
2.20.1	Logical Device 12 (MIDI) Configuration	79
2.20.2	MIDI Port Configuration Register	79
2.21	VOLTAGE LEVEL MONITOR (VLM) CONFIGURATION	80
2.21.1	Logical Device 13 (VLM) Configuration	80
2.22	TEMPERATURE SENSOR (TMS) CONFIGURATION	80
2.22.1	Logical Device 14 (TMS) Configuration	80

3.0 System Wake-Up Control (SWC)

3.1	OVERVIEW	81
3.2	FUNCTIONAL DESCRIPTION	82
3.3	EVENT DETECTION	83
3.3.1	Modem Ring	83
3.3.2	Telephone Ring	83
3.3.3	Keyboard and Mouse Activity	84
3.3.4	CEIR Address	84
3.3.5	Standby General-Purpose Input Events	84
3.3.6	GPIO-Triggered Events	84
3.3.7	Software Event	84
3.3.8	Module IRQ Wake-Up Event	85
3.4	SWC REGISTERS	85
3.4.1	SWC Register Map	85
3.4.2	Wake-Up Events Status Register 0 (WK_STS0)	88
3.4.3	Wake-Up Events Status Register (WK_STS1)	89
3.4.4	Wake-Up Events Enable Register (WK_EN0)	90
3.4.5	Wake-Up Events Enable Register 1 (WK_EN1)	91
3.4.6	Wake-Up Configuration Register (WK_CFG)	92
3.4.7	Wake-Up Events Routing to $\overline{\text{SMI}}$ Enable Register 0 (WK_SMIEN0)	93

(Continued)

3.4.8	Wake-Up Events Routing to $\overline{\text{SMI}}$ Enable Register 1 (WK_SMIEN1)	94
3.4.9	Wake-Up Events Routing to IRQ Enable Register 0 (WK_IRQEN0)	95
3.4.10	Wake-Up Events Routing to IRQ Enable Register 1 (WK_IRQEN1)	96
3.4.11	Wake-Up Extension 1 Enable Register 0 (WK_X1EN0)	97
3.4.12	Wake-Up Extension 1 Enable Register 1 (WK_X1EN1)	98
3.4.13	Wake-Up Extension 2 Enable Register 0 (WK_X2EN0)	99
3.4.14	Wake-Up Extension 2 Enable Register 1 (WK_X2EN1)	100
3.4.15	Wake-Up Extension 3 Enable Register 0 (WK_X3EN0)	101
3.4.16	Wake-Up Extension 3 Enable Register 1 (WK_X3EN1)	102
3.4.17	PS/2 Keyboard and Mouse Wake-Up Events	103
3.4.18	PS/2 Protocol Control Register (PS2CTL)	104
3.4.19	Keyboard Data Shift Register (KDSR)	104
3.4.20	Mouse Data Shift Register (MDSR)	105
3.4.21	PS/2 Keyboard Key Data Registers (PS2KEY0 - PS2KEY7)	105
3.4.22	CEIR Wake-Up Control Register (IRWCR)	106
3.4.23	CEIR Wake-Up Address Register (IRWAD)	107
3.4.24	CEIR Wake-Up Address Mask Register (IRWAM)	107
3.4.25	CEIR Address Shift Register (ADSR)	108
3.4.26	CEIR Wake-Up Range 0 Registers	108
3.4.27	CEIR Wake-Up Range 1 Registers	109
3.4.28	CEIR Wake-Up Range 2 Registers	109
3.4.29	CEIR Wake-Up Range 3 Registers	110
3.4.30	Standby General-Purpose I/O (SBGPIO) Register Overview	111
3.4.31	Standby GPIO Pin Select Register (SBGPSEL)	114
3.4.32	Standby GPIO Pin Configuration Register (SBGPCFG)	115
3.4.33	Standby GPIOE/GPIE Data Out Register 0 (SB_GPDO0)	117
3.4.34	Standby GPIOE/GPIE Data In Register 0 (SB_GPDI0)	117
3.4.35	Standby GPOS Data Out Register 1 (SB_GPDO1)	118
3.4.36	Standby GPIS Data In Register 1 (SB_GPDI1)	118
3.5	SWC REGISTER BITMAP	119

4.0 Fan Speed Control

4.1	OVERVIEW	123
4.2	FUNCTIONAL DESCRIPTION	123
4.3	FAN SPEED CONTROL REGISTERS	124
4.3.1	Fan Speed Control Register Map	124
4.3.2	Fan Speed Control Pre-Scale Register (FCPSR)	124
4.3.3	Fan Speed Control Duty Cycle Register (FCDCR)	125
4.4	FAN SPEED CONTROL BITMAP	125

5.0 Fan Speed Monitor

5.1	OVERVIEW	126
5.2	FUNCTIONAL DESCRIPTION	126
5.3	FAN SPEED MONITOR REGISTERS	127
5.3.1	Fan Speed Monitor Register Map	127

(Continued)

5.3.2	Fan Monitor Threshold Register (FMTHR)	128
5.3.3	Fan Monitor Speed Register (FMSPR)	128
5.3.4	Fan Monitor Control and Status Register (FMCSR)	128
5.4	FAN SPEED MONITOR BITMAP	129

6.0 General-Purpose Input/Output (GPIO) Port

6.1	OVERVIEW	130
6.2	BASIC FUNCTIONALITY	131
6.2.1	Configuration Options	131
6.2.2	Operation	131
6.3	EVENT HANDLING AND SYSTEM NOTIFICATION	132
6.3.1	Event Configuration	132
6.3.2	System Notification	132
6.4	GPIO PORT REGISTERS	133
6.4.1	GPIO Pin Configuration (GPCFG) Register	134
6.4.2	GPIO Pin Event Routing (GPEVR) Register	135
6.4.3	GPIO Port Runtime Register Map	135
6.4.4	GPIO Data Out Register (GPDO)	136
6.4.5	GPIO Data In Register (GPDI)	136
6.4.6	GPIO Event Enable Register (GPEVEN)	137
6.4.7	GPIO Event Status Register (GPEVST)	137

7.0 WATCHDOG Timer (WDT)

7.1	OVERVIEW	138
7.2	FUNCTIONAL DESCRIPTION	138
7.3	WATCHDOG TIMER REGISTERS	139
7.3.1	WATCHDOG Timer Register Map	139
7.3.2	WATCHDOG Timeout Register (WDTO)	139
7.3.3	WATCHDOG Mask Register (WDMSK)	140
7.3.4	WATCHDOG Status Register (WDST)	141
7.4	WATCHDOG TIMER REGISTER BITMAP	141

8.0 ACCESS.bus Interface (ACB)

8.1	OVERVIEW	142
8.2	FUNCTIONAL DESCRIPTION	142
8.2.1	Data Transactions	142
8.2.2	Start and Stop Conditions	142
8.2.3	Acknowledge (ACK) Cycle	143
8.2.4	Acknowledge after Every Byte Rule	144
8.2.5	Addressing Transfer Formats	144
8.2.6	Arbitration on the Bus	144
8.2.7	Master Mode	145
8.2.8	Slave Mode	147
8.2.9	Configuration	147

(Continued)

8.3	ACB REGISTERS	148
8.3.1	ACB Register Map	148
8.3.2	ACB Serial Data Register (ACBSDA)	148
8.3.3	ACB Status Register (ACBST)	149
8.3.4	ACB Control Status Register (ACBCST)	150
8.3.5	ACB Control Register 1 (ACBCTL1)	151
8.3.6	ACB Own Address Register (ACBADDR)	152
8.3.7	ACB Control Register 2 (ACBCTL2)	152
8.4	ACB REGISTER BITMAP	153

9.0 Game Port (GMP)

9.1	OVERVIEW	154
9.2	FUNCTIONAL DESCRIPTION	154
9.2.1	Game Device Axis Position Indication	154
9.2.2	Capturing the Position	155
9.2.3	Button Status Indication	156
9.2.4	Operation Modes	156
9.2.5	Operation Control	157
9.3	GAME PORT REGISTERS	158
9.3.1	Game Port Register Map	158
9.3.2	Game Port Control Register (GMPCTL)	159
9.3.3	Game Port Legacy Status Register (GMPNST)	160
9.3.4	Game Port Extended Status Register (GMPXST)	161
9.3.5	Game Port Interrupt Enable Register (GMPIEN)	162
9.3.6	Game Device A X-Axis Position Low Byte (GMPAXL)	163
9.3.7	Game Device A X-Axis Position High Byte (GMPAXH)	163
9.3.8	Game Device A Y-Axis Position Low Byte (GMPAYL)	163
9.3.9	Game Device A Y-Axis Position High Byte (GMPAYH)	163
9.3.10	Game Device B X-Axis Position Low Byte (GMPBXL)	164
9.3.11	Game Device B X-Axis Position High Byte (GMPBXH)	164
9.3.12	Game Device B Y-Axis Position Low Byte (GMPBYL)	164
9.3.13	Game Device B Y-Axis Position High Byte (GMPBYH)	164
9.3.14	Game Port Event Polarity Register (GMPEPOL)	165
9.4	GAME PORT BITMAP	166

10.0 Musical Instrument Digital Interface (MIDI) Port

10.1	OVERVIEW	167
10.2	FUNCTIONAL DESCRIPTION	167
10.2.1	Internal Bus Interface Unit	168
10.2.2	Port Control and Status Registers	168
10.2.3	Data Buffers and FIFOs	168
10.2.4	MIDI Communication Engine	168
10.2.5	MIDI Signals Routing Control Logic	169
10.2.6	Operation Modes	169
10.2.7	MIDI Port Status Flags	170

(Continued)

10.2.8	MIDI Port Interrupts	171
10.2.9	Enhanced MIDI Port Features	172
10.3	MIDI PORT REGISTERS	173
10.3.1	MIDI Port Register Map	173
10.3.2	MIDI Data In Register (MDI)	173
10.3.3	MIDI Data Out Register (MDO)	173
10.3.4	MIDI Status Register (MSTAT)	174
10.3.5	MIDI Command Register (MCOM)	174
10.3.6	MIDI Control Register (MCNTL)	175
10.4	MIDI PORT BITMAP	176

11.0 Voltage Level Monitor (VLM)

11.1	OVERVIEW	177
11.2	FUNCTIONAL DESCRIPTION	177
11.2.1	Voltage Measurement, Channels 0 through 10	178
11.2.2	Thermistor-Based Temperature Measurement, Channels 11 to 13	179
11.2.3	V_{OS} , V_{HIGH} and V_{LOW} Limits, OTS and ALERT Output, IRQ and SMI	179
11.2.4	Power-On Reset Default States	180
11.2.5	Standby Mode	180
11.3	ANALOG SUPPLY CONNECTION	180
11.3.1	Recommendations	180
11.3.2	Reference Voltage	181
11.4	REGISTER BANK OVERVIEW	181
11.5	VLM REGISTERS	182
11.5.1	VLM Register Map	182
11.5.2	Voltage Event Status Register 0 (VEVSTS0)	183
11.5.3	Voltage Event Status Register 1 (VEVSTS1)	183
11.5.4	Voltage Event to \overline{SMI} Register 0 (VEVSMI0)	184
11.5.5	Voltage Event to \overline{SMI} Register 1 (VEVSMI1)	185
11.5.6	Voltage Event to IRQ Register 0 (VEVIRQ0)	186
11.5.7	Voltage Event to IRQ Register 1 (VEVIRQ1)	186
11.5.8	Voltage ID Register (VID)	187
11.5.9	Voltage Conversion Rate Register (VCNVR)	188
11.5.10	VLM Configuration Register (VLMCFG)	189
11.5.11	VLM Bank Select Register (VLMBS)	189
11.5.12	Voltage Channel Configuration and Status Register (VCHCFST)	190
11.5.13	Read Channel Voltage Register (RDCHV)	191
11.5.14	Channel Voltage High Limit Register (CHVH)	191
11.5.15	Channel Voltage Low Limit Register (CHVL)	191
11.5.16	Overtemperature Shutdown Limit Register (OTSL)	191
11.6	VLM REGISTER BITMAP	192
11.6.1	VLM Control and Status Registers	192
11.6.2	VLM Channel Registers	192
11.7	USAGE HINTS	193

(Continued)

11.7.1	Calculating the Channel Delay	193
11.7.2	Measuring Out of Range Positive and Negative Voltages	194

12.0 Temperature Sensor (TMS)

12.1	OVERVIEW	195
12.2	FUNCTIONAL DESCRIPTION	195
12.2.1	Register Bank Overview	196
12.2.2	T _{OS} , T _{HIGH} and T _{LOW} Limits, OTS and ALERT Output, IRQ and SMI	196
12.2.3	ALERT Response Read Sequence	197
12.2.4	Power-On Reset Default States	197
12.2.5	Temperature Data Format	198
12.2.6	Standby Mode	198
12.2.7	Diode Fault Detection	198
12.3	TMS REGISTERS	199
12.3.1	TMS Register Map	199
12.3.2	Temperature Event Status Register (TEVSTS)	200
12.3.3	Temperature Event to SMI Register (TEVSMI)	201
12.3.4	Temperature Event to IRQ Register (TEVIRQ)	202
12.3.5	TMS Configuration Register (TMSCFG)	203
12.3.6	TMS Bank Select Register (TMSBS)	203
12.3.7	Temperature Channel Configuration and Status Register (TCHCFST)	204
12.3.8	Read Channel Temperature Register (RDCHT)	205
12.3.9	Channel Temperature High Limit Register (CHTH)	205
12.3.10	Channel Temperature Low Limit Register (CHTL)	205
12.3.11	Channel Overtemperature Limit Register (CHOTL)	205
12.4	TMS REGISTER BITMAP	206
12.4.1	TMS Control and Status Registers	206
12.4.2	TMS Channel Registers	206
12.5	USAGE HINTS	206
12.5.1	Remote Diode Selection	206
12.5.2	ADC Noise Filtering	207
12.5.3	PC Board Layout	207
12.5.4	Twisted Pair and Shielded Cables	209

13.0 Legacy Functional Blocks

13.1	KEYBOARD AND MOUSE CONTROLLER (KBC)	210
13.1.1	General Description	210
13.1.2	KBC Register Map	210
13.1.3	KBC Bitmap Summary	210
13.2	FLOPPY DISK CONTROLLER (FDC)	211
13.2.1	General Description	211
13.2.2	FDC Register Map	211
13.2.3	FDC Bitmap Summary	212
13.3	PARALLEL PORT	213
13.3.1	General Description	213

(Continued)

13.3.2	Parallel Port Register Map	213
13.3.3	Parallel Port Bitmap Summary	214
13.4	UART FUNCTIONALITY (SP1 AND SP2)	216
13.4.1	General Description	216
13.4.2	UART Mode Register Bank Overview	216
13.4.3	SP1 and SP2 Register Maps for UART Functionality	217
13.4.4	SP1 and SP2 Bitmap Summary for UART Functionality	219
13.5	IR FUNCTIONALITY (SP2)	221
13.5.1	General Description	221
13.5.2	IR Mode Register Bank Overview	221
13.5.3	SP2 Register Map for IR Functionality	222
13.5.4	SP2 Bitmap Summary for IR Functionality	223

14.0 Device Characteristics

14.1	GENERAL DC ELECTRICAL CHARACTERISTICS	225
14.1.1	Recommended Operating Conditions	225
14.1.2	Absolute Maximum Ratings	225
14.1.3	Capacitance	225
14.1.4	Power Consumption under Recommended Operating Conditions	226
14.2	DC CHARACTERISTICS OF PINS, BY I/O BUFFER TYPES	226
14.2.1	Input, CMOS Compatible	226
14.2.2	Input, PCI 3.3V	226
14.2.3	Input, SMBus Compatible	227
14.2.4	Input, Strap Pin	227
14.2.5	Input, TTL Compatible	227
14.2.6	Input, TTL Compatible with Schmitt Trigger	227
14.2.7	Output, PCI 3.3V	228
14.2.8	Output, Totem-Pole Buffer	228
14.2.9	Output, Open-Drain Buffer	228
14.2.10	Input, Analog	228
14.2.11	Input, Analog	228
14.2.12	Input, Analog	229
14.2.13	Output, Analog	229
14.2.14	Output, Analog	229
14.2.15	Exceptions	229
14.3	INTERNAL RESISTORS	230
14.3.1	Pull-Up Resistor	230
14.3.2	Pull-Down Resistor	230
14.4	ANALOG CHARACTERISTICS	230
14.4.1	VLM	230
14.4.2	TMS	230
14.5	AC ELECTRICAL CHARACTERISTICS	232
14.5.1	AC Test Conditions	232
14.5.2	Clock Timing	232
14.5.3	LCLK and LRESET	233

(Continued)

14.5.4	LPC and SERIRQ Signals	234
14.5.5	Serial Port, Sharp-IR, SIR and Consumer Remote Control Timing	235
14.5.6	Modem Control Timing	236
14.5.7	FDC Write Data Timing	236
14.5.8	FDC Drive Control Timing	237
14.5.9	FDC Read Data Timing	237
14.5.10	Standard Parallel Port Timing	238
14.5.11	Enhanced Parallel Port Timing	238
14.5.12	Extended Capabilities Port (ECP) Timing	239

(Continued)

1.0 Signal/Pin Connection and Description

1.1 CONNECTION DIAGRAM

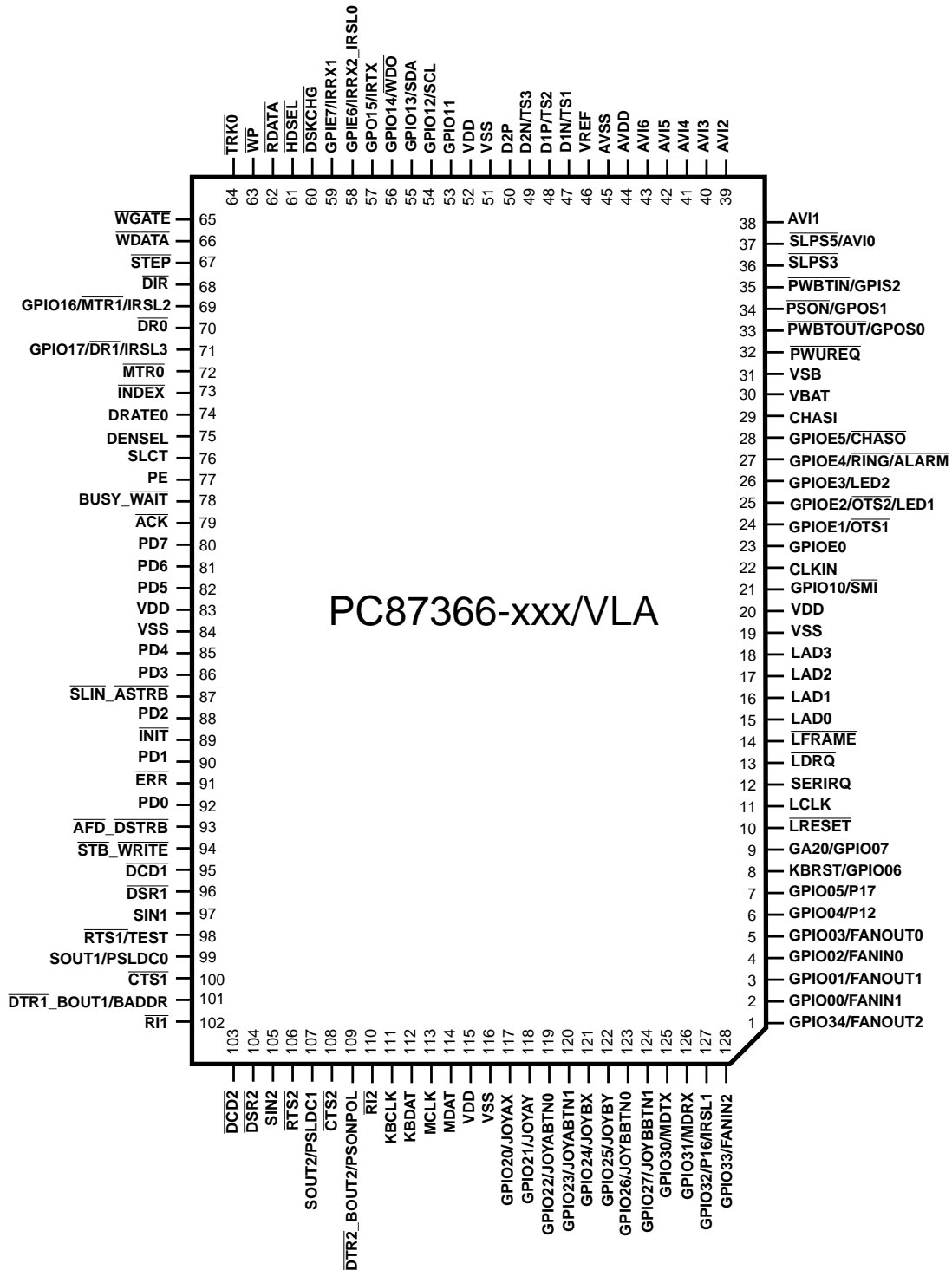

Plastic Quad Flatpack (PQFP), JEDEC

Order Number PC87366-xxx/VLA

See NS Package Number VLA128A

xxx = Three character identifier for National data, and keyboard ROM and/or customer identification code

1.0 Signal/Pin Connection and Description (Continued)

1.2 BUFFER TYPES AND SIGNAL/PIN DIRECTORY

Table 2 is an alphabetical list of all signals, cross-referenced to additional information for detailed functional descriptions, electrical DC characteristics, and pin multiplexing. The signal DC characteristics are denoted by a buffer type symbol, described briefly below and in further detail in Section 14.2. The pin multiplexing information refers to two different types of multiplexing:

- MUX - Multiplexed, denoted by a slash (/) between pins in the diagram in Section 1.1. Pins are shared between two different functions. Each function is associated with different board connectivity, and normally, the function selection is determined by the board design and cannot be changed dynamically. The multiplexing options must be configured by the BIOS upon power-up, in order to comply with the board implementation.
- MM - Multiple Mode, denoted by an underscore (_) between pins in the diagram in Section 1.1. Pins have two or more modes of operation within the same function. These modes are associated with the same external (board) connectivity. Mode selection may be controlled by the device driver, through the registers of the functional block, and do not require a special BIOS setup upon power-up. These pins are not considered multiplexed pins from the SuperI/O configuration perspective. The mode selection method (registers and bits) as well as the signal specification in each mode, are described within the functional description of the relevant functional block.

Table 1. Buffer Types

Symbol	Description
IN _{AN#}	Input, analog type number
IN _C	Input, CMOS compatible
IN _{PCI}	Input, PCI 3.3V
IN _{SM}	Input, SMBus compatible
IN _{STRP}	Input, Strap pin with weak pull-down during strap time
IN _T	Input, TTL compatible
IN _{TS}	Input, TTL compatible with Schmidt Trigger
IN _{ULR}	Input, with serial UL Resistor
O _{AN#}	Output, analog type number
O _{PCI}	Output, PCI 3.3V
O _{p/n}	Output, push-pull buffer that is capable of sourcing <i>p</i> mA and sinking <i>n</i> mA
OD _n	Output, open-drain output buffer that is capable of sinking <i>n</i> mA
PWR	Power pin
GND	Ground pin

Table 2. Signal/Pin Directory

Signal	Pin(s)	Functional Group		DC Characteristics		MUX
		Name	Section	Buffer Type	Section	
ACK	79	Parallel Port	1.4.11	IN _T	14.2.5	
AFD_DSTRB	93	Parallel Port	1.4.11	OD ₁₄ , O _{14/14}	14.2.9, 14.2.8	MM
ALARM	27	Hardware Monitoring	1.4.16	OD ₆	14.2.9	MUX
ASTRB	See SLIN_ASTRB					
AVI0	37	Hardware Monitoring	1.4.16	IN _{AN1}	14.2.10	MUX
AVI1-6	38-43	Hardware Monitoring	1.4.16	IN _{AN1}	14.2.10	
AV _{DD}	44	Power and Ground	1.4.12	PWR	N/A	

1.0 Signal/Pin Connection and Description (Continued)

Signal	Pin(s)	Functional Group		DC Characteristics		MUX
		Name	Section	Buffer Type	Section	
AV _{SS}	45	Power and Ground	1.4.12	AGND	N/A	
BADDR	101	Strap Configuration	1.4.15	IN _{STRP}	14.2.4	MUX
BOUT1	See $\overline{\text{DTR1_BOUT1}}$					
BOUT2	See $\overline{\text{DTR2_BOUT2}}$					
BUSY $\overline{\text{WAIT}}$	78	Parallel Port	1.4.11	IN _T	14.2.5	MM
CHASI	29	Protection	1.4.13	IN _C	14.2.1	
$\overline{\text{CHASO}}$	28	Protection	1.4.13	OD ₆	14.2.9	MUX
CLKIN	22	Clock	1.4.3	IN _T	14.2.5	
$\overline{\text{CTS1}}$	100	Serial Port 1	1.4.14	IN _{TS}	14.2.6	
$\overline{\text{CTS2}}$	108	Serial Port 2	1.4.14	IN _{TS}	14.2.6	
$\overline{\text{DCD1}}$	95	Serial Port 1	1.4.14	IN _{TS}	14.2.6	
$\overline{\text{DCD2}}$	103	Serial Port 2	1.4.14	IN _{TS}	14.2.6	
DENSEL	75	FDC	1.4.5	O _{2/12}	14.2.8	
$\overline{\text{DIR}}$	68	FDC	1.4.5	OD ₁₂ , O _{2/12}	14.2.9, 14.2.8	
D1N D2N	47 49	Hardware Monitoring	1.4.16	IN _{AN3}	14.2.12	
D1P D2P	48 50	Hardware Monitoring	1.4.16	IN _{AN2}	14.2.11	
$\overline{\text{DR0}}$	70	FDC	1.4.5	OD ₁₂ , O _{2/12}	14.2.9, 14.2.8	
$\overline{\text{DR1}}$	71	FDC	1.4.5	OD ₁₂ , O _{2/12}	14.2.9, 14.2.8	MUX
$\overline{\text{DRATE0}}$	74	FDC	1.4.5	O _{3/6}	14.2.8	
$\overline{\text{DSKCHG}}$	60	FDC	1.4.5	IN _T	14.2.5	
$\overline{\text{DSR1}}$	96	Serial Port 1	1.4.14	IN _{TS}	14.2.6	
$\overline{\text{DSR2}}$	104	Serial Port 2	1.4.14	IN _{TS}	14.2.6	
$\overline{\text{DSTRB}}$	See $\overline{\text{AFD_DSTRB}}$					
$\overline{\text{DTR1_BOUT1}}$	101	Serial Port 1	1.4.14	O _{3/6}	14.2.8	MUX, MM
$\overline{\text{DTR2_BOUT2}}$	109	Serial Port 2	1.4.14	O _{3/6}	14.2.8	MUX, MM
$\overline{\text{ERR}}$	91	Parallel Port	1.4.11	IN _T	14.2.5	
FANIN0	4	Fan Speed	1.4.4	IN _{TS}	14.2.6	MUX
FANIN1	2	Fan Speed	1.4.4	IN _{TS}	14.2.6	MUX
FANIN2	128	Fan Speed	1.4.4	IN _{TS}	14.2.6	MUX
FANOUT0	5	Fan Speed	1.4.4	O _{2/14}	14.2.8	MUX
FANOUT1	3	Fan Speed	1.4.4	O _{2/14}	14.2.8	MUX
FANOUT2	1	Fan Speed	1.4.4	O _{2/14}	14.2.8	MUX
GA20 (P21)	9	KBC	1.4.9	IN _T , OD ₂	14.2.5, 14.2.9	MUX

1.0 Signal/Pin Connection and Description (Continued)

Signal	Pin(s)	Functional Group		DC Characteristics		MUX
		Name	Section	Buffer Type	Section	
GPIE6-7	58-59	System Wake-Up	1.4.17	IN _{TS}	14.2.6	MUX
GPIO00-07	2-9	GPIO Port	1.4.7	IN _{TS} , OD ₆ , O _{3/6}	14.2.6, 14.2.9, 14.2.8	MUX
GPIO10 GPIO11-14 GPO15 GPIO16-17	21 53-56 57 69, 71	GPIO Port	1.4.7	IN _{TS} , OD ₆ , O _{3/6}	14.2.6, 14.2.9, 14.2.8	MUX
GPIO20-27	117-124	GPIO Port	1.4.7	IN _{TS} , OD ₆ , O _{3/6}	14.2.6, 14.2.9, 14.2.8	MUX
GPIO30-33 GPIO34	125-128 1	GPIO Port	1.4.7	IN _{TS} , OD ₆ , O _{3/6}	14.2.6, 14.2.9, 14.2.8	MUX
GPIOE0-1	23-24	System Wake-Up	1.4.17	IN _{TS} , OD ₆ , O _{3/6}	14.2.6, 14.2.9, 14.2.8	
GPIOE2-5	25-28	System Wake-Up	1.4.17	IN _{TS} , OD ₆ , O _{3/6}	14.2.6, 14.2.9, 14.2.8	MUX
GPIS2	35	System Wake-Up	1.4.17	IN _{TS}	14.2.6	MUX
GPOS0-1	33-34	System Wake-Up	1.4.17	OD ₆ , O _{3/6}	14.2.9, 14.2.8	MUX
$\overline{\text{HDSEL}}$	61	FDC	1.4.5	OD ₁₂ , O _{2/12}	14.2.9, 14.2.8	
$\overline{\text{INDEX}}$	73	FDC	1.4.5	IN _T	14.2.5	
$\overline{\text{INIT}}$	89	Parallel Port	1.4.11	OD ₁₄ , O _{14/14}	14.2.9, 14.2.8	
IRRX1	59	Infrared	1.4.8	IN _{TS}	14.2.6	MUX
IRRX2_IRSL0	58	Infrared	1.4.8	IN _{TS} , O _{3/6}	14.2.6, 14.2.8	MUX, MM
IRSL1	127	Infrared	1.4.8	IN _T , O _{3/6}	14.2.5, 14.2.8	MUX
IRSL2	69	Infrared	1.4.8	IN _T , O _{3/6}	14.2.5, 14.2.8	MUX
IRSL3	71	Infrared	1.4.8	IN _T	14.2.5	MUX
IRTX	57	Infrared	1.4.8	O _{6/12}	14.2.8	MUX
JOYABTN0	119	Game Port	1.4.6	IN _{TS}	14.2.6	MUX
JOYABTN1	120	Game Port	1.4.6	IN _{TS}	14.2.6	MUX
JOYAX	117	Game Port	1.4.6	IN _{TS} , OD ₁₂	14.2.6, 14.2.9	MUX
JOYAY	118	Game Port	1.4.6	IN _{TS} , OD ₁₂	14.2.6, 14.2.9	MUX
JOYBBTN0	123	Game Port	1.4.6	IN _{TS}	14.2.6	MUX
JOYBBTN1	124	Game Port	1.4.6	IN _{TS}	14.2.6	MUX
JOYBX	121	Game Port	1.4.6	IN _{TS} , OD ₁₂	14.2.6, 14.2.9	MUX
JOYBY	122	Game Port	1.4.6	IN _{TS} , OD ₁₂	14.2.6, 14.2.9	MUX
KBCLK	111	KBC	1.4.9	IN _{TS} , OD ₁₄	14.2.6, 14.2.9	
KBDAT	112	KBC	1.4.9	IN _{TS} , OD ₁₄	14.2.6, 14.2.9	
KBRST (P20)	8	KBC	1.4.9	IN _{TS} , OD ₂	14.2.6, 14.2.9	MUX
LAD0-3	15-18	Bus Interface	1.4.2	IN _{PCI} , O _{PCI}	14.2.2, 14.2.7	
LED1, LED2	25, 26	System Wake-Up	1.4.17	O _{12/12}	14.2.8	MUX
LCLK	11	Bus Interface	1.4.2	IN _{PCI}	14.2.2	

1.0 Signal/Pin Connection and Description (Continued)

Signal	Pin(s)	Functional Group		DC Characteristics		MUX
		Name	Section	Buffer Type	Section	
LDRQ	13	Bus Interface	1.4.2	O _{PCI}	14.2.7	
LFRAME	14	Bus Interface	1.4.2	IN _{PCI}	14.2.2	
LRESET	10	Bus Interface	1.4.2	IN _{PCI}	14.2.2	
MCLK	13	KBC	1.4.9	IN _{TS} , OD ₁₄	14.2.6, 14.2.9	
MDAT	114	KBC	1.4.9	IN _{TS} , OD ₁₄	14.2.6, 14.2.9	
MDRX	126	MIDI Port	1.4.10	IN _{TS}	14.2.6	MUX
MDTX	125	MIDI Port	1.4.10	O _{3/6}	14.2.8	MUX
MTR0	72	FDC	1.4.5	OD ₁₂ , O _{2/12}	14.2.9, 14.2.8	
MTR1	69	FDC	1.4.5	OD ₁₂ , O _{2/12}	14.2.9, 14.2.8	MUX
OTS1 OTS2	24 25	Hardware Monitoring	1.4.16	OD ₆	14.2.9	MUX
P12, P16, P17	6,127, 7	KBC	1.4.9	IN _T , OD ₂	14.2.5, 14.2.9	MUX
PD7-5 PD4-3, PD2, PD1 PD0	80-82 85-86 88, 90 92	Parallel Port	1.4.11	IN _T , OD ₁₄ , O _{14/14}	14.2.5, 14.2.9, 14.2.8	
PE	77	Parallel Port	1.4.11	IN _T	14.2.5	
PIRQ3-7 PIRQ9-12 PIRQ14-15	117-121 122-125 126-127	Bus Interface	1.4.2	IN _{TS}	14.2.6	MUX
PSLDC0	99	Strap Configuration	1.4.15	IN _{STRP}	14.2.4	MUX
PSLDC1	107	Strap Configuration	1.4.15	IN _{STRP}	14.2.4	MUX
PSON	34	System Wake-Up	1.4.17	OD ₁₂ , O _{4/4}	14.2.9, 14.2.8	MUX
PSONPOL	109	Strap Configuration	1.4.15	IN _{STRP}	14.2.4	MUX
PWBTIN	35	System Wake-Up	1.4.17	IN _{TS}	14.2.6	MUX
PWBTOU	33	System Wake-Up	1.4.17	OD ₁₂	14.2.9	MUX
PWUREQ	32	System Wake-Up	1.4.17	OD ₆	14.2.9	
RDATA	62	FDC	1.4.5	IN _T	14.2.5	
RI1	102	Serial Port 1	1.4.14	IN _{TS}	14.2.6	
RI2	110	Serial Port 2	1.4.14	IN _{TS}	14.2.6	
RING	27	System Wake-Up	1.4.17	IN _{TS}	14.2.6	MUX
RTS1	98	Serial Port 1	1.4.14	O _{3/6}	14.2.8	MUX
RTS2	106	Serial Port 2	1.4.14	O _{3/6}	14.2.8	
SCL	54	ACB	1.4.1	IN _T , OD ₆ , O _{3/6}	14.2.5, 14.2.9, 14.2.8	MUX
SDA	55	ACB	1.4.1	IN _T , OD ₆ , O _{3/6}	14.2.5, 14.2.9, 14.2.8	MUX
SERIRQ	12	Bus Interface	1.4.2	IN _{PCI} , O _{PCI}	14.2.2, 14.2.7	
SIN1	97	Serial Port 1	1.4.14	IN _{TS}	14.2.6	

1.0 Signal/Pin Connection and Description (Continued)

Signal	Pin(s)	Functional Group		DC Characteristics		MUX
		Name	Section	Buffer Type	Section	
SIN2	105	Serial Port 2	1.4.14	IN _{TS}	14.2.6	
SLCT	76	Parallel Port	1.4.11	IN _T	14.2.5	
SLIN_ASTRB	87	Parallel Port	1.4.11	OD ₁₄ , O _{14/14}	14.2.9, 14.2.8	MM
SLPS3,5	36,37	System Wake-Up	1.4.17	IN _{TS}	14.2.6	MUX (SLPS3)
SMI	21	Bus Interface	1.4.2	OD ₁₂	14.2.9	MUX
SOUT1	99	Serial Port 1	1.4.14	O _{3/6}	14.2.8	MUX
SOUT2	107	Serial Port 2	1.4.14	O _{3/6}	14.2.8	MUX
STEP	67	FDC	1.4.5	OD ₁₂ , O _{2/12}	14.2.9, 14.2.8	
STB_WRITE	94	Parallel Port	1.4.11	OD ₁₄ , O _{14/14}	14.2.9, 14.2.8	MM
TEST	98	Strap Configuration	1.4.15	IN _{STRP}	14.2.4	MUX
TRK0	64	FDC	1.4.5	IN _T	14.2.5	
TS1-3	47-49	VLM	1.4.16	IN _{AN1}	14.2.10	MUX
V _{BAT}	30	Power and Ground	1.4.12	IN _{ULR}	N/A	
V _{DD}	20, 52, 83, 115	Power and Ground	1.4.12	PWR	N/A	
V _{REF}	46	Hardware Monitoring	1.4.16	IN _{AN2} , O _{AN1}	14.2.11, 14.2.13	
V _{SB}	31	Power and Ground	1.4.12	PWR	N/A	
V _{SS}	19, 51, 84, 116	Power and Ground	1.4.12	GND	N/A	
WAIT	See BUSY_WAIT					
WDATA	66	FDC	1.4.5	OD ₁₂ , O _{2/12}	14.2.9, 14.2.8	
WDO	56	WATCHDOG	1.4.18	OD ₆ , O _{3/6}	14.2.9, 14.2.8	MUX
WGATE	65	FDC	1.4.5	OD ₁₂ , O _{2/12}	14.2.9, 14.2.8	
WP	63	FDC	1.4.5	IN _T	14.2.5	
WRITE	See STB_WRITE					

1.0 Signal/Pin Connection and Description (Continued)

1.3 PIN MULTIPLEXING

The multiplexing options and the associated setup configuration for all pins are described in Table 3. A multiplexing option can be chosen on one pin only per group.

Table 3. Pin Multiplexing Configuration

Pin(s)	Default			Alternate		
	Signal	I/O	Configuration	Signal	I/O	Configuration
1	GPIO34	I/O	SIOCF2, Bits 1-0 = 00	FANOUT2	O	SIOCF2, Bits 1-0 = 01
				CHLOCK	O	SIOCF2, Bits 1-0 = 10
2	GPIO00	I/O	SIOCF2, Bit 2 = 0	FANIN1	I	SIOCF2, Bit 2 = 1
3	GPIO01	I/O	SIOCF2, Bit 3 = 0	FANOUT1	O	SIOCF2, Bit 3 = 1
4	GPIO02	I/O	SIOCF2, Bit 4 = 0	FANIN0	I	SIOCF2, Bit 4 = 1
5	GPIO03	I/O	SIOCF2, Bit 5 = 0	FANOUT0	O	SIOCF2, Bit 5 = 1
6	GPIO04	I/O	SIOCF2, Bit 6 = 0	P12	I/O	SIOCF2, Bit 6 = 1
7	GPIO05	I/O	SIOCF2, Bit 7 = 0	P17	I/O	SIOCF2, Bit 7 = 1
8	KBRST (P20)		SIOCF3, Bit 0 = 1	GPIO06	I/O	SIOCF3, Bit 0 = 0
9	GA20 (P21)		SIOCF3, Bit 1 = 1	GPIO07	I/O	SIOCF3, Bit 1 = 0
21	GPIO10	I/O	SIOCF3, Bit 2 = 0	SMI	O	SIOCF3, Bit 2 = 1
24	GPIOE1	I/O	SIOCFA, Bit 0 = 0	OTS1	O	SIOCFA, Bit 0 = 1
25	GPIOE2	I/O	SIOCFA, Bits 2-1 = 00 ^{Note 1.}	LED1	O	SIOCFA, Bits 2-1 = 01
				OTS2	O	SIOCFA, Bits 2-1 = 10
26	GPIOE3	I/O	SIOCFA, Bit 3 = 0 ^{Note 1.}	LED2	O	SIOCFA, Bit 3 = 1
27	GPIOE4	I/O	SIOCFA, Bits 5-4 = 00	RING	I	SIOCFA, Bits 5-4 = 01
				ALARM	O	SIOCFA, Bits 5-4 = 10
28	GPIOE5	I/O	SIOCFA, Bit 6 = 0	CHASO	O	SIOCFA, Bit 6 = 1
33-35, 37	PWBTOUT PSON PWBTIN SLPS5	O O I I	SIOCFA, Bit 7 = 0 ^{Note 1.}	GPOS0 GPOS1 GPIS2 AVI0	0 0 I I	SIOCFA, Bit 7 = 1 ^{Note 1.}
47	D1N	I	SIOCFB, Bit 6 = 0	TS1	I	SIOCFB, Bit 6 = 1
48	D1P	O	SIOCFB, Bit 6 = 0	TS2	I	SIOCFB, Bit 6 = 1
49	D2N	I	SIOCFB, Bit 6 = 0	TS3	I	SIOCFB, Bit 6 = 1
54	GPIO12	I/O	SIOCF3, Bit 5 = 0	SCL	I/O	SIOCF3, Bit 5 = 1
55	GPIO13	I/O	SIOCF3, Bit 5 = 0	SDA	I/O	SIOCF3, Bit 5 = 1
56	GPIO14	I/O	SIOCF3, Bit 6 = 0	WDO	O	SIOCF3, Bit 6 = 1
57	GPO15	O	SIOCF3, Bit 7 = 0	IRTX	O	SIOCF3, Bit 7 = 1
58	GPIE6	I	SIOCFB, Bit 0 = 0	IRRX2_IRSL0	I/O	SIOCFB, Bit 0 = 1
59	GPIE7	I	SIOCFB, Bit 1 = 0	IRRX1	I	SIOCFB, Bit 1 = 1
69	GPIO16	I/O	SIOCFA, Bits 1-0 = 00	MTR1	O	SIOCFA, Bits 1-0 = 01
				IRSL2	I/O	SIOCFA, Bits 1-0 = 10
71	GPIO17	I/O	SIOCFA, Bits 3-2 = 00	DR1	O	SIOCFA, Bits 3-2 = 01
				IRSL3	I	SIOCFA, Bits 3-2 = 10
117	GPIO20	I/O	SIOCFA, Bit 4 = 0	JOYAX	I/O	SIOCFA, Bit 4 = 1
118	GPIO21	I/O	SIOCFA, Bit 4 = 0	JOYAY	I/O	SIOCFA, Bit 4 = 1

1.0 Signal/Pin Connection and Description (Continued)

Pin(s)	Default			Alternate		
	Signal	I/O	Configuration	Signal	I/O	Configuration
119	GPIO22	I/O	SIOCF4, Bit 4 = 0	JOYABTN0	I	SIOCF4, Bit 4 = 1
120	GPIO23	I/O	SIOCF4, Bit 4 = 0	JOYABTN1	I	SIOCF4, Bit 4 = 1
121	GPIO24	I/O	SIOCF4, Bit 4 = 0	JOYBX	I/O	SIOCF4, Bit 4 = 1
122	GPIO25	I/O	SIOCF4, Bit 4 = 0	JOYBY	I/O	SIOCF4, Bit 4 = 1
123	GPIO26	I/O	SIOCF4, Bit 4 = 0	JOYBBTN0	I	SIOCF4, Bit 4 = 1
124	GPIO27	I/O	SIOCF4, Bit 4 = 0	JOYBBTN1	I	SIOCF4, Bit 4 = 1
125	GPIO30	I/O	SIOCF4, Bit 5 = 0	MDTX	O	SIOCF4, Bit 5 = 1
126	GPIO31	I/O	SIOCF4, Bit 5 = 0	MDRX	I	SIOCF4, Bit 5 = 1
127	GPIO32	I/O	SIOCF4, Bits 7,6 = 00	P16	I/O	SIOCF4, Bits 7,6 = 01
				IRSL1	I/O	SIOCF4, Bits 7,6 = 10
128	GPIO33	I/O	SIOCF5, Bits 1-0 = 00	FANIN2	I	SIOCF5, Bits 1-0 = 10

Note 1. The signal selected on each pin is determined during V_{SB} power-up by the PSLDC0,1 straps.

1.0 Signal/Pin Connection and Description (Continued)

1.4 DETAILED SIGNAL/PIN DESCRIPTIONS

This section describes all signals, organized in functional groups.

1.4.1 ACCESS.bus Interface (ACB)

Signal	Pin(s)	I/O	Buffer Type	Power Well	Description
SCL	54	I/O	IN _{SM} /OD ₆	V _{DD}	ACCESS.bus Clock Signal. An internal pull-up is optional, depending upon the ACCESS.bus configuration register.
SDA	55	I/O	IN _{SM} /OD ₆	V _{DD}	ACCESS.bus Data Signal. An internal pull-up is optional, depending upon the ACCESS.bus configuration register.

1.4.2 Bus Interface

Signal	Pin(s)	I/O	Buffer Type	Power Well	Description
LAD0-3	15-18	I/O	IN _{PCI} /O _{PCI}	V _{DD}	LPC Address-Data. Multiplexed command, address bi-directional data and cycle status.
LCLK	11	I	IN _{PCI}	V _{DD}	LPC Clock. Practically the PCI clock (up to 33 MHz)
LDRQ	13	O	O _{PCI}	V _{DD}	LPC DMA Request. Encoded DMA request for LPC I/F.
LFRAME	14	I	IN _{PCI}	V _{DD}	LPC Frame. Low pulse indicates the beginning of new LPC cycle or termination of a broken cycle.
LRESET	10	I	IN _{PCI}	V _{DD}	LPC Reset. Practically the PCI system reset.
SERIRQ	12	I/O	IN _{PCI} /O _{PCI}	V _{DD}	Serial IRQ. The interrupt requests are serialized over a single pin, where each internal IRQ signal is delivered during a designated time slot.
SMI	21	OD	OD ₁₂	V _{DD}	System Management Interrupt

1.4.3 Clock

Signal	Pin(s)	I/O	Buffer Type	Power Well	Description
CLKIN	22	I	IN _T	V _{DD}	Clock In. 48 MHz clock input.

1.4.4 Fan Speed Control and Monitor (FSCM)

Signal	Pin(s)	I/O	Buffer Type	Power Well	Description
FANIN0 FANIN1 FANIN2	4 2 128	I	IN _{TS}	V _{DD}	Fan Inputs. Used to feed the fan's tachometer pulse to the Fan Speed Monitor. The rising edge indicates the completion of a half (or full) revolution of the fan.
FANOUT0 FANOUT1 FANOUT2	5 3 1	O	O _{2/14}	V _{DD}	Fan Outputs. Pulse Width Modulation (PWM) signals, used to control the speed of cooling fans by controlling the voltage supplied to the fan's motor.

1.0 Signal/Pin Connection and Description (Continued)

1.4.5 Floppy Disk Controller (FDC)

Signal	Pin(s)	I/O	Buffer Type	Power Well	Description
DENSEL	75	O	O _{2/12}	V _{DD}	Density Select. Indicates that a high FDC density data rate (500 Kbps or 1 Mbps) or a low density data rate (250 or 300 Kbps) is selected. DENSEL polarity is controlled by bit 5 of the FDC Configuration Register.
$\overline{\text{DIR}}$	68	O	OD ₁₂ , O _{2/12}	V _{DD}	Direction. Determines the direction of the Floppy Disk Drive (FDD) head movement (active = step in, inactive = step out) during a seek operation. During reads or writes, $\overline{\text{DIR}}$ is inactive.
$\overline{\text{DR0}}$	70	O	OD ₁₂ , O _{2/12}	V _{DD}	Drive Select 0. Decoded drive select output signal. $\overline{\text{DR0}}$ is controlled by bit 0 of the Digital Output Register (DOR).
$\overline{\text{DR1}}$	71	O	OD ₁₂ , O _{2/12}	V _{DD}	Drive Select 1. Decoded drive select output signal. $\overline{\text{DR1}}$ is controlled by bit 1 of the Digital Output Register (DOR).
DRATE0	74	O	O _{3/6}	V _{DD}	Data Rate 0. Reflects the value of bit 0 of the Configuration Control Register (CCR) or the Data Rate Select Register (DSR), whichever was written to last. Output from the pin is push-pull buffered.
$\overline{\text{DSKCHG}}$	60	I	IN _T	V _{DD}	Disk Change. Indicates if the drive door has been opened. The state of this pin is stored in the Digital Input Register (DIR). This pin can also be configured as the RGATE data separator diagnostic input signal via the MODE command.
$\overline{\text{HDSEL}}$	61	O	OD ₁₂ , O _{2/12}	V _{DD}	Head Select. Determines which side of the FDD is accessed. Active low selects side 1, inactive selects side 0.
$\overline{\text{INDEX}}$	73	I	IN _T	V _{DD}	Index. Indicates the beginning of an FDD track.
$\overline{\text{MTR0}}$	72	O	OD ₁₂ , O _{2/12}	V _{DD}	Motor Select 0. Active low, motor enable line for drives 0, controlled by bits D7-4 of the Digital Output Register (DOR).
$\overline{\text{MTR1}}$	69	O	OD ₁₂ , O _{2/12}	V _{DD}	Motor Select 1. Active low, motor enable lines for drives 1, controlled by bits D7-4 of the Digital Output Register (DOR).
$\overline{\text{RDATA}}$	62	I	IN _T	V _{DD}	Read Data. Raw serial input data stream read from the FDD.
$\overline{\text{STEP}}$	67	O	OD ₁₂ , O _{2/12}	V _{DD}	Step. Issues pulses to the disk drive at a software programmable rate to move the head during a seek operation.
$\overline{\text{TRK0}}$	64	I	IN _T	V _{DD}	Track 0. Indicates to the controller that the head of the selected floppy disk drive is at track 0.
$\overline{\text{WDATA}}$	66	O	OD ₁₂ , O _{2/12}	V _{DD}	Write Data. Carries out the pre-compensated serial data that is written to the floppy disk drive. Pre-compensation is software selectable.
$\overline{\text{WGATE}}$	65	O	OD ₁₂ , O _{2/12}	V _{DD}	Write Gate. Enables the write circuitry of the selected disk drive. $\overline{\text{WGATE}}$ is designed to prevent glitches during power up and power down. This prevents writing to the disk when power is cycled.
$\overline{\text{WP}}$	63	I	IN _T	V _{DD}	Write Protected. Indicates that the disk in the selected drive is write protected. A software programmable configuration bit (FDC configuration at Index F0h, Logical Device 0) can force an active write-protect indication to the FDC, regardless of the status of this pin.

1.0 Signal/Pin Connection and Description (Continued)

1.4.6 Game Port

Signal	Pin(s)	I/O	Buffer Type	Power Well	Description
JOYAX	117	I/O	IN _{TS} /OD ₁₂	V _{DD}	Joystick A X-Axis. Indicates X-axis position of joystick A.
JOYAY	118	I/O	IN _{TS} /OD ₁₂	V _{DD}	Joystick A Y-Axis. Indicates Y-axis position of joystick A.
JOYABTN0	119	I	IN _{TS}	V _{DD}	Joystick A Button 0. Indicates button 0 status of joystick A.
JOYABTN1	120	I	IN _{TS}	V _{DD}	Joystick A Button 1. Indicates button 1 status of joystick A.
JOYBX	121	I/O	IN _{TS} /OD ₁₂	V _{DD}	Joystick B X-Axis. Indicates X-axis position of joystick B.
JOYBY	122	I/O	IN _{TS} /OD ₁₂	V _{DD}	Joystick BY-Axis. Indicates Y-axis position of joystick B.
JOYBBTN0	123	I	IN _{TS}	V _{DD}	Joystick B Button 0. Indicates button 0 status of joystick B.
JOYBBTN1	124	I	IN _{TS}	V _{DD}	Joystick B Button 1. Indicates button 1 status of joystick B.

1.4.7 General-Purpose Input/Output (GPIO) Ports

Signal	Pin/s	I/O	Buffer Type	Power Well	Description
GPIO00-07	2-9	I/O	IN _{TS} / OD ₆ , O _{3/6}	V _{DD}	General-Purpose I/O Port 0, bits 0-7. Each pin is configured independently as input or I/O, with or without static pull-up, and with either open-drain or push-pull output type. The port support interrupt assertion and each pin can be enabled or masked as an interrupt source.
GPIO10 GPIO11-14 GPO15 GPIO16-17	21 53-56 57 69, 71	I/O	IN _{TS} / OD ₆ , O _{3/6}	V _{DD}	General-Purpose I/O Port 1, bits 0-7. Same as Port 0. Bit 5 is output only with low output as default.
GPIO20-27	117-124	I/O	IN _{TS} / OD ₆ , O _{3/6}	V _{DD}	General-Purpose I/O Port 2, bits 0-7. Similar to port 0, but without the interrupt assertion capability.
GPIO30-33 GPIO34	125-128 1	I/O	IN _{TS} / OD ₆ , O _{3/6}	V _{DD}	General-Purpose I/O Port 3, bits 0-4. Similar to port 0, but without the interrupt assertion capability. Bits 5, 6 and 7 are not implemented.

1.4.8 Infrared (IR)

Signal	Pin/s	I/O	Buffer Type	Power Well	Description
IRRX1	59	I	IN _{TS}	V _{DD} , V _{SB}	IR Receive 1. Primary input to receive serial data from the IR transceiver. Monitored during power-off for wake-up event detection.
IRRX2_IRSL0	58	I/O	IN _{TS} /O _{3/6}	V _{DD} , V _{SB}	IRRX2 - IR Receive 2. Auxiliary IR receiver input to support a second transceiver. Monitored during power-off for wake-up event detection.
IRSL1	127	I/O	IN _T /O _{3/6}	V _{DD}	
IRSL2	69	I/O	IN _T /O _{3/6}	V _{DD}	IRSL3-0 IR Select. Output are used to control the IR transceivers. Input for PnP identification of plug-in IR transceiver (dongle). After reset, the dual-function IRSLX pins wake up in input mode. After the ID is read by the IR driver, they may be put into output mode. The output mode is controlled by Serial Port 2.
IRSL3	71	I	IN _T	V _{DD}	
IRTX	57	O	O _{6/12}	V _{DD}	IR Transmit. IR serial output data.

1.0 Signal/Pin Connection and Description (Continued)

1.4.9 Keyboard and Mouse Controller (KBC)

Signal	Pin/s	I/O	Buffer Type	Power Well	Description
GA20	9	I/O	IN _T /OD ₂	V _{DD}	Gate A20. KBC gate A20 (P21) output.
KBCLK	111	I/O	IN _{TS} /OD ₁₄	V _{DD} , V _{SB}	Keyboard Clock. Transfers the keyboard clock between the SuperI/O chip and the external keyboard using the PS/2 protocol. This pin is driven by the internal, inverted KBC P26 signal, and is connected internally to the T0 signal of the KBC. External pull-up resistor to 5V is required (for PS/2 compliance). The pin is monitored for wake-up event detection. To enable the activity during power off, it must be pulled up to Keyboard and Mouse standby voltage.
KBDAT	112	I/O	IN _{TS} /OD ₁₄	V _{DD} , V _{SB}	Keyboard Data. Transfers the keyboard data between the SuperI/O chip and the external keyboard using the PS/2 protocol. This pin is driven by the internal, inverted KBC P27 signal, and is connected internally to KBC P10. External pull-up resistor to 5V is required (for PS/2 compliance). The pin is monitored for wake-up event detection. To enable the activity during power off, it must be pulled up to Keyboard and Mouse standby voltage.
KBRST	8	I/O	IN _T /OD ₂	V _{DD}	KBD Reset. Keyboard Reset (P20) output.
MCLK	113	I/O	IN _{TS} /OD ₁₄	V _{DD} , V _{SB}	Mouse Clock. Transfers the mouse clock between the SuperI/O chip and the external keyboard using the PS/2 protocol. This pin is driven by the internal, inverted KBC P23 signal, and is connected internally to KBC T1. External pull-up resistor to 5V is required (for PS/2 compliance). The pin is monitored for wake-up event detection. To enable the activity during power off, it must be pulled up to Keyboard and Mouse standby voltage.
MDAT	114	I/O	IN _{TS} /OD ₁₄	V _{DD} , V _{SB}	Mouse Data. Transfers the mouse data between the SuperI/O chip and the external keyboard using the PS/2 protocol. This pin is driven by the internal, inverted KBC P22 signal, and is connected internally to KBC P11. External pull-up resistor to 5V is required (for PS/2 compliance). The pin is monitored for wake-up event detection. To enable the activity during power off, it must be pulled up to Keyboard and Mouse standby voltage.
P12, P16, P17	6,127, 7	I/O	IN _T /OD ₂	V _{DD}	I/O Port. KBC open-drain signal for general-purpose input and output, controlled by KBC firmware.

1.4.10 Musical Instrument Digital Interface (MIDI) Port

Signal	Pin(s)	I/O	Buffer Type	Power Well	Description
MDTX	125	O	O _{3/6}	V _{DD}	MIDI Transmit. MIDI serial data output.
MDRX	126	I	IN _{TS}	V _{DD}	MIDI Receive. MIDI serial data input.

1.0 Signal/Pin Connection and Description (Continued)

1.4.11 Parallel Port

Signal	Pin/s	I/O	Buffer Type	Power Well	Description
$\overline{\text{ACK}}$	79	I	IN _T	V _{DD}	Acknowledge. Pulsed low by the printer to indicate that it has received data from the Parallel Port.
$\overline{\text{AFD_DSTRB}}$	93	O	OD ₁₄ , O _{14/14}	V _{DD}	AFD - Automatic Feed. When low, instructs the printer to automatically feed a line after printing each line. This pin is in TRI-STATE after a 0 is loaded into the corresponding control register bit. An external 4.7 K Ω pull-up resistor should be attached to this pin. DSTRB - Data Strobe (EPP). Active low, used in EPP mode to denote a data cycle. When the cycle is aborted, $\overline{\text{DSTRB}}$ becomes inactive (high).
$\overline{\text{BUSY_WAIT}}$	78	I	IN _T	V _{DD}	Busy. Set high by the printer when it cannot accept another character. Wait. In EPP mode, the Parallel Port device uses this active low signal to extend its access cycle.
$\overline{\text{ERR}}$	91	I	IN _T	V _{DD}	Error. Set active low by the printer when it detects an error.
$\overline{\text{INIT}}$	89	O	OD ₁₄ , O _{14/14}	V _{DD}	Initialize. When low, initializes the printer. This signal is in TRI-STATE after a 1 is loaded into the corresponding control register bit. Use an external 4.7 K Ω pull-up resistor.
PD7-5 PD4-3, PD2, PD1 PD0	80-82 85-86 88, 90 92	I/O	IN _T / OD ₁₄ , O _{14/14}	V _{DD}	Parallel Port Data. Transfer data to and from the peripheral data bus and the appropriate Parallel Port data register. These signals have a high current drive capability.
PE	77	I	IN _T	V _{DD}	Paper End. Set high by the printer when it is out of paper. This pin has an internal weak pull-up or pull-down resistor.
SLCT	76	I	IN _T	V _{DD}	Select. Set active high by the printer when the printer is selected.
$\overline{\text{SLIN_ASTRB}}$	87	O	OD ₁₄ , O _{14/14}	V _{DD}	SLIN - Select Input. When low, selects the printer. This signal is in TRI-STATE after a 0 is loaded into the corresponding control register bit. Uses an external 4.7 K Ω pull-up resistor. ASTRB - Address Strobe (EPP). Active low, used in EPP mode to denote an address or data cycle. When the cycle is aborted, $\overline{\text{ASTRB}}$ becomes inactive (high).
$\overline{\text{STB_WRITE}}$	94	O	OD ₁₄ , O _{14/14}	V _{DD}	STB - Data Strobe. When low, Indicates to the printer that valid data is available at the printer port. This signal is in TRI-STATE after a 0 is loaded into the corresponding control register bit. An external 4.7 K Ω pull-up resistor should be employed. WRITE - Write Strobe. Active low, used in EPP mode to denote an address or data cycle. When the cycle is aborted, $\overline{\text{WRITE}}$ becomes inactive (high).

1.4.12 Power and Ground

Signal	Pin/s	I/O	Buffer Type	Power Well	Description
AV _{SS}	45	I	AGND	-	Analog Ground
AV _{DD}	44	I	PWR	-	Analog 3.3V Power Supply Provides power to the analog circuits.
V _{BAT}	30	I	IN _{ULR}	-	Battery Power Supply. Provides battery back-up to the System Wake-Up Control registers, when V _{SB} is lost (power-fail). The pin is connected to the internal logic through a series resistor for UL protection.

1.0 Signal/Pin Connection and Description (Continued)

Signal	Pin/s	I/O	Buffer Type	Power Well	Description
V _{DD}	20, 52, 83, 115	I	PWR	-	Main 3.3V Power Supply
V _{SB}	31	I	PWR	-	Standby 3.3V Power Supply. Provides power to the Wake-Up Control circuitry, while the main power supply is turned off.
V _{SS}	19, 51, 84, 116	I	GND	-	Ground

1.4.13 Protection

Signal	Pin(s)	I/O	Buffer Type	Power Well	Description
CHASI	29	I	IN _C	V _{PP}	Chassis Intrusion Input. Any change of this pin sets the intrusion detection. For correct operation, this pin must be tied to V _{SS} when it is not used.
$\overline{\text{CHASO}}$	28	O	OD ₆	V _{SB}	Chassis Intrusion Output. When low, indicates that an intrusion indication is set.

1.4.14 Serial Port 1 and Serial Port 2

Signal	Pin/s	I/O	Buffer Type	Power Well	Description
$\overline{\text{CTS1}}$ $\overline{\text{CTS2}}$	100 108	I	IN _{TS}	V _{DD}	Clear to Send. When low, indicate that the modem or other data transfer device is ready to exchange data.
$\overline{\text{DCD1}}$ $\overline{\text{DCD2}}$	95 103	I	IN _{TS}	V _{DD}	Data Carrier Detected. When low, indicate that the modem or other data transfer device has detected the data carrier.
$\overline{\text{DSR1}}$ $\overline{\text{DSR2}}$	96 104	I	IN _{TS}	V _{DD}	Data Set Ready. When low, indicate that the data transfer device, e.g., modem, is ready to establish a communications link.
$\overline{\text{DTR1_BOUT1}}$ $\overline{\text{DTR2_BOUT2}}$	101 109	O	O _{3/6}	V _{DD}	Data Terminal Ready. When low, indicate to the modem or other data transfer device that the UART is ready to establish a communications link. After a system reset, these pins provide the DTR function and set these signals to inactive high. Loopback operation holds them inactive. Baud Output. Provides the associated serial channel baud rate generator output signal if test mode is selected, i.e., bit 7 of the EXCR1 Register is set. $\overline{\text{DTR1_BOUT1}}$ is used also as BADDR.
$\overline{\text{RI1}}$ $\overline{\text{RI2}}$	102 110	I	IN _{TS}	V _{DD} , V _{SB}	Ring Indicator. When low, indicate that a telephone ring signal has been received by the modem. They are monitored during power-off for wake-up event detection.
$\overline{\text{RTS1}}$ $\overline{\text{RTS2}}$	98 106	O	O _{3/6}	V _{DD}	Request to Send. When low, indicate to the modem or other data transfer device that the corresponding UART is ready to exchange data. A system reset sets these signals to inactive high, and loopback operation holds them inactive. $\overline{\text{RTS1}}$ is used also as TEST.
SIN1 SIN2	97 105	I	IN _{TS}	V _{DD}	Serial Input. Receive composite serial data from the communications link (peripheral device, modem or other data transfer device).
SOUT1 SOUT2	99 107	O	O _{3/6}	V _{DD}	Serial Output. Send composite serial data to the communications link (peripheral device, modem or other data transfer device). These signals are set active high after a system reset.

1.0 Signal/Pin Connection and Description (Continued)

1.4.15 Strap Configuration

Signal	Pin/s	I/O	Buffer Type	Power Well	Description
BADDR	101	I	IN _{STRP}	V _{DD}	Base Address. Sampled by the trailing edge of the system reset to determine the base address of the configuration Index-Data register pair. During reset, it is pulled down by internal 30Kohm resistor. If no pull-up resistor is connected, it is sampled low, setting the Index-Data pair at 2Eh-2Fh. Connecting a 10K external pull-up resistor to V _{DD} would make it sample high, setting the Index-Data pair at 4Eh-4Fh.
PSLDC0 PSLDC1	99 107	I	IN _{STRP}	V _{SB} ^{Note 1.}	Power Supply and LED Configuration. If no pull-up resistor is connected to these pins, pins 33-35 and 37 function as PWBTOUT, PSON, PWBTTIN and SLPS5 respectively. Connecting a 10K external pull-up resistor to V _{SB} causes these pins to function as GPOS0, GPOS1, GPIS2, and AVIO, respectively.
PSONPOL	109	I	IN _{STRP}	V _{SB} ^{Note 1.}	Power Supply On Polarity. If no pull-up resistor is connected to this pin, PSON is set active low with open-drain output. Connecting a 10K external pull-up resistor to V _{SB} causes PSON to be set to active high with push-pull output.
TEST	98	I	IN _{STRP}	V _{DD}	Test. If sampled high on the trailing edge of system reset, this signal forces the device into test mode. This pin is for National Semiconductor use only, and should be left unconnected.

Note 1. Make sure that the Serial Port driver is back-drive protected.

1.4.16 System Hardware Monitoring

Signal	Pin(s)	I/O	Buffer Type	Power Well	Description
ALARM	27	O	OD ₆	V _{SB}	Alarm. Alerts on voltage input mismatch
AVIO-6	37-43	I	IN _{AN1}	AV _{DD}	Analog Voltage Inputs. Analog inputs of the A/D converter.
D1N D2N	47 49	I	IN _{AN3}	AV _{DD}	Diode Cathode. Diodes 1 and 2 return current sink. Must be grounded when not used.
D1P D2P	48 50	O	O _{AN2}	AV _{DD}	Diode Anode. Diodes 1 and 2 current source. Connected to remote discrete diodes
OTS1 OTS2	24 25	O	OD ₆	V _{SB}	Overtemperature Shutdown. Indicate that an overtemperature was detected. See Section 2.8.9, the SuperI/O Configuration A register, bit 0, for further details on which pin/s is/are active for remote and local temperature sensing.
TS1-3	47-49	I	IN _{AN1}	AV _{DD}	Thermistor Sensors. Analog inputs.
V _{REF}	46	I/O	IN _{AN2} , O _{AN1}	AV _{DD}	Reference Voltage. Provides reference voltage for the on-chip A/D circuits. An external reference voltage should be connected to this input.

1.0 Signal/Pin Connection and Description (Continued)

1.4.17 System Wake-Up Control

Signal	Pin/s	I/O	Buffer Type	Power Well	Description
LED1 LED2	25 26	O	O _{12/12}	V _{SB}	LED. V _{SB} -powered pins with programmable outputs, each of which can be used to produce a 0, 0.25, 0.5, 1, 4 Hz waveform for LED control.
GPIE6-7	58-59	I	IN _{TS}	V _{SB}	General-Purpose Input Event
GPIOE0-5	23-28	I/O	IN _{TS} / OD ₆ , O _{3/6}	V _{SB}	General-Purpose I/O Event. V _{SB} -powered pins.
GPIS2	35	I	IN _{TS}	V _{SB}	General-Purpose Input Standby. V _{SB} -powered pin.
GPOS0-1	33-34	O	OD ₆ , O _{3/6}	V _{SB}	General-Purpose Output Standby. V _{SB} -powered pins.
PSON	34	O	O ₄ , OD ₁₂	V _{SB}	Power Supply On. Active level (low or high via PSONPOL strap) instructs the main power supply to turn the power on. PSON output signal is open-drain when active low and push-pull when active high
PWBTIN	35	I	IN _{TS}	V _{SB}	Power Button In. Active (low) level indicates a user request to turn the power on or off. This pin has an internal Schmidt-trigger input buffer and debounce protection of at least 16 mS.
PWBTOUT	33	O	OD ₁₂	V _{SB}	Power Button Out. Active (low) level serves as output to the chipset power button input.
PWUREQ	32	O	OD ₆	V _{SB}	Power-Up Request. Active (low) level indicates that wake-up event has occurred, and causes the chipset to turn the power supply on, or to exit its current sleep state. The open-drain output must be pulled up to V _{SB} in order to function during power-off.
RING	27	I	IN _{TS}	V _{SB}	Telephone Line Ring. Detection of a pulse train on the RING pin is a wake-up event that can activate the power-up request (PWUREQ). The pin has a Schmidt-trigger input buffer, powered by V _{SB} .
SLPS3	36	I	IN _{TS}	V _{SB}	Sleep State 3, 4 or 5. Input from this pin is assumed to be driven by the system's ACPI controller to indicate the system's power state.
SLPS5	37	I	IN _{TS}	V _{SB}	Sleep State 4 or 5. Input from this pin is assumed to be driven by the system's ACPI controller to indicate the system's power state.

1.4.18 WATCHDOG Timer (WDT)

Signal	Pin/s	I/O	Buffer Type	Power Well	Description
WDO	56	O	OD ₆ , O _{3/6}	V _{DD}	WATCHDOG Out. Low level indicates that the WATCHDOG Timer has reached its time-out period without being retriggered. The output type and an optional pull-up are configurable.

1.0 Signal/Pin Connection and Description (Continued)

1.5 INTERNAL PULL-UP AND PULL-DOWN RESISTORS

The signals listed in Table 4 can optionally support internal pull-up (PU) and/or pull-down (PD) resistors. See Section 14.3 for the values of each resistor type.

Table 4. Internal Pull-Up and Pull-Down Resistors

Signal	Pin/s	Type	Comments
ACCESS.bus (ACB)			
SCL	54	PU ₂₅	Programmable
SDA	55	PU ₂₅	Programmable
Game Port (GMP)			
JOYABTN0	119	PU ₂₅	Programmable
JOYABTN1	120	PU ₂₅	Programmable
JOYBBTN0	123	PU ₂₅	Programmable
JOYBBTN1	124	PU ₂₅	Programmable
General-Purpose Input/Output (GPIO) Ports			
GPIO00-07	2-9	PU ₂₅	Programmable
GPIO10 GPIO11-14 GPIO15 GPIO16-17	21 53-56 57 69, 71	PU ₂₅	Programmable
GPIO20-27	117-124	PU ₂₅	Programmable
GPIO30-33 GPIO34	125-128 1	PU ₂₅	Programmable
Keyboard and Mouse Controller (KBC)			
P12, P16, P17	6,127,7	PU ₂₅	
Musical Instrument Digital Interface (MIDI) Port			
MDRX	126	PU ₂₅	Programmable
Strap Configuration			
BADDR	101	PD ₃₀	Strap
PSLDC0	99	PD ₃₀	Strap
PSLDC1	107	PD ₃₀	Strap
PSONPOL	109	PD ₃₀	Strap
TEST	98	PD ₃₀	Strap
Parallel Port			
ACK	79	PU ₅₀	
AFD_DSTRB	93	PU ₁₀₀	
BUSY_WAIT	78	PD ₃₀	
ERR	91	PU ₅₀	

1.0 Signal/Pin Connection and Description (Continued)

Signal	Pin/s	Type	Comments
INIT	89	PU ₁₀₀	
PE	77	PU ₅₀ / PD ₃₀	Programmable
SLCT	76	PD ₃₀	
SLIN_ASTRB	87	PU ₁₀₀	
STB_WRITE	94	PU ₁₀₀	
System Wake-Up Control (SWC)			
GPIE6-7	58-59	PU ₂₅	Programmable
GPIOE0-5	23-28	PU ₂₅	Programmable
GPIS2	35	PU ₁₀₀	
PSON/GPOS1	34	PU ₁₀₀	
PWBTIN	35	PU ₅₀	
PWBTOUT	33	PU ₁₀₀	
RING	27	PU ₂₅	
WATCHDOG Timer (WDT)			
WDO	56	PU1	Programmable

2.0 Device Architecture and Configuration

The PC87366 SuperI/O device comprises a collection of generic and proprietary functional blocks. Each functional block is described in a separate chapter in this document. However, some parameters in the implementation of each functional block may vary per SuperI/O device. This chapter describes the PC87366 structure and provides all logical device specific information, including special implementation of generic blocks, system interface and device configuration.

2.1 OVERVIEW

The PC87366 consists of 15 logical devices, the host interface, and a central set of configuration registers, all built around a central, internal bus. The internal bus is similar to an 8-bit ISA bus protocol. See Figure 1, which illustrates the blocks and related logic.

The system interface serves as a bridge between the external LPC interface and the internal bus. It supports 8-bit I/O Read, 8-bit I/O Write and 8-bit DMA transactions, as defined in Intel's *LPC Interface Specification, Revision 1.0*.

The central configuration register set supports ACPI compliant PnP configuration. The configuration registers are structured as a subset of the Plug and Play Standard registers, defined in Appendix A of the *Plug and Play ISA Specification, Revision 1.0a* by Intel and Microsoft. All system resources assigned to the functional blocks (I/O address space, DMA channels and IRQ lines) are configured in, and managed by, the central configuration register set. In addition, some function-specific parameters are configurable through the configuration registers and distributed to the functional blocks through special control signals.

2.2 CONFIGURATION STRUCTURE AND ACCESS

The configuration structure is comprised of a set of banked registers which are accessed via a pair of specialized registers.

2.2.1 The Index-Data Register Pair

Access to the SuperI/O configuration registers is via an Index-Data register pair, using only two system I/O byte locations. The base address of this register pair is determined during reset, according to the state of the hardware strapping option on the BADDR pin. Table 5 shows the selected base addresses as a function of BADDR.

Table 5. BADDR Strapping Options

BADDR	I/O Address	
	Index Register	Data Register
0	2Eh	2Fh
1	4Eh	4Fh

The Index register is an 8-bit R/W register located at the selected base address (Base+0). It is used as a pointer to the configuration register file, and holds the index of the configuration register that is currently accessible via the Data register. Reading the Index register returns the last value written to it (or the default of 00h after reset).

The Data register is an 8-bit virtual register, used as a data path to any configuration register. Accessing the Data register actually accesses the configuration register that is currently pointed to by the Index register.

2.0 Device Architecture and Configuration (Continued)

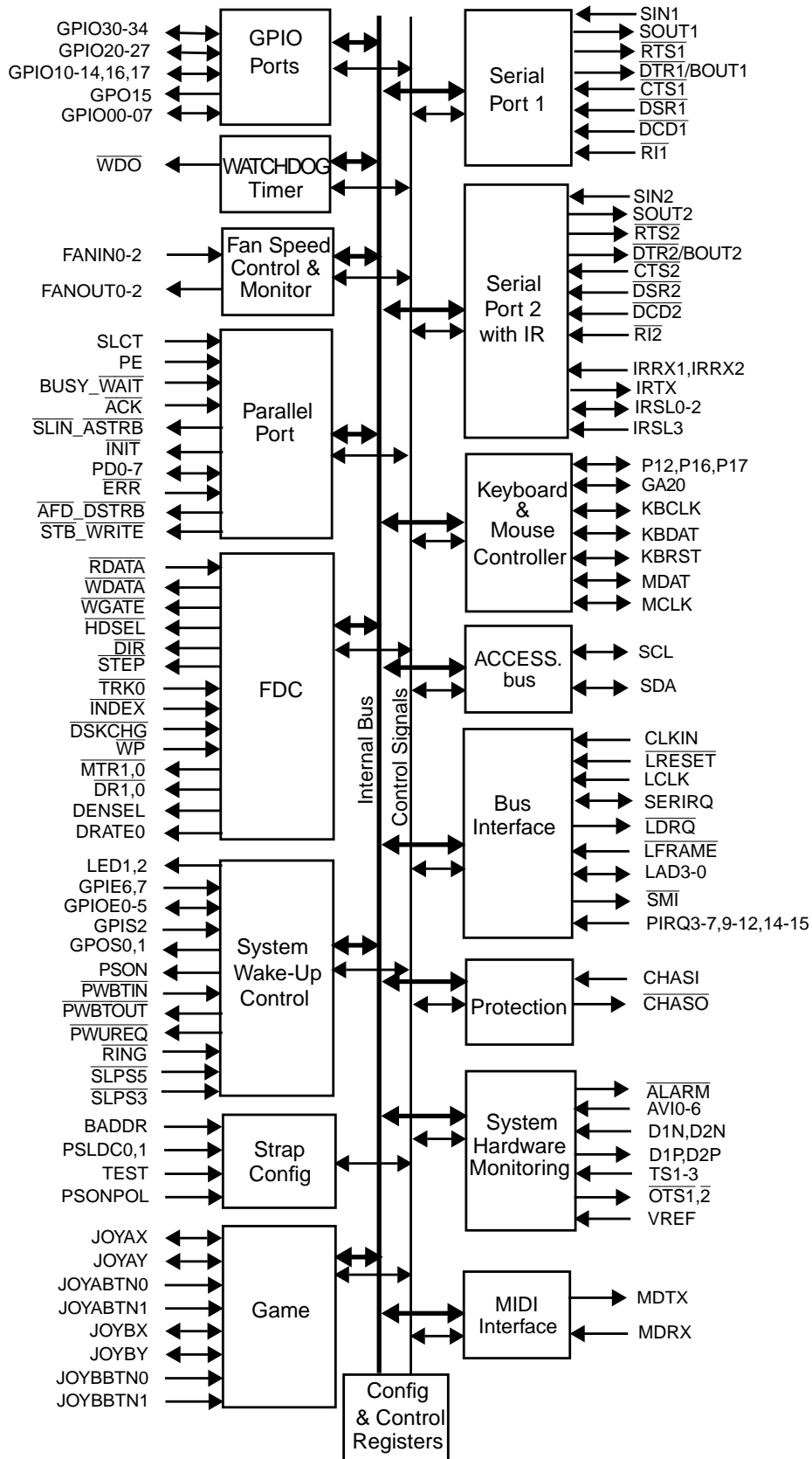

Figure 1. PC87366 Detailed Block Diagram

2.0 Device Architecture and Configuration (Continued)

2.2.2 Banked Logical Device Registers Structure

Each functional block is associated with a Logical Device Number (LDN). The configuration registers are grouped into banks, where each bank holds the standard configuration registers of the corresponding logical device. Table 6 shows the LDN values of the PC87366 functional blocks.

Figure 2 shows the structure of the standard configuration register file. The SuperI/O control and configuration registers are not banked and are accessed by the Index-Data register pair only, as described above. However, the device control and device configuration registers are duplicated over 15 banks for 15 logical devices. Therefore, accessing a specific register in a specific bank is performed by two dimensional indexing, where the LDN register selects the bank (or logical device) and the Index register selects the register within the bank. Accessing the Data register while the Index register holds a value of 30h or higher results in a physical access to the Logical Device Configuration registers currently pointed to by the Index register, within the logical device currently selected by the LDN register.

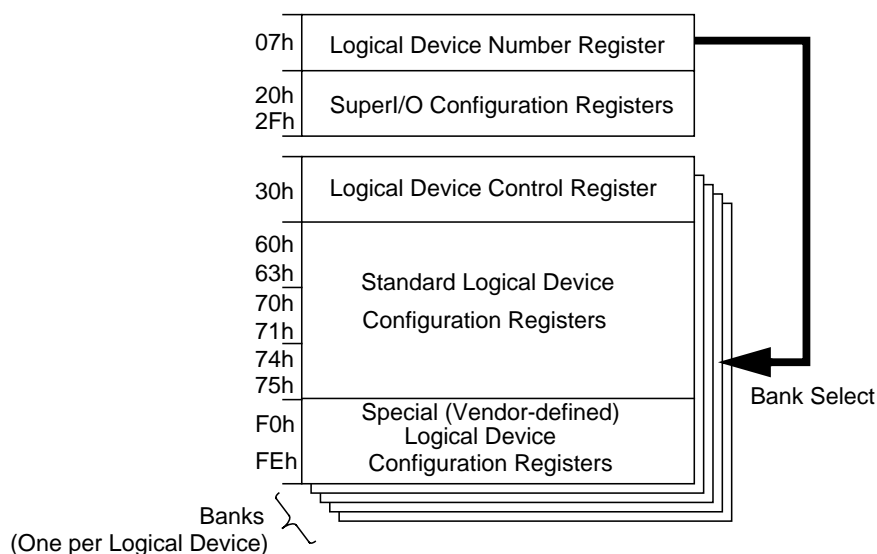

Figure 2. Structure of the Standard Configuration Register File

Table 6. Logical Device Number (LDN) Assignments

LDN	Functional Block
00h	Floppy Disk Controller (FDC)
01h	Parallel Port (PP)
02h	Serial Port 2 with IR (SP2)
03h	Serial Port 1 (SP1)
04h	System Wake-Up Control (SWC)
05h	Keyboard and Mouse Controller (KBC) - Mouse interface
06h	Keyboard and Mouse Controller (KBC) - Keyboard interface
07h	General-Purpose I/O (GPIO) Ports
08h	ACCESS.bus Interface (ACB)
09h	Fan Speed Control and Monitor (FSCM)
0Ah	WATCHDOG Timer (WDT)
0Bh	Game Port (GMP)
0Ch	Musical Instrument Digital Interface (MIDI) Port
0Dh	Voltage Level Monitor (VLM)
0Eh	Temperature Sensor (TMS)

2.0 Device Architecture and Configuration (Continued)

Write accesses to unimplemented registers (i.e. accessing the Data register while the Index register points to a non-existing register), are ignored and read returns 00h on all addresses except for 74h and 75h (DMA configuration registers) which returns 04h (indicating no DMA channel is active). The configuration registers are accessible immediately after reset.

2.2.3 Standard Logical Device Configuration Register Definitions

Unless otherwise noted in Tables 7 through 12:

- All registers are read/write.
- All reserved bits return 0 on reads, except where noted otherwise. They must not be modified as it may cause unpredictable results. Use read-modify-write to prevent the values of reserved bits from being changed during write.
- Write only registers should not use read-modify-write during updates.

Table 7. Standard Control Registers

Index	Register Name	Description
07h	Logical Device Number	This register selects the current logical device. See Table 6 for valid numbers. All other values are reserved.
20h - 2Fh	SuperI/O Configuration	SuperI/O configuration registers and ID registers

Table 8. Logical Device Activate Register

Index	Register Name	Description
30h	Activate	Bit 0 - Logical device activation control 0: Disabled 1: Enabled Bits 7-1 - Reserved

Table 9. I/O Space Configuration Registers

Index	Register Name	Description
60h	I/O Port Base Address Bits (15-8) Descriptor 0	Indicates selected I/O lower limit address bits 15-8 for I/O Descriptor 0.
61h	I/O Port Base Address Bits (7-0) Descriptor 0	Indicates selected I/O lower limit address bits 7-0 for I/O Descriptor 0.
62h	I/O Port Base Address Bits (15-8) Descriptor 1	Indicates selected I/O lower limit address bits 15-8 for I/O Descriptor 1.
63h	I/O Port Base Address Bits (7-0) Descriptor 1	Indicates selected I/O lower limit address bits 7-0 for I/O Descriptor 1.

2.0 Device Architecture and Configuration (Continued)

Table 10. Interrupt Configuration Registers

Index	Register Name	Description
70h	Interrupt Number and Wake-Up on IRQ Enable	Indicates selected interrupt number. Bit 4 - Enables wake-up on the IRQ of the logical device. When enabled, IRQ assertion triggers a wake-up event. 0: Disabled (default) 1: Enabled Bits 3-0 select the interrupt number. A value of 1 selects IRQ1, a value of 2 selects IRQ2, etc. (up to IRQ15). IRQ0 is not a valid interrupt selection.
71h	Interrupt Request Type Select	Indicates the type and level of the interrupt request number selected in the previous register. Bit 0 - Type of interrupt request selected in previous register 0: Edge 1: Level Bit 1 - Level of interrupt request selected in previous register 0: Low polarity 1: High polarity

Table 11. DMA Configuration Registers

Index	Register Name	Description
74h	DMA Channel Select 0	Indicates selected DMA channel for DMA 0 of the logical device (0 - The first DMA channel in case of using more than one DMA channel). Bits 2-0 select the DMA channel for DMA 0. The valid choices are 0-3, where a value of 0 selects DMA channel 0, 1 selects channel 1, etc. A value of 4 indicates that no DMA channel is active. The values 5-7 are reserved.
75h	DMA Channel Select 1	Indicates selected DMA channel for DMA 1 of the logical device (1 - The second DMA channel in case of using more than one DMA channel). Bits 2-0 select the DMA channel for DMA 1. The valid choices are 0-3, where a value of 0 selects DMA channel 0, 1 selects channel 1, etc. A value of 4 indicates that no DMA channel is active. The values 5-7 are reserved.

Table 12. Special Logical Device Configuration Registers

Index	Register Name	Description
F0h-FEh	Logical Device Configuration	Special (vendor-defined) configuration options.

2.0 Device Architecture and Configuration (Continued)

2.2.4 Standard Configuration Registers

Index	Register Name
07h	Logical Device Number
20h	SuperI/O ID
21h	SuperI/O Configuration 1
22h	SuperI/O Configuration 2
23h	SuperI/O Configuration 3
24h	SuperI/O Configuration 4
25h	SuperI/O Configuration 5
26h	SuperI/O Configuration 6
27h	SuperI/O Revision ID
28h	SuperI/O Configuration 8
2Ah	SuperI/O Configuration A
2Bh	SuperI/O Configuration B
2Ch	SuperI/O Configuration C
2Dh	SuperI/O Configuration D
2Eh	Reserved exclusively for National use
30h	Logical Device Control (Activate)
60h	I/O Base Address Descriptor 0 Bits 15-8
61h	I/O Base Address Descriptor 0 Bits 7-0
62h	I/O Base Address Descriptor 1 Bits 15-8
63h	I/O Base Address Descriptor 1 Bits 7-0
70h	Interrupt Number and Wake-Up on IRQ Enable
71h	IRQ Type Select
74h	DMA Channel Select 0
75h	DMA Channel Select 1
F0h	Device Specific Logical Device Configuration 1
F1h	Device Specific Logical Device Configuration 2
F2h	Device Specific Logical Device Configuration 3

Figure 3. Configuration Register Map

SuperI/O Control and Configuration Registers

The SuperI/O Configuration registers at indexes 20h and 27h are mainly used for part identification, global power management and the selection of pin multiplexing options. For details, see Section 2.8.

Logical Device Control and Configuration Registers

A subset of these registers is implemented for each logical device. See functional block description in the following sections.

2.0 Device Architecture and Configuration (Continued)

Control

The only implemented control register for each logical device is the Activate register at index 30h. Bit 0 of the Activate register controls the activation of the associated function block. Activation of the block enables access to the block's registers, and attaches its system resources, which are unused as long as the block is not activated. Other effects may apply, on a function-specific basis (such as clock enable and active pinout signaling).

Standard Configuration

The standard configuration registers are used to manage the PnP resource allocation to the functional blocks. The I/O port base address descriptor 0 is a pair of registers at Index 60-61h, holding the (first or only) 16-bit base address for the register set of the functional block. An optional 16-bit second base-address (descriptor 1) at index 62-63h is used for logical devices with more than one continuous register set. Interrupt Number and Wake-Up on IRQ Enable (index 70h) and IRQ Type Select (index 71h) allocate an IRQ line to the block and control its type. DMA Channel Select 0 (index 74h) allocates a DMA channel to the block, where applicable. DMA Channel Select 1 (index 75h) allocates a second DMA channel, where applicable.

Special Configuration

The vendor-defined registers, starting at index F0h, are used to control function-specific parameters such as operation modes, power saving modes, pin TRI-STATE, clock rate selection, and non-standard extensions to generic functions.

2.2.5 Default Configuration Setup

The default configuration setup of the PC87366 can include four reset types, described below. See specific register descriptions for the bits affected by each reset type.

- **Software Reset**

This reset is enabled by bit 1 of the SIOCF1 register, which resets all logical devices. A software reset also resets most bits in the SuperI/O control and configuration registers (see Section 2.8 for the bits not affected). This reset does not affect register bits that are locked for write access.

- **Hardware Reset**

This reset is activated by the assertion of the $\overline{\text{LRESET}}$ input. It resets all logical devices, with the exception of the System Wake-Up Control (SWC). It also resets all SuperI/O control and configuration registers, except for those that are battery-backed.

- **V_{PP} Power-Up Reset**

This reset is activated when either V_{SB} or V_{BAT} is powered up after both have been off. V_{PP} is an internal voltage which is a combination of V_{SB} and V_{BAT}. V_{PP} is taken from V_{SB} if V_{SB} is greater than the minimum (Min) value defined in the *Device Characteristics* chapter; otherwise, V_{BAT} is used as the V_{PP} source. This reset resets all registers whose values are retained by V_{PP}.

- **V_{SB} Power-Up Reset**

This is an internally generated reset that resets the SWC, excluding those SWC registers whose values are retained by V_{PP}. This reset is activated after V_{SB} is powered up.

In event of a hardware reset, the PC87366 wakes up with the following default configuration setup:

- The configuration base address is 2Eh or 4Eh, according to the BADDR strap pin value, as shown in Table 5.
- The Keyboard Controller (KBC) is active and all other logical devices are disabled, with the exception of the SWC which remains functional but whose registers cannot be accessed.
- All multiplexed GPIO pins, except for pins whose function is controlled by battery-backed registers and pins 8 and 9 (which are controlled by bits 1 and 0 of the SIOCF3 register) are configured as GPIO pins, with an internal static pull-up (default direction is input).

In event of either a hardware or a software reset, the PC87366 wakes up with the following default configuration setup:

- The legacy devices are assigned with their legacy system resource allocation.
- The National proprietary functions are not assigned with any default resources and the default values of their base addresses are all 00h.

2.2.6 Power States

The following terminology is used in this document to describe the various possible power states:

- **Power On**

Both V_{SB} and V_{DD} are active.

- **Power Off**

V_{SB} is active and V_{DD} is inactive.

2.0 Device Architecture and Configuration (Continued)

- **Power Fail**

Both V_{SB} and V_{DD} are inactive.

Note: The following state is illegal: V_{DD} active and V_{SB} inactive.

2.2.7 Address Decoding

A full 16-bit address decoding is applied when accessing the configuration I/O space as well as the registers of the functional blocks. However, the number of configurable bits in the base address registers varies for each logical device.

The lower 1, 2, 3, 4 or 5 address bits are decoded within the functional block to determine the offset of the accessed register, within the logical device's I/O range of 2, 4, 8, 16 or 32 bytes, respectively. The rest of the bits are matched with the base address register to decode the entire I/O range allocated to the logical device. Therefore the lower bits of the base address register are forced to 0 (read only), and the base address is forced to be 2, 4, 8, 16 or 32 byte-aligned, according to the size of the I/O range.

The base address of the FDC, Serial Port 1, Serial Port 2 with IR and KBC are limited to the I/O address range of 00h to 7Fh only (bits 11-15 are forced to 0). The Parallel Port base address is limited to the I/O address range of 00h to 3Fh. The addresses of the non-legacy logical devices, including the GMP and the MIDI, are configurable within the full 16-bit address range (up to FFFh).

In some special cases, other address bits are used for internal decoding (such as bit 2 in the KBC and bit 10 in the Parallel Port). The KBC has two I/O descriptors with some implied dependency between them. For more details, see the description of the base address register for each logical device.

2.3 PROTECTION

The PC87366 provides features to protect the PC at mechanical and software levels.

At the mechanical level, the device can detect intrusion to the chassis of the PC.

At the software level, the device can be locked to protect configuration bits or alteration of the hardware configuration of the device, as well as internal GPIO settings and several types of configuration settings.

All protection mechanisms can optionally be used.

2.3.1 Chassis Intrusion Detection

The Chassis Intrusion Detection mechanism is based on the state of pin 29, CHASI. This pin reflects the status of an external switch that indicates the PC chassis state.

Bits 4,5 of the SIOCFB register monitor this pin, and provide two types of information. Bit 4 reports a previously detected chassis intrusion, defined as any kind of transition on the CHASI pin. Bit 5 reflects the momentary value of the CHASI pin. For further details on the SIOCFB register, see Section 2.8.10.

To prevent the CHASI pin from detecting a false chassis intrusion, it is implemented with an internal noise filter.

A chassis intrusion event can be reported to the host system by either software or hardware. When using software, the system must read the SIOCFB register to check if an intrusion event has occurred. When using hardware, the device provides the following means for indicating chassis intrusion:

- Dedicated output (\overline{CHASO})
- \overline{SMI} assertion.

To use the \overline{CHASO} function, it must first be selected by setting bit 6 of the SIOCFB register to 1. Thereafter, whenever a chassis intrusion is detected, the \overline{CHASO} pin reflects the value of bit 4 of the SIOCFB register. When bit 4 of this register is set to 1, the \overline{CHASO} pin is asserted (driven low). It is deasserted when this bit is cleared.

To use the \overline{SMI} assertion, it must either be selected on its pin or routed to interrupt request channel 2. To select \overline{SMI} on its pin, set bit 2 of the SIOCF3 register to 1 (for further details, see Section 2.8.4). To route the SMI signal to interrupt request channel 2, set bit 4 of the SIOCF5 register to 1 (for further details, see Section 2.8.6). In addition, the chassis intrusion event must be routed to the \overline{SMI} signal by setting bit 5 of the SIOCF8 register to 1 (for further details, see Section 2.8.8). Thereafter, whenever a chassis intrusion is detected, the \overline{SMI} signal reflects bit 4 of the SIOCFB register. When bit 4 of this register is set to 1, the \overline{SMI} signal and the selected target indication are asserted (driven low). The \overline{SMI} signal is deasserted when this bit 4 is cleared.

2.3.2 Pin Configuration Lock

To lock the pin configuration of the PC87366 in order to prevent unwanted changes to hardware configuration, set bit 7 of the SIOCF1 register to 1. Setting this bit causes all function select configuration bits, including those that are battery backed, to become read only bits. This bit can only be cleared by a hardware reset.

2.0 Device Architecture and Configuration (Continued)

2.3.3 GPIO Pin Function Lock

The PC87366 is capable of locking the attributes of each GPIO or Standby GPIO pin. The following attributes can be locked:

- Output enable
- Output type
- Static pull-up
- Driven data.

GPIO pins are locked per pin by setting the Lock bit in the appropriate GPIO Pin Configuration register. When the Lock bit is set, the configuration of the associated GPIO pin can only be released by a hardware reset.

Standby GPIO pins are locked in the same manner by setting the Lock bit in the appropriate Standby GPIO Pin Configuration registers. However, once a Standby GPIO pin is locked, its locked attributes can only be released with a V_{SB} power-up reset.

2.4 POWER SUPPLY CONTROL (PSC)

The PC87366 includes hardware that can be used to ease the system's control over the computer's power supply. This hardware is implemented as a state machine that determines the required state of the power supply based on several input signals, and also connects to the system's ACPI controller to share information about the system's power state via specific interface signals.

The PSC uses the pin functions $\overline{SLPS3}$, $\overline{SLPS5}$, \overline{PWBTIN} , $\overline{PWBTOUT}$ and PSON. These functions are optional on their respective pins and must be selected to enable the PSC by setting the values of the PSLDC0,1 strap pins (see Table 14).

Once enabled, the PSC can be operated in one of two modes, according to the value of bit 0 (Power Button Mode) of the SIOCFD register:

- ACPI mode
- Legacy mode

ACPI Mode

When the PSC is operated in ACPI mode (bit 0 of the SIOCFD register is set to 1), the ACPI controller of the system controls the system's power supply by means of the $\overline{SLPS3}$ state. When $\overline{SLPS3}$ is set to 0, the power supply turns off; when it is set to 1, the power supply turns on. The state of the PSON output signal (either ON or OFF) is identical to the state of the $\overline{SLPS3}$ input signal. The polarity of PSON is set by the PSONPOL strap.

The only case in which the PSC affects the value of the PSON output is when a Crowbar condition occurs. A Crowbar condition is defined as the state in which PSON has been active for a certain period of time, but the system's power supply remains inactive. In this case, PSON is forced inactive, and the $\overline{PWBTOUT}$ output is pulsed to indicate to the ACPI controller that $\overline{SLPS3}$ must be driven low, thus indirectly inactivating PSON and preventing a deadlock. For a detailed description of the Crowbar mechanism, see "Crowbar Condition" below.

In ACPI mode, during regular operation, the $\overline{PWBTOUT}$ output is pulsed when either of the following events occurs:

- \overline{PWBTIN} is pulsed.
- A wake-up event, that is routed to $\overline{PWBTOUT}$.

A wake-up event that is routed to the power button output can cause $\overline{PWBTOUT}$ to be pulsed in ACPI mode if one of the following conditions is met:

- $\overline{SLPS5}$ is active.
- Enable Power Button Pulse on S3 (bit 3) of the SWC WK_CFG register is set to 1.

However, when in ACPI mode, \overline{PWBTIN} and $\overline{PWBTOUT}$ activity has no effect on the PSON output. The power button mechanism can have an indirect effect on PSON only if $\overline{PWBTOUT}$ is connected to the power button input of the ACPI controller, thus affecting the $\overline{SLPS3}$ signal.

Legacy Mode

When the PSC is operated in Legacy mode (bit 0 of the SIOCFD register is set to 0), the PC87366 controls the system's power supply. In this mode, the PSON output signal is set by the PC87366 according to the following factors: the state of input signals, the state of the power supply lines, power button activity and certain configuration bits. Although the ACPI controller does not control the system's power supply, it tracks the system's power state. For this purpose, the PC87366 ma-

2.0 Device Architecture and Configuration (Continued)

nipulates the $\overline{\text{PWBTOUT}}$ so that the ACPI controller is always synchronized with the actual state of the PSON output. This synchronization mechanism assumes that $\overline{\text{PWBTOUT}}$ is connected to the power button input of the ACPI controller. See a schematic state diagram of the Legacy PSC mechanism in Figure 4.

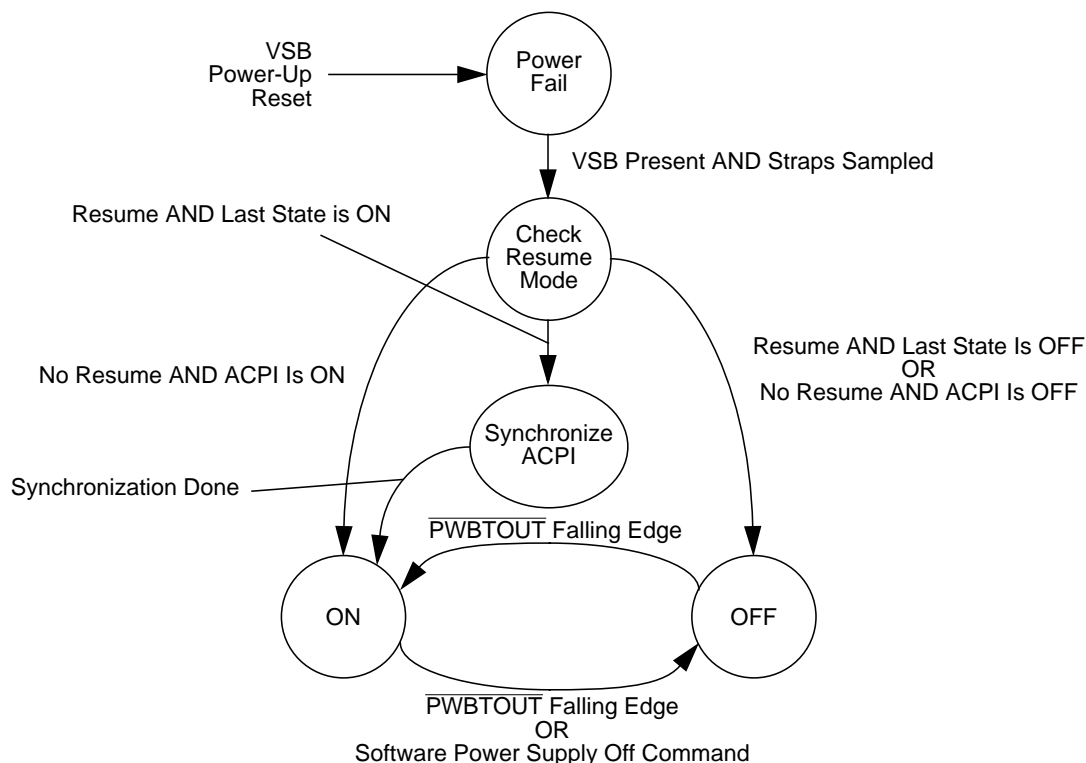

Figure 4. Legacy Power Supply Control State Diagram

When V_{SB} is first applied, the PSC state machine is initialized to Power Fail state. In this state, the mechanism waits for the PC87366 to be initialized according to strap options. Then the PSC enters Check Resume Mode state. In this state, the PSC checks if Resume to Last PSON state is enabled.

If Resume to Last PSON is enabled, PSON immediately resumes the state it was in when V_{SB} was lost. To enable this mechanism, set bit 2 of the SIOCFD register to 1, and program the ACPI controller to resume OFF state ($\overline{\text{SLPS3}} = 0$) after power fail recovery to allow the PSC to operate properly. If the last state of PSON was OFF, assuming that the ACPI controller also resumed OFF state, PSON is set to inactive and the PSC enters OFF state. If the last state was ON, under the same assumption, the ACPI controller must be notified to change its state to ON. This is done by pulsing the $\overline{\text{PWBTOUT}}$ output. This synchronization pulse is generated when the PSC is in Synchronize ACPI state.

If Resume Last PSON State is disabled, the PSC enters either ON or OFF state according to the value of the $\overline{\text{SLPS3}}$ input, as follows:

- If $\overline{\text{SLPS3}}$ is low (active, state OFF), the PSC enters OFF state.
- If $\overline{\text{SLPS3}}$ is high (inactive, state ON), the PSC enters ON state.

Since $\overline{\text{SLPS3}}$ reflects the state of the ACPI controller, the PSC actually resumes the current state of the ACPI controller.

After entering either ON or OFF states, PSC moves between these two states on the following conditions:

- A falling edge on $\overline{\text{PWBTOUT}}$ (generated internally) changes the state from ON to OFF or vice versa.
- A Software Power Supply Off command, writing 1 to Power Supply Off (bit 1) of the SIOCFD register, changes the state from ON to OFF.

Since many wake-up events can activate the $\overline{\text{PWBTOUT}}$ signal, these events can actually cause the PSC to change its state from OFF to ON, thus activating the PSON output.

As in ACPI mode, the Crowbar protection mechanism is also active in Legacy mode. However, in this mode, when a Crowbar condition is detected, the PSC returns to OFF state, thus inactivating the PSON output. Also, to synchronize the ACPI controller, the $\overline{\text{PWBTOUT}}$ is pulsed to bring it to the correct state.

Table 13 summarizes the bit states that affect PSON V_{SB} power-up default state.

2.0 Device Architecture and Configuration (Continued)

Table 13. PSON V_{SB} Power-Up Default State

Resume Last PSON State (SIOCFD, Bit 2)	Last PSON State	PSON V_{SB} Power-Up Default
1	0	0
1	1	1
0	X	Same as SLPS3 state

Crowbar Condition

A Crowbar condition is a situation in which the signal that directly controls the system's power supply is active for a certain duration of time, without a power supply response. To prevent this deadlock and enable reactivation of the power supply, a special crowbar mechanism is included in the PSC logic.

Once the PSON is activated, assuming the power supply is off, a timer in the PSC logic starts counting. If this timer reaches its terminal count before the power supply becomes active, the PSC detects a Crowbar condition. In this case, PSON is deactivated and the PSC makes sure that the ACPI state of the system is changed to OFF.

The time that causes a Crowbar condition is defined as the Crowbar Timeout. The Crowbar Timeout of the PSC can be programmed to values between 0.5-2.25 seconds. This Timeout value is set by writing the appropriate value to bit 4-3 of the SIOCFD register. For further details, refer to the description of this register in Section 2.8.12.

2.5 LED OPERATION AND STATES

The device supports up to two LEDs, depending on Pin 25 and Pin 26 Function Select (bits 1-2 and bit 3) of the SIOCFA register. The polarity of both LEDs is determined by LED Polarity Control (bit 7) of the SIOCFD register.

, when in power-on state. The device also provides modes for hardware LED control. This enables the LEDs to support features such as power and error indication.

The LEDs may be operated in software, hardware1 or hardware 2 modes. These modes are set by LED Mode Control (bits 2 and 3) of the SIOCFC register. Each LED can be set to On, Off or to blink at different rates by means of bits 0-2 (LED1) and bits 3-5 (LED2) of the SIOCFC register. When in power-on state (both V_{DD} and V_{SB} exist), the LEDs are software-controlled. When in power fail state (no V_{SB} and no V_{DD}) the LEDs are off. Table 14 shows the effect of hardware modes 1 and 2 on LED operation that override the above rules.

Table 14. Hardware Modes 1 and 2 Effect on LED Operation

Mode	System State	LED1	LED2
Hardware 1 (SIOCFC, bits 3-2=01)	V_{SB} power-up reset	Off	1 Hz blink, 50% duty cycle
	Power off (V_{SB} , no V_{DD})	Software-controlled	1 Hz blink, 50% duty cycle
Hardware 2 (SIOCFC, bits 3-2=10)	ACPI mode and Sleep State 3	Software-controlled	Software-controlled
	ACPI mode, Sleep State 5, bit 6 = 1 in SIOCFC register and Power Supply Control enabled	Software-controlled	Software-controlled
	ACPI mode, any other configuration	Off	Off
	Legacy mode and power off (no V_{DD})	Off	Off

2.6 POWER SUPPLY CONTROL AND LED CONFIGURATION

A combination of two strap pins (Power Supply and LED Configuration 0 and 1, PSLDC0,1, pins 99 and 107 respectively) determines the configuration of the power supply control pins and LEDs. Both pins 99 and 107 have weak pull-downs, and are sampled on V_{SB} power-up reset. Table 15 describes how they affect the chip configuration.

2.0 Device Architecture and Configuration (Continued)

Table 15. PSLDC0,1 Configuration Options

PSLDC0 (Pin 99)	PSLDC1 (Pin 107)	Power Supply Control	LED2
0	0	Enabled (default)	Not selected (default)
0	1	Disabled	Selected
1	0	Disabled	Not selected
1	1	Enabled	Selected

2.7 REGISTER TYPE ABBREVIATIONS

The following abbreviations are used to indicate the Register Type:

- R/W = Read/Write
- R = Read from a specific address returns the value of a specific register. Write to the same address is to a different register.
- W = Write
- RO = Read Only
- R/W1C = Read/Write 1 to Clear. Writing 1 to a bit clears it to 0. Writing 0 has no effect.

2.8 SUPER I/O CONFIGURATION REGISTERS

This section describes the Super I/O configuration and ID registers (those registers with first level indexes in the range of 20h - 2Eh). See Table 16 for a summary and directory of these registers.

Table 16. Super I/O Configuration Registers

Index	Mnemonic	Register Name	Power Well	Type	Section
20h	SID	Super I/O ID	V _{DD}	RO	2.8.1
21h	SIOCF1	Super I/O Configuration 1	V _{DD}	R/W	2.8.2
22h	SIOCF2	Super I/O Configuration 2	V _{DD}	R/W	2.8.3
23h	SIOCF3	Super I/O Configuration 3	V _{DD}	R/W	2.8.4
24h	SIOCF4	Super I/O Configuration 4	V _{DD}	R/W	2.8.5
25h	SIOCF5	Super I/O Configuration 5	V _{DD}	R/W	2.8.6
27h	SRID	Super I/O Revision ID	V _{DD}	RO	2.8.7
28h	SIOCF8	Super I/O Configuration 8	V _{DD}	R/W	2.8.8
2Ah	SIOCF A	Super I/O Configuration A	V _{PP}	R/W	2.8.9
2Bh	SIOCF B	Super I/O Configuration B	V _{PP}	R/W	2.8.10
2Ch	SIOCF C	Super I/O Configuration C	V _{PP}	R/W	2.8.11
2Dh	SIOCF D	Super I/O Configuration D	V _{PP}	R/W	2.8.12
2Eh	Reserved exclusively for National use				

2.0 Device Architecture and Configuration (Continued)

2.8.1 SuperI/O ID Register (SID)

This register contains the identity number of the chip. The PC87366 is identified by the value E9h.

Location: Index 20h

Type: RO

Bit	7	6	5	4	3	2	1	0
Name	Chip ID							
Reset	1	1	1	0	1	0	0	1

2.8.2 SuperI/O Configuration 1 Register (SIOCF1)

Location: Index 21h

Type: Varies per bit

Bit	7	6	5	4	3	2	1	0
Name	Pin Function Select Lock	Pins 117-127 Function Select	Number of DMA Wait States		Number of I/O Wait States		SW Reset	Global Device Enable
Reset	0	0	0	1	0	0	0	1

Bit	Description
7	Pin Function Select Lock. This bit determines if the bits (located in the SIOCF1, 2, 3, 4, 5, A and B registers) that select pin functions are read only or read/write. When set to 1, this bit can only be cleared by a hardware reset. 0: Bits are R/W. 1: Bits are RO.
6	Pins 117-127 Function Select. This is a RO bit. 0: Pins 117-127 function set by SIOCF4 (default) 1: Reserved
5-4	Number of DMA Wait States. This is a R/W bit. Bits 5 4 Number 0 0 Reserved 0 1 Two (default) 1 0 Six 1 1 Twelve
3-2	Number of I/O Wait States. This is a R/W bit. Bits 3 2 Number 0 0 Zero (default) 0 1 Two 1 0 Six 1 1 Twelve
1	SW Reset. Read always returns 0. This is a R/W bit. 0: Ignored (default) 1: Resets all the logical devices that are reset by hardware reset (with the exception of the lock bits), and resets the registers of the SWC, VLM and TMS
0	Global Device Enable. This bit controls the function enable of all the PC87366 logical devices, except System Wake-Up Control (SWC). With the exception of SWC, it allows all logical devices to be disabled simultaneously by writing to a single bit. This is a R/W bit. 0: All logical devices in the PC87366 are disabled, except SWC, VLM and TMS 1: Each logical device is enabled according to its Activate register (Index 30h) (default)

2.0 Device Architecture and Configuration (Continued)

2.8.3 SuperI/O Configuration 2 Register (SIOCF2)

Location: Index 22h

Type: R/W

Bit	7	6	5	4	3	2	1	0
Name	Pin 7 Function Select	Pin 6 Function Select	Pin 5 Function Select	Pin 4 Function Select	Pin 3 Function Select	Pin 2 Function Select	Pin 1 Function Select	
Reset	0	0	0	0	0	0	0	0

Bit	Description
7	Pin 7 Function Select. 0: GPIO05 (default) 1: P17
6	Pin 6 Function Select. 0: GPIO04 (default) 1: P12
5	Pin 5 Function Select. 0: GPIO03 (default) 1: FANOUT0
4	Pin 4 Function Select. 0: GPIO02 (default) 1: FANIN0
3	Pin 3 Function Select. 0: GPIO01 (default) 1: FANOUT1
2	Pin 2 Function Select. 0: GPIO00 (default) 1: FANIN1
1-0	Pin 1 Function Select. Bits 1 0 Function 0 0 GPIO34 (default) 0 1 FANOUT2 1 x Reserved

2.0 Device Architecture and Configuration (Continued)

2.8.4 SuperI/O Configuration 3 Register (SIOCF3)

Location: Index 23h

Type: Varies per bit

Bit	7	6	5	4	3	2	1	0
Name	Pin 57 Function Select	Pin 56 Function Select	Pins 54, 55 Function Select	Pin 53 Function Select	Reserved	Pin 21 Function Select	Pin 9 Function Select	Pin 8 Function Select
Reset	0	0	0	0	0	0	1	1

Bit	Description
7	Pin 57 Function Select. This is a R/W bit. 0: GPIO15 (default) 1: IRTX
6	Pin 56 Function Select. This is a R/W bit. 0: GPIO14 (default) 1: \overline{WDO}
5	Pins 54, 55 Function Select. This is a R/W bit. 0: GPIO12/GPIO13 (default) 1: SCL/SDA
4	Pin 53 Function Select. This is a RO bit. 0: GPIO11 (default) 1: Reserved
3	Reserved
2	Pin 21 Function Select. This is a R/W bit. 0: GPIO10 (default) 1: \overline{SMI}
1	Pin 9 Function Select. This is a R/W bit. 0: GPIO07 1: GA20 (P21) (default)
0	Pin 8 Function Select. This is a R/W bit. 0: GPIO06 1: KBRST (P20) (default)

2.0 Device Architecture and Configuration (Continued)

2.8.5 SuperI/O Configuration 4 Register (SIOCF4)

Location: Index 24h

Type: R/W

Bit	7	6	5	4	3	2	1	0
Name	Pin 127 Function Select		Pins 125,126 Function Select	Pins 117-124 Function Select	Pin 71 Function Select		Pin 69 Function Select	
Reset	0	0	0	0	0	0	0	0

Bit	Description															
7-6	<p>Pin 127 Function Select.</p> <p>Bits</p> <table border="1"> <thead> <tr> <th>7</th> <th>6</th> <th>Function</th> </tr> </thead> <tbody> <tr> <td>0</td> <td>0</td> <td>GPIO32 (default)</td> </tr> <tr> <td>0</td> <td>1</td> <td>P16</td> </tr> <tr> <td>1</td> <td>0</td> <td>IRSL1</td> </tr> <tr> <td>1</td> <td>1</td> <td>Reserved</td> </tr> </tbody> </table>	7	6	Function	0	0	GPIO32 (default)	0	1	P16	1	0	IRSL1	1	1	Reserved
7	6	Function														
0	0	GPIO32 (default)														
0	1	P16														
1	0	IRSL1														
1	1	Reserved														
5	<p>Pins 125,126 Function Select</p> <p>0: GPIO30,31 (default)</p> <p>1: MDTX, MDRX</p>															
4	<p>Pins 117-124 Function Select</p> <p>0: GPIO20-27 (default)</p> <p>1: JOYAX, JOYAY, JOYABTN0, JOYABTN1, JOYBX, JOYBY, JOYBBTN0, JOYBBTN1</p>															
3-2	<p>Pin 71 Function Select.</p> <p>Bits</p> <table border="1"> <thead> <tr> <th>3</th> <th>2</th> <th>Function</th> </tr> </thead> <tbody> <tr> <td>0</td> <td>0</td> <td>GPIO17 (default)</td> </tr> <tr> <td>0</td> <td>1</td> <td>DR1</td> </tr> <tr> <td>1</td> <td>0</td> <td>IRSL3</td> </tr> <tr> <td>1</td> <td>1</td> <td>Reserved</td> </tr> </tbody> </table>	3	2	Function	0	0	GPIO17 (default)	0	1	DR1	1	0	IRSL3	1	1	Reserved
3	2	Function														
0	0	GPIO17 (default)														
0	1	DR1														
1	0	IRSL3														
1	1	Reserved														
1-0	<p>Pin 69 Function Select.</p> <p>Bits</p> <table border="1"> <thead> <tr> <th>1</th> <th>0</th> <th>Function</th> </tr> </thead> <tbody> <tr> <td>0</td> <td>0</td> <td>GPIO16 (default)</td> </tr> <tr> <td>0</td> <td>1</td> <td>MTR1</td> </tr> <tr> <td>1</td> <td>0</td> <td>IRSL2</td> </tr> <tr> <td>1</td> <td>1</td> <td>Reserved</td> </tr> </tbody> </table>	1	0	Function	0	0	GPIO16 (default)	0	1	MTR1	1	0	IRSL2	1	1	Reserved
1	0	Function														
0	0	GPIO16 (default)														
0	1	MTR1														
1	0	IRSL2														
1	1	Reserved														

2.0 Device Architecture and Configuration (Continued)

2.8.6 SuperI/O Configuration 5 Register (SIOCF5)

Location: Index 25h

Type: Varies per bit

Bit	7	6	5	4	3	2	1	0
Name	VID0 and VID1 Route Select			SMI to IRQ2 Enable	Reserved		Pin 128 Function Select	
Reset	0	0	0	0	0	0	0	0

Bit	Description
7-5	<p>VID0 and VID1 Route Select. Defines the routing of GPIO inputs to the VLM VID register. This is a R/W bit.</p> <p>Bits</p> <p>7 6 5 Route Select</p> <p>0 0 0 VID0 and VID1 are not routed.</p> <p>0 0 1 VID4-VID0 are routed from GPIO11-13, GPIO16, GPIO17. Only CPU0 is supported.</p> <p>0 1 0 VID4-VID0 are routed from GPIO05, GPIO12-14, GPIO32 . Only CPU0 is supported.</p> <p>0 1 1 When CPU0 is selected: VID4-VID0 are routed from GPIO20-24; when CPU1 is selected: VID4-VID0 are routed from GPIO25-27, GPIO30, GPIO31</p> <p>1 0 0 VID4-VID0 are routed from GPIO11-13, GPIO16, GPIO17; processor select control is routed to GPIO14, which is configured as output.</p> <p>Other Reserved</p>
4	<p>SMI to IRQ2 Enable. This is a R/W bit.</p> <p>0: Disabled (default)</p> <p>1: Enabled</p>
3-2	Reserved
1-0	<p>Pin 128 Function Select. This is a R/W bit.</p> <p>Bits</p> <p>1 0 Function</p> <p>0 0 GPIO33 (default)</p> <p>0 1 FANIN2</p> <p>1 x Reserved</p>

2.8.7 SuperI/O Revision ID Register (SRID)

This register contains the identity number of the chip revision. SRID is incremented on each revision.

Location: Index 27h

Type: RO

2.0 Device Architecture and Configuration (Continued)

2.8.8 SuperI/O Configuration 8 Register (SIOCF8)

Location: Index 28h

Type: R/W

Bit	7	6	5	4	3	2	1	0
Name	VLM to $\overline{\text{SMI}}$ Enable	TMS to $\overline{\text{SMI}}$ Enable	$\overline{\text{CHASO}}$ to $\overline{\text{SMI}}$ Enable	Mouse IRQ to $\overline{\text{SMI}}$ Enable	KBD IRQ to $\overline{\text{SMI}}$ Enable	KBD P12 to $\overline{\text{SMI}}$ Enable	GPI to $\overline{\text{SMI}}$ Enable	$\overline{\text{WDO}}$ to $\overline{\text{SMI}}$ Enable
Reset	0	0	0	0	0	0	0	0

Bit	Description
7	VLM to $\overline{\text{SMI}}$ Enable 0: Disabled (default) 1: Enabled
6	TMS to $\overline{\text{SMI}}$ Enable 0: Disabled (default) 1: Enabled
5	$\overline{\text{CHASO}}$ to $\overline{\text{SMI}}$ Enable 0: Disabled (default) 1: Enabled:
4	Mouse IRQ to $\overline{\text{SMI}}$ Enable 0: Disabled (default) 1: Enabled
3	KBD IRQ to $\overline{\text{SMI}}$ Enable 0: Disabled (default) 1: Enabled
2	KBD P12 to $\overline{\text{SMI}}$ Enable 0: Disabled (default) 1: Enabled
1	GPI to $\overline{\text{SMI}}$ Enable 0: Disabled (default) 1: Enabled
0	$\overline{\text{WDO}}$ to $\overline{\text{SMI}}$ Enable 0: Disabled (default) 1: Enabled

2.0 Device Architecture and Configuration (Continued)

2.8.9 SuperI/O Configuration A Register (SIOCFA)

This is a battery-backed register.

Location: Index 2Ah

Type: Varies per bit

Bit	7	6	5	4	3	2	1	0
Name	 Pins 33-37 Function Select	 Pin 28 Function Select	 Pin 27 Function Select		 Pin 26 Function Select	 Pin 25 Function Select		 Pin 24 Function Select
Reset	Strap	0	0	0	0	0	0	0

Bit	Description																							
	Pins 33-37 Function Select. This is a RO bit. The function of the pin selected is determined during V_{SB} power-up by the PSLDC0.1 straps.0:PWBTOUT, PSON, PWBTIN, SLPS3, SLPS5 1: GPOS0, GPOS1, GPIS2, SLPS3, AVI0																							
6	Pin 28 Function Select. This is a R/W bit. 0: GPIOE5 (default at V_{PP} power-up reset) 1: CHASO																							
5-4	Pin 27 Function Select. This is a R/W bit. Bits 5 4 Function 0 0 GPIOE4 (default at V_{PP} power-up reset) 0 1 RING 1 0 ALARM Other Reserved																							
3	Pin 26 Function Select. This is a R/W bit. 0: GPIOE3 (default at V_{PP} power-up reset) 1: LED2																							
2-1	Pin 25 Function Select. This is a R/W bit. Bits 2 1 Function 0 0 GPIOE2 (default at V_{PP} power-up reset) 0 1 LED1 1 0 OTS2 (can be enabled only if OTS1 is enabled) Other Reserved																							
0	Pin 24 Function Select 0: GPIOE1 (default at V_{PP} power-up reset) 1: OTS1. $\overline{OTS1}$ functionality changes when OTS2 is enabled. The following table summarizes which OTS output is affected when an overtemperature is detected by any of the sources. A Y indicates that the pin is active for this condition; an N indicates that it is inactive. <table border="1" data-bbox="285 1673 866 1919"> <thead> <tr> <th rowspan="2">Source</th> <th>1 OTS Pin</th> <th colspan="2">2 OTS Pins</th> </tr> <tr> <th>$\overline{OTS1}$</th> <th>$\overline{OTS1}$</th> <th>OTS2</th> </tr> </thead> <tbody> <tr> <td>Remote 1</td> <td>Y</td> <td>Y</td> <td>N</td> </tr> <tr> <td>Remote 2</td> <td>Y</td> <td>N</td> <td>Y</td> </tr> <tr> <td>Local</td> <td>Y</td> <td>Y</td> <td>N</td> </tr> <tr> <td>VLM</td> <td>Y</td> <td>Y</td> <td>N</td> </tr> </tbody> </table>	Source	1 OTS Pin	2 OTS Pins		$\overline{OTS1}$	$\overline{OTS1}$	OTS2	Remote 1	Y	Y	N	Remote 2	Y	N	Y	Local	Y	Y	N	VLM	Y	Y	N
Source	1 OTS Pin		2 OTS Pins																					
	$\overline{OTS1}$	$\overline{OTS1}$	OTS2																					
Remote 1	Y	Y	N																					
Remote 2	Y	N	Y																					
Local	Y	Y	N																					
VLM	Y	Y	N																					

2.0 Device Architecture and Configuration (Continued)

2.8.10 SuperI/O Configuration B Register (SIOCFB)

This is a battery-backed register.

Location: Index 2Bh

Type: Varies per bit

Bit	7	6	5	4	3	2	1	0
Name	Reserved	Pins 47-49 Function Select	Intrusion Level	Intrusion Status	LED Mode Control		Pin 59 Function Select	Pin 58 Function Select
Reset	0	0	X	1	0	0	0	0

Bit	Description
7	Reserved
6	Pins 47-49 Function Select 0: Pins 47-49 enabled as D1N, D1P and D2N by the TMS (default) 1: Pins 47-49 enabled as TS1, TS2 and TS3 by the VLM. For further details, see the TMS Configuration register setting.
5	Intrusion Level. This is a RO bit, which reflects the value of pin 29 (CHASI), either 0 or 1.
4	Intrusion Status. Write 0 to this bit to clear it. 0: No intrusion 1: Intrusion detected (default at V _{PP} power-up reset)
3-2	LED Mode Control. This is a R/W bit. Bits 3 2 Function 0 0 Software mode (default at V _{PP} power-up reset) 0 1 Hardware mode 1 (default when power supply control is disabled by PSLDC0,1 straps) 1 0 Hardware mode 2 1 1 Reserved
1	Pin 59 Function Select. This is a R/W bit. 0: GPIE7 (default at V _{PP} power-up reset) 1: IRRX1
0	Pin 58 Function Select. This is a R/W bit. 0: GPIE6 (default at V _{PP} power-up reset) 1: IRRX2_IRSL0

2.0 Device Architecture and Configuration (Continued)

2.8.11 SuperI/O Configuration C Register (SIOCFC)

This is a battery-backed register.

Location: Index 2Ch

Type: R/W

Bit	7	6	5	4	3	2	1	0
Name	LED Configuration	Power LED Status in S4 or S5	LED2 Blink Rate			LED1 Blink Rate		
Reset	0	0	0	0	0	0	0	0

Bit	Description																																													
7	LED Configuration 0: One dual-colored LED (default at V_{PP} power-up reset) 1: Two LEDs																																													
6	Power LED Status in S4 or S5. This bit is active only when hardware mode 2 is selected (bits 2-3 in the SIOCFB register). 0: Turn off (default at V_{DD} power off) 1: Unchanged																																													
5-3	LED2 Blink Rate Bits <table border="1"> <thead> <tr> <th>5</th> <th>4</th> <th>3</th> <th>Rate (Hz)</th> <th>Duty Cycle</th> </tr> </thead> <tbody> <tr> <td>0</td> <td>0</td> <td>0</td> <td>Off</td> <td>Always low</td> </tr> <tr> <td>0</td> <td>0</td> <td>1</td> <td>0.25</td> <td>12.5%</td> </tr> <tr> <td>0</td> <td>1</td> <td>0</td> <td>0.5</td> <td>25%</td> </tr> <tr> <td>0</td> <td>1</td> <td>1</td> <td>1</td> <td>50%^{Note 1.}</td> </tr> <tr> <td>1</td> <td>0</td> <td>0</td> <td>2</td> <td>50%</td> </tr> <tr> <td>1</td> <td>0</td> <td>1</td> <td>3</td> <td>50%</td> </tr> <tr> <td>1</td> <td>1</td> <td>0</td> <td>4</td> <td>50%</td> </tr> <tr> <td>1</td> <td>1</td> <td>1</td> <td>On</td> <td>Always high (default at V_{PP} power-up reset)</td> </tr> </tbody> </table>	5	4	3	Rate (Hz)	Duty Cycle	0	0	0	Off	Always low	0	0	1	0.25	12.5%	0	1	0	0.5	25%	0	1	1	1	50% ^{Note 1.}	1	0	0	2	50%	1	0	1	3	50%	1	1	0	4	50%	1	1	1	On	Always high (default at V_{PP} power-up reset)
5	4	3	Rate (Hz)	Duty Cycle																																										
0	0	0	Off	Always low																																										
0	0	1	0.25	12.5%																																										
0	1	0	0.5	25%																																										
0	1	1	1	50% ^{Note 1.}																																										
1	0	0	2	50%																																										
1	0	1	3	50%																																										
1	1	0	4	50%																																										
1	1	1	On	Always high (default at V_{PP} power-up reset)																																										
2-0	LED1 Blink Rate Bits <table border="1"> <thead> <tr> <th>2</th> <th>1</th> <th>0</th> <th>Rate (Hz)</th> <th>Duty Cycle</th> </tr> </thead> <tbody> <tr> <td>0</td> <td>0</td> <td>0</td> <td>Off</td> <td>Always low (default at V_{PP} power-up reset)</td> </tr> <tr> <td>0</td> <td>0</td> <td>1</td> <td>0.25</td> <td>12.5%</td> </tr> <tr> <td>0</td> <td>1</td> <td>0</td> <td>0.5</td> <td>25%</td> </tr> <tr> <td>0</td> <td>1</td> <td>1</td> <td>1</td> <td>50%</td> </tr> <tr> <td>1</td> <td>0</td> <td>0</td> <td>2</td> <td>50%</td> </tr> <tr> <td>1</td> <td>0</td> <td>1</td> <td>3</td> <td>50%</td> </tr> <tr> <td>1</td> <td>1</td> <td>0</td> <td>4</td> <td>50%</td> </tr> <tr> <td>1</td> <td>1</td> <td>1</td> <td>On</td> <td>Always high</td> </tr> </tbody> </table>	2	1	0	Rate (Hz)	Duty Cycle	0	0	0	Off	Always low (default at V_{PP} power-up reset)	0	0	1	0.25	12.5%	0	1	0	0.5	25%	0	1	1	1	50%	1	0	0	2	50%	1	0	1	3	50%	1	1	0	4	50%	1	1	1	On	Always high
2	1	0	Rate (Hz)	Duty Cycle																																										
0	0	0	Off	Always low (default at V_{PP} power-up reset)																																										
0	0	1	0.25	12.5%																																										
0	1	0	0.5	25%																																										
0	1	1	1	50%																																										
1	0	0	2	50%																																										
1	0	1	3	50%																																										
1	1	0	4	50%																																										
1	1	1	On	Always high																																										

Note 1. When hardware mode 1 is selected, this rate will be set when V_{SB} is powered up or when V_{DD} becomes inactive while VSB is active.

2.0 Device Architecture and Configuration (Continued)

2.8.12 SuperI/O Configuration D Register (SIOCFD)

This is a battery-backed register.

Location: Index 2Dh

Type: Varies per bit

Bit	7	6	5	4	3	2	1	0
Name	LED Polarity Control	Last PSON State	PSON Polarity	Crowbar Timeout		Resume Last PSON State	Power Supply Off	Power Button Mode
Reset	0	0	Strap	1	1	0	0	0

Bit	Description
7	LED Polarity Control. This is a R/W bit. It determines if the LED outputs are active high or active low when they are lit. 0: Active high (default at V_{SB} power-up reset) 1: Active low
6	Last Power Supply On State. This is a RO bit. When operating in Legacy mode (bit 0 of this register is set to 0), this bit reflects the state of the PSON pin sampled during the last power failure (no V_{SB}), regardless of the polarity of PSON. 0: Off 1: On
5	Power Supply On Polarity. This is a RO bit. The polarity of PSON is determined during V_{SB} power-up by the PSONPOL strap.
4-3	Crowbar Timeout. This is a R/W bit. Bits 5 4 Value (Seconds) 0 0 0.5 to 0.75 0 1 1.0 to 1.25 1 0 1.25 to 1.5 1 1 2.0 to 2.25 (default at V_{PP} power-up reset)
2	Resume Last Power Supply On State. This is a R/W bit. When it is set to 1, PSON resumes its last state, sampled during the last power failure, after power returns. When this bit is set to 0, the PSON state is determined by the $SLPS3$ state. 0: $SLPS3$ (default at V_{PP} power-up reset) 1: Last PSON state. For correct operation, the system's ACPI controller must be configured to resume to OFF. This enables the power supply control logic to know the state of the chipset ACPI state machine after power failure (no V_{DD} and V_{SB}).
1	Power Supply Off. This is a R/W bit. It always returns 0 when read. When using Legacy mode (bit 0 is set to 0) and setting this bit to 1, this bit inactivates the PSON output, thereby shutting off the power supply. 0: No action (default at V_{PP} power-up reset) 1: Inactivate PSON in Legacy mode
0	Power Button Mode. This is a R/W bit. 0: Legacy (default at V_{SB} power-up reset) 1: ACPI

2.0 Device Architecture and Configuration (Continued)

2.9 FLOPPY DISK CONTROLLER (FDC) CONFIGURATION

2.9.1 General Description

The generic FDC is a standard FDC with a digital data separator, and is DP8473 and N82077 software compatible. The PC87366 FDC supports 14 of the 17 standard FDC signals described in the generic Floppy Disk Controller (FDC) chapter, including:

- FM and MFM modes are supported. To select either mode, set bit 6 of the first command byte when writing to/reading from a diskette, where:
0 = FM mode
1 = MFM mode
- A logic 1 is returned for all floating (TRI-STATE) FDC register bits upon LPC I/O read cycles.

Exceptions to standard FDC support include:

- Automatic media sense is not supported (MSEN0-1 pins are not implemented)
- DRATE1 is not supported.

Table 17 lists the FDC functional block registers.

Table 17. FDC Registers

Offset ^{Note 1}	Mnemonic	Register Name	Type
00h	SRA	Status A	RO
01h	SRB	Status B	RO
02h	DOR	Digital Output	R/W
03h	TDR	Tape Drive	R/W
04h	MSR	Main Status	R
	DSR	Data Rate Select	W
05h	FIFO	Data (FIFO)	R/W
06h		N/A	X
07h	DIR	Digital Input	R
	CCR	Configuration Control	W

Note 1. This is the 8-byte aligned FDC base address.

2.9.2 Logical Device 0 (FDC) Configuration

Table 18 lists the Configuration registers which affect the FDC. Only the last two registers (F0h and F1h) are described here. See Sections 2.2.3 and 2.2.4 for descriptions of the others.

Table 18. FDC Configuration Registers

Index	Configuration Register or Action	Type	Reset
30h	Activate. See also bit 0 of the SIOCF1 register and bit 0 of the SIOCF6 register.	R/W	00h
60h	Base Address MSB register. Bits 7-3 (for A15-11) are read only, 00000b.	R/W	03h
61h	Base Address LSB register. Bits 2 and 0 (for A2 and A0) are read only, 00b.	R/W	F2h
70h	Interrupt Number and Wake-Up on IRQ Enable register	R/W	06h
71h	Interrupt Type. Bit 1 is read/write; other bits are read only.	R/W	03h
74h	DMA Channel Select	R/W	02h
75h	Report no second DMA assignment	RO	04h
F0h	FDC Configuration register	R/W	24h
F1h	Drive ID register	R/W	00h

2.0 Device Architecture and Configuration (Continued)

2.9.3 FDC Configuration Register

This register is reset by hardware to 24h.

Location: Index F0h

Type: R/W

Bit	7	6	5	4	3	2	1	0
Name	Reserved	TDR Register Mode	DENSEL Polarity Control	Reserved	Write Protect	PC-AT or PS/2 Drive Mode Select	Reserved	TRI-STATE Control
Reset	0	0	1	0	0	1	0	0
Required	0			0				

Bit	Description
7	Reserved. Must be 0.
6	TDR Register Mode 0: PC-AT compatible drive mode; i.e., bits 7-2 of the TDR are 111111b (default) 1: Enhanced drive mode
5	DENSEL Polarity Control 0: Active low for 500 Kbps or 1 Mbps data rates 1: Active high for 500 Kbps or 1 Mbps data rates (default)
4	Reserved. Must be 0.
3	Write Protect. This bit allows forcing of write protect functionality by software. When set, writes to the floppy disk drive are disabled. This effect is identical to \overline{WP} when it is active. 0: Write protected according to \overline{WP} signal (default) 1: Write protected regardless of value of \overline{WP} signal
2	PC-AT or PS/2 Drive Mode Select 0: PS/2 drive mode 1: PC-AT drive mode (default)
1	Reserved
0	TRI-STATE Control. When enabled and the device is inactive, the logical device output pins are in TRI-STATE. 0: Disabled (default) 1: Enabled

2.0 Device Architecture and Configuration (Continued)

2.9.4 Drive ID Register

This read/write register is reset by hardware to 00h. This register controls bits 5 and 4 of the TDR register in the Enhanced mode.

Location: Index F1h

Type: R/W

Bit	7	6	5	4	3	2	1	0
Name	Reserved			Drive 1 ID		Drive 0 ID		
Reset	0	0	0	0	0	0	0	0

Bit	Description
7-4	Reserved
3-2	Drive 1 ID. When drive 1 is accessed, these bits are reflected on bits 5-4 of the TDR register, respectively.
1-0	Drive 0 ID. When drive 0 is accessed, these bits are reflected on bits 5-4 of the TDR register, respectively.

Usage Hints: Some BIOS implementations support automatic media sense FDDs, in which case bit 5 of the TDR register in the Enhanced mode is interpreted as valid media sense when it is cleared to 0. If drive 0 and/or drive 1 do not support automatic media sense, bits 1 and/or 3 of the Drive ID register should be set to 1 respectively (to indicate non-valid media sense) when the corresponding drive is selected and the Drive ID bit is reflected on bit 5 of the TDR register in the Enhanced mode.

2.0 Device Architecture and Configuration (Continued)

2.10 PARALLEL PORT CONFIGURATION

2.10.1 General Description

The PC87366 Parallel Port supports all IEEE1284 standard communication modes: Compatibility (known also as Standard or SPP), Bidirectional (known also as PS/2), FIFO, EPP (known also as Mode 4) and ECP (with an optional Extended ECP mode).

The Parallel Port includes two groups of runtime registers, as follows:

- A group of 21 registers at first level offset, sharing 14 entries. Three of this registers (at offsets 403h, 404h and 405h) are used only in the Extended ECP mode.
- A group of four registers, used only in the Extended ECP mode, accessed by a second level offset.

The desired mode is selected by the ECR runtime register (offset 402h). The selected mode determines which runtime registers are used and which address bits are used for the base address. See Tables 19 and 20 for a listing of all registers, their offset addresses, and the associated modes.

Table 19. Parallel Port Registers at First Level Offset

Offset	Mnemonic	Mode(s)	Type	Register Name
00h	DATAR	0,1	R/W	Data
	AFIFO	3	W	ECP FIFO (Address)
	DTR	4	R/W	Data (for EPP)
01h	DSR	0,1,2,3	RO	Status
	STR	4	RO	Status (for EPP)
02h	DCR	0,1,2,3	R/W	Control
	CTR	4	R/W	Control (for EPP)
03h	ADDR	4	R/W	EPP Address
04h	DATA0	4	R/W	EPP Data Port 0
05h	DATA1	4	R/W	EPP Data Port 1
06h	DATA2	4	R/W	EPP Data Port 2
07h	DATA3	4	R/W	EPP Data Port 3
400h	CFIFO	2	W	PP Data FIFO
	DFIFO	3	R/W	ECP Data FIFO
	TFIFO	6	R/W	Test FIFO
	CNFGA	7	RO	Configuration A
401h	CNFGB	7	RO	Configuration B
402h	ECR	0,1,2,3	R/W	Extended Control
403h	EIR ^{Note 1.}	0,1,2,3	R/W	Extended Index
404h	EDR ¹	0,1,2,3	R/W	Extended Data
405h	EAR ¹	0,1,2,3	R/W	Extended Auxiliary Status

Note 1. These registers are extended to the standard IEEE1284 registers. They are accessible only when enabled by bit 4 of the Parallel Port Configuration register (see Section 2.10.3).

Table 20. Parallel Port Registers at Second Level Offset

Offset	Mnemonic	Type	Register Name
00h	Control0	R/W	Extended Control 0
02h	Control2	R/W	Extended Control 1
04h	Control4	R/W	Extended Control 4
05h	PP Config0	R/W	Configuration 0

2.0 Device Architecture and Configuration (Continued)

2.10.2 Logical Device 1 (PP) Configuration

Table 21 lists the configuration registers which affect the Parallel Port. Only the last register (F0h) is described here. See Sections 2.2.3 and 2.2.4 for descriptions of the others.

Table 21. Parallel Port Configuration Registers

Index	Configuration Register or Action	Type	Reset
30h	Activate. See also bit 0 of the SIOCF1 register.	R/W	00h
60h	Base Address MSB register. Bits 7-3 (for A15-11) are read only, 00000b. Bit 2 (for A10) should be 0b.	R/W	02h
61h	Base Address LSB register. Bits 1 and 0 (A1 and A0) are read only, 00b. For ECP Mode 4 (EPP) or when using the Extended registers, bit 2 (A2) should also be 0b.	R/W	78h
70h	Interrupt Number and Wake-Up on IRQ Enable register	R/W	07h
71h	Interrupt Type Bits 7-2 are read only. Bit 1 is a read/write bit. Bit 0 is read only. It reflects the interrupt type dictated by the Parallel Port operation mode. This bit is set to 1 (level interrupt) in Extended Mode and cleared (edge interrupt) in all other modes.	R/W	02h
74h	DMA Channel Select	R/W	04h
75h	Report no second DMA assignment	RO	04h
F0h	Parallel Port Configuration register	R/W	F2h

2.10.3 Parallel Port Configuration Register

This register is reset by hardware to F2h.

Location: Index F0h

Type: R/W

Bit	7	6	5	4	3	2	1	0
Name	Reserved			Extended Register Access	Reserved		Power Mode Control	TRI-STATE Control
Reset	1	1	1	1	0	0	1	0
Required	1	1	1					

Bit	Description
7-5	Reserved. Must be 11.
4	Extended Register Access 0: Registers at base (address) + 403h, base + 404h and base + 405h are not accessible (reads and writes are ignored). 1: Registers at base (address) + 403h, base + 404h and base + 405h are accessible. This option supports run-time configuration within the Parallel Port address space.
3-2	Reserved
1	Power Mode Control. When the logical device is active: 0: Parallel port clock disabled. ECP modes and EPP time-out are not functional when the logical device is active. Registers are maintained. 1: Parallel port clock enabled. All operation modes are functional when the logical device is active (default).
0	TRI-STATE Control. When enabled and the device is inactive, the logical device output pins are in TRI-STATE. 0: Disabled (default) 1: Enabled

2.0 Device Architecture and Configuration (Continued)

2.11 SERIAL PORT 2 CONFIGURATION

2.11.1 General Description

Serial Port 2 includes IR functionality as described in the Serial Port 2 with IR chapter.

2.11.2 Logical Device 2 (SP2) Configuration

Table 22 lists the configuration registers which affect the Serial Port 2. Only the last register (F0h) is described here. See Sections 2.2.3 and 2.2.4 for descriptions of the others.

Table 22. Serial Port 2 Configuration Registers

Index	Configuration Register or Action	Type	Reset
30h	Activate. See also bit 0 of the SIOCF1 register and bit 2 of the SIOCF6 register.	R/W	00h
60h	Base Address MSB register. Bits 7-3 (for A15-11) are read only, 00000b.	R/W	02h
61h	Base Address LSB register. Bit 2-0 (for A2-0) are read only, 000b.	R/W	F8h
70h	Interrupt Number and Wake-Up on IRQ Enable register	R/W	03h
71h	Interrupt Type. Bit 1 is R/W; other bits are read only.	R/W	03h
74h	DMA Channel Select 0 (RX_DMA)	R/W	04h
75h	DMA Channel Select 1 (TX_DMA)	R/W	04h
F0h	Serial Port 2 Configuration register	R/W	02h

2.11.3 Serial Port 2 Configuration Register

This register is reset by hardware to 02h.

Location: Index F0h

Type: R/W

Bit	7	6	5	4	3	2	1	0
Name	Bank Select Enable	Reserved				Busy Indicator	Power Mode Control	TRI-STATE Control
Reset	0	0	0	0	0	0	1	0

Bit	Description
7	Bank Select Enable. Enables bank switching for Serial Port 2. 0: All attempts to access the extended registers in Serial Port 2 are ignored (default). 1: Enables bank switching for Serial Port 2.
6-3	Reserved
2	Busy Indicator. This read only bit can be used by power management software to decide when to power-down the Serial Port 2 logical device. 0: No transfer in progress (default). 1: Transfer in progress.
1	Power Mode Control. When the logical device is active in: 0: Low power mode Serial Port 2 Clock disabled. The output signals are set to their default states. The \overline{RI} input signal can be programmed to generate an interrupt. Registers are maintained. (Unlike Active bit in Index 30 that also prevents access to Serial Port 2 registers.) 1: Normal power mode Serial Port 2 clock enabled. Serial Port 2 is functional when the logical device is active (default).
0	TRI-STATE Control. When enabled and the device is inactive, the logical device output pins are in TRI-STATE. One exception is the IRTX pin, which is driven to 0 when Serial Port 2 is inactive and is not affected by this bit. 0: Disabled (default) 1: Enabled

2.0 Device Architecture and Configuration (Continued)

2.12 SERIAL PORT 1 CONFIGURATION

2.12.1 Logical Device 3 (SP1) Configuration

Table 23 lists the configuration registers which affect the Serial Port 2. Only the last register (F0h) is described here. See Sections 2.2.3 and 2.2.4 for descriptions of the others.

Table 23. Serial Port 1 Configuration Registers

Index	Configuration Register or Action	Type	Reset
30h	Activate. See also bit 0 of the SIOCF1 register and bit 3 of the SIOCF6 register.	R/W	00h
60h	Base Address MSB register. Bits 7-3 (for A15-11) are read only, 00000b.	R/W	03h
61h	Base Address LSB register. Bit 2-0 (for A2-0) are read only, 000b.	R/W	F8h
70h	Interrupt Number and Wake-Up on IRQ Enable register	R/W	04h
71h	Interrupt Type. Bit 1 is R/W; other bits are read only.	R/W	03h
74h	Report no DMA Assignment	RO	04h
75h	Report no DMA Assignment	RO	04h
F0h	Serial Port 1 Configuration register	R/W	02h

2.12.2 Serial Port 1 Configuration Register

This register is reset by hardware to 02h.

Location: Index F0h

Type: R/W

Bit	7	6	5	4	3	2	1	0	
Name	Bank Select Enable	Reserved				Busy Indicator	Power Mode Control	TRI-STATE Control	
Reset	0	0	0	0	0	0	1	0	

Bit	Description
7	Bank Select Enable. Enables bank switching for Serial Port 1. 0: Disabled (default). 1: Enabled
6-3	Reserved
2	Busy Indicator. This read only bit can be used by power management software to decide when to power-down the Serial Port 1 logical device. 0: No transfer in progress (default). 1: Transfer in progress.
1	Power Mode Control. When the logical device is active in: 0: Low power mode Serial Port 1 Clock disabled. The output signals are set to their default states. The \overline{RI} input signal can be programmed to generate an interrupt. Registers are maintained. (Unlike Active bit in Index 30 that also prevents access to Serial Port 1 registers.) 1: Normal power mode Serial Port 1 clock enabled. Serial Port 1 is functional when the logical device is active (default).
0	TRI-STATE Control. When enabled and the device is inactive, the logical device output pins are in TRI-STATE. 0: Disabled (default) 1: Enabled

2.0 Device Architecture and Configuration (Continued)

2.13 SYSTEM WAKE-UP CONTROL (SWC) CONFIGURATION

2.13.1 Logical Device 4 (SWC) Configuration

Table 24 lists the configuration registers which affect the SWC. See Sections 2.2.3 and 2.2.4 for a detailed description of these registers.

Table 24. System Wake-Up Control (SWC) Configuration Registers

Index	Configuration Register or Action	Type	Reset
30h	Activate. When bit 0 is cleared, the registers of this logical device are not accessible. ^{Note 1.}	R/W	00h
60h	Base Address MSB register	R/W	00h
61h	Base Address LSB register. Bits 4-0 (for A4-0) are read only, 00000b.	R/W	00h
70h	Interrupt Number	R/W	00h
71h	Interrupt Type. Bit 1 is read/write. Other bits are read only.	R/W	03h
74h	Report no DMA assignment	RO	04h
75h	Report no DMA assignment	RO	04h

Note 1. The logical device registers are maintained, and all wake-up detection mechanisms are functional.

2.0 Device Architecture and Configuration (Continued)

2.14 KEYBOARD AND MOUSE CONTROLLER (KBC) CONFIGURATION

2.14.1 General Description

The KBC is implemented physically as a single hardware module and houses two separate logical devices: a Mouse controller (Logical Device 5) and a Keyboard controller (Logical Device 6).

The hardware KBC module is integrated to provide the following pin functions: P12, P16, P17, KBRST (P20), GA20 (P21), KBDAT, KBCLK, MDAT, and MCLK. KBRST and GA20 are implemented as bi-directional, open-drain pins. The Keyboard and Mouse interfaces are implemented as bi-directional, open-drain pins. Their internal connections are shown in Figure 5.

P10, P11, P13-P15, P22-P27 of the KBC core are not available on dedicated pins; neither are T0 and T1. P10, P11, P22, P23, P26, P27, T0 and T1 are used to implement the Keyboard and Mouse interface.

Internal pull-ups are implemented only on P12, P16 and P17.

The KBC executes a program fetched from an on-chip 2Kbyte ROM. The code programmed in this ROM is user-customizable. The KBC has two interrupt request signals: one for the Keyboard and one for the Mouse. The interrupt requests are implemented using ports P24 and P25 of the KBC core. The interrupt requests are controlled exclusively by the KBC firmware, except for the type and number, which are affected by configuration registers (see Section 2.14.2.5).

The interrupt requests are implemented as bi-directional signals. When an I/O port is read, all unused bits return the value latched in the output registers of the ports.

For KBC firmware that implements interrupt-on-OBF schemes, it is recommended to implement it as follows:

1. Put the data in DBBOUT.
2. Set the appropriate port bit to issue an interrupt request.

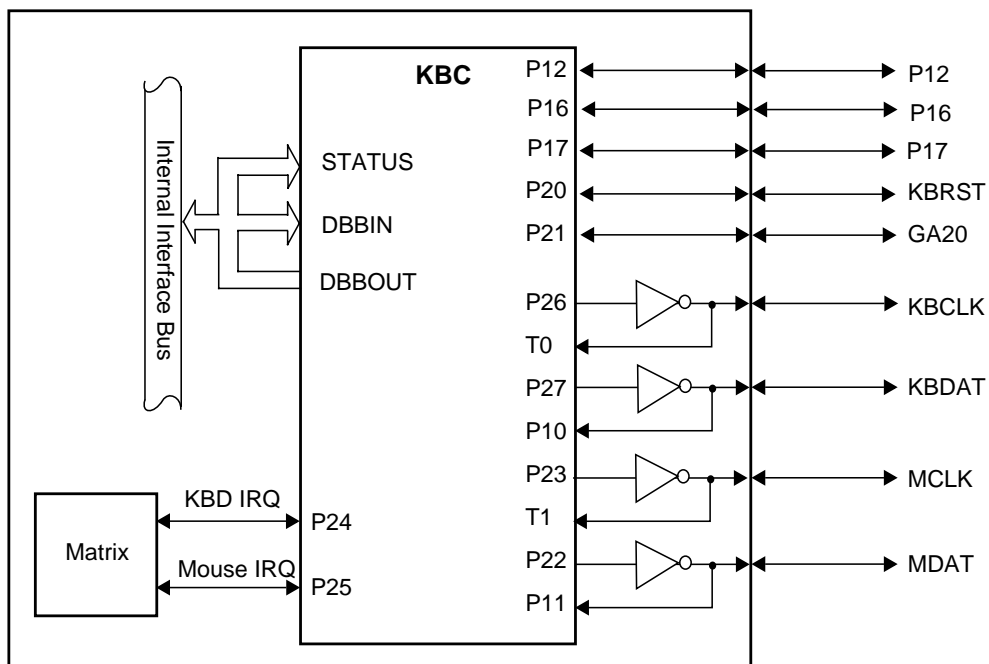

Figure 5. Keyboard and Mouse Interfaces

2.0 Device Architecture and Configuration (Continued)

2.14.2 Logical Devices 5 and 6 (Mouse and Keyboard) Configuration

Tables 25 and 26 list the configuration registers which affect the Mouse and the Keyboard respectively. Only the last register (F0h) is described here. See Sections 2.2.3 and 2.2.4 for descriptions of the others.

Table 25. Mouse Configuration Registers

Index	Mouse Configuration Register or Action	Type	Reset
30h	Activate. See also bit 0 of the SIOCF1. When the Mouse of the KBC is inactive, the IRQ selected by the Mouse Interrupt Number and Wake-Up on IRQ Enable register (index 70h) is not asserted. This register has no effect on host KBC commands handling the PS/2 Mouse.	R/W	00h
70h	Mouse Interrupt Number and Wake-Up on IRQ Enable register	R/W	0Ch
71h	Mouse Interrupt Type. Bits 1,0 are read/write; other bits are read only.	R/W	02h
74h	Report no DMA assignment	RO	04h
75h	Report no DMA assignment	RO	04h

Table 26. Keyboard Configuration Registers

Index	Keyboard Configuration Register or Action	Type	Reset
30h	Activate. See also bit 0 of the SIOCF1.	R/W	01h
60h	Base Address MSB register. Bits 7-3 (for A15-11) are read only, 00000b.	R/W	00h
61h	Base Address LSB register. Bits 2-0 are read only 000b.	R/W	60h
62h	Command Base Address MSB register. Bits 7-3 (for A15-11) are read only, 00000b.	R/W	00h
63h	Command Base Address LSB. Bits 2-0 are read only 100b.	R/W	64h
70h	KBD Interrupt Number and Wake-Up on IRQ Enable register	R/W	01h
71h	KBD Interrupt Type. Bits 1,0 are read/write; others are read only.	R/W	02h
74h	Report no DMA assignment	RO	04h
75h	Report no DMA assignment	RO	04h
F0h	KBC Configuration register	R/W	40h

2.0 Device Architecture and Configuration (Continued)

2.14.3 KBC Configuration Register

This register is reset by hardware to 40h.

Location: Index F0h

Type: R/W

Bit	7	6	5	4	3	2	1	0
Name	KBC Clock Source		Reserved					TRI-STATE Control
Reset	0	1	0	0	0	0	0	0
Required						0		

Bit	Description															
7-6	<p>KBC Clock Source. The clock source can be changed only when the KBC is inactive (disabled).</p> <p>Bits</p> <table border="1"> <thead> <tr> <th>7</th> <th>6</th> <th>Source</th> </tr> </thead> <tbody> <tr> <td>0</td> <td>0</td> <td>8 MHz</td> </tr> <tr> <td>0</td> <td>1</td> <td>12 MHz (default)</td> </tr> <tr> <td>1</td> <td>0</td> <td>16 MHz</td> </tr> <tr> <td>1</td> <td>1</td> <td>Reserved</td> </tr> </tbody> </table>	7	6	Source	0	0	8 MHz	0	1	12 MHz (default)	1	0	16 MHz	1	1	Reserved
7	6	Source														
0	0	8 MHz														
0	1	12 MHz (default)														
1	0	16 MHz														
1	1	Reserved														
5-1	Reserved															
0	<p>TRI-STATE Control. If KBD is inactive (disabled) when this bit is set, the KBD pins (KBCLK and KBDAT) are in TRI-STATE. If Mouse is inactive (disabled) when this bit is set, the Mouse pins (MCLK and MDAT) are in TRI-STATE.</p> <p>0: Disabled (default)</p> <p>1: Enabled</p>															

Usage Hints:

1. To change the clock frequency of the KBC, perform the following:
 - a. Disable the KBC logical devices.
 - b. Change the frequency setting.
 - c. Enable the KBC logical devices.

2.0 Device Architecture and Configuration (Continued)

2.15 GENERAL-PURPOSE INPUT/OUTPUT (GPIO) PORTS CONFIGURATION

2.15.1 General Description

The GPIO functional block includes 29 pins, arranged in three 8-bit ports (ports 0, 1 and 2) and one 5-bit port (port 3). All pins in port 0 are I/O, and have full event detection capability, enabling them to trigger the assertion of IRQ, SMI and PWUREQ signals. With the exception of bit 5 which is output only, port 1 pins are also I/O with full event detection capability. Pins in ports 2 and 3 are I/O, but none of them has event detection capability. The sixteen runtime registers associated with the five ports are arranged in the GPIO address space as shown in Table 27. The GPIO base address is 16-byte aligned. Address bits 3-0 are used to indicate the register offset.

Table 27. Runtime Registers in GPIO Address Space

Offset	Mnemonic	Register Name	Port	Type
00h	GPDO0	GPIO Data Out 0	0	R/W
01h	GPDI0	GPIO Data In 0		RO
02h	GPEVEN0	GPIO Event Enable 0		R/W
03h	GPEVST0	GPIO Event Status 0		R/W1C
04h	GPDO1	GPIO Data Out 1	1	R/W
05h	GPDI1	GPIO Data In 1		RO
06h	GPEVEN1	GPIO Event Enable 1		R/W
07h	GPEVST1	GPIO Event Status 1		R/W1C
08h	GPDO2	Data Out 2	2	R/W
09h	GPDI2	Data In 2		RO
0Ah	GPDO3	Data Out 3	3	R/W
0Bh	GPDI3	Data In 3		RO

2.15.2 Implementation

The standard GPIO port with event detection capability (such as ports 0, 1 and 4) has four runtime registers. Each pin is associated with a GPIO Pin Configuration register that includes seven configuration bits. Ports 2 and 3 are non-standard ports that do not support event detection, and therefore differ from the generic model as follows:

- They each have two runtime registers for basic functionality: GPDO2/3 and GPDI2/3. Event detection registers GPEVEN2/3 and GPEVST2/3 are not available.
- Only bits 3-0 are implemented in the GPIO Pin Configuration registers of ports 2 and 3. Bits 6-4, associated with the event detection functionality, are reserved.

2.0 Device Architecture and Configuration (Continued)

2.15.3 Logical Device 7 (GPIO) Configuration

Table 28 lists the configuration registers which affect the GPIO. Only the last three registers (F0h - F2h) are described here. See Sections 2.2.3 and 2.2.4 for a detailed description of the others.

Table 28. GPIO Configuration Register

Index	Configuration Register or Action	Type	Reset
30h	Activate. See also bit 7 of the SIOCF1 register.	R/W	00h
60h	Base Address MSB register	R/W	00h
61h	Base Address LSB register. Bits 3-0 (for A3-0) are read only, 0000b.	R/W	00h
70h	Interrupt Number	R/W	00h
71h	Interrupt Type. Bit 1 is read/write. Other bits are read only.	R/W	03h
74h	Report no DMA assignment	RO	04h
75h	Report no DMA assignment	RO	04h
F0h	GPIO Pin Select register	R/W	00h
F1h	GPIO Pin Configuration register	R/W	00h
F2h	GPIO Pin Event Routing register	R/W	00h

Figure shows the organization of these registers.

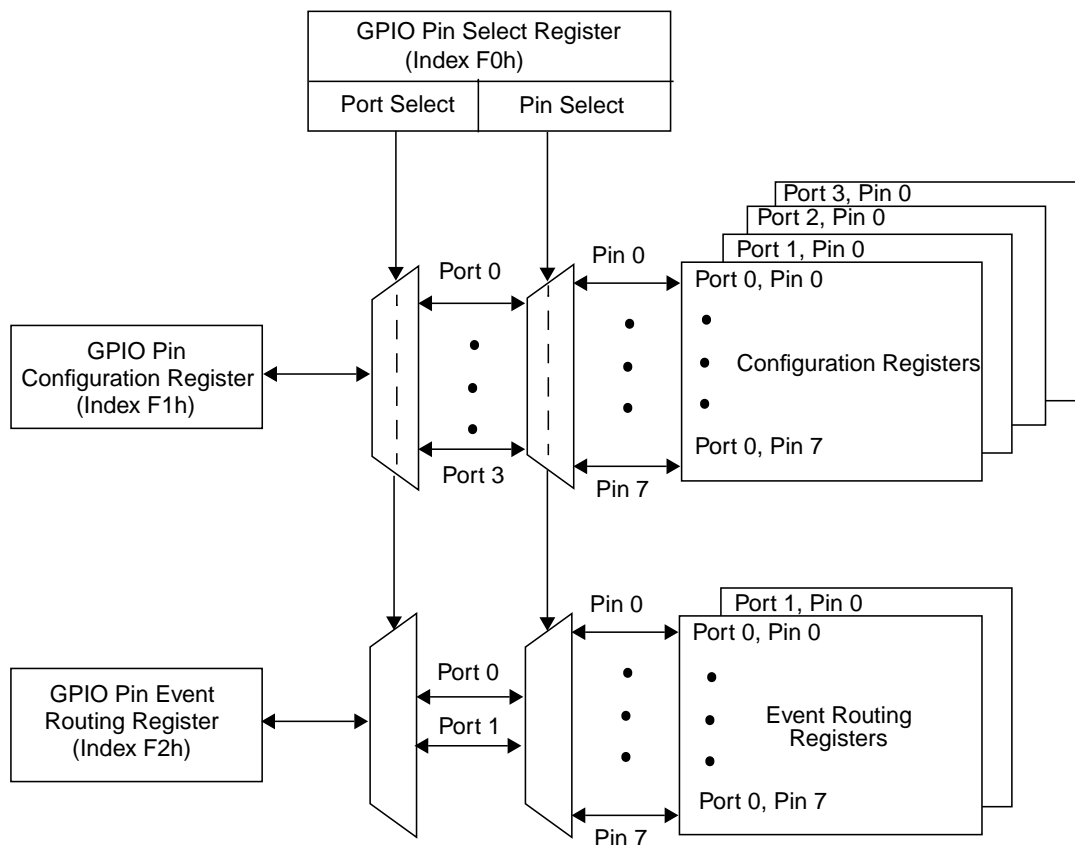

Figure 6. Organization of GPIO Pin Registers

2.0 Device Architecture and Configuration (Continued)

2.15.4 GPIO Pin Select Register

This register selects the GPIO pin (port number and bit number) to be configured (i.e., which register is accessed via the GPIO Pin Configuration register). It is reset by hardware to 00h.

Location: Index F0h

Type: R/W

Bit	7	6	5	4	3	2	1	0
Name	Reserved	Port Select			Reserved	Pin Select		
Reset	0	0	0	0	0	0	0	0

Bit	Description
7	Reserved
6-4	Port Select. These bits select the GPIO port to be configured: 000: Port 0 (default) 001, 010, 011: Binary value of port numbers 1-3 respectively. All other values are reserved.
3	Reserved
2-0	Pin Select. These bits select the GPIO pin to be configured in the selected port: 000, 001, ... 111: Binary value of the pin number, 0, 1, ... 7 respectively (default=0)

2.0 Device Architecture and Configuration (Continued)

2.15.5 GPIO Pin Configuration Register

This register reflects, for both read and write, the register currently selected by the GPIO Pin Select register. All the GPIO Pin registers that are accessed via this register have a common bit structure, as shown below. This register is reset by hardware to 44h, except for ports 2 and 3, that are reset to 04h.

Location: Index F1h

Type: R/W

Ports: 0 and 1 (with event detection capability)

Bit	7	6	5	4	3	2	1	0
Name	Reserved	Event Debounce Enable	Event Polarity	Event Type	Lock	Pull-Up Control	Output Type	Output Enable
Reset	0	1	0	0	0	1	0	0

Ports 2 and 3 (without event detection capability)

Bit	7	6	5	4	3	2	1	0
Name	Reserved				Lock	Pull-Up Control	Output Type	Output Enable
Reset	0	0	0	0	0	1	0	0

Bit	Description
7	Reserved
6	Event Debounce Enable. (Ports 0 and 1 with event detection capability). Enables transferring the signal only after a predetermined debouncing period of time. 0: Disabled 1: Enabled (default) Reserved. (Ports 2 and 3). Always 0.
5	Event Polarity. (Ports 0 and 1 with event detection capability). This bit defines the polarity of the signal that issues an interrupt from the corresponding GPIO pin (falling/low or rising/high). 0: Falling edge or low level input (default) 1: Rising edge or high level input Reserved. (Ports 2 and 3). Always 0.
4	Event Type. (Ports 0 and 1 with event detection capability). This bit defines the type of the signal that issues an interrupt from the corresponding GPIO pin (edge or level). 0: Edge input (default) 1: Level input Reserved. (Ports 2 and 3). Always 0.
3	Lock. This bit locks the corresponding GPIO pin. Once this bit is set to 1 by software, it can only be cleared to 0 by system reset or power-off. Pin multiplexing is functional until the Multiplexing Lock bit is 1 (bit 7 of SuperI/O Configuration 3 register, SIOCF3). 0: No effect (default) 1: Direction, output type, pull-up and output value locked
2	Pull-Up Control. This bit is used to enable/disable the internal pull-up capability of the corresponding GPIO pin. It supports open-drain output signals with internal pull-ups and TTL input signals 0: Disabled 1: Enabled (default)
1	Output Type. This bit controls the output buffer type (open-drain or push-pull) of the corresponding GPIO pin. 0: Open-drain (default) 1: Push-pull
0	Output Enable. This bit indicates the GPIO pin output state. It has no effect on the input path. 0: TRI-STATE (default) 1: Output enabled

2.0 Device Architecture and Configuration (Continued)

2.15.6 GPIO Event Routing Register

This register enables the routing of the GPIO event to IRQ, $\overline{\text{SMI}}$ and/or $\overline{\text{PWUREQ}}$ signals. It is implemented only for ports 0,1 and 4 which have event detection capability. This register is reset by hardware to 00h.

Location: Index F2h

Type: R/W

Bit	7	6	5	4	3	2	1	0
Name	Reserved					Enable $\overline{\text{PWUREQ}}$ Routing	Enable $\overline{\text{SMI}}$ Routing	Enable IRQ Routing
Reset	0	0	0	0	0	0	0	1

Bit	Description
7-3	Reserved
2	Enable $\overline{\text{PWUREQ}}$ Routing 0: Disabled (default) 1: Enabled
1	Enable $\overline{\text{SMI}}$ Routing 0: Disabled (default) 1: Enabled
0	Enable IRQ Routing 0: Disabled 1: Enabled (default)

2.0 Device Architecture and Configuration (Continued)

2.16 ACCESS.BUS INTERFACE (ACB) CONFIGURATION

2.16.1 General Description

The ACB is a two-wire synchronous serial interface compatible with the ACCESS.bus physical layer. The ACB uses a 24 MHz internal clock.

The six runtime registers are shown below.

Table 29. ACB Runtime Registers

Offset	Mnemonic	Register Name	Type
00h	ACBSDA	ACB Serial Data	R/W
01h	ACBST	ACB Status	Varies per bit
02h	ACBCST	ACB Control Status	Varies per bit
03h	ACBCTL1	ACB Control 1	R/W
04h	ACBADDR	ACB Own Address	R/W
05h	ACBCTL2	ACB Control 2	R/W

2.16.2 Logical Device 8 (ACB) Configuration

Table 30 lists the configuration registers which affect the ACB. Only the last register (F0h) is described here. See Sections 2.2.3 and 2.2.4 for a detailed description of the others.

Table 30. ACB Configuration Registers

Index	Configuration Register or Action	Type	Reset
30h	Activate. See also bit 0 of the SIOCF1 register.	R/W	00h
60h	Base Address MSB register	R/W	00h
61h	Base Address LSB register. Bits 2-0 (for A2-0) are read only, 000b.	R/W	00h
70h	Interrupt Number and Wake-Up on IRQ Enable register	R/W	00h
71h	Interrupt Type. Bit 1 is read/write. Other bits are read only.	R/W	03h
74h	Report no DMA assignment	RO	04h
75h	Report no DMA assignment	RO	04h
F0h	ACB Configuration register	R/W	00h

2.0 Device Architecture and Configuration (Continued)

2.16.3 ACB Configuration Register

This register is reset by hardware to 00h.

Location: Index F0h

Type: R/W

Bit	7	6	5	4	3	2	1	0
Name	Reserved					Internal Pull-Up Enable	Reserved	
Reset	0	0	0	0	0	0	0	0

Bit	Description
7-3	Reserved
2	Internal Pull-Up Enable 0: No internal pull-up resistors on SCL and SDA (default) 1: Internal pull-up resistors on SCL and SDA
1-0	Reserved

2.0 Device Architecture and Configuration (Continued)

2.17 FAN SPEED CONTROL AND MONITOR (FSCM) CONFIGURATION

2.17.1 General Description

This module includes three Fan Speed Control units and three Fan Speed Monitor units. The 15 runtime registers of the six functional blocks are arranged in the address space shown in Table 31. The base address is 16-byte aligned. Address bits 0-3 are used to indicate the register offset.

Table 31. Runtime Registers in FSCM Address Space

Offset	Mnemonic	Register Name	Function
00h	FCPSR0	Fan Control 0 Pre-Scale	Fan Speed Control 0
01h	FCDCR0	Fan Control 0 Duty Cycle	
02h	FCPSR1	Fan Control 1 Pre-Scale	Fan Speed Control 1
03h	FCDCR1	Fan Control 1 Duty Cycle	
04h	FCPSR2	Fan Control 2 Pre-Scale	Fan Speed Control 2
05h	FCDCR2	Fan Control 2 Duty Cycle	
06h	FMTHR0	Fan Monitor 0 Threshold	Fan Speed Monitor 0
07h	FMSPR0	Fan Monitor 0 Speed	
08h	FMCSR0	Fan Monitor 0 Control & Status	
09h	FMTHR1	Fan Monitor 1 Threshold	Fan Speed Monitor 1
0Ah	FMSPR1	Fan Monitor 1 Speed	
0Bh	FMCSR1	Fan Monitor 1 Control & Status	
0Ch	FMTHR2	Fan Monitor 2 Threshold	Fan Speed Monitor 2
0Dh	FMSPR2	Fan Monitor 2 Speed	
0Eh	FMCSR2	Fan Monitor 2 Control & Status	
0Fh	Reserved		

2.17.2 Logical Device 9 (FSCM) Configuration

Table 32 lists the configuration registers which affect the Fan Speed Controls and the Fan Speed Monitors. Only the last one (F0h) is described here. See Sections 2.2.3 and 2.2.4 for a detailed description of the others.

Table 32. FSCM Configuration Registers

Index	Configuration Register or Action	Type	Reset
30h	Activate. See also bit 0 of the SIOCF1 register.	R/W	00h
60h	Base Address MSB register	R/W	00h
61h	Base Address LSB register. Bit 3-0 (for A3-0) are read only, 0000b.	R/W	00h
70h	Interrupt Number and Wake-Up on IRQ Enable register	R/W	00h
71h	Interrupt Type. Bit 1 is read/write. Other bits are read only.	R/W	03h
74h	Report no DMA assignment	RO	04h
75h	Report no DMA assignment	RO	04h
F0h	Fan Speed Control and Monitor Configuration 1 register	R/W	00h
F1h	Fan Speed Control and Monitor Configuration 2 register	R/W	00h
F2h	Fan Speed Control OTS Configuration register	R/W	00h

2.0 Device Architecture and Configuration (Continued)

2.17.3 Fan Speed Control and Monitor Configuration 1 Register

This register is reset by hardware to 00h.

Location: Index F0h

Type: R/W

Bit	7	6	5	4	3	2	1	0
Name	Fan Speed Invert 1 Enable	Fan Speed Control 1 Enable	Fan Speed Monitor 1 Enable	Fan Speed Invert 0 Enable	Fan Speed Control 0 Enable	Fan Speed Monitor 0 Enable	Reserved	TRI-STATE Control
Reset	0	0	0	0	0	0	0	0

Bit	Description
7	Fan Speed Invert 1 Enable 0: Disabled (default) 1: Enabled
6	Fan Speed Control 1 Enable 0: Disabled (default) 1: Enabled
5	Fan Speed Monitor 1 Enable 0: Disabled (default) 1: Enabled
4	Fan Speed Invert 0 Enable 0: Disabled (default) 1: Enabled
3	Fan Speed Control 0 Enable 0: Disabled (default) 1: Enabled
2	Fan Speed Monitor 0 Enable 0: Disabled (default) 1: Enabled
1	Reserved
0	TRI-STATE Control. When enabled and the device is inactive, the logical device output pins are in TRI-STATE. 0: Disabled (default) 1: Enabled

2.0 Device Architecture and Configuration (Continued)

2.17.4 Fan Speed Control and Monitor Configuration 2 Register

This register is reset by hardware to 00h.

Location: Index F1h

Type: R/W

Bit	7	6	5	4	3	2	1	0
Name	Reserved					Fan Speed Invert 2 Enable	Fan Speed Control 2 Enable	Fan Speed Monitor 2 Enable
Reset	0	0	0	0	0	0	0	0

Bit	Description
7-3	Reserved
2	Fan Speed Invert 2 Enable 0: Disabled (default) 1: Enabled
1	Fan Speed Control 2 Enable 0: Disabled (default) 1: Enabled
0	Fan Speed Monitor 2 Enable 0: Disabled (default) 1: Enabled

2.17.5 Fan Speed Control OTS Configuration Register

Location: Index F2h

Type: R/W

Bit	7	6	5	4	3	2	1	0
Name	Reserved					Fan 2 Enable on OTS	Fan 1 Enable on OTS	Fan 0 Enable on OTS
Reset	0	0	0	0	0	0	0	0

Bit	Description
7-3	Reserved
2	Fan 2 Enable on OTS. Enables fan 2 at 100% duty cycle when an OTS event becomes active. 0: Fan 2 operates as defined by the PWM mechanism 1: Fan 2 is forced to 100% duty cycle when the OTS output from any of the temperature measurement channels (TMS or VLM) becomes active.
1	Fan 1 Enable on OTS. Enables fan 1 at 100% duty cycle when an OTS event becomes active. 0: Fan 1 operates as defined by the PWM mechanism 1: Fan 1 is forced to 100% duty cycle when the OTS output from any of the temperature measurement channels (TMS or VLM) becomes active.
0	Fan 0 Enable on OTS. Enables fan 0 at 100% duty cycle when an OTS event becomes active. 0: Fan 0 operates as defined by the PWM mechanism 1: Fan 0 is forced to 100% duty cycle when the OTS output from any of the temperature measurement channels (TMS or VLM) becomes active.

2.0 Device Architecture and Configuration (Continued)

2.18 WATCHDOG TIMER (WDT) CONFIGURATION

2.18.1 Logical Device 10 (WDT) Configuration

Table 33 lists the configuration registers which affect the WATCHDOG Timer. Only the last register (F0h) is described here. See Sections 2.2.3 and 2.2.4 for a detailed description of the others.

Table 33. WDT Configuration Registers

Index	Configuration Register or Action	Type	Reset
30h	Activate. When bit 0 is cleared, the registers of this logical device are not accessible.	R/W	00h
60h	Base Address MSB register	R/W	00h
61h	Base Address LSB register. Bits 1 and 0 (for A1 and A0) are read only, 00b.	R/W	00h
70h	Interrupt Number (for routing the \overline{WDO} signal) and Wake-Up on IRQ Enable register.	R/W	00h
71h	Interrupt Type. Bit 1 is read/write. Other bits are read only.	R/W	03h
74h	Report no DMA assignment	RO	04h
75h	Report no DMA assignment	RO	04h
F0h	WATCHDOG Timer Configuration register	R/W	02h

2.18.2 WATCHDOG Timer Configuration Register

This register is reset by hardware to 02h.

Location: Index F0h

Type: R/W

Bit	7	6	5	4	3	2	1	0
Name	Reserved				Output Type	Internal Pull-Up Enable	Power Mode Control	TRI-STATE Control
Reset	0	0	0	0	0	0	1	0

Bit	Description
7-4	Reserved
3	Output Type. This bit controls the buffer type (open-drain or push-pull) of the \overline{WDO} pin. 0: Open-drain (default) 1: Push-pull
2	Internal Pull-Up Enable. This bit controls the internal pull-up resistor on the \overline{WDO} pin. 0: Disabled (default) 1: Enabled
1	Power Mode Control 0: Low power mode: WATCHDOG Timer clock disabled. \overline{WDO} output signal is set to 1. Registers are accessible and maintained (unlike Active bit in Index 30h that also prevents access to WATCHDOG Timer registers). 1: Normal power mode: WATCHDOG Timer clock enabled. WATCHDOG Timer is functional when the logical device is active (default).
0	TRI-STATE Control. When enabled and the device is inactive, the logical device output pins are in TRI-STATE. 0: Disabled (default) 1: Enabled

2.0 Device Architecture and Configuration (Continued)

2.19 GAME PORT (GMP) CONFIGURATION

2.19.1 Logical Device 11 (GMP) Configuration

Table 34 lists the configuration registers which affect the Game Port. Only the last register (F0h) is described here. See Sections 2.2.3 and 2.2.4 for a detailed description of the others.

Table 34. GMP Configuration Registers

Index	Configuration Register or Action	Type	Reset
30h	Activate. When bit 0 is cleared, the registers of this logical device are not accessible.	R/W	00h
60h	Base Address MSB register	R/W	02h
61h	Base Address LSB register. Bits 3-0 (for A3-A0) are read only, 0000b.	R/W	00h
70h	Interrupt Number and Wake-Up on IRQ Enable register.	R/W	00h
71h	Interrupt Type. Bit 1 is read/write. Other bits are read only.	R/W	03h
74h	Report no DMA assignment	RO	04h
75h	Report no DMA assignment	RO	04h
F0h	Game Port Configuration register	R/W	00h

2.19.2 Game Port Configuration Register

This register is reset by hardware to 00h.

Location: Index F0h

Type: R/W

Bit	7	6	5	4	3	2	1	0
Name	Reserved					Internal Pull-Up Enable	Reserved	
Reset	0	0	0	0	0	0	0	0

Bit	Description
7-3	Reserved
2	Internal Pull-Up Enable. When the GMP functions are selected, this bit controls the internal pull-up resistor on pins 119 (GPIO22/JOYABTN0), 120 (GPIO23/JOYABTN1), 123 (GPIO26/JOYBBTN0) and 124 (GPIO27/JOYBBTN1). 0: Disabled (default) 1: Enabled
1-0	Reserved

Usage Hint:

To operate GMP enhanced features, make sure to locate its base address within the LPC Wide Generic address range.

2.0 Device Architecture and Configuration (Continued)

2.20 MIDI PORT (MIDI) CONFIGURATION

2.20.1 Logical Device 12 (MIDI) Configuration

Table 34 lists the configuration registers which affect the MIDI Port. Only the last register (F0h) is described here. See Sections 2.2.3 and 2.2.4 for a detailed description of the others.

Table 35. MIDI Configuration Registers

Index	Configuration Register or Action	Type	Reset
30h	Activate. When bit 0 is cleared, the registers of this logical device are not accessible.	R/W	00h
60h	Base Address MSB register	R/W	03h
61h	Base Address LSB register. Bits 2-0 (for A2-A0) are read only, 000b.	R/W	30h
70h	Interrupt Number and wake-up on IRQ enable.	R/W	00h
71h	Interrupt Type. Bit 1 is read/write. Other bits are read only.	R/W	03h
74h	Report no DMA assignment	RO	04h
75h	Report no DMA assignment	RO	04h
F0h	MIDI Port Configuration register	R/W	00h

2.20.2 MIDI Port Configuration Register

This register is reset by hardware to 00h.

Location: Index F0h

Type: R/W

Bit	7	6	5	4	3	2	1	0
Name	Reserved					Internal Pull-Up Enable	Reserved	TRI-STATE Control
Reset	0	0	0	0	0	0	0	0

Bit	Description
7-3	Reserved
2	Internal Pull-Up Enable. This bit controls the internal pull-up resistor on pin 126 (GPIO31/MDRX). 0: Disabled (default) 1: Enabled
1	Reserved
0	TRI-STATE Control. When enabled and the device is inactive, the logical device output pins are in TRI-STATE. 0: Disabled (default) 1: Enabled

Usage Hint:

To operate MIDI enhanced features, make sure to locate its base address within the LPC Wide Generic address range.

2.0 Device Architecture and Configuration (Continued)

2.21 VOLTAGE LEVEL MONITOR (VLM) CONFIGURATION

2.21.1 Logical Device 13 (VLM) Configuration

Table 36 lists the configuration registers which affect the VLM. See Sections 2.2.3 and 2.2.4 for a detailed description of these registers.

Table 36. VLM Configuration Registers

Index	Configuration Register or Action	Type	Reset
30h	Activate. When bit 0 is cleared, the registers of this logical device are not accessible.	R/W	00h
60h	Base Address MSB register	R/W	00h
61h	Base Address LSB register. Bits 3-0 (for A3-0) are read only, 0000b.	R/W	00h
70h	Interrupt Number	R/W	00h
71h	Interrupt Type. Bit 1 is read/write. Other bits are read only.	R/W	03h
74h	Report no DMA assignment	RO	04h
75h	Report no DMA assignment	RO	04h

2.22 TEMPERATURE SENSOR (TMS) CONFIGURATION

2.22.1 Logical Device 14 (TMS) Configuration

Table 37 lists the configuration registers which affect the TMS. See Sections 2.2.3 and 2.2.4 for a detailed description of these registers. The \overline{OTS} , ALERT, IRQ and SMI signals are routed through the configuration module. \overline{OTS} is routed to a pin, IRQ and SMI are routed to a designated interrupt signal, and ALERT is not connected. When measuring temperature using thermistors that are connected to the VLM module., the \overline{OTS} , ALERT, SMI and IRQ signals are routed through the TMS configuration. Therefore, ensure that you set the TMS configuration registers (described in Table 37) and enable the TMS module whenever temperature measurement is in use. In the TMS or VLM module, enable the required source of IRQ, SMI and OTS signals via the configuration registers inside the module.

Table 37. TMS Configuration Registers

Index	Configuration Register or Action	Type	Reset
30h	Activate. When bit 0 is cleared, the registers of this logical device are not accessible.	R/W	00h
60h	Base Address MSB register	R/W	00h
61h	Base Address LSB register. Bits 3-0 (for A3-0) are read only, 0000b.	R/W	00h
70h	Interrupt Number	R/W	00h
71h	Interrupt Type. Bit 1 is read/write. Other bits are read only.	R/W	03h
74h	Report no DMA assignment	RO	04h
75h	Report no DMA assignment	RO	04h

3.0 System Wake-Up Control (SWC)

3.1 OVERVIEW

The SWC recognizes the following maskable system events:

- Modem ring ($\overline{RI1}$ and $\overline{RI2}$ pins)
- Telephone ring (\overline{RING} input pin)
- Keyboard activity or specific programmable key sequence
- Mouse activity or specific programmable sequence of clicks and movements
- Programmable Consumer Electronics IR (CEIR) address
- Wake-up on module IRQs for FDC, Parallel Port, Serial Ports 1 and 2, Mouse, KBC, ACB, Fan Speed Control and Monitor (FSCM) and WATCHDOG Timer (WDT), Game Port and MIDI Port
- Eight V_{SB} -powered, general-purpose input events (via GPIOE0-5 and GPIOE6-7)
- 15 V_{DD} -powered, GPIO-triggered events (via GPIO00-07, GPIO10-14, GPIO16-17)
- Software event.

The SWC notifies the device when any of these events occur by asserting one or more of the following output pins:

- Power-Up Request (\overline{PWUREQ})
- System Management Interrupt (\overline{SMI})
- Interrupt Request (via \overline{SERIRQ})
- Power Button ($\overline{PWBTOUT}$)

Figure 7 shows the block diagram of the SWC.

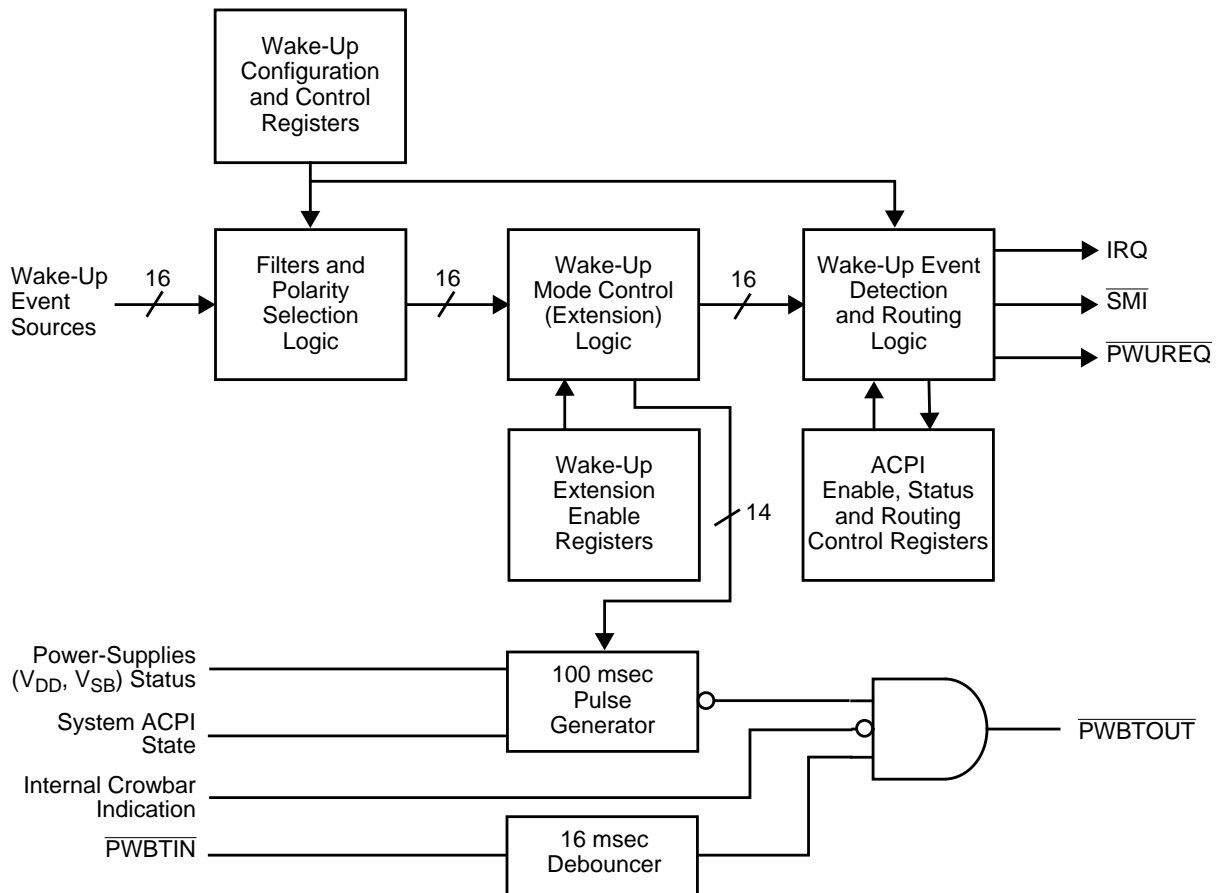

Figure 7. SWC Block Diagram

3.0 System Wake-Up Control (SWC) (Continued)

In addition to the event detection and system notification capabilities, the SWC operates several general-purpose I/O pins powered by V_{SB} . These pins can be used to perform various tasks while V_{SB} is present and V_{DD} is not.

3.2 FUNCTIONAL DESCRIPTION

The SWC monitors 16 system events or activities. Upon entering the SWC, the events pass through a filter (where applicable) and polarity adjustment logic. After filtering and polarity adjustment, each event enters the Wake-Up Mode Control (Extension) Logic which determines its effect during the various system power states. The Wake-Up Mode Control (Extension) Logic also controls the effect of each wake-up event on the power button output (PWBTOUT). See Figure 7 for an illustration of this mechanism.

After the wake-up mode is determined for all events, each one of them is fed into a dedicated detector that determines when this event is active, according to predetermined (either fixed or programmable) criteria. A set of dedicated registers is used to determine the wake-up criteria, including the CEIR address and the keyboard sequence.

Two Wake-Up Events Status registers (WK_STS n) hold a Status bit for each of the 16 events.

Six Wake-Up Events Routing Control register s (WK_EN n , WK_SMIEN n and WK_IRQEN n) hold three Routing Enable bits for each of the 16 events, to allow selective routing of these events to \overline{PWUREQ} , \overline{SMI} and/or the assigned SWC interrupt request (IRQ) channel.

Upon detection of any active event, the corresponding Status bit is set to 1, regardless of any Routing Enable bit. If both the Status bit and a Routing Enable bit corresponding to a specific event are set to 1 (no matter in what order), the output pin corresponding to that Routing Enable bit is asserted. The Status bit is deasserted by writing 1 to it. Writing 0 to a Routing Enable bit of an event prevents it from issuing the corresponding system notification, but does not affect the Status bit. Figure 8 show the routing scheme of detected wake-up events to the various means of system notification.

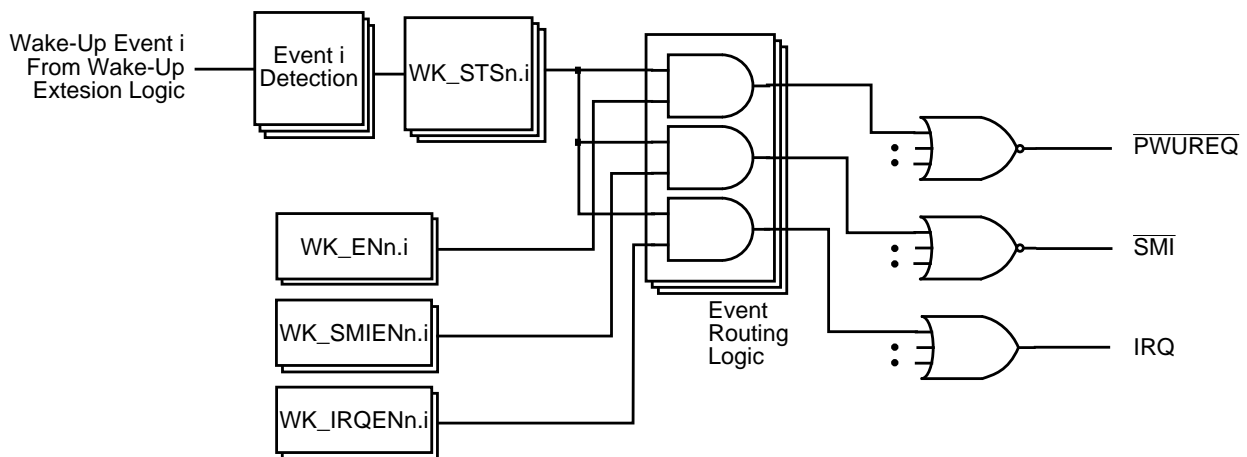

Figure 8. Wake-Up Events Routing Scheme

To enable the assertion of \overline{SMI} by detected wake-up events, it is necessary to either select the \overline{SMI} function on a device pin or route it to an interrupt request channel via the device's configuration registers.

3.0 System Wake-Up Control (SWC) (Continued)

Six Wake-Up Extension Enable registers (WK_X1EN0, 1, WK_X2EN0, 1, and WK_X3EN0 and 1) hold three configuration bits for each of the 16 events to allow selective routing of detected events to the Power Button (PWBTOUT) pulse generator, and to control the wake-up mode for each one of them. Figure 9 illustrates the Wake-Up Mode Control (Extension) mechanism.

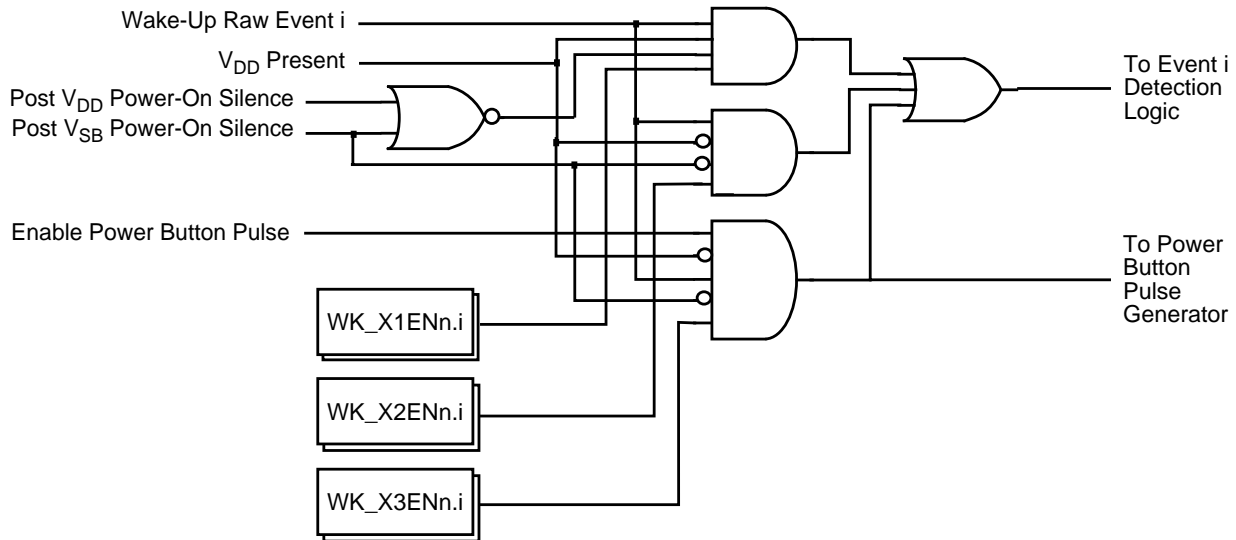

Figure 9. Wake-Up Mode Control (Extension) Mechanism

To operate the power button pulse generator, the PSLDC0,1 straps must be set to enable the Power Supply Control function (see Section 2.6). In addition, one of the following conditions must be satisfied:

- $\overline{\text{SLPS5}}$ is active (the system is in Sleep State 5), or
- Legacy Power Button is enabled, or
- Power Button operation in Sleep State 3 is enabled.

The two latter conditions are determined by device configuration registers. (Refer to the *Device Architecture and Configuration* chapter.)

In addition to monitoring various system events, the SWC operates several general-purpose I/O (GPIO) pins powered by V_{SB} . Four runtime data registers (SB_GPDOn and SB_GPDIn) hold a Data Out bit and a Data In bit for each V_{SB} powered GPIO pin. In addition, each GPIO pin has a dedicated configuration register that controls its characteristics. These configuration registers are accessed via a set of Standby GPIO Pin Select and Pin Configuration registers (SBGPSEL and SBGPCFG). For a detailed description of the V_{SB} powered GPIO pins, see Section 3.4.30.

The SWC logic is powered by V_{SB} . The SWC control and configuration registers are battery backed, powered by V_{PP} . The setup of the wake-up events, including programmable sequences, is retained throughout power failures (no V_{SB}) as long as the battery is connected. V_{PP} is taken from V_{SB} if V_{SB} is greater than the minimum (Min) value defined in the *Device Characteristics* chapter; otherwise, V_{BAT} is used as the V_{PP} source.

Hardware reset does not affect these registers. They are reset only by software reset or power-up of V_{PP} .

3.3 EVENT DETECTION

3.3.1 Modem Ring

High to low transitions on $\overline{\text{RI1}}$ or $\overline{\text{RI2}}$ indicate the detection of ring in external modem connected to Serial Port 1 or Serial Port 2, respectively, and can be used as wake-up events.

3.3.2 Telephone Ring

A telephone ring is detected by the SWC by processing the raw signal coming directly from the telephone line into the $\overline{\text{RING}}$ input pin. Detection of a pulse-train with a frequency higher than 16 Hz that lasts at least 0.19 sec, is used as a wake-up event.

3.0 System Wake-Up Control (SWC) (Continued)

The $\overline{\text{RING}}$ pulse-train detection is achieved by monitoring the falling edges on $\overline{\text{RING}}$ in time slots of 62.5 msec (a 16 Hz cycle). A positive detection occurs if falling edges of $\overline{\text{RING}}$ are detected in three consecutive time slots, following a time slot in which no $\overline{\text{RING}}$ falling edge is detected. This detection method guarantees the detection of a $\overline{\text{RING}}$ pulse-train with frequencies higher than 16 Hz. It filters out (does not detect) pulses of less than 10 Hz, and may detect pulses between 10 Hz to 16 Hz.

3.3.3 Keyboard and Mouse Activity

The detection of either any activity or a specific predetermined keyboard or mouse activity can be used as a wake-up event.

The keyboard wake-up detection can be programmed to detect:

- Any keystroke
- A specific programmable sequence of up to eight alphanumeric keystrokes
- Any programmable sequence of up to 8 bytes of data received from the keyboard.

The mouse wake-up detection can be programmed to detect either any mouse click or movement, or a specific programmable click (left or right) or double-clicks.

The keyboard or mouse event detection operates independently of the KBC (which is powered down with the rest of the system).

3.3.4 CEIR Address

A CEIR transmission received on an IRRX pin in a pre-selected standard (NEC, RCA or RC-5) is matched against a programmable CEIR address. Detection of matching can be used as a wake-up event.

Whenever an IR signal is detected, the receiver immediately enters the active state. When this happens, the receiver keeps sampling the IR input signal and generates a bit string where a logic 1 indicates an idle condition and a logic 0 indicates the presence of IR energy. The received bit string is de-serialized and assembled into 8-bit characters.

The expected CEIR protocol of the received signal should be configured through bits 5,4 at the CEIR Wake-Up Control register (see Section 3.4.22).

The CEIR Wake-Up Address register (IRWAD) holds the unique address to be compared with the address contained in the incoming CEIR message. If CEIR is enabled (bit 0 of the IRWCR register is 1) and an address match occurs, then the CEIR Event Status bit of the WK_STS0 register is set to 1 (see Section 3.4.2).

The CEIR Address Shift register holds the received address which is compared with the address contained in the IRWAD. The comparison is affected also by the CEIR Wake-Up Address Mask register (IRWAM) in which each bit determines whether to ignore the corresponding bit in the IRWAD.

If CEIR routing to interrupt request is enabled, the assigned SWC interrupt request may be used to indicate that a complete address has been received. To get this interrupt when the address is completely received, the IRWAM should be written with FFh. Once the interrupt is received, the value of the address can be read from the ADSR register.

Another parameter that is used to determine whether a CEIR signal is to be considered valid is the bit cell time width. There are four time ranges for the different protocols and carrier frequencies. Four pairs of registers define the low and high limits of each time range. (See Sections 3.4.29 through for more details regarding the recommended values for each protocol.)

The CEIR address detection operates independently of the serial port with the IR (which is powered down with the rest of the system).

3.3.5 Standby General-Purpose Input Events

A general-purpose event is defined as the detection of falling edge, rising edge, low level or high level on a specific signal. Each signal's event is configurable via software. GPIOE0-5 and GPIE6-7 may trigger a system notification by any of the means mentioned in Section 3.1.

A debouncer of 16 ms is enabled (default) on each event. It may be disabled by software.

3.3.6 GPIO-Triggered Events

A GPIO-triggered event is defined as the detection of falling edge, rising edge, low level or high level on a specific GPIO signal whose status bit is routed to $\overline{\text{PWUREQ}}$. Each signal's event is configurable via software in the GPIO logical device configuration registers. GPIO00-07, GPIO10-14, GPIO16-17 may trigger a system notification only by $\overline{\text{PWUREQ}}$. Other means of system notification triggered by GPIOs are available via the GPIO logical device configuration registers.

A debouncer of 16 ms is enabled (default) on each event. It may be disabled by software.

All GPIO pins are powered by V_{DD} , and therefore can cause an assertion of $\overline{\text{PWUREQ}}$ only when V_{DD} is present.

3.3.7 Software Event

A software event is defined as writing 1 to the Software Event Status bit of the WK_STS0 register. Once this bit is set to 1, it has the same effect as any other Event Status bit.

Since WK_STS0 is accessible only when V_{DD} is present, the Software Event can be activated only when V_{DD} is present.

3.0 System Wake-Up Control (SWC) (Continued)

3.3.8 Module IRQ Wake-Up Event

A module IRQ wake-up event is defined as the leading edge of the IRQ assertion of any of the following logical devices: FDC, Parallel Port, Serial Ports 1 and 2, Mouse, KBC, ACB, Fan Speed Control and Monitor (FSCM), Game Port and MIDI Port.

To enable the IRQ of a specific logical device to trigger a wake-up event, the associated Enable bit must be set to 1. This is bit 4 of the Interrupt Number and Wake-Up on IRQ Enable register, located at index 70h in the configuration space of the logical device (see Table 10 in *Device Architecture and Configuration* chapter). When this bit is set, any IRQ assertion of the corresponding logical device activates the module IRQ wake-up event. Therefore, the module IRQ wake-up event is a combination of all IRQ signals of the logical devices for which wake-up on IRQ is enabled.

When the event is detected as active, its associated Status bit (bit 7 of the WK0_STS register) is set to 1. If the associated Enable bit (bit 7 of the WK_EN0 register) is also set to 1, the \overline{PWUREQ} output is asserted. It remains asserted until the Status bit is cleared.

Since all the logical devices listed above are powered by V_{DD} , a module IRQ event can be activated only when V_{DD} is present.

3.4 SWC REGISTERS

The SWC registers are organized in four banks, all of which are battery-backed. The offsets are related to a base address that is determined by the SWC Base Address register in the device configuration registers. The lower 19 offsets are common to the four banks, while the upper offsets (13-1fh) are divided as follows:

- Bank 0 holds the Keyboard/Mouse Control registers.
- Bank 1 holds the CEIR Control registers.
- Bank 2 holds the Event Routing Configuration and Wake-Up Extension Control registers.
- Bank 3 holds the Standby General-Purpose I/O (GPIO) Pins Configuration registers.

The active bank is selected through the Configuration Bank Select field (bits 1-0) in the Wake-Up Configuration register (WK_CFG). See Section 3.4.6.

As a programming aid, the registers are described in this chapter according to the following functional groupings:

- General status, enable, configuration and routing registers
- Extension enable registers
- PS/2 event configuration registers
- CEIR event configuration registers
- Standby GPIO configuration and control registers

The following abbreviations are used to indicate the Register Type:

- R/W = Read/Write
- R = Read from a specific address returns the value of a specific register. Write to the same address is to a different register.
- W = Write
- RO = Read Only
- R/W1C = Read/Write 1 to Clear. Writing 1 to a bit clears it to 0. Writing 0 has no effect.

3.4.1 SWC Register Map

The following tables list the SWC registers. For the SWC register bitmap, see Section 3.5.

Table 38. Banks 0, 1, 2 and 3 - The Common Control and Status Register Map

Offset	Mnemonic	Register Name	Type	Section
00h	WK_STS0	Wake-Up Events Status 0	R/W1C	3.4.2
01h	WK_STS1	Wake-Up Events Status 1	R/W1C	3.4.3
02h	WK_EN0	Wake-Up Enable 0	R/W	3.4.4
03h	WK_EN1	Wake-Up Enable 1	R/W	3.4.5
04h	WK_CFG	Wake-Up Configuration	R/W	3.4.6
05h-07h	Reserved			
08h	SB_GPDO0	Standby GPIOE/GPIE Data Out 0	R/W	3.4.33

3.0 System Wake-Up Control (SWC) (Continued)

09h	SB_GPDI0	Standby GPIOE/GPIE Data In 0	RO	3.4.34
0Ah	SB_GPDO1	Standby GPOS Data Out 1	R/W	3.4.35
0Bh	SB_GPDI1	Standby GPIS Data In 1	RO	3.4.36
0Ch-12h	Reserved			

Table 39. Bank 0 - PS/2 Keyboard/Mouse Wake-Up Configuration and Control Register Map

Offset	Mnemonic	Register Name	Type	Section
13h	PS2CTL	PS/2 Protocol Control	R/W	3.4.18
14h-15h	Reserved			
16h	KDSR	Keyboard Data Shift	RO	3.4.19
17h	MDSR	Mouse Data Shift	RO	3.4.20
08h-1Fh	PS2KEY0-PS2KEY7	PS/2 Keyboard Key Data	R/W	3.4.21

Table 40. Bank 1 - CEIR Wake-Up Configuration and Control Register Map

Offset	Mnemonic	Register Name	Type	Section
13h	IRWCR	CEIR Wake-Up Control	R/W	3.4.22
14h	Reserved			
15h	IRWAD	CEIR Wake-Up Address	R/W	3.4.23
16h	IRWAM	CEIR Wake-Up Address Mask	R/W	3.4.24
17h	ADSR	CEIR Address Shift	R/O	3.4.25
18h	IRWTR0L	CEIR Wake-Up, Range 0, Low Limit	R/W	3.4.26
19h	IRWTR0H	CEIR Wake-Up, Range 0, High Limit	R/W	3.4.26
1Ah	IRWTR1L	CEIR Wake-Up, Range 1, Low Limit	R/W	3.4.27
1Bh	IRWTR1H	CEIR Wake-Up, Range 1, High Limit	R/W	3.4.27
1Ch	IRWTR2L	CEIR Wake-Up, Range 2, Low Limit	R/W	3.4.28
1Dh	IRWTR2H	CEIR Wake-Up, Range 2, High Limit	R/W	3.4.28
1Eh	IRWTR3L	CEIR Wake-Up, Range 3, Low Limit	R/W	3.4.29
1Fh	IRWTR3H	CEIR Wake-Up, Range 3, High Limit	R/W	3.4.29

Table 41. Bank 2 - Event Routing Configuration Register Map

Offset	Mnemonic	Register Name	Type	Section
13h	WK_SMIEN0	Wake-Up SMI Enable 0	R/W	3.4.7
14h	WK_SMIEN1	Wake-Up SMI Enable 1	R/W	3.4.8
15h	WK_IRQEN0	Wake-Up Interrupt Request Enable 0	R/W	3.4.9
16h	WK_IRQEN1	Wake-Up Interrupt Request Enable 1	R/W	3.4.10
17h	WK_X1EN0	Wake-Up Extension 1 Enable 0	R/W	3.4.11
18h	WK_X1EN1	Wake-Up Extension 1 Enable 1	R/W	3.4.12
19h	WK_X2EN0	Wake-Up Extension 2 Enable 0	R/W	3.4.13
1Ah	WK_X2EN1	Wake-Up Extension 2 Enable 1	R/W	3.4.14
1Bh	WK_X3EN0	Wake-Up Extension 3 Enable 0	R/W	3.4.15
1Ch	WK_X3EN1	Wake-Up Extension 3 Enable 1	R/W	3.4.16
1Dh-1Fh	Reserved			

3.0 System Wake-Up Control (SWC) (Continued)

Table 42. Bank 3 - Standby GPIO Pin Configuration Register Map

Offset	Mnemonic	Register Name	Type	Section
13h	SBGPSEL	Standby GPIO Pin Select	R/W	3.4.31
14h	SBGPCFG	Standby GPIO Pin Configuration	R/W	3.4.32
15h-1Fh	Reserved			

3.0 System Wake-Up Control (SWC) (Continued)

3.4.2 Wake-Up Events Status Register 0 (WK_STS0)

This register is set to 00h on power-up of V_{PP} , V_{SB} or software reset. It indicates which of the corresponding eight wake-up events have occurred. Writing 1 to a bit clears it to 0. Writing 0 has no effect. Bit 6 of this register has a special type, as described in the table below.

Location: Offset 00h

Type: R/W1C

Bit	7	6	5	4	3	2	1	0
Name	Module IRQ Event Status	Software Event Status	GPIO Event Status	CEIR Event Status	Mouse Event Status	KBD Event Status	$\overline{RI2}$ Event Status	$\overline{RI1}$ Event Status
Reset	0	0	0	0	0	0	0	0

Bit	Description
7	Module IRQ Event Status. This sticky bit shows the status of the module IRQ event detection. 0: Event not active (default) 1: Event active
6	Software Event Status. Writing 1 to this bit inverts its value. 0: Event not active (default) 1: Event active
5	GPIO Event Status. This sticky bit shows the status of the V_{DD} GPIO event detection. 0: Event not detected (default) 1: Event detected
4	CEIR Event Status 0: Event not detected (default) 1: Event detected
3	Mouse Event Status 0: Event not detected (default) 1: Event detected
2	KBD Event Status 0: Event not detected (default) 1: Event detected
1	$\overline{RI2}$ Event Status 0: Event not detected (default) 1: Event detected
0	$\overline{RI1}$ Event Status 0: Event not detected (default) 1: Event detected

3.0 System Wake-Up Control (SWC) (Continued)

3.4.3 Wake-Up Events Status Register (WK_STS1)

This register is set to 00h on power-up of V_{PP} , V_{SB} or software reset. It indicates which of the corresponding eight wake-up events have occurred. Writing 1 to a bit clears it to 0. Writing 0 has no effect.

Location: Offset 01h

Type: R/W1C

Bit	7	6	5	4	3	2	1	0
Name	GPIE7 Event Status	GPIE6 Event Status	GPIE5 Event Status	GPIE4/RING Event Status	GPIE3 Event Status	GPIE2 Event Status	GPIE1 Event Status	GPIE0 Event Status
Reset	0	0	0	0	0	0	0	0

Bit	Description
7	GPIE7 Event Status 0: Event not detected (default) 1: Event detected
6	GPIE6 Event Status 0: Event not detected (default) 1: Event detected
5	GPIE5 Event Status 0: Event not detected (default) 1: Event detected
4	GPIE4/RING Event Status. This sticky bit shows the status of either GPIE4 or RING event detection, according to the function currently selected on pin 27. 0: Event not detected (default) 1: Event detected
3	GPIE3 Event Status 0: Event not detected (default) 1: Event detected
2	GPIE2 Event Status 0: Event not detected (default) 1: Event detected
1	GPIE1 Event Status 0: Event not detected (default) 1: Event detected
0	GPIE0 Event Status 0: Event not detected (default) 1: Event detected

3.0 System Wake-Up Control (SWC) (Continued)

3.4.4 Wake-Up Events Enable Register (WK_EN0)

This register is set to 00h on power-up of V_{PP} or software reset. Detected wake-up events that are enabled activate the PWUREQ signal.

Location: Offset 02h

Type: R/W

Bit	7	6	5	4	3	2	1	0
Name	Module IRQ Event Enable	Software Event Enable	GPIO Event Enable	CEIR Event Enable	Mouse Event Enable	KBD Event Enable	$\overline{RI2}$ Event Enable	$\overline{RI1}$ Event Enable
Reset	0	0	0	0	0	0	0	0

Bit	Description
7	Module IRQ Event Enable 0: Disabled (default) 1: Enabled
6	Software Event Enable 0: Disabled (default) 1: Enabled
5	GPIO Event Enable 0: Disabled (default) 1: Enabled
4	CEIR Event Enable 0: Disabled (default) 1: Enabled
3	Mouse Event Enable 0: Disabled (default) 1: Enabled
2	KBD Event Enable 0: Disabled (default) 1: Enabled
1	$\overline{RI2}$ Event Enable 0: Disabled (default) 1: Enabled
0	$\overline{RI1}$ Event Enable 0: Disabled (default) 1: Enabled

3.0 System Wake-Up Control (SWC) (Continued)

3.4.5 Wake-Up Events Enable Register 1 (WK_EN1)

This register is set to 00h on power-up of V_{PP} or software reset. Detected wake-up events that are enabled activate the PWUREQ signal.

Location: Offset 03h

Type: R/W

Bit	7	6	5	4	3	2	1	0
Name	GPIE7 Event Enable	GPIE6 Event Enable	GPIE5 Event Enable	GPIE4/RING Event Enable	GPIE3 Event Enable	GPIE2 Event Enable	GPIE1 Event Enable	GPIE0 Event Enable
Reset	0	0	0	0	0	0	0	0

Bit	Description
7	GPIE7 Event Enable 0: Disabled (default) 1: Enabled
6	GPIE6 Event Enable 0: Disabled (default) 1: Enabled
5	GPIE5 Event Enable 0: Disabled (default) 1: Enabled
4	GPIE4/RING Event Enable 0: Disabled (default) 1: Enabled
3	GPIE3 Event Enable 0: Disabled (default) 1: Enabled.
2	GPIE2 Event Enable 0: Disabled (default) 1: Enabled
1	GPIE1 Event Enable 0: Disabled (default) 1: Enabled
0	GPIE0 Event Enable 0: Disabled (default) 1: Enabled

3.0 System Wake-Up Control (SWC) (Continued)

3.4.6 Wake-Up Configuration Register (WK_CFG)

This register is set to 00h on power-up of V_{PP} or software reset. It enables access to CEIR registers, keyboard/mouse registers, Event Routing Control registers or Standby GPIO registers.

Location: Offset 04h

Type: R/W

Bit	7	6	5	4	3	2	1	0
Name	Reserved				Enable Power Button Pulse on S3	Swap KBC Inputs	Configuration Bank Select	
Reset	0	0	0	0	0	0	0	0
Required	0	0						

Bit	Description																				
7-4	Reserved																				
3	Enable Power Button Pulse on S3 0: Disabled (default) 1: Enabled																				
2	Swap KBC Inputs 0: No swapping (default) 1: KBD (KBCLK, KBDAT) and Mouse (MCLK, MDAT) inputs swapped																				
1-0	Configuration Bank Select Bits <table border="1"> <thead> <tr> <th>1</th> <th>0</th> <th>Bank</th> <th>Register</th> </tr> </thead> <tbody> <tr> <td>0</td> <td>0</td> <td>0</td> <td>Keyboard/Mouse</td> </tr> <tr> <td>0</td> <td>1</td> <td>1</td> <td>CEIR</td> </tr> <tr> <td>1</td> <td>0</td> <td>2</td> <td>Event Routing, Wake-Up Extension</td> </tr> <tr> <td>1</td> <td>1</td> <td>3</td> <td>Standby GPIO</td> </tr> </tbody> </table>	1	0	Bank	Register	0	0	0	Keyboard/Mouse	0	1	1	CEIR	1	0	2	Event Routing, Wake-Up Extension	1	1	3	Standby GPIO
1	0	Bank	Register																		
0	0	0	Keyboard/Mouse																		
0	1	1	CEIR																		
1	0	2	Event Routing, Wake-Up Extension																		
1	1	3	Standby GPIO																		

3.0 System Wake-Up Control (SWC) (Continued)

3.4.7 Wake-Up Events Routing to $\overline{\text{SMI}}$ Enable Register 0 (WK_SMIEN0)

This register is set to 00h on power-up of V_{PP} or software reset. It controls the routing of detected wake-up events to the SMI signal. Detected wake-up events that are enabled activate the SMI signal regardless of the value of the WK_EN0 register.

Location: Bank 2, Offset 13h

Type: R/W

Bit	7	6	5	4	3	2	1	0
Name	Reserved	Software Event to $\overline{\text{SMI}}$ Enable	Reserved	CEIR Event to $\overline{\text{SMI}}$ Enable	Mouse Event to $\overline{\text{SMI}}$ Enable	KBD Event to $\overline{\text{SMI}}$ Enable	$\overline{\text{RI2}}$ Event to $\overline{\text{SMI}}$ Enable	$\overline{\text{RI1}}$ Event to $\overline{\text{SMI}}$ Enable
Reset	0	0	0	0	0	0	0	0

Bit	Description
7	Reserved
6	Software Event to $\overline{\text{SMI}}$ Enable 0: Disabled (default) 1: Enabled
5	Reserved
4	CEIR Event to $\overline{\text{SMI}}$ Enable 0: Disabled (default) 1: Enabled
3	Mouse Event to $\overline{\text{SMI}}$ Enable 0: Disabled (default) 1: Enabled
2	KBD Event to $\overline{\text{SMI}}$ Enable 0: Disabled (default) 1: Enabled
1	$\overline{\text{RI2}}$ Event to $\overline{\text{SMI}}$ Enable 0: Disabled (default) 1: Enabled
0	$\overline{\text{RI1}}$ Event to $\overline{\text{SMI}}$ Enable 0: Disabled (default) 1: Enabled

3.0 System Wake-Up Control (SWC) (Continued)

3.4.8 Wake-Up Events Routing to $\overline{\text{SMI}}$ Enable Register 1 (WK_SMIEN1)

This register is set to 00h on power-up of V_{PP} or software reset. It controls the routing of detected wake-up events to the SMI signal. Detected wake-up events that are enabled activate the SMI signal regardless of the value of the WK_EN1 register.

Location: Bank 2, Offset 14h

Type: R/W

Bit	7	6	5	4	3	2	1	0
Name	GPIE7 Event to $\overline{\text{SMI}}$ Enable	GPIE6 Event to $\overline{\text{SMI}}$ Enable	GPIE5 Event to $\overline{\text{SMI}}$ Enable	GPIE4/ RING Event to $\overline{\text{SMI}}$ Enable	GPIE3 Event to $\overline{\text{SMI}}$ Enable	GPIE2 Event to $\overline{\text{SMI}}$ Enable	GPIE1 Event to $\overline{\text{SMI}}$ Enable	GPIE0 Event to $\overline{\text{SMI}}$ Enable
Reset	0	0	0	0	0	0	0	0

Bit	Description
7	GPIE7 Event to $\overline{\text{SMI}}$ Enable 0: Disabled (default) 1: Enabled
6	GPIE6 Event to $\overline{\text{SMI}}$ Enable 0: Disabled (default) 1: Enabled
5	GPIE5 Event to $\overline{\text{SMI}}$ Enable 0: Disabled (default) 1: Enabled
4	GPIE4/RING Event to $\overline{\text{SMI}}$ Enable 0: Disabled (default) 1: Enabled
3	GPIE3 Event to $\overline{\text{SMI}}$ Enable 0: Disabled (default) 1: Enabled.
2	GPIE2 Event to $\overline{\text{SMI}}$ Enable 0: Disabled (default) 1: Enabled
1	GPIE1 Event to $\overline{\text{SMI}}$ Enable 0: Disabled (default) 1: Enabled
0	GPIE0 Event to $\overline{\text{SMI}}$ Enable 0: Disabled (default) 1: Enabled

3.0 System Wake-Up Control (SWC) (Continued)

3.4.9 Wake-Up Events Routing to IRQ Enable Register 0 (WK_IRQEN0)

This register is set to 00h on power-up of V_{PP} or software reset. It controls the routing of detected wake-up events to the assigned SWC interrupt request (IRQ) channel. Detected wake-up events that are enabled activate the assigned IRQ channel regardless of the value of the WK_EN0 register.

Location: Bank 2, Offset 15h

Type: R/W

Bit	7	6	5	4	3	2	1	0
Name	Reserved	Software Event to IRQ Enable	Reserved	CEIR Event to IRQ Enable	Mouse Event to IRQ Enable	KBD Event to IRQ Enable	$\overline{RI2}$ Event to IRQ Enable	$\overline{RI1}$ Event to IRQ Enable
Reset	0	0	0	0	0	0	0	0

Bit	Description
7	Reserved
6	Software Event to IRQ Enable 0: Disabled (default) 1: Enabled
5	Reserved
4	CEIR Event to IRQ Enable 0: Disabled (default) 1: Enabled
3	Mouse Event to IRQ Enable 0: Disabled (default) 1: Enabled
2	KBD Event to IRQ Enable 0: Disabled (default) 1: Enabled.
1	$\overline{RI2}$ Event to IRQ Enable 0: Disabled (default) 1: Enabled
0	$\overline{RI1}$ Event to IRQ Enable 0: Disabled (default) 1: Enabled

3.0 System Wake-Up Control (SWC) (Continued)

3.4.10 Wake-Up Events Routing to IRQ Enable Register 1 (WK_IRQEN1)

This register is set to 00h on power-up of V_{PP} or software reset. It controls the routing of detected wake-up events to the assigned SWC IRQ channel. Detected wake-up events that are enabled activate the IRQ signal regardless of the value of the WK_EN1 register.

Location: Bank 2, Offset 16h

Type: R/W

Bit	7	6	5	4	3	2	1	0
Name	GPIE7 Event to IRQ Enable	GPIE6 Event to IRQ Enable	GPIE5 Event to IRQ Enable	GPIE4/ RING Event to IRQ Enable	GPIE3 Event to IRQ Enable	GPIE2 Event to IRQ Enable	GPIE1 Event to IRQ Enable	GPIE0 Event to IRQ Enable
Reset	0	0	0	0	0	0	0	0

Bit	Description
7	GPIE7 Event to IRQ Enable 0: Disabled (default) 1: Enabled
6	GPIE6 Event to IRQ Enable 0: Disabled (default) 1: Enabled
5	GPIE5 Event to IRQ Enable 0: Disabled (default) 1: Enabled
4	GPIE4/RING Event to IRQ Enable 0: Disabled (default) 1: Enabled
3	GPIE3 Event to IRQ Enable 0: Disabled (default) 1: Enabled.
2	GPIE2 Event to IRQ Enable 0: Disabled (default) 1: Enabled
1	GPIE1 Event to IRQ Enable 0: Disabled (default) 1: Enabled
0	GPIE0 Event to IRQ Enable 0: Disabled (default) 1: Enabled

3.0 System Wake-Up Control (SWC) (Continued)

3.4.11 Wake-Up Extension 1 Enable Register 0 (WK_X1EN0)

This register is set to 1Fh on power-up of V_{PP} or software reset. It controls the routing of raw wake-up events to event detectors while V_{DD} is present. Wake-up events that are enabled are routed to their event detectors while V_{DD} is present.

Location: Bank 2, Offset 17h

Type: R/W

Bit	7	6	5	4	3	2	1	0
Name	Reserved			CEIR Event Ex. 1 Enable	Mouse Event Ex. 1 Enable	KBD Event Ex. 1 Enable	$\overline{\text{RI2}}$ Event Ex. 1 Enable	$\overline{\text{RI1}}$ Event Ex.1 Enable
Reset	0	0	0	1	1	1	1	1

Bit	Description
7-5	Reserved
4	CEIR Event Extension 1 Enable 0: Disabled 1: Enabled (default)
3	Mouse Event Extension 1 Enable 0: Disabled 1: Enabled (default)
2	KBD Event Extension 1 Enable 0: Disabled 1: Enabled (default)
1	$\overline{\text{RI2}}$ Event Extension 1 Enable 0: Disabled 1: Enabled (default)
0	$\overline{\text{RI1}}$ Event Extension 1 Enable 0: Disabled 1: Enabled (default)

3.0 System Wake-Up Control (SWC) (Continued)

3.4.12 Wake-Up Extension 1 Enable Register 1 (WK_X1EN1)

This register is set to FFh on power-up of V_{PP} or software reset. It controls the routing of raw wake-up events to event detectors while V_{DD} is present. Wake-up events that are enabled are routed to their event detectors while V_{DD} is present.

Location: Bank 2, Offset 18h

Type: R/W

Bit	7	6	5	4	3	2	1	0
Name	GPIE7 Event Ex. 1 Enable	GPIE6 Event Ex. 1 Enable	GPIE5 Event Ex. 1 Enable	GPIE4/ RING Event Ex. 1 Enable	GPIE3 Event Ex. 1 Enable	GPIE2 Event Ex. 1 Enable	GPIE1 Event Ex. 1 Enable	GPIE0 Event Ex. 1 Enable
Reset	1	1	1	1	1	1	1	1

Bit	Description
7	GPIE7 Event Extension 1 Enable 0: Disabled 1: Enabled (default)
6	GPIE6 Event Extension 1 Enable 0: Disabled 1: Enabled (default)
5	GPIE5 Event Extension 1 Enable 0: Disabled 1: Enabled (default)
4	GPIE4/RING Event Extension 1 Enable 0: Disabled 1: Enabled (default)
3	GPIE3 Event Extension 1 Enable 0: Disabled 1: Enabled (default)
2	GPIE2 Event Extension 1 Enable 0: Disabled 1: Enabled (default)
1	GPIE1 Event Extension 1 Enable 0: Disabled 1: Enabled (default)
0	GPIE0 Event Extension 1 Enable 0: Disabled 1: Enabled (default)

3.0 System Wake-Up Control (SWC) (Continued)

3.4.13 Wake-Up Extension 2 Enable Register 0 (WK_X2EN0)

This register is set to 1Fh on power-up of V_{PP} or software reset. It controls the routing of raw wake-up events to event detectors while V_{DD} is not present. Wake-up events that are enabled are routed to their event detectors while V_{DD} is not present.

Location: Bank 2, Offset 19h

Type: R/W

Bit	7	6	5	4	3	2	1	0
Name	Reserved			CEIR Event Ex. 2 Enable	Mouse Event Ex. 2 Enable	KBD Event Ex. 2 Enable	$\overline{RI2}$ Event Ex. 2 Enable	$\overline{RI1}$ Event Ex. 2 Enable
Reset	0	0	0	1	1	1	1	1

Bit	Description
7-5	Reserved
4	CEIR Event Extension 2 Enable 0: Disabled 1: Enabled (default)
3	Mouse Event Extension 2 Enable 0: Disabled 1: Enabled (default)
2	KBD Event Extension 2 Enable 0: Disabled 1: Enabled (default)
1	$\overline{RI2}$ Event Extension 2 Enable 0: Disabled 1: Enabled (default)
0	$\overline{RI1}$ Event Extension 2 Enable 0: Disabled 1: Enabled (default)

3.0 System Wake-Up Control (SWC) (Continued)

3.4.14 Wake-Up Extension 2 Enable Register 1 (WK_X2EN1)

This register is set to FFh on power-up of V_{PP} or software reset. It controls the routing of raw wake-up events to event detectors while V_{DD} is not present. Wake-up events that are enabled are routed to their event detectors while V_{DD} is not present.

Location: Bank 2, Offset 1Ah

Type: R/W

Bit	7	6	5	4	3	2	1	0
Name	GPIE7 Event Ex. 2 Enable	GPIE6 Event Ex. 2 Enable	GPIE5 Event Ex. 2 Enable	GPIE4/ RING Event Ex. 2 Enable	GPIE3 Event Ex. 2 Enable	GPIE2 Event Ex. 2 Enable	GPIE1 Event Ex. 2 Enable	GPIE0 Event Ex. 2 Enable
Reset	1	1	1	1	1	1	1	1

Bit	Description
7	GPIE7 Event Extension 2 Enable 0: Disabled 1: Enabled (default)
6	GPIE6 Event Extension 2 Enable 0: Disabled 1: Enabled (default)
5	GPIE5 Event Extension 2 Enable 0: Disabled 1: Enabled (default)
4	GPIE4/RING Event Extension 2 Enable 0: Disabled 1: Enabled (default)
3	GPIE3 Event Extension 2 Enable 0: Disabled 1: Enabled (default)
2	GPIE2 Event Extension 2 Enable 0: Disabled 1: Enabled (default)
1	GPIE1 Event Extension 2 Enable 0: Disabled 1: Enabled (default)
0	GPIE0 Event Extension 2 Enable 0: Disabled 1: Enabled (default)

3.0 System Wake-Up Control (SWC) (Continued)

3.4.15 Wake-Up Extension 3 Enable Register 0 (WK_X3EN0)

This register is set to 00h on power-up of V_{PP} or software reset. It controls the routing of raw wake-up events to the Power Button pulse generator. Wake-up events that are enabled are routed to the Power Button pulse generator.

Location: Bank 2, Offset 1Bh

Type: R/W

Bit	7	6	5	4	3	2	1	0
Name	Reserved			CEIR Event Ex. 3 Enable	Mouse Event Ex. 3 Enable	KBD Event Ex. 3 Enable	$\overline{RI2}$ Event Ex. 3 Enable	$\overline{RI1}$ Event Ex. 3 Enable
Reset	0	0	0	0	0	0	0	0

Bit	Description
7-5	Reserved
4	CEIR Event Extension 3 Enable 0: Disabled (default) 1: Enabled
3	Mouse Event Extension 3 Enable 0: Disabled (default) 1: Enabled
2	KBD Event Extension 3 Enable 0: Disabled (default) 1: Enabled
1	$\overline{RI2}$ Event Extension 3 Enable 0: Disabled (default) 1: Enabled
0	$\overline{RI1}$ Event Extension 3 Enable 0: Disabled (default) 1: Enabled

3.0 System Wake-Up Control (SWC) (Continued)

3.4.16 Wake-Up Extension 3 Enable Register 1 (WK_X3EN1)

This register is set to 00h on power-up of V_{PP} or software reset. It controls the routing of raw wake-up events to the Power Button pulse generator. Wake-up events that are enabled are routed to the Power Button pulse generator.

Location: Bank 2, Offset 1Ch

Type: R/W

Bit	7	6	5	4	3	2	1	0
Name	GPIE7 Event Ex. 3 Enable	GPIE6 Event Ex. 3 Enable	GPIE5 Event Ex. 3 Enable	GPIE3/ RING Event Ex. 3 Enable	GPIE3 Event Ex. 3 Enable	GPIE2 Event Ex. 3 Enable	GPIE1 Event Ex. 3 Enable	GPIE0 Event Ex. 3 Enable
Reset	0	0	0	0	0	0	0	0

Bit	Description
7	GPIE7 Event Extension 3 Enable 0: Disabled (default) 1: Enabled
6	GPIE6 Event Extension 3 Enable 0: Disabled (default) 1: Enabled
5	GPIE5 Event Extension 3 Enable 0: Disabled (default) 1: Enabled
4	GPIE4/RING Event Extension 3 Enable 0: Disabled (default) 1: Enabled
3	GPIE3 Event Extension 3 Enable 0: Disabled (default) 1: Enabled
2	GPIE2 Event Extension 3 Enable 0: Disabled (default) 1: Enabled
1	GPIE1 Event Extension 3 Enable 0: Disabled (default) 1: Enabled
0	GPIE0 Event Extension 3 Enable 0: Disabled (default) 1: Enabled

3.0 System Wake-Up Control (SWC) (Continued)

3.4.17 PS/2 Keyboard and Mouse Wake-Up Events

The SWC can be configured to detect any predetermined PS/2 keyboard or mouse activity.

The detection mechanisms for keyboard and mouse events are independent. Therefore, they can be operated simultaneously with no interference. Since both mechanisms are implemented by hardware which is independent of the device's keyboard controller, the keyboard controller itself need not be activated to detect either keyboard or mouse events.

Keyboard Wake-Up Events

The keyboard wake-up detection mechanism can be programmed to detect:

- Any keystroke
- A specific programmable sequence of up to eight alphanumeric keystrokes (Password mode)
- Any programmable sequence of up to 8 bytes of data received from the keyboard (Special Key Sequence mode).

To program the keyboard wake-up detection mechanism to wake-up on any keystroke, perform the following sequence:

1. Put the wake-up mechanism in Special Key Sequence mode by setting bits 3-0 of the PS2CTL register to 0001b.
2. Set the PS2KEY0 and PS2KEY1 registers to 00h. This forces the wake-up detection mechanism to ignore the values of incoming data, thus causing it to wake-up on any keystroke.

In Password mode, the Make and Break bytes transmitted by the keyboard are discarded, and only the scan codes are compared against those programmed in the PS2KEYn registers. To simplify the detection mechanism, only keys with a scan code of 1 byte can be included in the sequence to be detected. To program the keyboard wake-up detection mechanism to operate in Password mode, proceed as follows:

1. Set bits 3-0 of the PS2CTL register with a value that indicates the desired number of keystrokes in the sequence. The programmed value should be the number of keystrokes + 7. For example, to wake-up on a sequence of two keys, set bits 3-0 to 9h.
2. Program the appropriate subset of the PS2KEY0-PS2KEY7 registers, in sequential order, with the scan codes of the keys in the sequence. For example, if there are three keys in the sequence and the scan codes of these keys are 05h (first), 50h (second) and 44h (third), program PS2KEY0 to 05h, PS2KEY1 to 50h and PS2KEY2 to 44h (the scan codes are only examples).

In Special Key Sequence mode, all the bytes transmitted by the keyboard are compared against the ones programmed in the PS2KEYn registers. These include also the Make and Break bytes. This mode enables the detection of any sequence of keystrokes, including also keys such as Shift and Alt. To program the keyboard wake-up detection mechanism to operate in Special Key Sequence mode, proceed as follows:

1. Set bits 3-0 of the PS2CTL register to a value that indicates the desired number of keystrokes in the sequence. The programmed value should be the number of keystrokes + 1. For example, to wake-up on a sequence of three received bytes, set bits 3-0 of PS2CTL to 2h.
2. Program the appropriate subset of the PS2KEY0-PS2KEY7 registers, in sequential order, with the values of the data bytes that comprise the sequence. For example, if the number of bytes in the sequence is four, and the values of these bytes are E0h (first), 5Bh (second), E0h (third) and DBh (fourth), program PS2KEY0 to E0h, PS2KEY1 to 5Bh, PS2KEY2 to E0h and PS2KEY3 to DBh (the byte values are only examples).

Mouse Wake-Up Events

The mouse wake-up detection mechanism can be programmed to detect either any mouse click or movement, or a specific programmable click (left or right) or double-click.

To program this mechanism to wake-up on a specific event, set bits 6-4 of the PS2CTL register to the required value, according to the description of these bits in Section 3.4.18.

3.0 System Wake-Up Control (SWC) (Continued)

3.4.18 PS/2 Protocol Control Register (PS2CTL)

This register is set to 00h on power-up of V_{PP} or software reset. It configures the PS/2 keyboard and mouse wake-up features. Before changing bits 6-4 or 3-0, clear them to 0 and then write the new value.

Location: Bank 0, Offset 13h

Type: R/W

Bit	7	6	5	4	3	2	1	0
Name	Disable Parity Check	Mouse Wake-Up Configuration			Keyboard Wake-Up Configuration			
Reset	0	0	0	0	0	0	0	0

Bit	Description
7	Disable Parity Check 0: Enabled (default) 1: Disabled
6-4	Mouse Wake-Up Configuration Bits 6 5 4 Configuration 0 0 0 Disable mouse wake-up detection 0 0 1 Wake-up on any mouse movement or button click 0 1 0 Wake-up on left button click 0 1 1 Wake-up on left button double-click 1 0 0 Wake-up on right button click 1 0 1 Wake-up on right button double-click 1 1 0 Wake-up on any button single-click (left, right or middle) 1 1 1 Wake-up on any button double-click (left, right or middle)
3-0	Keyboard Wake-Up Configuration Bits 3 2 1 0 Configuration 0 0 0 0 Disable keyboard wake-up detection 0 0 0 1 to 0 1 1 1 } Special key sequence 2-8 PS/2 scan codes, "Make" and "Break" (including Shift and Alt keys) 1 0 0 0 to 1 1 1 1 } Password enabled with 1-8 keys "Make" code (excluding Shift and Alt keys)

3.4.19 Keyboard Data Shift Register (KDSR)

This register is set to 00h on power-up of V_{PP} or software reset. It stores the keyboard data shifted in from the keyboard during transmission, only when keyboard wake-up detection is enabled.

Location: Bank 0, Offset 16h

Type: RO

Bit	7	6	5	4	3	2	1	0
Name	Keyboard Data							
Reset	0	0	0	0	0	0	0	0

3.0 System Wake-Up Control (SWC) (Continued)

3.4.20 Mouse Data Shift Register (MDSR)

This register is set to 00h on power-up of V_{SB} or software reset. It stores the mouse data shifted in from the mouse during transmission, only when mouse wake-up detection is enabled.

Location: Bank 0, Offset 17h

Type: RO

Bit	7	6	5	4	3	2	1	0
Name	Reserved					Mouse Data		
Reset	0	0	0	0	0	0	0	0

3.4.21 PS/2 Keyboard Key Data Registers (PS2KEY0 - PS2KEY7)

Eight registers (PS2KEY0-PS2KEY7) store the scan codes for the password or key sequence of the keyboard wake-up feature, as follows:

- PS2KEY0 register stores the scan code for the first key in the password/key sequence.
- PS2KEY1 register stores the scan code for the second key in the password/key sequence.
- PS2KEY2 - PS2KEY7 registers store the scan codes for the third to eighth keys in the password/key sequence.

When one of these registers is set to 00h, it indicates that the value of the corresponding scan code byte is ignored (not compared). These registers are set to 00h on power-up of V_{PP} or software reset.

Location: Bank 0, Offset 18h-1Fh

Type: R/W

Bit	7	6	5	4	3	2	1	0
Name	Scan Code of Keys 0-7							
Reset	0	0	0	0	0	0	0	0

3.0 System Wake-Up Control (SWC) (Continued)

3.4.22 CEIR Wake-Up Control Register (IRWCR)

This register is set to 00h on power-up of V_{PP} or software reset.

Location: Bank 1, Offset 13h

Type: R/W

Bit	7	6	5	4	3	2	1	0
Name	Reserved		CEIR Protocol Select		Select IRRX2 Input	Invert IRRXn Input	Reserved	CEIR Enable
Reset	0	0	0	0	0	0	0	0

Bit	Description												
7-6	Reserved												
5-4	CEIR Protocol Select Bits <table border="0"> <tr> <td>5</td> <td>4</td> <td>Protocol</td> </tr> <tr> <td>0</td> <td>0</td> <td>RC5 (default)</td> </tr> <tr> <td>0</td> <td>1</td> <td>NEC/RCA</td> </tr> <tr> <td>1</td> <td>X</td> <td>Reserved</td> </tr> </table>	5	4	Protocol	0	0	RC5 (default)	0	1	NEC/RCA	1	X	Reserved
5	4	Protocol											
0	0	RC5 (default)											
0	1	NEC/RCA											
1	X	Reserved											
3	Select IRRX2 Input. Selects the IRRX input. 0: IRRX1 (default) 1: IRRX2												
2	Invert IRRXn Input 0: Not inverted (default) 1: Inverted												
1	Reserved.												
0	CEIR Enable 0: CEIR is disabled. Registers are maintained, but CEIR Event Status bit (of WK0_STS) does not reflect CEIR events. (Unlike the CEIR Event Enable bit of WK0_EN that does not affect the CEIR Event Status bit.) (default) 1: CEIR is enabled												

3.0 System Wake-Up Control (SWC) (Continued)

3.4.23 CEIR Wake-Up Address Register (IRWAD)

This register holds the unique address to be compared with the address contained in the incoming CEIR message. If CEIR is enabled (bit 0 of the IRWCR register is 1) and an address match occurs, then bit 5 of the WK0_STS register is set to 1 (see Section 3.4.2).

This register is set to 00h on power-up of V_{PP} or software reset.

Location: Bank 1, Offset 15h

Type: R/W

Bit	7	6	5	4	3	2	1	0
Name	CEIR Wake-Up Address							
Reset	0	0	0	0	0	0	0	0

3.4.24 CEIR Wake-Up Address Mask Register (IRWAM)

Each bit in this register determines whether the corresponding bit in the IRWAD register is enabled in the address comparison. Bits 5, 6 and 7 must be set to 1 if the RC-5 protocol is selected.

This register is set to E0h on power-up of V_{PP} or software reset.

Location: Bank 1, Offset 16h

Type: R/W

Bit	7	6	5	4	3	2	1	0
Name	CEIR Wake-Up Address Mask							
Reset	1	1	1	0	0	0	0	0

Bit	Description
7-0	CEIR Wake-Up Address Mask. If the corresponding bit is 0, the address bit is not masked (enabled for compare). If the corresponding bit is 1, the address bit is masked (ignored during compare).

3.0 System Wake-Up Control (SWC) (Continued)

3.4.25 CEIR Address Shift Register (ADSR)

This register holds the received address to be compared with the address contained in the IRWAD register.

This register is set to 00h on power-up of V_{PP} or software reset.

Location: Bank 1, Offset 17h

Type: RO

Bit	7	6	5	4	3	2	1	0
Name	CEIR Address							
Reset	0	0	0	0	0	0	0	0

3.4.26 CEIR Wake-Up Range 0 Registers

These registers define the low and high limits of time range 0. The values are represented in units of 0.1 msec.

For the RC-5 protocol, the bit cell width must fall within this range for the cell to be considered valid. The nominal cell width is 1.778 msec for a 36 KHz carrier. IRWTR0L and IRWTR0H should be set to 10h and 14h respectively (default).

For the NEC protocol, the time distance between two consecutive CEIR pulses that encodes a bit value of 0 must fall within this range. The nominal distance for a 0 is 1.125 msec for a 38 KHz carrier. IRWTR0L and IRWTR0H should be set to 09h and 0Dh respectively.

IRWTR0L Register

This register is set to 10h on power-up of V_{PP} or software reset.

Location: Bank 1, Offset 18h

Type: R/W

Bit	7	6	5	4	3	2	1	0
Name	Reserved			CEIR Pulse Change, Range 0, Low Limit				
Reset	0	0	0	1	0	0	0	0

IRWTR0H Register

This register is set to 14h on power-up of V_{PP} or software reset.

Location: Bank 1, Offset 19h

Type: R/W

Bit	7	6	5	4	3	2	1	0
Name	Reserved			CEIR Pulse Change, Range 0, High Limit				
Reset	0	0	0	1	0	1	0	0

3.0 System Wake-Up Control (SWC) (Continued)

3.4.27 CEIR Wake-Up Range 1 Registers

These registers define the low and high limits of time range 1. The values are represented in units of 0.1 msec.

For the RC-5 protocol, the pulse width defining a half-bit cell must fall within this range in order for the cell to be considered valid. The nominal pulse width is 0.889 for a 38 KHz carrier. IRWTR1L and IRWTR1H should be set to 07h and 0Bh respectively (default).

For the NEC protocol, the time between two consecutive CEIR pulses that encodes a bit value of 1 must fall within this range. The nominal time for a 1 is 2.25 msec for a 36 KHz carrier. IRWTR1L and IRWTR1H should be set to 14h and 19h respectively.

IRWTR1L Register

This register is set to 07h on power-up of V_{PP} or software reset.

Location: Bank 1, Offset 1Ah

Type: R/W

Bit	7	6	5	4	3	2	1	0
Name	Reserved			CEIR Pulse Change, Range 1, Low Limit				
Reset	0	0	0	0	0	1	1	1

IRWTR1H Register

This register is set to 0Bh on power-up of V_{PP} or software reset.

Location: Bank 1, Offset 1Bh

Type: R/W

Bit	7	6	5	4	3	2	1	0
Name	Reserved			CEIR Pulse Change, Range 1, High Limit				
Reset	0	0	0	0	1	0	1	1

3.4.28 CEIR Wake-Up Range 2 Registers

These registers define the low and high limits of time range 2. The values are represented in units of 0.1 msec. These registers are not used when the RC-5 protocol is selected.

For the NEC protocol, the header pulse width must fall within this range in order for the header to be considered valid. The nominal value is 9 msec for a 38 KHz carrier. IRWTR2L and IRWTR2H should be set to 50h and 64h respectively (default).

IRWTR2L Register

This register is set to 50h on power-up of V_{PP} or software reset.

Location: Bank 1, Offset 1Ch

Type: R/W

Bit	7	6	5	4	3	2	1	0
Name	CEIR Pulse Change, Range 2, Low Limit							
Reset	0	1	0	1	0	0	0	0

IRWTR2H Register

This register is set to 64h on power-up of V_{PP} or software reset.

Location: Bank 1, Offset 1Dh

Type: R/W

Bit	7	6	5	4	3	2	1	0
Name	CEIR Pulse Change, Range 2, High Limit							
Reset	0	1	1	0	0	1	0	0

3.0 System Wake-Up Control (SWC) (Continued)

3.4.29 CEIR Wake-Up Range 3 Registers

These registers define the low and high limits of time range 3. The values are represented in units of 0.1 msec. These registers are not used when the RC-5 protocol is selected.

For the NEC protocol, the post header gap width must fall within this range in order for the gap to be considered valid. The nominal value is 4.5 msec for a 36 KHz carrier. IRWTR3L and IRWTR3H should be set to 28h and 32h respectively (default).

IRWTR3L Register

This register is set to 28h on power-up of V_{pp} or software reset.

Location: Bank1, Offset 1Eh

Type: R/WS

Bit	7	6	5	4	3	2	1	0
Name	CEIR Pulse Change, Range 3, Low Limit							
Reset	0	0	1	0	1	0	0	0

IRWTR3H Register

This register is set to 32h on power-up of V_{pp} or software reset.

Location: Bank 1, Offset 1Fh

Type: R/W

Bit	7	6	5	4	3	2	1	0
Name	CEIR Pulse Change, Range 3, High Limit							
Reset	0	0	1	1	0	0	1	0

CEIR Recommended Values

Table 43 lists the recommended time ranges limits for the different protocols and their four applicable ranges. The values are represented in hexadecimal code where the units are of 0.1 msec.

Table 43. Time Range Limits for CEIR Protocols

Range	RC-5		NEC		RCA	
	Low Limit	High Limit	Low Limit	High Limit	Low Limit	High Limit
0	10h	14h	09h	0Dh	0Ch	12h
1	07h	0Bh	14h	19h	16h	1Ch
2	–	–	50h	64h	B4h	DCh
3	–	–	28h	32h	23h	2Dh

3.0 System Wake-Up Control (SWC) (Continued)

3.4.30 Standby General-Purpose I/O (SBGPIO) Register Overview

The SWC can be used to operate up to 12 V_{SB} -powered general-purpose input/output (GPIO), input (GPI) or output (GPO) pins, eight of which support event detection. These are as follows:

- GPIOE0-5 are GPIO pins.
- GPIE6,7 and GPIS2,3 are GPI pins.
- GPOS0,1 are GPO pins.

For programming convenience, these pins are associated with two SBGPIO ports. Specifically, GPIE0-5 and GPIE6,7 are associated with bits 0 to 7 of SBGPIO port 0, respectively, and GPOS0,1 and GPIS2,3 are associated with bits 0 to 3 of SBGPIO port 1, respectively.

Table 44 provides a summary of the SBGPIO pin-to-port assignment and pin types.

Table 44. SBGPIO Pin Types and Associated Port

Pin(s)	Port	Type	Event Detection
GPIOE0-5	0	I/O	Yes
GPIE6,7	0	I	Yes
GPOS0,1	1	O	No
GPIS2,3	1	I	No

An SBGPIO port is structured as an 8-bit port, based on eight pins. It features:

- Software capability to manipulate and read pin levels
- Controllable system notification by several means based on the pin level or level transition
- Ability to capture and manipulate events and their associated status
- Back-drive protected pins.

SBGPIO port operation is associated with two sets of registers:

- Pin configuration registers, mapped in the SWC register bank 3. These registers are used to statically set up the logical behavior of each pin. There is one 8-bit register for each SBGPIO pin.
- Two 8-bit runtime registers: SBGPIO Data Out (SBGPDO) and SBGPIO Data In (SBGPDI). These registers are mapped in the SWC device I/O space (determined by the base address registers in the SWC Device Configuration). They are used to manipulate and/or read the pin values. Each runtime register corresponds to the 8-pin port described above (see Table 44).

Each SBGPIO pin is associated with up to six configuration bits and the corresponding bit slice of the two runtime registers, as shown in Figure 10.

The SBGPIO port has basic as well as enhanced functionality. Basic functionality includes the manipulation and reading of the SBGPIO pins, as described in Section . Enhanced functionality includes event detection, as described in *Event Detection*.

3.0 System Wake-Up Control (SWC) (Continued)

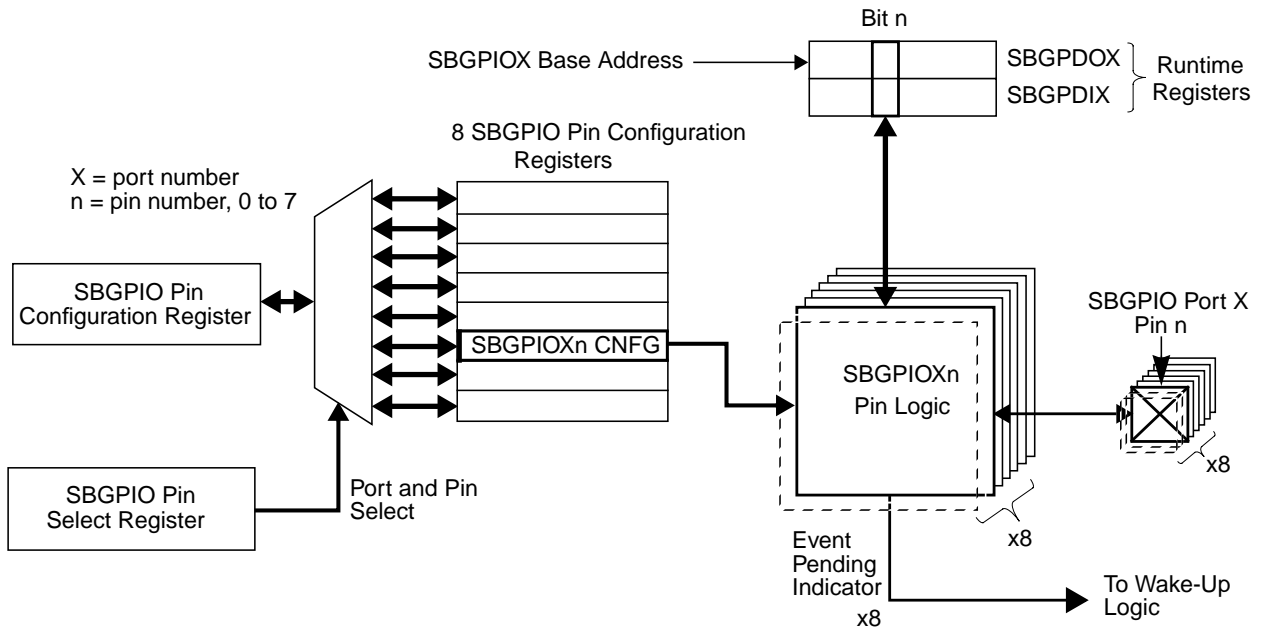

Figure 10. SBGPIO Port Architecture

Basic Functionality

The basic functionality of each SBGPIO pin is based on four configuration bits and a bit slice of runtime registers SBGPDO and SBGPD. The configuration and operation of a single pin (pin n in port X) is shown in Figure 11.

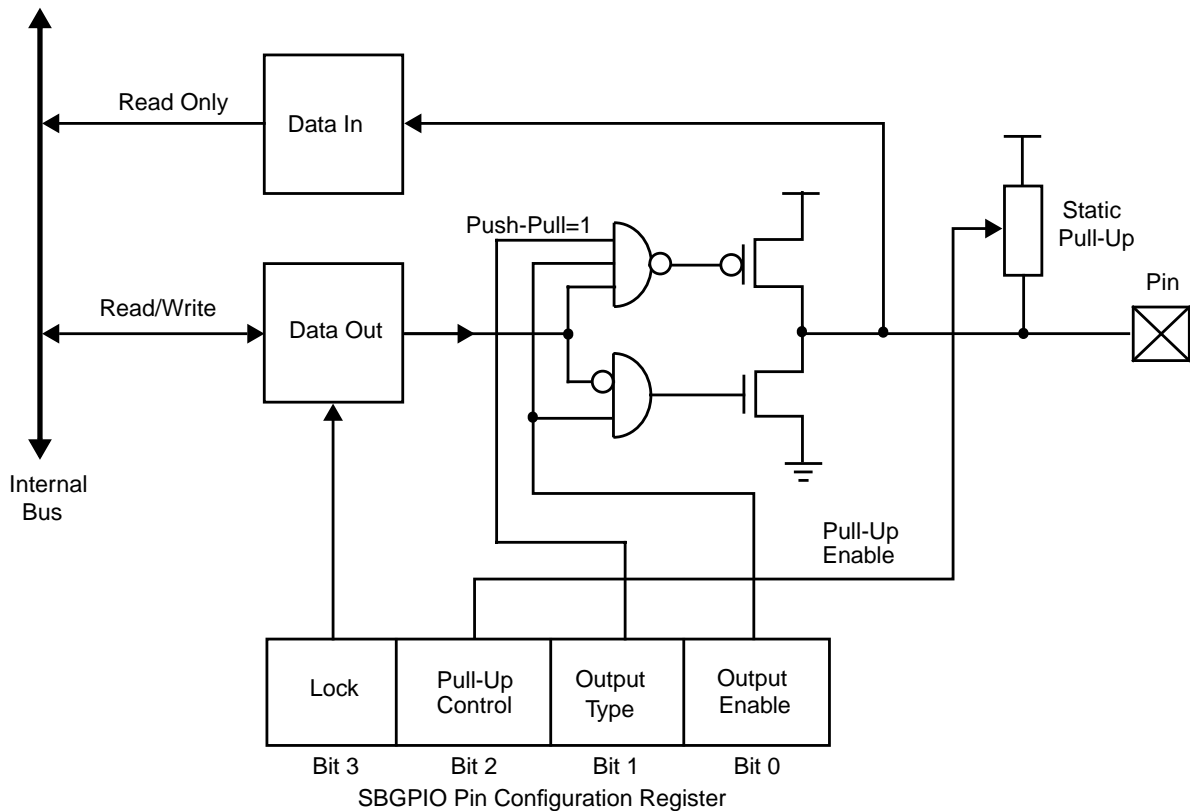

Figure 11. SBGPIO Basic Functionality

3.0 System Wake-Up Control (SWC) (Continued)

Configuration Options

The SBGPIO Pin Configuration register controls the following basic configuration options:

- Pin Direction - Controlled by Output Enable (bit 0)
- Output Type - Push-pull vs. open-drain. It is controlled by Output Type (bit 1) by enabling/disabling the pull-up portion of the output buffer.
- Weak Static Pull-up - May be added to any type of port (input, open-drain or totem pole). It is controlled by Pull-Up Control (bit 2).
- Pin Lock - A GPIO pin may be locked to prevent any changes in the output value and/or the output characteristics. The lock is controlled by Lock (bit 3). It disables writes to the SBGPDO register bits, and to bits 0-3 of the Standby GPIO Pin Configuration register (Including the Lock bit itself). Once locked, it can be released by hardware reset only.

Operation

The value that is written to the SBGPDO register is driven to the pin, if the output is enabled. Reading from the SBGPDO register returns its contents, regardless of the pin value or the port configuration. The SBGPD1 register is a read-only register. Reading from the SBGPD1 register returns the pin value, regardless of what is driving it (the port itself, configured as an output port, or the external device when the port is configured as an input port). Writing to this register is ignored.

Activation of the SBGPIO port is controlled by the same external, device-specific configuration bit (or a combination of bits) that control the activation of the SWC. When the SWC logical device is inactive, access to both the SBGPD1 and SBGPDO registers is disabled. However, there is no change in the port configuration and in the SBGPDO value, and hence there is no effect on the outputs of the pins.

Event Detection

The enhanced SBGPIO port supports input event detection. This functionality is based on three configuration bits. The configuration and operation of the event detection capability is shown in Figure 12. An SWC status register reflects the status of each input event. SWC configuration registers determine the effect of each input event on the various means of system notification available in the SWC.

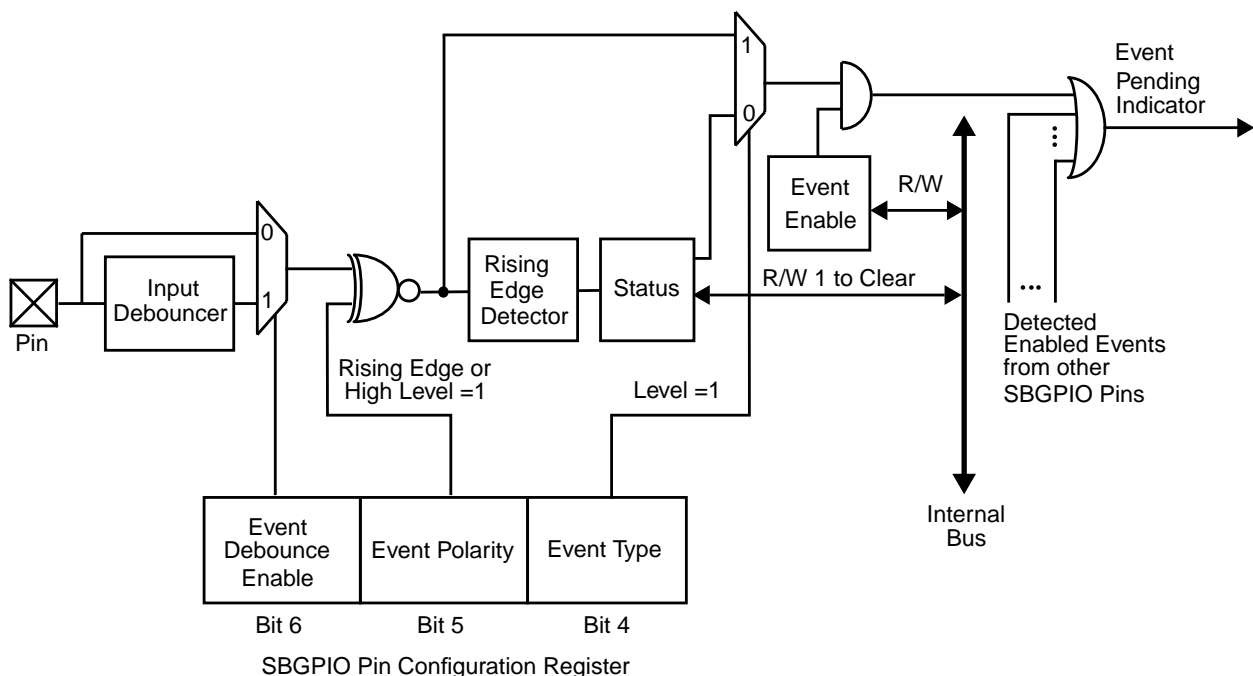

Figure 12. Event Detection

3.0 System Wake-Up Control (SWC) (Continued)

Event Configuration

Each pin in the SBGPIO port is a potential input event source. The event detection can trigger a system notification upon predetermined behavior of the source pin. The SBGPIO Pin Configuration register determines the event detection trigger type for the system notification.

- **Event Type and Polarity** - Two trigger types of event detection are supported: edge and level. An edge event may be detected upon a source pin transition either from high to low or low to high. A level event may be detected when the source pin is in active level. The trigger type is determined by Event Type (bit 4). The direction of the transition (for edge) or the polarity of the active level (for level) is determined by Event Polarity (bit 5).
- **Event Debounce Enable** - The input signal can be debounced for about 15 msec before entering the detector. The signal state is transferred to the detector only after a debouncing period during which the signal has no transitions, to ensure that the signal is stable. The debouncer adds 15 msec delay to both assertion and de-assertion of the event pending indicator. Therefore, when working with a level event and system notification by either SMI or IRQ, it is recommended to disable the debounce if the delay in the $\overline{\text{SMI}}/\text{IRQ}$ de-assertion is not acceptable. The debounce is controlled by Event Debounce Enable (bit 6 of the SBGPIO Pin Configuration register).

3.4.31 Standby GPIO Pin Select Register (SBGPSEL)

This register selects the GPIOE/GPIE pin (port number and pin number) to be configured (the register accessed by the Standby GPIO Pin Configuration register). This register is reset to 00h on V_{PP} power-up or software reset.

When port 0 is selected, bits 2-0 select between pins GPIE7,6 and GPIOE5-0. When port 1 is selected, bits 2-0 select between pins GPOS0 and GPOS1. Pins GPIS2 and GPIS3 are input only and require no configuration.

Location: Bank 3, Offset 13h

Type: R/W

Bit	7	6	5	4	3	2	1	0
Name	Reserved			Port Select	Reserved	Pin Select		
Reset	0	0	0	0	0	0	0	0

Bit	Description
7-5	Reserved
4	Port Select. This bit selects the GPIO port to be configured. 0: Port 0 (default) 1: Port 1
3	Reserved
2-0	Pin Select. These bits select the GPIO pin to be configured in the selected port. 000, 001, ... 111: The binary value of the pin number, 0, 1, ... 7 respectively (default=0)

3.0 System Wake-Up Control (SWC) (Continued)

3.4.32 Standby GPIO Pin Configuration Register (SBGPCFG)

This is a group of twelve configuration registers. Eight are identical for GPIOE and GPIE, two are identical for GPOS, and two are identical for GPIS. Each GPIOE/GPIE register is associated with one GPIOE/GPIE pin, and each GPOS and GPIS register is associated with one GPOS or GPIS pin. The entire set is mapped to the same address. The mapping scheme is based on the Standby GPIO Pin Select (SBGPSEL) register that functions as an index register, and the specific Standby GPIO Pin Configuration register that reflects the configuration of the currently selected pin.

Bits 0-3 are applicable only for pins GPIOE0-5 and GPOS0,1. Bits 4-6 are applicable for all GPIOE/GPIE pins.

Location: Bank 3, Offset 14h

Type: R/W (bit 3 is set only)

For GPIOE and GPIE:

Bit	7	6	5	4	3	2	1	0
Name	Reserved	Event Debounce Enable	Event Polarity	Event Type	Lock	Pull-Up Control	Output Type	Output Enable
Reset	0	1	0	0	0	1	0	0

For GPOS:

Bit	7	6	5	4	3	2	1	0
Name	Reserved				Lock	Pull-Up Control	Output Type	Output Enable
Reset	0	0	0	0	0	1	0	1

For GPIS:

Bit	7	6	5	4	3	2	1	0
Name	Reserved							
Reset	0	0	0	0	0	0	0	0

Bit	Description
7	Reserved (for GPOS and GPIS, bits 7-4 and 7-0 are reserved, respectively)
6	Event Debounce Enable 0: Disabled 1: Enabled (default)
5	Event Polarity. This bit defines the polarity of the signal that causes a detection of an event from the corresponding GPIO pin. 0: Falling edge or low level input (default) 1: Rising edge or high level input
4	Event Type. This bit defines the signal type that causes a detection of an event from the corresponding GPIO pin. 0: Edge input (default) 1: Level input
3	Lock. This bit locks bits 2-0 of this register. These bits are associated with the GPIO pin currently selected by the SBGPSEL register. Once this bit is set to 1 by software, it can only be cleared to 0 by V _{SB} power-up reset. 0: No effect (default at V _{SB} power-up reset) 1: Direction, output type, pull-up and output value locked

3.0 System Wake-Up Control (SWC) (Continued)

Bit	Description
2	Pull-Up Control. This bit is used to enable/disable the internal pull-up capability of the corresponding GPIO pin. It supports open-drain output signals with internal pull-ups and TTL input signals. 0: Disabled 1: Enabled (default)
1	Output Type. This bit controls the output buffer type (open-drain or totem pole) of the corresponding GPIO pin. 0: Open-drain (default) 1: Push-pull
0	Output Enable. For GPOS, this is a R/O bit. It indicates the GPOS pin output state, and is always 1. For GPIOE and GPIE, this bit indicates the GPIO pin output state. It has no effect on input. 0: TRI-STATE (default for GPIOE/GPIE) 1: Output enabled (default for GPOS)

3.0 System Wake-Up Control (SWC) (Continued)

3.4.33 Standby GPIOE/GPIE Data Out Register 0 (SB_GPDO0)

This register is set to 3Fh on V_{PP} power-up or software reset, only when the Lock bit of the SBGPCFG register is set to 0. It determines the value to be driven on the GPIOE pins when configured as outputs.

Location: Offset 08h

Type: R/W

Bit	7	6	5	4	3	2	1	0
Name	Reserved		Data Out					
Reset	0	0	1	1	1	1	1	1

Bit	Description
7-6	Reserved
5	Data Out. Bits 5-0 correspond to pins GPIOE5-0 respectively. The value of each bit determines the value driven on the corresponding GPIOE pin when its output buffer is enabled. Writing to the bit latches the written data unless the bit is locked by the corresponding GPIOE Configuration Lock bit. Reading the bit returns its value, regardless of the pin value and configuration.
4	
3	
2	
1	
0	0: Corresponding pin level low when output enabled 1: Corresponding pin level high (according to buffer type and static pull-up selection) when output enabled

3.4.34 Standby GPIOE/GPIE Data In Register 0 (SB_GPDI0)

This register reflects the values of the GPIE7-6 and GPIOE5-0 pins. Write to this register is ignored.

Location: Offset 09h

Type: RO

Bit	7	6	5	4	3	2	1	0
Name	Data In							
Reset	X	X	X	X	X	X	X	X

Bit	Description
7	Data In. Bits 7-0 correspond to pins GPIE7-6 and GPIOE5-0 respectively. Reading each bit returns the value of the corresponding GPIE/GPIOE pin regardless of the pin configuration and the SB0_GPDO register value.
6	
5	
4	
3	
2	0: Corresponding pin level low 1: Corresponding pin level high
1	
0	

3.0 System Wake-Up Control (SWC) (Continued)

3.4.35 Standby GPOS Data Out Register 1 (SB_GPDO1)

This register is set to 03h on V_{PP} power-up or software reset, only when the Lock bit of the SBGPCFG register is set to 0. It determines the value to be driven on the GPSO0,1 pins.

Location: Offset 0Ah

Type: R/W

Bit	7	6	5	4	3	2	1	0
Name	Reserved						Data Out	
Reset	0	0	0	0	0	0	1	1

Bit	Description
7-2	Reserved
1-0	Data Out. Bits 1-0 correspond to pins GPOS1-0 respectively. The value of each bit determines the value driven on the corresponding GPOS pin when its output buffer is enabled. Writing to the bit latches the written data unless the bit is locked by the corresponding GPOS Configuration Lock bit. Reading the bit returns its value, regardless of the pin value and configuration. 0: Corresponding pin level low 1: Corresponding pin level high (according to buffer type and static pull-up selection)

3.4.36 Standby GPIS Data In Register 1 (SB_GPDI1)

This register reflects the values of the GPOS0,1 and GPIS2,3 pins. Write to this register is ignored.

Location: Offset 0Bh

Type: RO

Bit	7	6	5	4	3	2	1	0
Name	Reserved				Data In			
Reset	X	X	X	X	X	X	X	X

Bit	Description
7-4	Reserved
3-0	Data In. Reading each bit returns the value of the corresponding GPOS/GPIS pin. 0: Corresponding pin level low 1: Corresponding pin level high

3.0 System Wake-Up Control (SWC) (Continued)

3.5 SWC REGISTER BITMAP

Table 45. Banks 0 and 1 - The Common Register Bitmap

Register		Bits							
Offset	Mnemonic	7	6	5	4	3	2	1	0
00h	WK_STS0	Module IRQ Event Status	Software Event Status	GPIO Event Status	CEIR Event Status	Mouse Event Status	KBD Event Status	$\overline{RI2}$ Event Status	$\overline{RI1}$ Event Status
01h	WK_STS1	GPIE7 Event Status	GPIE6 Event Status	GPIE5 Event Status	GPIE4/RING Event Status	GPIE3 Event Status	GPIE2 Event Status	GPIE1 Event Status	GPIE0 Event Status
02h	WK_EN0	Module IRQ Event Enable	Software Event Enable	GPIO Event Enable	CEIR Event Enable	Mouse Event Enable	KBD Event Enable	$\overline{RI2}$ Event Enable	$\overline{RI1}$ Event Enable
03h	WK_EN1	GPIE7 Event Enable	GPIE6 Event Enable	GPIE5 Event Enable	GPIE4/RING Event Enable	GPIE3 Event Enable	GPIE2 Event Enable	GPIE1 Event Enable	GPIE0 Event Enable
04h	WK_CFG	Reserved				Enable Power Button Pulse on S3	Swap KBC Inputs	Configuration Bank Select	
05h-07h	Reserved								
08h	SB_GPDO0	Reserved			Data Out				
09h	SB_GPDI0	Data In							
0Ah	SB_GPDO1	Reserved						Data Out	
0Bh	SB_GPDI1	Reserved				Data In			
0Ch-12h	Reserved								

Table 46. Bank 0 - PS/2 Keyboard/Mouse Wake-Up Configuration and Control Registers Bitmap

Register		Bits							
Offset	Mnemonic	7	6	5	4	3	2	1	0
13h	PS2CTL	Disable Parity	Mouse Wake-Up Configuration			Keyboard Wake-Up Configuration			
16h	KDSR	Keyboard Data							
17h	MDSR	Reserved					Mouse Data		
18h-1Fh	PS2KEY0-PS2KEY7	Scan Code of Keys 0-7							

Table 47. Bank 1 - CEIR Wake-Up Configuration and Control Registers Bitmap

Register		Bits								
Offset	Mnemonic	7	6	5	4	3	2	1	0	
13h	IRWCR	Reserved			CEIR Protocol Select		Select IRRX2 Input	Invert IRRXn Input	Reserved	CEIR Enable
14h	Reserved									

3.0 System Wake-Up Control (SWC) (Continued)

15h	IRWAD	CEIR Wake-Up Address							
16h	IRWAM	CEIR Wake-Up Address Mask							
17h	ADSR	CEIR Address							
18h	IRWTR0L	Reserved	CEIR Pulse Change, Range 0, Low Limit						
19h	IRWTR0H	Reserved	CEIR Pulse Change, Range 0, High Limit						
1Ah	IRWTR1L	Reserved	CEIR Pulse Change, Range 1, Low Limit						
1Bh	IRWTR1H	Reserved	CEIR Pulse Change, Range 1, High Limit						
1Ch	IRWTR2L	CEIR Pulse Change, Range 2, Low Limit							
1Dh	IRWTR2H	CEIR Pulse Change, Range 2, High Limit							
1Eh	IRWTR3L	CEIR Pulse Change, Range 3, Low Limit							
1Fh	IRWTR3H	CEIR Pulse Change, Range 3, High Limit							

Table 48. Bank 2 - Event Routing Control Registers Bitmap

Register		Bits							
Offset	Mnemonic	7	6	5	4	3	2	1	0
13h	WK_SMIEN0	Reserved	Software Event to SMI Enable	Reserved	CEIR Event to SMI Enable	Mouse Event to SMI Enable	KBD Event to SMI Enable	R \bar{I} 2 Event to SMI Enable	R \bar{I} 1 Event to SMI Enable
14h	WK_SMIEN1	GPIE7 Event to SMI Enable	GPIE6 Event to SMI Enable	GPIE5 Event to SMI Enable	GPIE4/ RING Event to SMI Enable	GPIE3 Event to SMI Enable	GPIE2 Event to SMI Enable	GPIE1 Event to SMI Enable	GPIE0 Event to SMI Enable
15h	WK_IRQEN0	Reserved	Software Event to IRQ Enable	Reserved	CEIR Event to IRQ Enable	Mouse Event to IRQ Enable	KBD Event to IRQ Enable	R \bar{I} 2 Event to IRQ Enable	R \bar{I} 1 Event to IRQ Enable
16h	WK_IRQEN1	GPIE7 Event to IRQ Enable	GPIE6 Event to IRQ Enable	GPIE5 Event to IRQ Enable	GPIE4/ RING Event to IRQ Enable	GPIE3 Event to IRQ Enable	GPIE2 Event to IRQ Enable	GPIE1 Event to IRQ Enable	GPIE0 Event to IRQ Enable
17h	WK_X1EN0	Reserved			CEIR Event Ex. 1 Enable	Mouse Event Ex. 1 Enable	KBD Event Ex. 1 Enable	R \bar{I} 2 Event Ex. 1 Enable	R \bar{I} 1 Event Ex. 1 Enable
18h	WK_X1EN1	GPIE7 Event Ex. 1 Enable	GPIE6 Event Ex. 1 Enable	GPIE5 Event Ex. 1 Enable	GPIE4/ RING Event Ex. 1 Enable	GPIE3 Event Ex. 1 Enable	GPIE2 Event Ex. 1 Enable	GPIE1 Event Ex. 1 Enable	GPIE0 Event Ex. 1 Enable
19h	WK_X2EN0	Reserved			CEIR Event Ex. 2 Enable	Mouse Event Ex. 2 Enable	KBD Event Ex. 2 Enable	R \bar{I} 2 Event Ex. 2 Enable	R \bar{I} 1 Event Ex. 2 Enable
1Ah	WK_X2EN1	GPIE7 Event Ex. 2 Enable	GPIE6 Event Ex. 2 Enable	GPIE5 Event Ex. 2 Enable	GPIE4/ RING Event Ex. 2 Enable	GPIE3 Event Ex. 2 Enable	GPIE2 Event Ex. 2 Enable	GPIE1 Event Ex. 2 Enable	GPIE0 Event Ex. 2 Enable

3.0 System Wake-Up Control (SWC) (Continued)

1Bh	WK_X3EN0	Reserved			CEIR Event Ex. 3 Enable	Mouse Event Ex. 3 Enable	KBD Event Ex. 3 Enable	R $\bar{I}2$ Event Ex. 3 Enable	R $\bar{I}1$ Event Ex. 3 Enable
1Ch	WK_X3EN1	GPIE7 Event Ex. 3 Enable	GPIE6 Event Ex. 3 Enable	GPIE5 Event Ex. 3 Enable	GPIE4/ R $\bar{I}NG$ Event Ex. 3 Enable	GPIE3 Event Ex. 3 Enable	GPIE2 Event Ex. 3 Enable	GPIE1 Event Ex. 3 Enable	GPIE0 Event Ex. 3 Enable
1Dh- 1Fh	Reserved								

3.0 System Wake-Up Control (SWC) (Continued)

Bank 3 - Standby General-Purpose I/O Configuration Registers Bitmap

Register		Bits							
Offset	Mnemonic	7	6	5	4	3	2	1	0
13h	SBGPSEL	Reserved			Port Select	Reserved	Pin Select		
14h	SBGPCFG	Reserved	Event Debounce Enable	Event Polarity	Event Type	Lock	Pull-Up Control	Output Type	Output Enable
15h-1Fh	Reserved								

4.0 Fan Speed Control

4.1 OVERVIEW

This chapter describes a generic Fan Speed Control module. For the implementation used in this device, see the *Device Architecture and Configuration* chapter.

The Fan Speed Control is a programmable Pulse Width Modulation (PWM) generator. The PWM generator output is used to control the fan's power voltage, which is correlated to the fan's speed. Converting a 0 to 100% duty cycle PWM signal to an analog voltage range is achieved by an external circuit, as shown in Figure 13. Some newer fans accept direct PWM input without any external circuitry.

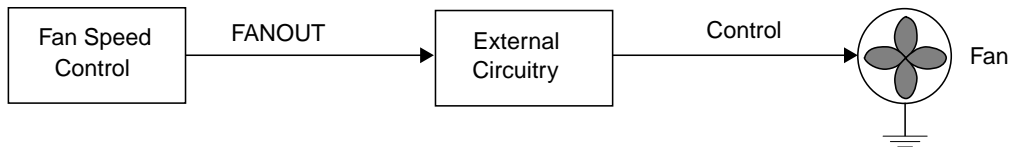

Figure 13. Fan Speed Control - System Configuration

4.2 FUNCTIONAL DESCRIPTION

The PWM generator operation is based on a PWM counter and two registers: the Fan Speed Control Pre-Scale register (FCPSR), used to determine the overall cycle time (or the frequency) of the FANOUT output, and the Fan Speed Control Duty Cycle register (FCDCR), used to determine the duty cycle of the FANOUT between 0 to 100%.

The PWM counter is an 8-bit, free-running counter that runs continuously in a cyclic manner, i.e its cycle equals 256 clock periods. The PWM output is high as long as the count is lower than the FCDCR value, and flips to low as the counter exceeds that value. The duty cycle (expressed as a percentage) is therefore $(FCDCR/256)*100$. In particular, the PWM output is continuously low when $FCDCR=0$ and continuously high when $FCDCR=FFh$. The FANOUT output may be inverted by an external configuration bit, in which case the FANOUT duty cycle is $([256-FCDCR]/256)*100$.

The PWM counter clock is generated by dividing the input clock, either 24 MHz or 200 KHz, using a clock divider. The division factor, which must be between 1 and 124, is defined as Pre-Scale Value+1, where Pre-Scale is the binary value stored in bits 6 to 0 of the FCPSR register. The resulting PWM output frequency is therefore:

$$(24 \text{ MHz or } 200 \text{ kHz}) / ([\text{Pre-Scale Value} + 1] * 256)$$

The default selection of 24 MHz input clock allows a programmable FANOUT frequency in the range of 756 Hz to 93.75 KHz. For lower frequencies, selecting the 200 KHz input clock allows a frequency range of 6 Hz to 781 Hz. See Figure 14.

The FANOUT frequency must be pre-selected according to the fan type's specific requirements prior to enabling the Fan Speed Control. The only run-time change that is required to dynamically control the fan speed is the value of the FCDCR register.

Warning! The contents of the FCPSR register must not be changed when the Fan Speed Control is enabled.

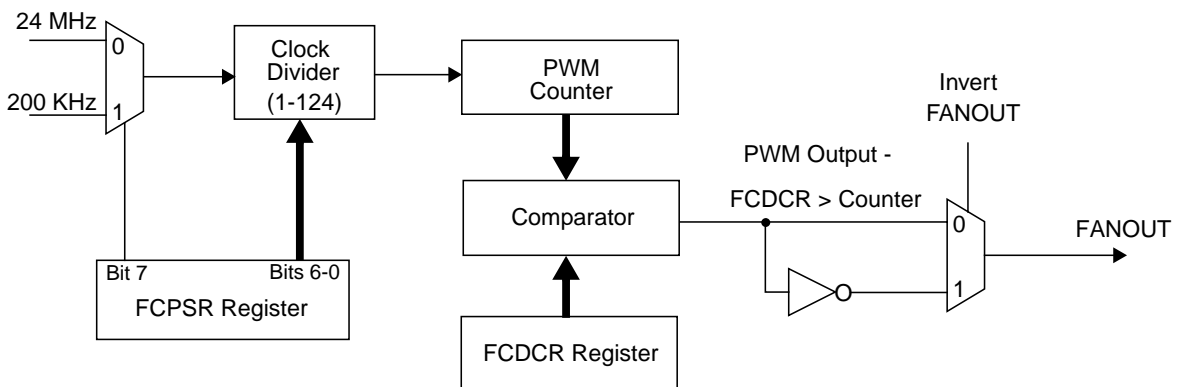

Figure 14. PWM Generator (FANOUT)

4.0 Fan Speed Control (Continued)

4.3 FAN SPEED CONTROL REGISTERS

The following abbreviations are used to indicate the Register Type:

- R/W = Read/Write
- R = Read from a specific address returns the value of a specific register. Write to the same address is to a different register.
- W = Write
- RO = Read Only
- R/W1C = Read/Write 1 to Clear. Writing 1 to a bit clears it to 0. Writing 0 has no effect.

4.3.1 Fan Speed Control Register Map

Offset	Mnemonic	Register Name	Type	Section
Device specific ^{Note 1.}	FCPSR	Fan Speed Control Pre-Scale	R/W	4.3.2
Device specific ^{Note 1.}	FCD CR	Fan Speed Control Duty Cycle	R/W	4.3.3

Note 1. The location of this register is defined in the *Device Architecture and Configuration* chapter.

4.3.2 Fan Speed Control Pre-Scale Register (FCPSR)

Location: Device specific

Type: R/W

Bit	7	6	5	4	3	2	1	0
Name	Clock Select	Pre-Scale Value						
Reset	0	0	0	0	0	0	0	0

Bit	Description
7	Clock Select. This bit selects the input clock for the clock divider. 0: 24 MHz 1: 200 KHz
6-0	Pre-Scale Value. The clock divider for the input clock (24 MHz or 200 KHz) is Pre-Scale Value + 1. Writing 0000000b to these bits transfers the input clock directly to the counter. The maximum clock divider is 124 (7Bh +1). These bits must not be programmed with the values 7Ch, 7Dh, 7Eh and 7Fh as this may produce unpredictable results. The contents of this register should not be changed when the corresponding Fan Speed Control Enable bit of the Fan Speed Control Configuration register is 1 (see <i>Device Architecture and Configuration</i> chapter) as this may produce unpredictable results.

4.0 Fan Speed Control (Continued)

4.3.3 Fan Speed Control Duty Cycle Register (FCDCR)

Location: Device specific

Type: R/W

Bit	7	6	5	4	3	2	1	0
Name	Duty Cycle Value							
Reset	1	1	1	1	1	1	1	1

Bit	Description
7-0	<p>Duty Cycle. The binary value of this 8-bit field determines the number of clock cycles, out of a 256-cycle period, during which the PWM output is high (while FANOUT is either equal to or the inverse of the PWM output, depending on the Inverse FANOUT configuration bit).</p> <p>00h: PWM output is continuously low</p> <p>01h - FEh: PWM output is high for [Duty Cycle Value] clock cycles and low for [256-Duty Cycle Value] clock cycles</p> <p>FFh: PWM output is continuously high</p>

4.4 FAN SPEED CONTROL BITMAP

Register		Bits							
Offset	Mnemonic	7	6	5	4	3	2	1	0
Device specific Note 1.	FCPSR	Clock Select	Pre-Scale Value						
Device specific Note 1.	FCDCR	Duty Cycle Value							

Note 1. The location of this register is defined in the *Device Architecture and Configuration* chapter.

5.0 Fan Speed Monitor

5.1 OVERVIEW

This chapter describes a generic Fan Speed Monitor module. For the implementation used in this device, see the *Device Architecture and Configuration* chapter.

The Fan Speed Monitor determines the fan's speed by measuring the time between consecutive tachometer pulses, emitted by the fan once or twice per revolution (depending on the fan type). It may provide the system with a current speed reading and/or alert the system, by interrupt, whenever the speed drops below a programmable threshold. The Fan Speed Monitor indicates whether the speed is just below the threshold or inefficiently low to consider the fan stopped.

Figure 15 shows the basic system configuration of the Fan Speed Monitor.

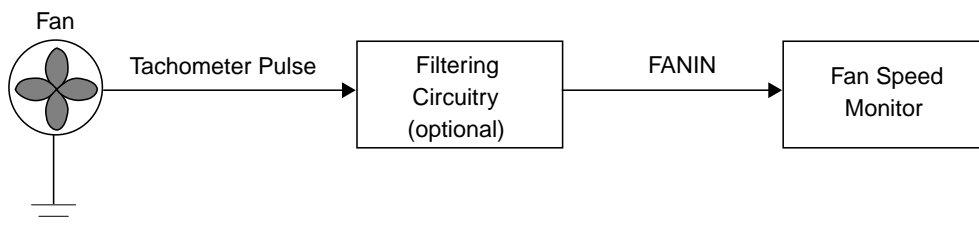

Figure 15. Fan Speed Monitor - System Configuration

5.2 FUNCTIONAL DESCRIPTION

The fan emits a tachometer pulse every half or full revolution (depending on the fan type). These pulses are fed into the Fan Speed Monitor through the FANIN input pin. Measuring the time between these pulses is the basis for speed monitoring.

NCBTP is defined as the Number of Clock-cycles Between consecutive Tachometer Pulses. For a known clock rate (f Hz) and number of pulses per revolution ($n=1,2$), the Fan Speed is calculated according to the following relationship:

$$\text{Fan Speed (in RPM)} = 60 \cdot \frac{f}{\text{NCBTP} \cdot n}$$

The Fan Speed Monitor consists of an 8-bit counter to measure the NCBTP and three 8-bit registers: Fan Monitor Speed register (FMSPR), Fan Monitor Threshold register (FMTHR) and Fan Monitor Control and Status register (FMCSR). Figure 16 is a general block diagram of the Fan Speed Monitor.

The Up Counter and the FMSPR register are cleared to 0 while the Fan Speed Monitor is disabled (and in particular upon system reset).

When the Fan Speed Monitor is enabled and there was no counter overflow, the counter runs (up-counts), clocked by the selected clock rate. Starting from the second FANIN pulse (after activation) and upon every rising edge of FANIN when the Over Threshold bit is 0, the FMSPR register is loaded with the contents of the counter, the counter is cleared to 0, and the Speed Ready bit is set to 1.

Upon reading FMSPR, the Speed Ready bit of the FMCSR is cleared to 0.

The above operation continually repeats itself, providing the host with the current speed reading, as long as the FMSPR register value is lower than the threshold.

Once the loaded FMSPR register value exceeds the threshold, the Over Threshold bit is set to 1. Interrupt is asserted if enabled. The FMSPR register is not loaded with any new values when the Over Threshold bit is set. A new value is loaded only after clearing the Over Threshold bit (by writing 1) and reading the FMSPR register. This guarantees that the same NCBTP value that generated the interrupt remains available for the interrupt handler.

If the counter passes FFh, the Overflow bit is set to 1, the FMSPR register is cleared, and the interrupt is asserted, if enabled. The Overflow bit is cleared to 0 when it is written with 1, after which speed measurement resumes.

The input buffer of the FANIN signal is a hysteresis buffer (Schmitt trigger). This signal passes through a digital filter when the Filter Disable bit (bit 4 of the FMCSR register) is 0. The digital filter uses a 32 KHz clock to filter out any pulses shorter than 750 μ sec. This filter can be by-passed when setting bit 4 of the FMCSR register to 1.

5.0 Fan Speed Monitor (Continued)

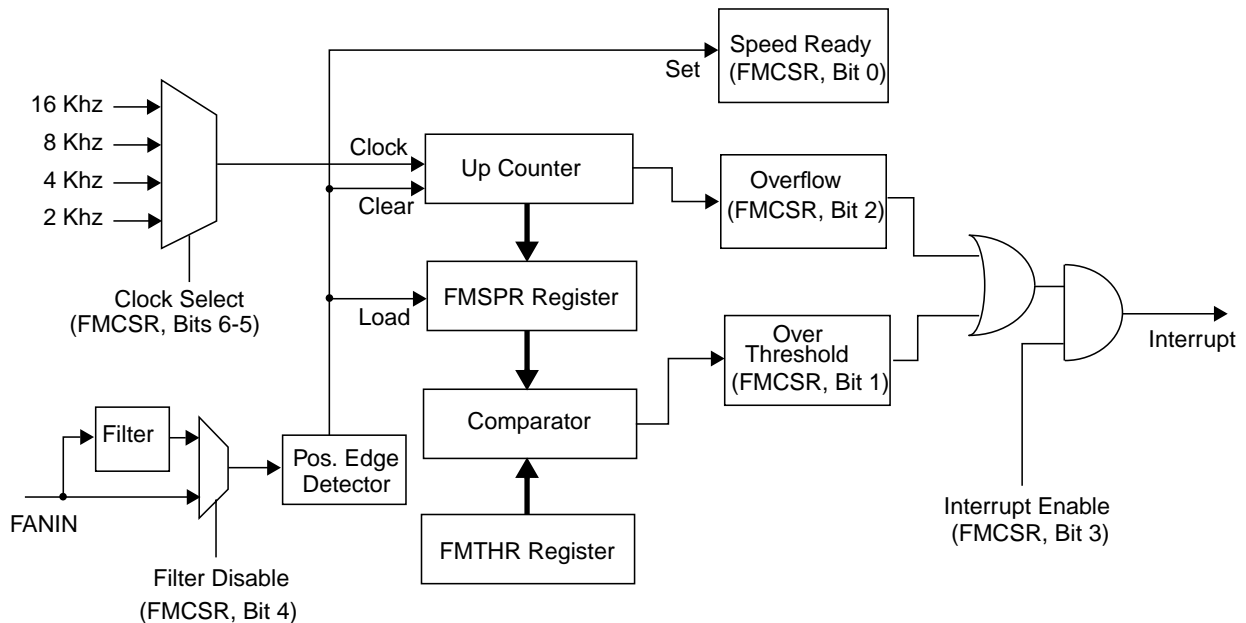

Figure 16. Fan Speed Monitor

5.3 FAN SPEED MONITOR REGISTERS

The FMSPR register is used to hold the current speed reading (which is represented by the latest NCBTP and refreshed upon every FANIN pulse).

The FMTHR register holds the maximum allowed NCBTP value (representing the slowest speed at which the fan is allowed to operate) without causing system alert.

Additional control and status bits are available through the FMCSR register. These include:

- Over Threshold. A status bit that indicates that the NCBTP has exceeded the threshold (the speed has dropped below the allowed minimum).
- Overflow. A status bit that indicates that the NCBTP is higher than FFh. With a proper input clock selection, this means that the speed is inefficiently low and is considered stopped.
- Speed Ready. A status bit that indicates that new, valid data has been loaded into the FMSPR register.
- Clock Select. A 2-bit control field that selects the counter clock rate as either 2 KHz, 4 KHz, 8 KHz or 16 KHz.

The following abbreviations are used to indicate the Register Type:

- R/W = Read/Write
- R = Read from a specific address returns the value of a specific register. Write to the same address is to a different register.
- W = Write
- RO = Read Only
- R/W1C = Read/Write 1 to Clear. Writing 1 to a bit clears it to 0. Writing 0 has no effect.

5.3.1 Fan Speed Monitor Register Map

Offset	Mnemonic	Register Name	Type	Section
Device specific ^{Note 1.}	FMTHR	Fan Monitor Threshold	R/W	5.3.2
Device specific ^{Note 1.}	FMSPR	Fan Monitor Speed	RO	5.3.3
Device specific ^{Note 1.}	FMCSR	Fan Monitor Control and Status	Varies per bit	5.3.4

Note 1. The location of this register is defined in the *Device Architecture and Configuration* chapter.

5.0 Fan Speed Monitor (Continued)

5.3.2 Fan Monitor Threshold Register (FMTHR)

This 8-bit register contains the programmable threshold for the fan. This threshold is the maximum number of clock cycles between consecutive tachometer pulses (frequencies of 16, 8, 4 or 2 KHz). It represents the minimum fan speed permitted in the system. If the period between consecutive tachometer pulses is greater than the threshold, an interrupt (if enabled) is issued. After reset, the value of FMTHR is FFh.

This register should not be changed when the corresponding Fan Monitor Enable bit is set to 1 (enabled), since this may cause unpredictable results.

Location: Device specific

Type: R/W

Bit	7	6	5	4	3	2	1	0
Name	Threshold Value							
Reset	1	1	1	1	1	1	1	1

5.3.3 Fan Monitor Speed Register (FMSPR)

This read-only 8-bit register holds the speed reading, represented by number of clock cycles between consecutive tachometer pulses. For details, refer to Section 5.2. When the Speed Ready bit of the FMCSR register is 1, FMSPR holds valid data that has not yet been read.

It is cleared to 00h upon any of the following conditions:

- System reset
- Fan Monitor Enable bit is set to 0
- Overflow bit is set to 1.

Location: Device specific

Type: RO

Bit	7	6	5	4	3	2	1	0
Name	Fan Speed Reading							
Reset	0	0	0	0	0	0	0	0

5.3.4 Fan Monitor Control and Status Register (FMCSR)

Location: Device specific

Type: Varies per bit

Bit	7	6	5	4	3	2	1	0
Name	Reserved	Clock Select		Filter Disable	Interrupt Enable	Overflow	Over Threshold	Speed Ready
Reset	0	0	1	0	0	0	0	0

5.0 Fan Speed Monitor (Continued)

Bit	Type	Description
7		Reserved
6-5	R/W	Clock Select. Selects the clock source provided to the counter. These bits must not be changed when the corresponding Fan Monitor Enable bit is 1 (enabled). 00: 16 KHz 01: 8 KHz (default) 10: 4 KHz 11: 2 KHz
4	R/W	Filter Disable. When this bit is set to 1, the digital filter is disabled. When it is cleared, the filter is enabled. This bit should not be changed when the corresponding Fan Monitor Enable bit is 1 (enabled) to avoid unpredictable results. 0: Digital filter enabled (default) 1: Digital filter disabled
3	R/W	Interrupt Enable. This bit controls the assertion of overflow interrupt and Over Threshold interrupt. 0: Interrupt disabled (default) 1: Interrupt enabled. Interrupt is asserted when an Over Threshold bit, Overflow bit or both are set to 1.
2	R/W1C	Overflow. Indicates that the counter has passed FFh, and the fan speed is inefficiently slow; i.e., slower than $60 * f / (256 * n)$. Writing 1 to this bit clears it to 0. 0: No overflow occurred since the last time this bit was cleared (by reset or by writing 1) 1: Counter passed FFh
1	R/W1C	Over Threshold. Indicates that the value loaded into the FMSPR register upon detection of the rising edge of the FANIN pulse exceeded the threshold value. 0: FMSPR register value did not exceed the threshold since the last time this bit was cleared (by reset or by writing 1) 1: FMSPR register value exceeded the threshold
0	RO	Speed Ready. This bit indicates that the speed register holds new (not yet read) and valid data. It is set to 1 on each rising edge of the FANIN input (starting from the second one) if the Over Threshold bit is 0. It is cleared to 0 whenever the speed register is read, or when the Overflow bit is set. 0: No new valid data in the FMSPR register (data is either invalid or has already been read) 1: FMSPR register loaded with new and valid data

5.4 FAN SPEED MONITOR BITMAP

Register		Bits							
Offset	Mnemonic	7	6	5	4	3	2	1	0
Device specific Note 1.	FMTHR	Threshold Value							
Device specific Note 1.	FMSPR	Fan Speed Reading							
Device specific Note 1.	FMCSR	Reserved	Clock Select		Filter Disable	Interrupt Enable	Overflow	Over Threshold	Speed Ready

Note 1. The location of this register is defined in the *Device Architecture and Configuration* chapter.

6.0 General-Purpose Input/Output (GPIO) Port

This chapter describes one 8-bit port. A device may include a combination of several ports with different implementations. For the device specific implementation, see the *Device Architecture and Configuration* chapter.

6.1 OVERVIEW

The GPIO port is an 8-bit port, which is based on eight pins. It features:

- Software capability to manipulate and read pin levels
- Controllable system notification by several means based on the pin level or level transition
- Ability to capture and manipulate events and their associated status
- Back-drive protected pins.

GPIO port operation is associated with two sets of registers:

- Pin Configuration registers, mapped in the Device Configuration space. These registers are used to statically set up the logical behavior of each pin. There are two 8-bit register for each GPIO pin.
- Four 8-bit runtime registers: GPIO Data Out (GPDO), GPIO Data In (GPD), GPIO Event Enable (GPEVEN) and GPIO Event Status (GPEVST). These registers are mapped in the GPIO device IO space (which is determined by the base address registers in the GPIO Device Configuration). They are used to manipulate and/or read the pin values, and to control and handle system notification. Each runtime register corresponds to the 8-pin port, such that bit n in each one of the four registers is associated with GPIOX n pin, where X is the port number.

Each GPIO pin is associated with ten configuration bits and the corresponding bit slice of the four runtime registers, as shown in Figure 17.

The functionality of the GPIO port is divided into basic functionality that includes the manipulation and reading of the GPIO pins, and enhanced functionality. The basic functionality is described in Section 6.2. The enhanced functionality which includes the event detection and system notification is described in Section 6.3.

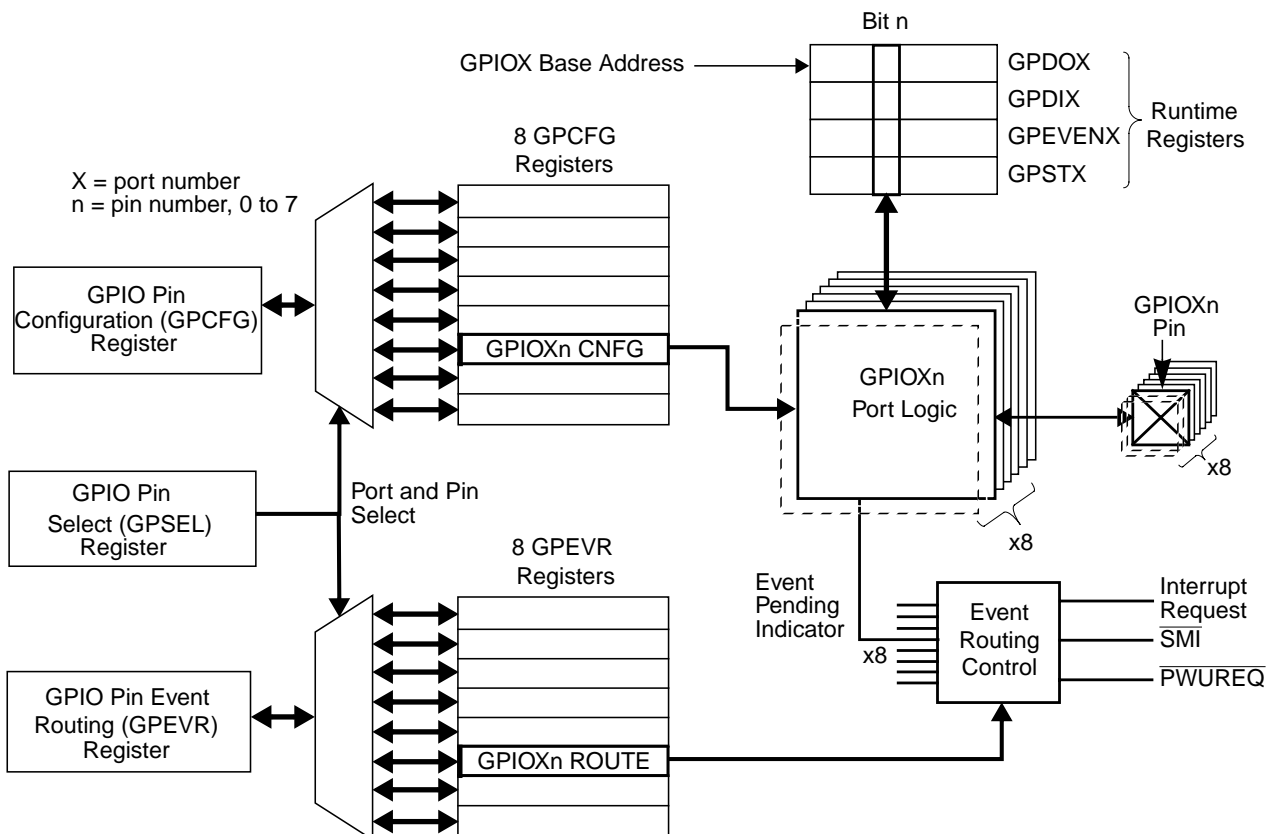

Figure 17. GPIO Port Architecture

6.0 General-Purpose Input/Output (GPIO) Port (Continued)

6.2 BASIC FUNCTIONALITY

The basic functionality of each GPIO pin is based on four configuration bits and a bit slice of runtime registers GPDO and GPDI. The configuration and operation of a single pin GPIOXn (pin n in port X) is shown in Figure 18.

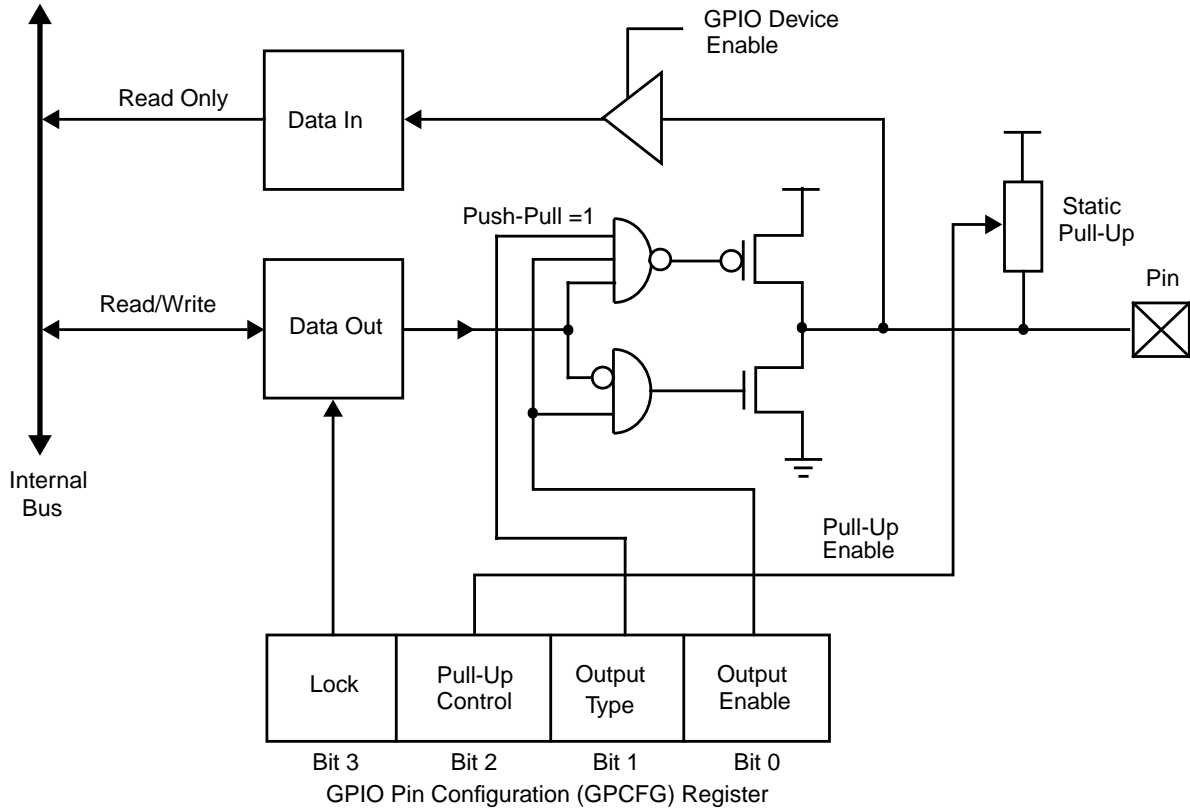

Figure 18. GPIO Basic Functionality

6.2.1 Configuration Options

The GPCFG register controls the following basic configuration options:

- Port Direction - Controlled by the Output Enable bit (bit 0)
- Output Type - Push-pull vs. open-drain. It is controlled by Output Buffer Type (bit 1) by enabling/disabling the pull-up portion of the output buffer.
- Weak Static Pull-up - May be added to any type of port (input, open-drain or push-pull). It is controlled by Pull-Up Control (bit 2).
- Pin Lock - GPIO pin may be locked to prevent any changes in the output value and/or the output characteristics. The lock is controlled by Lock (bit 3). It disables writes to the GPDO register bits, and to bits 0-3 of the GPCFG register (including the Lock bit itself). Once locked, it can be released by hardware reset only.

6.2.2 Operation

The value that is written to the GPDO register is driven to the pin, if the output is enabled. Reading from the GPDO register returns its contents, regardless of the pin value or the port configuration. The GPDI register is a read-only register. Reading from the GPDI register returns the pin value, regardless of what is driving it (the port itself, configured as an output port, or the external device when the port is configured as an input port). Writing to this register is ignored.

Activation of the GPIO port is controlled by external device specific configuration bit (or a combination of bits). When the port is inactive, access to GPDI and GPDO registers is disabled, and the inputs are blocked. However, there is no change in the port configuration and in the GPDO value, and hence there is no effect on the outputs of the pins.

6.0 General-Purpose Input/Output (GPIO) Port (Continued)

6.3 EVENT HANDLING AND SYSTEM NOTIFICATION

The enhanced GPIO port supports system notification based on event detection. This functionality is based on six configuration bits and a bit slice of runtime registers GPEVEN and GPST. The configuration and operation of the event detection capability is shown in Figure 19. The operation of system notification is illustrated in Figure 20.

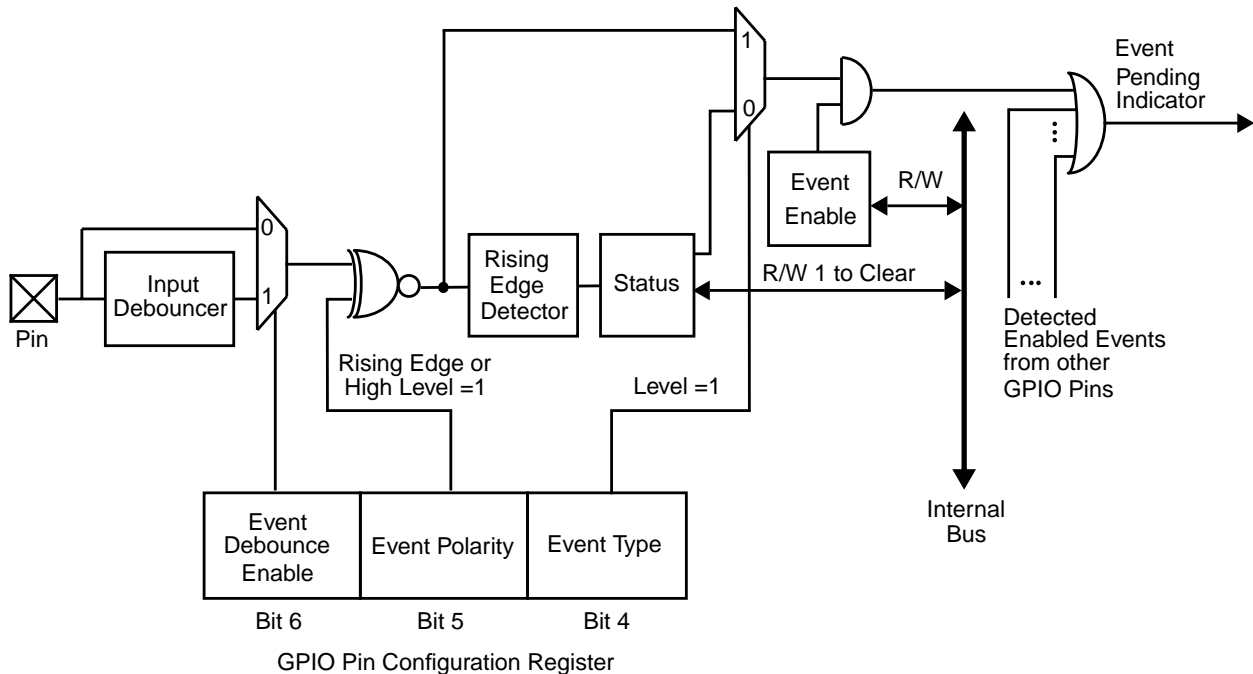

Figure 19. Event Detection

6.3.1 Event Configuration

Each pin in the GPIO port is a potential input event source. The event detection can trigger a system notification upon pre-determined behavior of the source pin. The GPCFG register determines the event detection trigger type for the system notification.

Event Type and Polarity

Two trigger types of event detection are supported: edge and level. An edge event may be detected upon a source pin transition either from high to low or low to high. A level event may be detected when the source pin is in active level. The trigger type is determined by Event Type (bit 4 of the GPCFG register). The direction of the transition (for edge) or the polarity of the active level (for level) is determined by Event Polarity (bit 5 of the GPCFG register).

Event Debounce Enable

The input signal can be debounced for about 15 msec before entering the detector. The signal state is transferred to the detector only after a debouncing period during which the signal has no transitions, to ensure that the signal is stable. The debouncer adds 15 msec delay to both assertion and de-assertion of the event pending indicator. Therefore, when working with a level event and system notification by either SMI or IRQ, it is recommended to disable the debounce if the delay in the SMI/IRQ de-assertion is not acceptable. The debounce is controlled by Event Debounce Enable (bit 6 of the GPCFG register).

6.3.2 System Notification

System notification on GPIO-triggered events is by means of assertion of one or more of the following output pins:

- Interrupt Request (via the device's Bus Interface)
- System Management Interrupt ($\overline{\text{SMI}}$, via the device's Bus Interface)
- Power-Up Request ($\overline{\text{PWUREQ}}$, via the System Wake-Up Control)

The system notification for each GPIO pin is controlled by the corresponding bits in the GPEVEN and GPEVR registers. System notification by a GPIO pin is enabled if the corresponding bit of the GPEVEN register is set to 1. The corresponding bits in the GPEVR register select which means of system notification the detected event is routed to. The event routing mechanism is described in Figure 20.

6.0 General-Purpose Input/Output (GPIO) Port (Continued)

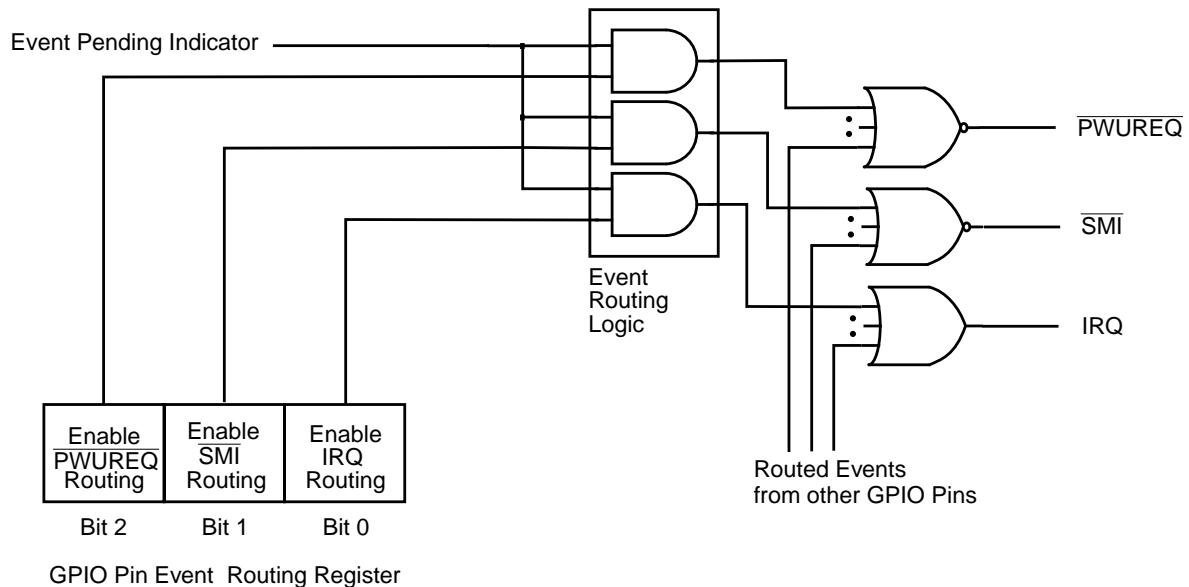

Figure 20. GPIO Event Routing Mechanism

The GPST register is a general-purpose edge detector which may be used to reflect the event source pending status for edge-triggered events.

The term *active edge* refers to a change in a GPIO pin level that matches the Event Polarity bit (1 for rising edge and 0 for falling edge). *Active level* refers to the GPIO pin level that matches the Event Polarity bit (1 for high level and 0 for low level). The corresponding bit of the GPST register is set by hardware whenever an active edge is detected, regardless of any other bit settings. Writing 1 to the Status bit clears it to 0. Writing 0 is ignored.

A GPIO pin is in event pending state if the corresponding bit of the GPEVEN register is set and either:

- The Event Type is level and the pin is in active level, or
- The Event Type is edge and the corresponding bit of the GPST register is set.

The target means of system notification is asserted if at least one GPIO pin is in event pending state.

The selection of the target means of system notification is determined by the GPEVR register. If IRQ is selected as one of the means for the system notification, the specific IRQ line is determined by the IRQ selection procedure of the device configuration. The assertion of any means of system notification is blocked when the GPIO functional block is deactivated.

If the output of a GPIO pin is enabled, it may be put in event pending state by the software when writing to the GPDO register.

A pending edge event may be cleared by clearing the corresponding GPST bit. However, a level event source may not be released by software (except for disabling the source), as long as the pin is in active level. When level event is used, it is recommended to disable the input debouncer.

Upon de-activation of the GPIO port, the GPST register is cleared and access to both the GPST and GPEVEN registers is disabled. All system notification means including the target IRQ line are detached from the GPIO and de-asserted.

Before enabling any system notification, it is recommended to set the desired event configuration, and then verify that the status registers are cleared.

6.4 GPIO PORT REGISTERS

The register maps in this chapter use the following abbreviations for Type:

- R/W = Read/Write
- R = Read from a specific address returns the value of a specific register. Write to the same address is to a different register.
- W = Write
- RO = Read Only
- R/W1C = Read/Write 1 to Clear. Writing 1 to a bit clears it to 0. Writing 0 has no effect.

6.0 General-Purpose Input/Output (GPIO) Port (Continued)

6.4.1 GPIO Pin Configuration (GPCFG) Register

This is a group of eight identical configuration registers, each of which is associated with one GPIO pin. The entire set is mapped to the PnP configuration space. The mapping scheme is based on the GPSEL register that functions as an index register, and the specific GPCFG register that reflects the configuration of the currently selected pin. For details on the GPSEL register, refer to the *Device Architecture and Configuration* chapter.

Bits 4-6 are applicable only for the enhanced GPIO port with event detection support. In the basic port, these bits are reserved, return 0 on read and have no effect on port functionality.

Location: Device specific

Type: R/W (bit 3 is set only)

Bit	7	6	5	4	3	2	1	0
Name	Reserved	Event Debounce Enable	Event Polarity	Event Type	Lock	Pull-Up Control	Output Type	Output Enable
Reset	0	1	0	0	0	1	0	0

Bit	Description
7	Reserved
6	Event Debounce Enable 0: Disabled 1: Enabled (default)
5	Event Polarity. This bit defines the polarity of the signal that causes a detection of an event from the corresponding GPIO pin (falling/low or rising/high). 0: Falling edge or low level input (default) 1: Rising edge or high level input
4	Event Type. This bit defines the signal type that causes a detection of an event from the corresponding GPIO pin. 0: Edge input (default) 1: Level input
3	Lock. This bit locks the corresponding GPIO pin. Once this bit is set to 1 by software, it can only be cleared to 0 by system reset or power-off. Pin multiplexing is functional until the Multiplexing Lock bit is 1. (Refer to the <i>Device Architecture and Configuration</i> chapter.) 0: No effect (default) 1: Direction, output type, pull-up and output value locked
2	Pull-Up Control. This bit is used to enable/disable the internal pull-up capability of the corresponding GPIO pin. It supports open-drain output signals with internal pull-ups and TTL input signals 0: Disabled 1: Enabled (default)
1	Output Type. This bit controls the output buffer type (open-drain or push-pull) of the corresponding GPIO pin. 0: Open-drain (default) 1: Push-pull
0	Output Enable. This bit indicates the GPIO pin output state. It has no effect on input. 0: TRI-STATE (default) 1: Output enabled

6.0 General-Purpose Input/Output (GPIO) Port (Continued)

6.4.2 GPIO Pin Event Routing (GPEVR) Register

This is a group of eight identical configuration registers, each of which is associated with one GPIO pin. The entire set is mapped to the PnP configuration space. The mapping scheme is based on the GPSEL register that functions as an index register, and the specific GPER register that reflects the routing configuration of the currently selected pin. For details on the GPSEL register, refer to the *Device Architecture and Configuration* chapter.

This set of registers is applicable only for the enhanced GPIO port with event detection support. In the basic port this register set is reserved, returns 0 on read and has no effect on port functionality.

Location: Device specific

Type: R/W

Bit	7	6	5	4	3	2	1	0
Name	Reserved					GPIO Event to PWUREQ Enable	GPIO Event to SMI Enable	GPIO Event to IRQ Enable
Reset	0	0	0	0	0	0	0	1

Bit	Description
7-3	Reserved
2	GPIO Event to PWUREQ Enable. This bit is used to enable/disable the routing of the corresponding GPIO detected event to PWUREQ. 0: Disabled (default) 1: Enabled
1	GPIO Event to SMI Enable. This bit is used to enable/disable the routing of the corresponding GPIO detected event to SMI. 0: Disabled (default) 1: Enabled
0	GPIO Event to IRQ Enable. This bit is used to enable/disable the routing of the corresponding GPIO detected event to IRQ. 0: Disabled 1: Enabled (default)

6.4.3 GPIO Port Runtime Register Map

Offset	Mnemonic	Register Name	Type	Section
Device specific ^{Note 1.}	GPDO	GPIO Data Out	R/W	6.4.4
Device specific ^{Note 1.}	GPDI	GPIO Data In	RO	6.4.5
Device specific ^{Note 1.}	GPEVEN	GPIO Event Enable	R/W	6.4.6
Device specific ^{Note 1.}	GPEVST	GPIO Event Status	R/W1C	6.4.7

Note 1. The location of this register is defined in the *Device Architecture and Configuration* chapter in Section 2.15.1.

6.0 General-Purpose Input/Output (GPIO) Port (Continued)

6.4.4 GPIO Data Out Register (GPDO)

Location: Device specific

Type: R/W

Bit	7	6	5	4	3	2	1	0
Name	Data Out							
Reset	1	1	1	1	1	1	1	1

Bit	Description
7	<p>Data Out. Bits 7-0 correspond to pins 7-0 respectively. The value of each bit determines the value driven on the corresponding GPIO pin when its output buffer is enabled. Writing to the bit latches the written data unless the bit is locked by the GPCFG register Lock bit. Reading the bit returns its value, regardless of the pin value and configuration.</p> <p>0: Corresponding pin driven to low when output enabled</p> <p>1: Corresponding pin driven or released to high (according to buffer type and static pull-up selection) when output enabled</p>
6	
5	
4	
3	
2	
1	
0	

6.4.5 GPIO Data In Register (GPI)

Location: Device specific

Type: RO

Bit	7	6	5	4	3	2	1	0
Name	Data In							
Reset	X	X	X	X	X	X	X	X

Bit	Description
7	<p>Data In. Bits 7-0 correspond to pins 7-0 respectively. Reading each bit returns the value of the corresponding GPIO pin, regardless of the pin configuration and the GPDO register value. Write is ignored.</p> <p>0: Corresponding pin level low</p> <p>1: Corresponding pin level high</p>
6	
5	
4	
3	
2	
1	
0	

6.0 General-Purpose Input/Output (GPIO) Port (Continued)

6.4.6 GPIO Event Enable Register (GPEVEN)

Location: Device specific

Type: R/W

Bit	7	6	5	4	3	2	1	0
Name	Event Enable							
Reset	0	0	0	0	0	0	0	0

Bit	Description
7	<p>Event Enable. Bits 7-0 correspond to pins 7-0 respectively. Each bit enables system notification triggering by the corresponding GPIO pin. The bit has no effect on the corresponding Status bit in the GPST register.</p> <p>0: IRQ generation by corresponding GPIO pin masked 1: IRQ generation by corresponding GPIO pin enabled</p>
6	
5	
4	
3	
2	
1	
0	

6.4.7 GPIO Event Status Register (GPEVST)

Location: Device specific

Type: R/W1C

Bit	7	6	5	4	3	2	1	0
Name	Status							
Reset	0	0	0	0	0	0	0	0

Bit	Description
7	<p>Status. Bits 7-0 correspond to pins 7-0 respectively. Each bit is an edge detector that is set to 1 by the hardware upon detection of an active edge (i.e. edge that matches the IRQ Polarity bit) on the corresponding GPIO pin. This edge detection is independent of the Event Type or the Event Enable bit in the GPEVEN register. However, the bit may reflect the event status for enabled, edge-trigger event sources. Writing 1 to the Status bit clears it to 0.</p> <p>0: No active edge detected since last cleared 1: Active edge detected</p>
6	
5	
4	
3	
2	
1	
0	

7.0 WATCHDOG Timer (WDT)

7.1 OVERVIEW

The WATCHDOG Timer prompts the system via SMI or interrupt when no system activity is detected on a predefined selection of system events for a predefined period of time (1 to 255 minutes).

The WATCHDOG Timer monitors four maskable system events: the interrupt request lines of the Keyboard, Mouse and the two serial ports (UART1 and UART2). The system prompt is performed by asserting a special-purpose output pin (\overline{WDO}), which can be attached to external SMI. Alternatively, this indication can be routed to any arbitrary IRQ line and is also available on a status bit that can be read by the host.

This chapter describes the generic WATCHDOG Timer functional block. A device may include a different implementation. For device specific implementation, see the *Device Architecture and Configuration* chapter.

7.2 FUNCTIONAL DESCRIPTION

The WATCHDOG Timer consists of an 8-bit counter and three registers: Timeout register (WDTO), Mask register (WDMSK) and Status register (WDST). The counter is an 8-bit down counter that is clocked every minute and is used for the timeout period countdown. The WDTO register holds the programmable timeout, which is the period of inactivity after which the WATCHDOG Timer prompts the system (1 to 255 minutes). The WDMSK register determines which system events are enabled as WATCHDOG Timer trigger events to restart the countdown. The WDST register holds the WATCHDOG Timer status bit that reflects the value of the \overline{WDO} pin and indicates that the timeout period has expired.

Figure 21 shows the functionality of the WATCHDOG Timer.

Upon reset, the Timeout register (WDTO) is initialized to zero, the timer is deactivated, the \overline{WDO} is inactive (high) and all trigger events are masked.

Upon writing to the WDTO register, the timer is activated while the counter is loaded with the timeout value and starts counting down every minute. If a trigger event (unmasked system event) occurs before the counter has expired (reached zero), the counter is reloaded with the timeout period (from WDTO register) and restarts the countdown. If no trigger event occurs before the timeout period expires, the counter reaches zero and stops counting. Consequently, the \overline{WDO} pin is asserted (pulled low) and the \overline{WDO} Status bit is cleared to 0.

Writing to the WDTO register de-asserts the \overline{WDO} output (released high) and sets the \overline{WDO} Status bit to 1. If a non-zero value is written, a new countdown starts as described above. If 00h is written, the timer is deactivated.

To summarize, the \overline{WDO} output is de-asserted (high) and the Status bit is set to 1 (inactive) upon:

- Reset,
- Activating the WATCHDOG Timer or
- Writing to the WDTO register.

The \overline{WDO} output is asserted (low) and the \overline{WDO} status is set to zero (active) when the counter reaches zero.

When an IRQ is assigned to the WATCHDOG Timer (through the WATCHDOG Timer device configuration), the selected IRQ level is active as long as the \overline{WDO} status bit is low (active).

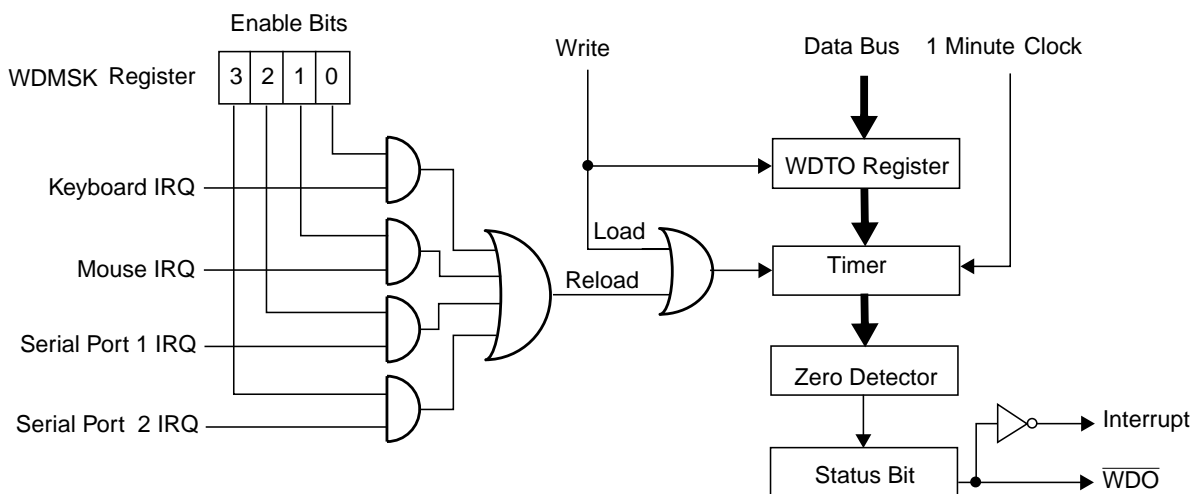

Figure 21. WATCHDOG Timer Functional Diagram

7.0 WATCHDOG Timer (WDT) (Continued)

7.3 WATCHDOG TIMER REGISTERS

The WATCHDOG Timer registers at offsets 00h-02h relative to the WATCHDOG base address, are shown in the following register map. The base address is defined by designated registers in the WATCHDOG Timer device configuration register set.

The following abbreviations are used to indicate the Register Type:

- R/W = Read/Write
- R = Read from a specific address returns the value of a specific register. Write to the same address is to a different register.
- W = Write
- RO = Read Only
- R/W1C = Read/Write 1 to Clear. Writing 1 to a bit clears it to 0. Writing 0 has no effect.

7.3.1 WATCHDOG Timer Register Map

Offset	Mnemonic	Register Name	Type	Section
00h	WDTO	WATCHDOG Timeout	R/W	7.3.2
01h	WDMSK	WATCHDOG Mask	R/W	7.3.3
02h	WDST	WATCHDOG Status	RO	7.3.4
03h		Reserved		

7.3.2 WATCHDOG Timeout Register (WDTO)

This register holds the programmable timeout period, between 1 and 255 minutes. Writing to this register de-asserts the \overline{WDO} output and sets the \overline{WDO} status bit to 1 (inactive). Additionally, writing to this register is interpreted as a command for starting or stopping the WATCHDOG Timer, according to the data written. If a non-zero value is written, the timer is activated (countdown starts). If a non-zero value is written when the counter is running, the timer is immediately reloaded with the new value and starts counting down from the new value. If 00h is written, the timer and its outputs are de-activated.

Location: Offset 00h

Type: R/W

Bit	7	6	5	4	3	2	1	0
Name	Programmed Timeout Period							
Reset	0	0	0	0	0	0	0	0

Bit	Description
7-0	Programmed Timeout Period. These bits hold the binary value of the timeout period in minutes (1 to 255). A value of 00h halts the counter and forces the outputs to inactive levels. A device reset clears the register to 00h. 00h: Timer and \overline{WDO} outputs inactive 01h-FFh: Programmed timeout period (in minutes)

7.0 WATCHDOG Timer (WDT) (Continued)

7.3.3 WATCHDOG Mask Register (WDMSK)

This register is used to determine which system events (IRQ) are enabled as WATCHDOG Timer trigger events. An enabled IRQ event becomes a trigger event that causes the timer to reload the WDTO and restart the countdown.

This register enables or masks the trigger events that restart the WATCHDOG timer.

Location: Offset 01h

Type: R/W

Bit	7	6	5	4	3	2	1	0
Name	Reserved				Serial Port 2 IRQ Trigger Enable	Serial Port 1 IRQ Trigger Enable	Mouse IRQ Trigger Enable	KBD IRQ Trigger Enable
Reset	0	0	0	0	0	0	0	0

Bit	Description
7-4	Reserved
3	Serial Port 2 IRQ Trigger Enable. This bit enables the IRQ assigned to Serial Port 2 to trigger WATCHDOG Timer reloading. 0: Serial Port 2 IRQ not a trigger event 1: An active Serial Port 2 IRQ enabled as a trigger event
2	Serial Port 1 IRQ Trigger Enable. This bit enables the IRQ assigned to Serial Port 1 to trigger WATCHDOG Timer reloading. 0: Serial Port 1 IRQ not a trigger event 1: An active Serial Port 1 IRQ enabled as a trigger event
1	Mouse IRQ Trigger Enable. This bit enables the IRQ assigned to the Mouse to trigger WATCHDOG Timer reloading. 0: Mouse IRQ not a trigger event 1: An active Mouse IRQ enabled as a trigger event
0	KBD IRQ Trigger Enable. This bit enables the IRQ assigned to the Keyboard to trigger reloading of the WATCHDOG timer. 0: Keyboard IRQ not a trigger event 1: An active Keyboard IRQ enabled as a trigger event

7.0 WATCHDOG Timer (WDT) (Continued)

7.3.4 WATCHDOG Status Register (WDST)

This register holds the WATCHDOG Timer status, which reflects the value of the \overline{WDO} pin and indicates that the timeout period has expired.

On reset or on WATCHDOG Timer activation, this register is initialized to 01h.

Location: Offset 02h

Type: RO

Bit	7	6	5	4	3	2	1	0
Name	Reserved							\overline{WDO} Value
Reset	0	0	0	0	0	0	0	1
Required	0							

Bit	Description
7-1	Reserved
0	\overline{WDO} Value. This bit reflects the value of the \overline{WDO} signal (even if \overline{WDO} is not configured for output). 0: \overline{WDO} active 1: \overline{WDO} inactive (default)

7.4 WATCHDOG TIMER REGISTER BITMAP

Register		Bits							
Offset	Mnemonic	7	6	5	4	3	2	1	0
00h	WDTO	Programmed Timeout Period							
01h	WDMSK	Reserved				Serial Port 2 IRQ Trigger Enable	Serial Port 1 IRQ Trigger Enable	Mouse IRQ Trigger Enable	KBD IRQ Trigger Enable
02h	WDST	Reserved							\overline{WDO} Value

8.0 ACCESS.bus Interface (ACB)

The ACB is a two-wire synchronous serial interface compatible with the ACCESS.bus physical layer. The ACB is also compatible with Intel's SMBus and Philips' I²C. The ACB can be configured as a bus master or slave, and can maintain bi-directional communication with both multiple master and slave devices. As a slave device, the ACB may issue a request to become the bus master.

The ACB allows easy interfacing to a wide range of low-cost memories and I/O devices, including EEPROMs, SRAMs, timers, ADC, DAC, clock chips and peripheral drivers.

This chapter describes the general ACB functional block. A device may include a different implementation. For device specific implementation, see the *Device Architecture and Configuration* chapter.

8.1 OVERVIEW

The ACCESS.bus protocol uses a two-wire interface for bi-directional communication between the devices connected to the bus. The two interface lines are the Serial Data Line (SDL) and the Serial Clock Line (SCL). These lines should be connected to a positive supply via an internal or external pull-up resistor, and remain high even when the bus is idle.

Each IC has a unique address and can operate as a transmitter or a receiver (though some peripherals are only receivers).

During data transactions, the master device initiates the transaction, generates the clock signal and terminates the transaction. For example, when the ACB initiates a data transaction with an attached ACCESS.bus compliant peripheral, the ACB becomes the master. When the peripheral responds and transmits data to the ACB, their master/slave (data transaction initiator and clock generator) relationship is unchanged, even though their transmitter/receiver functions are reversed.

8.2 FUNCTIONAL DESCRIPTION

8.2.1 Data Transactions

One data bit is transferred during each clock pulse. Data is sampled during the high state of the serial clock (SCL). Consequently, throughout the clock's high period, the data should remain stable (see Figure 22). Any changes on the SDA line during the high state of the SCL and in the middle of a transaction aborts the current transaction. New data should be sent during the low SCL state. This protocol permits a single data line to transfer both command/control information and data, using the synchronous serial clock.

Each data transaction is composed of a Start Condition, a number of byte transfers (set by the software) and a Stop Condition to terminate the transaction. Each byte is transferred with the most significant bit first, and after each byte (8 bits), an Acknowledge signal must follow. The following sections provide further details of this process.

During each clock cycle, the slave can stall the master while it handles the received data or prepares new data. This can be done for each bit transferred, or on a byte boundary, by the slave holding SCL low to extend the clock-low period. Typically, slaves extend the first clock cycle of a transfer if a byte read has not yet been stored, or if the next byte to be transmitted is not yet ready. Some microcontrollers, with limited hardware support for ACCESS.bus, extend the access after each bit, thus allowing the software to handle this bit.

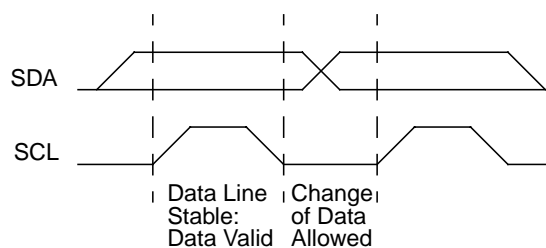

Figure 22. Bit Transfer

8.2.2 Start and Stop Conditions

The ACCESS.bus master generates Start and Stop Conditions (control codes). After a Start Condition is generated, the bus is considered busy and retains this status for a certain time after a Stop Condition is generated. A high to low transition of the data line (SDA) while the clock (SCL) is high indicates a Start Condition. A low to high transition of the SDA line while the SCL is high indicates a Stop Condition (Figure 23). After a Stop Condition is issued, the data in the received buffer is not valid.

In addition to the first Start Condition, a repeated Start Condition can be generated in the middle of a transaction. This allows another device to be accessed, or a change in the direction of data transfer.

8.0 ACCESS.bus Interface (ACB) (Continued)

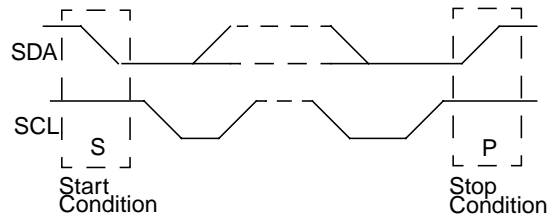

Figure 23. Start and Stop Conditions

8.2.3 Acknowledge (ACK) Cycle

The ACK cycle consists of two signals: the ACK clock pulse sent by the master with each byte transferred, and the ACK signal sent by the receiving device (see Figure 24).

The master generates the ACK clock pulse on the ninth clock pulse of the byte transfer. The transmitter releases the SDA line (permits it to go high) to allow the receiver to send the ACK signal. The receiver must pull down the SDA line during the ACK clock pulse, signalling that it has correctly received the last data byte and is ready to receive the next byte. Figure 25 illustrates the ACK cycle.

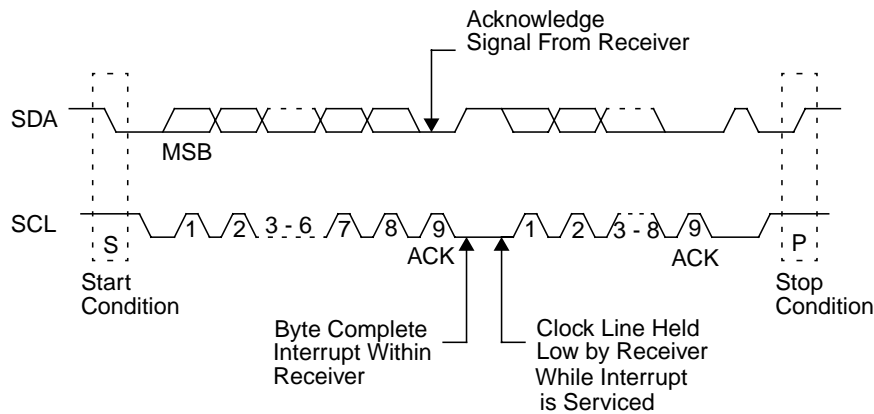

Figure 24. ACCESS.bus Data Transaction

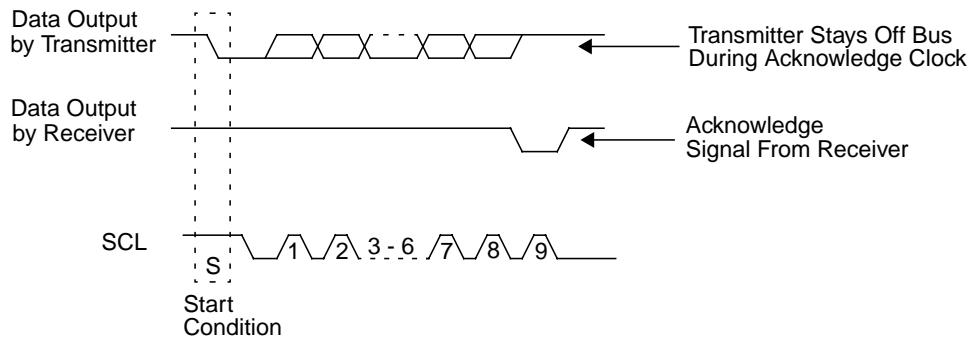

Figure 25. ACCESS.bus Acknowledge Cycle

8.0 ACCESS.bus Interface (ACB) (Continued)

8.2.4 Acknowledge after Every Byte Rule

According to this rule, the master generates an acknowledge clock pulse after each byte transfer, and the receiver sends an acknowledge signal after every byte received. There are two exceptions to this rule:

1. When the master is the receiver, it must indicate to the transmitter the end of data by not acknowledging (negative acknowledge) the last byte clocked out of the slave. This negative acknowledge still includes the acknowledge clock pulse (generated by the master), but the SDA line is not pulled down.
2. When the receiver is full, otherwise occupied, or a problem has occurred, it sends a negative acknowledge to indicate that it cannot accept additional data bytes.

8.2.5 Addressing Transfer Formats

Each device on the bus has a unique address. Before any data is transmitted, the master transmits the address of the slave being addressed. The slave device should send an acknowledge signal on the SDA line once it recognizes its address.

The address consists of the first 7 bits after a Start Condition. The direction of the data transfer (R/\bar{W}) depends on the bit sent after the address, the eighth bit. A low to high transition during a SCL high period indicates the Stop Condition, and ends the transaction of SDA (see Figure 26).

When the address is sent, each device in the system compares this address with its own. If there is a match, the device considers itself addressed and sends an acknowledge signal. Depending on the state of the R/\bar{W} bit (1=read, 0=write), the device acts either as a transmitter or a receiver.

The I^2C bus protocol allows a general call address to be sent to all slaves connected to the bus. The first byte sent specifies the general call address (00h) and the second byte specifies the meaning of the general call (for example, write slave address by software only). Those slaves that require data acknowledge the call, and become slave receivers; other slaves ignore the call.

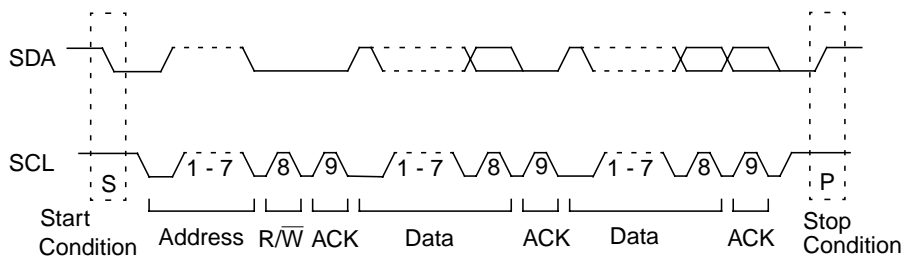

Figure 26. A Complete ACCESS.bus Data Transaction

8.2.6 Arbitration on the Bus

Multiple master devices on the bus require arbitration between their conflicting bus access demands. Control of the bus is initially determined according to address bits and clock cycle. If the masters are trying to address the same slave, data comparisons determine the outcome of this arbitration. In master mode, the device immediately aborts a transaction if the value sampled on the SDA line differs from the value driven by the device. (An exception to this rule is SDA while receiving data. The lines may be driven low by the slave without causing an abort.)

The SCL signal is monitored for clock synchronization and to allow the slave to stall the bus. The actual clock period is set by the master with the longest clock period, or by the slave stall period. The clock high period is determined by the master with the shortest clock high period.

When an abort occurs during the address transmission, a master that identifies the conflict should give up the bus, switch to slave mode and continue to sample SDA to check if it is being addressed by the winning master on the bus.

8.0 ACCESS.bus Interface (ACB) (Continued)

8.2.7 Master Mode

Requesting Bus Mastership

An ACCESS.bus transaction starts with a master device requesting bus mastership. It asserts a Start Condition, followed by the address of the device it wants to access. If this transaction is successfully completed, the software may assume that the device has become the bus master.

For the device to become the bus master, the software should perform the following steps:

1. Configure the INTEN bit of the ACBCTL1 register to the desired operation mode (Polling or Interrupt) and set the START bit of this register. This causes the ACB to issue a Start Condition on the ACCESS.bus when the ACCESS.bus becomes free (BB bit of the ACBCST register is cleared, or other conditions that can delay start). It then stalls the bus by holding SCL low.
2. If a bus conflict is detected (i.e., another device pulls down the SCL signal), the BER bit of the ACBST register is set.
3. If there is no bus conflict, the MASTER bit of the ACBST register and the SCAST of the ACBST register are set.
4. If the INTEN bit of the ACBCTL1 register is set and either the BER or SDAST bit of the ACBST register is set, an interrupt is issued.

Sending the Address Byte

When the device is the active master of the ACCESS.bus (the MASTER bit of the ACBST register is set), it can send the address on the bus.

The address sent should not be the device's own address, as defined by the ADDR bit of the ACBADDR register if the SAEN bit of this register is set, nor should it be the global call address if the GCMTCH bit of the ACBCST register is set.

To send the address byte, use the following sequence:

1. For a receive transaction where the software wants only one byte of data, it should set the ACB bit of the ACBCTL1 Register. If only an address needs to be sent or if the device requires stall for some other reason, set the STASTRE bit of the ACBCTL1 register.
2. Write the address byte (7-bit target device address) and the direction bit to the ACBSDA register. This causes the ACB to generate a transaction. At the end of this transaction, the acknowledge bit received is copied to the NEGACK bit of the ACBST register. During the transaction, the SDA and SCL lines are continuously checked for conflict with other devices. If a conflict is detected, the transaction is aborted, the BER bit of the ACBST register is set and the MASTER bit of this register is cleared.
3. If the STASTRE bit of the ACBCTL1 register is set and the transaction was successfully completed (i.e., both the BER and NEGACK bits of the ACBST register are cleared), the STASTR bit is set. In this case, the ACB stalls any further ACCESS.bus operations (i.e., holds SCL low). If the INTEN bit of the ACBCTL1 register is set, it also sends an interrupt request to the host.
4. If the requested direction is transmit and the start transaction was completed successfully (i.e., neither the NEGACK nor the BER bit of the ACBST register is set, and no other master has accessed the device), the SDAST bit of the ACBST register is set to indicate that the ACB awaits attention.
5. If the requested direction is receive, the start transaction was completed successfully and the STASTRE bit of the ACBCTL1 register is cleared, the ACB starts receiving the first byte automatically.
6. Check that both the BER and NEGACK bits of the ACBST register are cleared. If the INTEN bit of the ACBCTL1 register is set, an interrupt is generated when either the BER or NEGACK bit of the ACBST register is set.

Master Transmit

After becoming the bus master, the device can start transmitting data on the ACCESS.bus.

To transmit a byte in an interrupt or polling controlled operation, the software should:

1. Check that both the BER and NEGACK bits of the ACBST register are cleared, and that the SDAST bit of the ACBST register is set. If the STASTRE bit of the ACBCTL1 register is set, also check that the STASTR bit of the ACBST register is cleared (and clear it if required).
2. Write the data byte to be transmitted to the ACBSDA register.

When either the NEGACK or BER bit of the ACBST register is set, an interrupt is generated. When the slave responds with a negative acknowledge, the NEGACK bit of the ACBST register is set and the SDAST bit of the ACBST register remains cleared. In this case, if the INTEN bit of the ACBCTL1 register is set, an interrupt is issued.

8.0 ACCESS.bus Interface (ACB) (Continued)

Master Receive

After becoming the bus master, the device can start receiving data on the ACCESS.bus.

To receive a byte in an interrupt or polling operation, the software should:

1. Check that the SDAST bit of the ACBST register is set and that the BER bit is cleared. If the STASTRE bit of the ACBCTL1 register is set, also check that the STASTRE bit of the ACBST register is cleared (and clear it if required).
2. Set the ACK bit of the ACBCTL1 register to 1, if the next byte is the last byte that should be read. This causes a negative acknowledge to be sent.
3. Read the data byte from the ACBSDA register.

Before receiving the last byte of data, set the ACK bit of the ACBCTL1 register.

Master Stop

To end a transaction, set the STOP bit of the ACBCTL1 register before clearing the current stall flag (i.e., the SDAST, NEGACK or STASTR bit of the ACBST register). This causes the ACB to send a Stop Condition immediately, and to clear the STOP bit of the ACBCTL1 register. A Stop Condition may be issued only when the device is the active bus master (the MASTER bit of the ACBST register is set).

Master Bus Stall

The ACB can stall the ACCESS.bus between transfers while waiting for the host response. The ACCESS.bus is stalled by holding the SCL signal low after the acknowledge cycle. Note that this is interpreted as the beginning of the following bus operation. The user must make sure that the next operation is prepared before the flag that causes the bus stall is cleared.

The flags that can cause a bus stall in master mode are:

- Negative acknowledge after sending a byte (NEGACK bit of the ACBST register =1).
- SDAST bit of the ACBST register =1.
- STASTRE bit of the ACBCTL1 register =1, after a successful start (STASTR bit of the ACBST register =1).

Repeated Start

A repeated start is performed when the device is already the bus master (MASTER bit of the ACBST register is set). In this case, the ACCESS.bus is stalled and the ACB awaits host handling due to the following states in the ACBST register: negative acknowledge (NEGACK bit =1), empty buffer (SDAST bit =1) and/or a stall after start (STASTR bit =1).

For a repeated start:

1. Set the START bit of the ACBCTL1 register =1.
2. In master receive mode, read the last data item from ACBSDA.
3. Follow the address send sequence, as described in "Sending the Address Byte".
4. If the ACB was awaiting handling (STASTR bit of the ACBST register =1), clear it only after writing the requested address and direction to ACBSDA.

Master Error Detection

The ACB detects illegal Start or Stop Conditions (i.e., a Start or Stop Condition within the data transfer, or the acknowledge cycle) and a conflict on the data lines of the ACCESS.bus. If an illegal condition is detected, BER is set, and master mode is exited (MASTER bit of the ACBST register is cleared).

Bus Idle Error Recovery

When a request to become the active bus master or a restart operation fails, the BER bit of the ACBST register is set to indicate the error. In some cases, both the device and the other device may identify the failure and leave the bus idle. In this case, the start sequence may be incomplete and the ACCESS.bus may remain deadlocked.

To recover from deadlock, use the following sequence:

1. Clear the BER and BB bits of the ACBCST register.
2. Wait for a timeout period to check that there is no other active master on the bus (the BB bit remains cleared).
3. Disable, and re-enable the ACB to put it in the non-addressed slave mode. This completely resets the functional block.

At this point, some of the slaves may not identify the bus error. To recover, the ACB becomes the bus master: it asserts a Start Condition, sends an address byte, then asserts a Stop Condition which synchronizes all the slaves.

8.0 ACCESS.bus Interface (ACB) (Continued)

8.2.8 Slave Mode

A slave device waits in idle mode for a master to initiate a bus transaction. Whenever the ACB is enabled and it is not acting as a master (the MASTER bit of the ACBST register is cleared), it acts as a slave device.

Once a Start Condition on the bus is detected, the device checks whether the address sent by the current master matches either:

- The ADDR bit value of the ACBADDR register, if the SAEN bit =1, or
- The general call address if the GCMEN bit of the ACBCTL1 register =1.

This match is checked even when the MASTER bit is set. If a bus conflict (on SDA or SCL) is detected, the BER bit of the ACBST register is set, the MASTER bit is cleared and the device continues to search the received message for a match.

If an address match or a global match is detected:

1. The device asserts its SDA pin during the acknowledge cycle.
2. The MATCH bit of the ACBCST register and the NMATCH bit of the ACBST register are set. If the XMIT bit of the ACBST register is set (slave transmit mode), the SDAST bit of the ACBST register is set to indicate that the buffer is empty.
3. If the INTEN bit of the ACBCTL1 register is set, an interrupt is generated the NMINTE bit is also set.
4. The software then reads the XMIT bit of the ACBST register to identify the direction requested by the master device. It clears the NMATCH bit of the ACBST Register so future byte transfers are identified as data bytes.

Slave Receive and Transmit

Slave receive and transmit are performed after a match is detected and the data transfer direction is identified. After a byte transfer, the ACB extends the acknowledge clock until the software reads or writes the ACBSDA register. The receive and transmit sequences are identical to those used in the master routine.

Slave Bus Stall

When operating as a slave, the device stalls the ACCESS.bus by extending the first clock cycle of a transaction in the following cases:

- SDAST bit of the ACBST register is set.
- NMATCH bit of the ACBST register and NMINTE bit of the ACBCTL1 register are set.

Slave Error Detection

The ACB detects illegal Start and Stop Conditions on the ACCESS.bus (i.e., a Start or Stop Condition within the data transfer or the acknowledge cycle). When this occurs, the BER bit is set and MATCH and GMATCH are cleared, setting the ACB as an unaddressed slave.

8.2.9 Configuration

SDA and SCL Signals

The SDA and SCL are open-drain signals. The device permits the user to define whether to enable or disable the internal pull-up of each of these signals.

ACB Clock Frequency

The ACB permits the user to set the clock frequency for the ACCESS.bus clock. The clock is set by the SCLFRQ field of the ACBCTL2 register, which determines the SCL clock period used by the device. This clock low period may be extended by stall periods initiated by the ACB or by another ACCESS.bus device. In case of a conflict with another bus master, a shorter clock high period may be forced by the other bus master until the conflict is resolved.

8.0 ACCESS.bus Interface (ACB) (Continued)

8.3 ACB REGISTERS

The following abbreviations are used to indicate the Register Type:

- R/W = Read/Write
- R = Read from a specific address returns the value of a specific register. Write to the same address is to a different register.
- W = Write
- RO = Read Only
- R/W1C = Read/Write 1 to Clear. Writing 1 to a bit clears it to 0. Writing 0 has no effect.

8.3.1 ACB Register Map

Offset	Mnemonic	Register Name	Type	Section
00h	ACBSDA	ACB Serial Data	R/W	8.3.2
01h	ACBST	ACB Status	Varies per bit	8.3.3
02h	ACBCST	ACB Control Status	Varies per bit	8.3.4
03h	ACBCTL1	ACB Control 1	R/W	8.3.5
04h	ACBADDR	ACB Own Address	R/W	8.3.6
05h	ACBCTL2	ACB Control 2	R/W	8.3.7

8.3.2 ACB Serial Data Register (ACBSDA)

This shift register is used to transmit and receive data. The most significant bit is transmitted (received) first, and the least significant bit is transmitted (received) last. Reading or writing to the ACBSDA register is allowed only when the SDAST bit of the ACBST register is set, or for repeated starts after setting the START bit. An attempt to access this register under other conditions may produce unpredictable results.

Location: Offset 00h

Type: R/W

Bit	7	6	5	4	3	2	1	0
Name	ACB Serial Data							
Reset								

8.0 ACCESS.bus Interface (ACB) (Continued)

8.3.3 ACB Status Register (ACBST)

This register maintains the current ACB status. On reset, and when the ACB is disabled, ACBST is cleared (00h).

Location: Offset 01h

Type: Varies per bit

Bit	7	6	5	4	3	2	1	0
Name	SLVSTP	SDAST	BER	NEGACK	STASTR	NMATCH	MASTER	XMIT
Reset	0	0	0	0	0	0	0	0

Bit	Type	Description
7	R/W1C	SLVSTP (Slave Stop) . Writing 0 to SLVSTP is ignored. 0: Writing 1 or ACB disabled 1: Stop Condition detected after a slave transfer in which MATCH or GCMATCH was set
6	RO	SDAST (SDA Status) 0: Reading from the ACBSDA register during a receive, or when writing to it during a transmit. When ACBCTL1.START is set, reading the ACBSDA register does not clear SDAST. This enables ACB to send a repeated start in master receive mode. 1: SDA Data register awaiting data (transmit - master or slave) or holds data that should be read (receive - master or slave).
5	R/W1C	BER (Bus Error) . Writing 0 to BER is ignored. 0: Writing 1 or ACB disabled 1: Start or Stop Condition detected during data transfer (i.e., Start or Stop Condition during the transfer of bits 2 through 8 and acknowledge cycle), or when an arbitration problem is detected.
4	R/W1C	NEGACK (Negative Acknowledge) . Writing 0 to NEGACK is ignored. 0: Writing 1 or ACB disabled 1: Transmission not acknowledged on the ninth clock (In this case, SDAST is not set)
3	R/W1C	STASTR (Stall After Start) . Writing 0 to STASTR is ignored. 0: Writing 1 or ACB disabled 1: Address sent successfully (i.e., a Start Condition sent without a bus error, or Negative Acknowledge), if ACBCTL1.STASTRE is set. This bit is ignored in slave mode. When STASTR is set, it stalls the ACCESS.bus by pulling down the SCL line, and suspends any further action on the bus (e.g., receive of first byte in master receive mode). In addition, if ACBCTL1.INTEN is set, it also causes the ACB to send an interrupt.
2	R/W1C	NMATCH (New Match) . Writing 0 to NMATCH is ignored. If ACBCTL1.INTEN is set, an interrupt is sent when this bit is set. 0: Software writes 1 to this bit 1: Address byte follows a Start Condition or a repeated start, causing a match or a global-call match.
1	RO	Master 0: Arbitration loss (BER is set) or recognition of a Stop Condition 1: Bus master request succeeded and master mode active
0	RO	XMIT (Transmit) . Direction bit. 0: Master/slave transmit mode not active 1: Master/slave transmit mode active

8.0 ACCESS.bus Interface (ACB) (Continued)

8.3.4 ACB Control Status Register (ACBCST)

This register configures and controls the ACB functional block. It maintains the current ACB status and controls several ACB functions. On reset and when the ACB is disabled, the non-reserved bits of ACBCST are cleared.

Location: Offset 02h

Type: Varies per bit

Bit	7	6	5	4	3	2	1	0
Name	Reserved		TGSCL	TSDA	GCMTCH	MATCH	BB	BUSY
Reset	0	0	0	X	0	0	0	0

Bit	Type	Description
7-6		Reserved
5	R/W	TGSCL (Toggle SCL Line) . Enables toggling the SCL line during error recovery. 0: Clock toggle completed 1: When the SDA line is low, writing 1 to this bit toggles the SCL line for one cycle. Writing 1 to TGSCL while SDA is high is ignored.
4	RO	TSDA (Test SDA Line) . This bit reads the current value of the SDA line. It can be used while recovering from an error condition in which the SDA line is constantly pulled low by an out-of-sync slave. Data written to this bit is ignored.
3	RO	GCMTCH (Global Call Match) 0: Start Condition or repeated Start and a Stop Condition (including illegal Start or Stop Condition) 1: In slave mode, ACBCTL1.GCMEN is set and the address byte (the first byte transferred after a Start Condition) is 00h.
2	RO	MATCH (Address Match) 0: Start Condition or repeated Start and a Stop Condition (including illegal Start or Stop Condition) 1: ACBADDR.SAEN is set and the first 7 bits of the address byte (the first byte transferred after a Start Condition) match the 7-bit address in the ACBADDR register.
1	R/W1C	BB (Bus Busy) 0: Writing 1, ACB disabled, or Stop Condition detected 1: Bus active (a low level on either SDA or SCL), or Start Condition
0	RO	Busy . This bit should always be written 0. This bit indicates the period between detecting a Start Condition and completing receipt of the address byte. After this, the ACB is either free or enters slave mode. 0: Completion of any state below or ACB disabled 1: ACB is in one of the following states: — Generating a Start Condition — Master mode (ACBST.MASTER is set) — Slave mode (ACBCST.MATCH or ACBCST.GCMTCH set).

8.0 ACCESS.bus Interface (ACB) (Continued)

8.3.5 ACB Control Register 1 (ACBCTL1)

Location: Offset 03h

Type: R/W

Bit	7	6	5	4	3	2	1	0
Name	STASTRE	NMINTE	GCMEN	ACK	Reserved	INTEN	STOP	START
Reset	0	0	0	0	0	0	0	0

Bit	Description
7	<p>STASTRE (Stall After Start Enable)</p> <p>0: When cleared, ACBST.STASTR can not be set. However, if ACBST.STASTR is set, clearing STASTRE will not clear ACBST.STASTR.</p> <p>1: Stall after start mechanism enabled, and ACB stalls the bus after the address byte</p>
6	<p>NMINTE (New Match Interrupt Enable)</p> <p>0: No interrupt issued on a new match</p> <p>1: Interrupt issued on a new match only if ACBCTL1.INTEN set</p>
5	<p>GCMEN (Global Call Match Enable)</p> <p>0: ACB not responding to global call</p> <p>1: Global call match enabled</p>
4	<p>Receive Acknowledge. This bit is ignored in transmit mode. When the device acts as a receiver (slave or master), this bit holds the stop transmitting instruction that is transmitted during the next acknowledge cycle.</p> <p>0: Cleared after acknowledge cycle</p> <p>1: Negative acknowledge issued on next received byte</p>
3	Reserved
2	<p>Interrupt Enable</p> <p>0: ACB interrupt disabled</p> <p>1: ACB interrupt enabled. An interrupt is generated in response to one of the following events:</p> <ul style="list-style-type: none"> — Detection of an address match (ACBST.NMATCH=1) and NMINTE=1 — Receipt of Bus Error (ACBST.BER=1) — Receipt of Negative Acknowledge after sending a byte (ACBST.NEGACK=1) — Acknowledge of each transaction (same as the hardware set of the ACBST.SDAST bit) — In master mode if ACBCTL1.STASTRE=1, after a successful start (ACBST.STASTR=1) — Detection of a Stop Condition while in slave mode (ACBST.SLVSTP=1).
1	<p>Stop</p> <p>0: Automatically cleared after STOP issued</p> <p>1: Setting this bit in master mode generates a Stop Condition to complete or abort current message transfer</p>
0	<p>Start. Set this bit only when in master mode or when requesting master mode.</p> <p>0: Cleared after Start Condition sent or Bus Error (ACBST.BER=1) detected</p> <p>1: Single or repeated Start Condition generated on the ACCESS.bus. If the device is not the active master of the bus (ACBST.MASTER=0), setting START generates a Start Condition when the ACCESS.bus becomes free (ACBCST.BB=0). An address transmission sequence should then be performed.</p> <p>If the device is the active master of the bus (ACBST.MASTER=1), setting START and then writing to the ACBSDA register generates a Start Condition. If a transmission is already in progress, a repeated Start Condition is generated. This condition can be used to switch the direction of the data flow between the master and the slave, or to choose another slave device without separating them with a Stop Condition.</p>

8.0 ACCESS.bus Interface (ACB) (Continued)

8.3.6 ACB Own Address Register (ACBADDR)

This is a byte-wide register that holds the ACB ACCESS.bus address. The reset value of this register is undefined.

Location: Offset 04h

Type: R/W

Bit	7	6	5	4	3	2	1	0
Name	SAEN		ADDR					
Reset								

Bit	Description
7	SAEN (Slave Address Enable) 0: ACB does not check for an address match with ADDR field 1: ADDR field holds a valid address and enables the match of ADDR to an incoming address byte
6-0	ADDR (Own Address). These bits hold the 7-bit device address. When in slave mode, the first 7 bits received after a Start Condition are compared with this field (first bit received is compared with bit 6, and the last bit with bit 0). If the address field matches the received data and SAEN (bit 7) is 1, a match is declared.

8.3.7 ACB Control Register 2 (ACBCTL2)

This register enables/disables the functional block and determines the ACB clock rate.

Location: Offset 05h

Type: R/W

Bit	7	6	5	4	3	2	1	0
Name	SCLFRQ							ENABLE
Reset	0	0	0	0	0	0	0	0

Bit	Description
7-1	SCLFRQ (SCL Frequency). This field defines the SCL period (low and high time) when the device serves as a bus master. The clock low and high times are defined as follows: $t_{SCLl} = t_{SCLh} = 2 * SCLFRQ * t_{CLK}$ where t_{CLK} is the module input clock cycle, as defined in the <i>Device Architecture and Configuration</i> chapter. SCLFRQ can be programmed to values in the range of 0001000_2 (8_{10}) through 1111111_2 (127_{10}). Using any other value has unpredictable results.
0	Enable 0: ACB disabled, ACBCTL1, ACBST and ACBCST cleared, and clocks halted 1: ACB enabled

8.0 ACCESS.bus Interface (ACB) (Continued)

8.4 ACB REGISTER BITMAP

Register		Bits							
Offset	Mnemonic	7	6	5	4	3	2	1	0
00h	ACBSDA	ACB Serial Data							
01h	ACBST	SLVSTP	SDAST	BER	NEGACK	STASTR	NMATCH	MASTER	XMIT
02h	ACBCST	Reserved		TGSCL	TSDA	GCMTCH	MATCH	BB	BUSY
03h	ACBCTL1	STASTRE	NMINTE	GCMEN	ACK	Reserved	INTEN	STOP	START
04h	ACBADDR	SAEN	ADDR						
05h	ACBCTL2	SCLFRQ							ENABLE

9.0 Game Port (GMP)

9.1 OVERVIEW

This chapter describes a generic Game Port. For the implementation used in this device, see the *Device Architecture and Configuration* chapter.

The Game Port monitors the interface of up to two game devices, and provides data that can be used to determine the exact momentary status of these game devices.

A game device is an instrument used for giving commands to a PC, usually to control a game executed on that PC. A Joystick is a commonly used game device. These commands are given by the game device in a passive manner, by indicating several status parameters that can be captured by the system via the Game Port.

The status of a game device includes the following parameters:

- Button status (pressed/released) of up to two buttons per game device
- Horizontal (X-axis) position indicated by the game device
- Vertical (Y-axis) position indicated by the game device.

Figure 27 shows the basic system configuration of the Game Port.

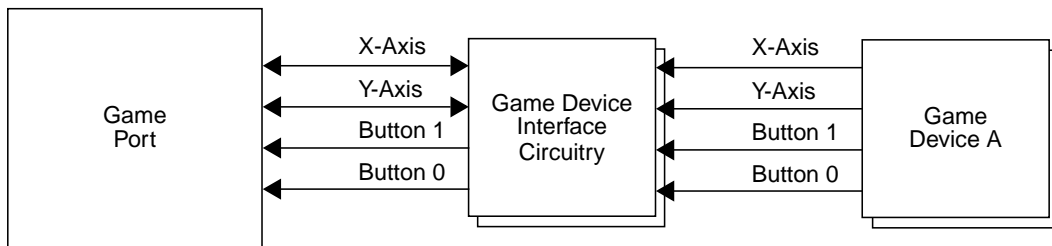

Figure 27. Game Port System Configuration

9.2 FUNCTIONAL DESCRIPTION

9.2.1 Game Device Axis Position Indication

A typical game device has the following interface pins:

- an X-axis position indicator
- a Y-axis position indicator
- one or two button status indicator(s).

The X and Y axis indicators are fed into the Game Port via pins JOYnX and JOYnY, respectively, where 'n' indicates the game device number. The status indicators of buttons 0 and 1 are fed into the Game Port via JOYnBTN0,1, respectively.

The X and Y axis position indication mechanism of each game device includes external components, as seen in Figure 28. Such a mechanism is implemented per game device axis line.

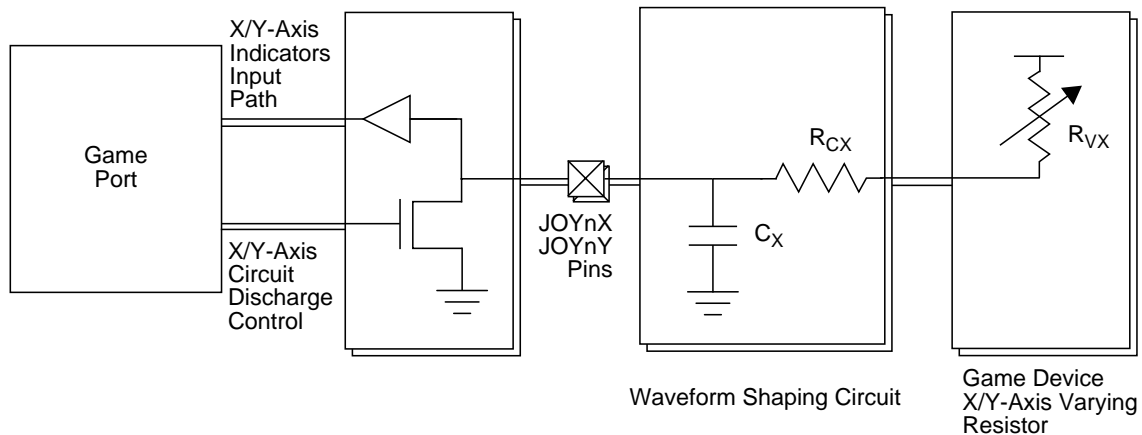

Figure 28. Game Device Axis Position Indication Mechanism

9.0 Game Port (GMP) (Continued)

The varying resistors R_{VX} and R_{VY} are usually implemented in the game device. Their resistance values are determined directly by the horizontal and vertical positions, respectively, indicated by the game device. The waveform shaping circuits are usually implemented outside the game device using constant resistors ($R_{CX/Y}$) and constant capacitors ($C_{X/Y}$). Together with $R_{VX/Y}$, these components implement two R-C structures, the varying parameters of which are used to determine the exact momentary position indicated by the game device.

When the Game Port is enabled and not in the midst of a game device position reading process, it drives the JOYnX,Y pins low. In this state, the capacitors $C_{X/Y}$ are completely discharged.

9.2.2 Capturing the Position

The process of capturing the position indicated by the game device is initiated by a command given to the Game Port to release the JOYnX,Y lines, thus allowing the capacitors $C_{X/Y}$ to be charged. This command is given by performing a write access to offset 1 from the Game Port base address, which is the offset of the Game Port Legacy Status Register (GMPLST, see Section 9.3.3). Once JOYnX,Y pins are released, $R_{CX/Y}$ and $R_{VX/Y}$ start charging $C_{X/Y}$, and the voltage level of the JOYnX,Y pins increases until it reaches V_{IH} . This process is described in Figure 29.

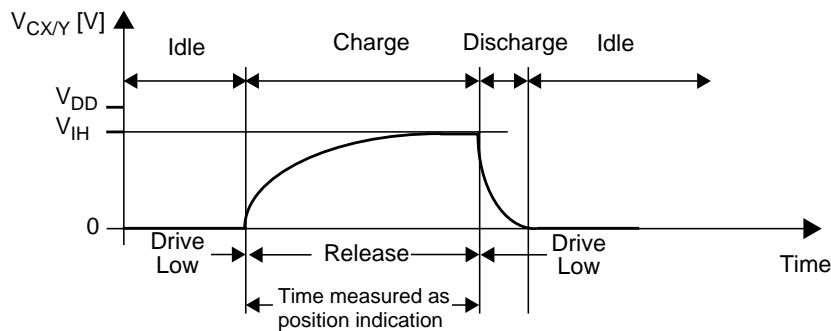

Figure 29. Position Reading Process Waveform (not drawn to scale)

The vertical and horizontal positions indicated by the game device are determined by measuring the time it takes for the voltage level on the JOYnX,Y pins to reach the level of logic 1. Since the charging time is determined by the resistance values of $R_{VX/Y}$, measuring this time actually indicates the resistance values of $R_{VX/Y}$, and therefore also reflects the position indicated by the game device.

Once an axis pin is sensed as logic 1, the axis circuit discharge control is activated in order to discharge $C_{X/Y}$. This causes the corresponding axis pin to be driven low for approximately 1.5 μsec . After that, this axis line is held low until another position reading process is initiated.

During the charge time and the 1.5 μsec discharge time which follows, the corresponding axis line does not respond to any reading process initiation. This prevents software from disturbing the position reading process and makes the position reading processes of all axis lines independent of each other.

9.0 Game Port (GMP) (Continued)

9.2.3 Button Status Indication

The button(s) status indication mechanism is described in Figure 30. Although this figure shows an active-low button ($R_{BU0} \gg R_{BD0}$), the polarity of the button can be either high or low, assuming that the Game Port software is aware of the button's polarity.

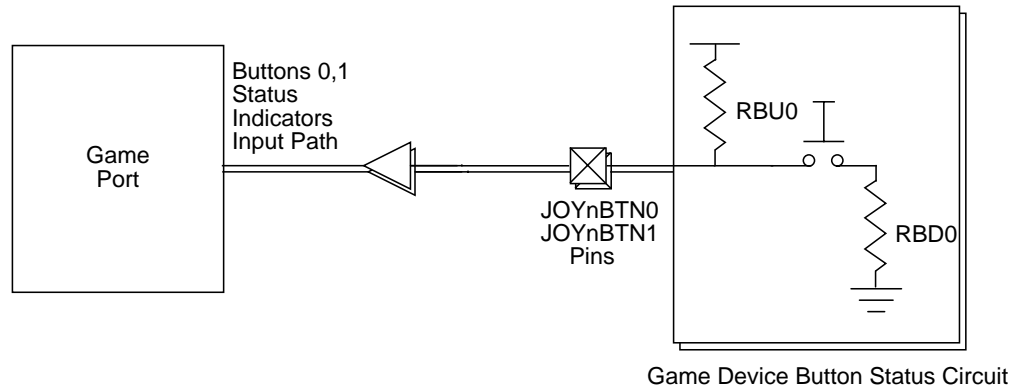

Figure 30. Game Device Button Status Indication Mechanism

A simple push-button mechanism is usually used to implement the game device buttons. The status of each button is sensed by the Game Port via the JOYnBTN0,1 pins as either high or low, and reflected by the GMPLST register. It is the responsibility of the software to determine the actual status of the buttons according to their polarity, which depends on the specific implementation of the system and the game device.

9.2.4 Operation Modes

The Game Port can be used to monitor the position and button status indicators in one of the following operation modes:

- Legacy mode
- Enhanced mode.

Legacy Mode

Legacy mode is enabled when bit 0 of the GMPCTL register is set to 0, which is its default state.

In this mode, the game device indicators are monitored by polling their momentary status via the Game Port Legacy Status register (GMPLST, see Section 9.3.3).

The process of reading the position status of the game device(s) is initiated by performing a write access to offset 1 in the Game Port address space. This write access causes the Game Port to release the JOYnX,Y pins. When a JOYnX,Y pin is released, the corresponding bit in the GMPLST register is set to 1. To capture the position indicated by the game device, the software must poll the GMPLST register and measure the time it takes for the JOYnX,Y to go high. This measurement should be performed by measuring the time during which an axis bit is 1.

Reading the status of the buttons of the game device is done by polling the GMPLST register and looking for changes in the bits reflecting the status of the JOYnBTN0,1 pins.

No debounce of the input signals is performed by the Game Port in Legacy mode. It is the responsibility of the software to implement such debounce, if necessary.

Enhanced Mode

Enhanced mode is enabled when bit 0 of the GMPCTL register is set to 1.

In Enhanced mode, the Game Port hardware monitors the status indicators of the game device(s), and provides processed data that can be easily used by software to determine the complete status of the game device.

The process of reading the position status of the game device(s) is initiated the same way it is done in Legacy mode. However, in Enhanced mode the Game Port hardware measures the $C_{X,Y}$ charging time using four 16-bit up-counters. Each one of the four axis status lines (two lines per game device) has a dedicated counter.

Once the Game Port releases the JOYnX,Y to go high, each one of the counters starts counting until its associated axis status line reaches the voltage level of logic 1.

9.0 Game Port (GMP) (Continued)

When a position counter of a game device stops counting, its associated Position Counter Ready bit in the GMPXST register is set. All the software has to do in this case is wait until the counters associated with the game device are ready, and then read their values. The least significant byte of a position counter should be read first. The full, 16-bit count value should be calculated as follows:

$$X/Y \text{ Position Count} = \text{GMPnX/YL} + (\text{GMPnX/YH} * 256)$$

where:

GMPnX/YL indicates the low byte of the position counter of device n (either X or Y axis)

GMPnY/HL indicates the high byte of the position counter of device n (either X or Y axis)

It is the responsibility of the software to calibrate itself according to the actual count values acquired when the game device was set to indicate its extreme horizontal and vertical positions.

If a position counter has reached the full count of FFFFh, it means that this counter has overflowed. Overflow means that the counter has reached its full count before the corresponding axis indicator has reached the level of logic 1. In such a case, the software must decide what to do.

The Game Port supports the following clock frequencies for operating the position counters:

- 1 MHz clock (default)
- 500 KHz clock.

The clock frequency for the position counter of each game device is configured via the GMPCTL register and should be set by the software to match the physical components of the external game device interface circuitry. Setting the desired position counter frequency should be done before initiating a position status reading process.

Reading the status of the buttons of the game device(s) is done the same way it is done in Legacy mode. In addition, an optional debouncer of 16 msec is implemented on each button status input. The debouncers are disabled by default and may be enabled by software via the GMPCTL register.

9.2.5 Operation Control

When the Game Port is operated in Legacy mode, it can only be operated by polling (see Section 9.2.4, *Legacy Mode*).

When the Game Port is operated in Enhanced mode, both kinds of status reading operations (position and button) can be performed using polling or interrupt controlled operation.

If polling controlled operation is preferred, the software should poll either the GMPLST register for the direct status of the buttons as in Legacy mode, or the GMPXST register which provides indications regarding button events detected by hardware. The GMPXST register should also be polled for the status of the position counters. When the status is ready, the counter values can be read. These values reflect the positions indicated by the game device.

If interrupt controlled operation is preferred, the software should first define the events on which an interrupt request is to be issued. This is done by writing the required values to the GMPEPOL (see Section 9.3.14) and GMPIEN (see Section 9.3.5) registers. The GMPEPOL register defines the events on which the buttons cause an interrupt request to be issued. These events are all edge-triggered. The GMPIEN register determines what events are physically routed to the interrupt request assigned to the Game Port. An independent interrupt enable bit is implemented in the GMPIEN register for each one of the four buttons and two position counters of the two supported game devices.

9.0 Game Port (GMP) (Continued)

9.3 GAME PORT REGISTERS

The following abbreviations are used to indicate the Register Type:

- R/W = Read/Write
- R = Read from a specific address returns the value of a specific register. Write to the same address is to a different register.
- W = Write
- RO = Read Only
- R/W1C = Read/Write 1 to Clear. Writing 1 to a bit clears it to 0. Writing 0 has no effect.

9.3.1 Game Port Register Map

The following table lists the Game Port registers. for the Game Port register bitmap, see Section 9.4.

Offset	Mnemonic	Register Name	Type	Section
00h	GMPCTL	Game Port Control	R/W	9.3.2
01h	GMPPLST	Game Port Legacy Status	RO	9.3.3
02h	GMPXST	Game Port Extended Status	R/W1C	9.3.4
03h	GMPIEN	Game Port Interrupt Enable	R/W	9.3.5
04h	GMPAXL	Game Device A X Position Low Byte	RO	9.3.6
05h	GMPAXH	Game Device A X Position High Byte	RO	9.3.7
06h	GMPAYL	Game Device A Y Position Low Byte	RO	9.3.8
07h	GMPAYH	Game Device A Y Position High Byte	RO	9.3.9
08h	GMPBXL	Game Device B X Position Low Byte	RO	9.3.10
09h	GMPBXH	Game Device B X Position High Byte	RO	9.3.11
0Ah	GMPBYL	Game Device B Y Position Low Byte	RO	9.3.12
0Bh	GMPBYH	Game Device B Y Position High Byte	RO	9.3.13
0Ch	GMPEPOL	Game Port Event Polarity	R/W	9.3.14

9.0 Game Port (GMP) (Continued)

9.3.2 Game Port Control Register (GMPCTL)

This register affects the functionality of the Game Port only when operated in Enhanced mode (bit 0 of this register is set to 1). Bits 1,2 and 4-7 affect Game Port functionality, as described in the table below.

Location: Offset 00h

Type: R/W

Bit	7	6	5	4	3	2	1	0
Name	Device B Button 1 Debounce Enable	Device B Button 0 Debounce Enable	Device A Button 1 Debounce Enable	Device A Button 0 Debounce Enable	Reserved	Device B Pre-Scale Enable	Device A Pre-Scale Enable	GMP Enhanced Mode Enable
Reset	0	0	0	0	0	0	0	0
Required					0			

Bit	Description
7	Device B Button 1 Debounce Enable. When set to 1, enables a 16 ms input debouncer on Device B Button 1 status input. 0: Disabled (default) 1: Enabled
6	Device B Button 0 Debounce Enable. Same as bit 7, but for Device B Button 0. 0: Disabled (default) 1: Enabled
5	Device A Button 1 Debounce Enable. Same as bit 7, but for Device A Button 1. 0: Disabled (default) 1: Enabled
4	Device A Button 0 Debounce Enable. Same as bit 7, but for Device A Button 0. 0: Disabled (default) 1: Enabled
3	Reserved
2	Device B Pre-Scale Enable. This bit determines the clock frequency used by Device B position counters. 0: 1 MHz (default) 1: 500 KHz
1	Device A Pre-Scale Enable. This bit determines the clock frequency used by Device A position counters. 0: 1 MHz (default) 1: 500 KHz
0	GMP Enhanced Mode Enable 0: Disabled (default) 1: Enabled

9.0 Game Port (GMP) (Continued)

9.3.3 Game Port Legacy Status Register (GMPLST)

This register is functional in all Game Port operation modes. Reading this register returns the status and the state of Device A and B button and Axis pins, as defined in the table below. Writing to the offset of this register initiates a game device position reading process by forcing a low pulse to be driven on the axis pins in Legacy and Enhanced modes, and by initializing all position counters in Enhanced mode.

Location: Offset 01h

Type: RO

Bit	7	6	5	4	3	2	1	0
Name	Device B Button 1 Pin Status	Device B Button 0 Pin Status	Device A Button 1 Pin Status	Device A Button 0 Pin Status	Device B Y-Axis Pin Status	Device B X-Axis Pin Status	Device A Y-Axis Pin Status	Device A X-Axis Pin Status
Reset	X	X	X	X	X	X	X	X

Bit	Description
7	Device B Button 1 Pin Status. This bit directly reflects the status of Device B Button 1 input pin. 0: Low 1: High
6	Device B Button 0 Pin Status. This bit directly reflects the status of Device B Button 0 input pin. 0: Low 1: High
5	Device A Button 1 Pin Status. This bit directly reflects the status of Device A Button 1 input pin. 0: Low 1: High
4	Device A Button 0 Pin Status. This bit directly reflects the status of Device A Button 0 input pin. 0: Low 1: High
3	Device B Y-Axis Pin Status. This bit reflects the state of Device B Y-axis input pin. 0: JOYBY pin is released for charging 1: JOYBY pin is driven low
2	Device B X-Axis Pin Status. This bit reflects the state of Device B X-axis input pin. 0: JOYBX pin is released for charging 1: JOYBX pin is driven low
1	Device A Y-Axis Pin Status. This bit reflects the state of Device A Y-axis input pin. 0: JOYAY pin is released for charging 1: JOYAY pin is driven low
0	Device A X-Axis Pin Status. This bit reflects the status of Device A X-axis input pin. 0: JOYAX pin is released for charging 1: JOYAX pin is driven low

9.0 Game Port (GMP) (Continued)

9.3.4 Game Port Extended Status Register (GMPXST)

This register indicates which of the corresponding game device interface events have occurred. Writing 1 to a bit clears it. Reading a position counter clears the corresponding Counter Ready bit. Writing to a bit 0 has no effect.

This register is functional only in Enhanced mode.

Location: Offset 02h

Type: R/W1C

Bit	7	6	5	4	3	2	1	0
Name	Device B Button 1 Event Status	Device B Button 0 Event Status	Device A Button 1 Event Status	Device A Button 0 Event Status	Device B Y-Position Counter Ready	Device B X-Position Counter Ready	Device A Y-Position Counter Ready	Device A X-Position Counter Ready
Reset	0	0	0	0	0	0	0	0

Bit	Description
7	Device B Button 1 Event Status. When set to 1, it indicates that a Device B Button 1 event has occurred. The event itself is defined by the GMPEPOL register, see Section 9.3.14. 0: Event not active (default) 1: Event active
6	Device B Button 0 Event Status. When set to 1, it indicates that a Device B Button 0 event has occurred. The event itself is defined by the GMPEPOL register, see Section 9.3.14. 0: Event not active (default) 1: Event active
5	Device A Button 1 Event Status. When set to 1, it indicates that a Device A Button 1 event has occurred. The event itself is defined by the GMPEPOL register, see Section 9.3.14. 0: Event not active (default) 1: Event active
4	Device A Button 0 Event Status. When set to 1, it indicates that a Device A Button 0 event has occurred. The event itself is defined by the GMPEPOL register, see Section 9.3.14. 0: Event not active (default) 1: Event active
3	Device B Y-Position Counter Ready. When set to 1, it indicates that the value of the Y-position counter of Device B can now be read. 0: Event not active (default) 1: Event active
2	Device B X-Position Counter Ready. When set to 1, it indicates that value of the X-position counter of Device B can now be read. 0: Event not active (default) 1: Event active
1	Device A X-Position Counter Ready. When set to 1, it indicates that the value of the Y-position counter of Device A can now be read. 0: Event not active (default) 1: Event active
0	Device A X-Position Counter Ready. When set to 1, it indicates that the value of the X-position counter of Device A can now be read. 0: Event not active (default) 1: Event active

9.0 Game Port (GMP) (Continued)

9.3.5 Game Port Interrupt Enable Register (GMPIEN)

This register defines the conditions on which the Game Port asserts its interrupt request signal.

This register is functional only in Enhanced mode.

Location: Offset 03h

Type: R/W

Bit	7	6	5	4	3	2	1	0
Name	Device B Button 1 IRQ Enable	Device B Button 0 IRQ Enable	Device A Button 1 IRQ Enable	Device A Button 0 IRQ Enable	Reserved	Position IRQ Event Definition	Device B Position IRQ Enable	Device A Position IRQ Enable
Reset	0	0	0	0	0	0	0	0

Bit	Description
7	Device B Button 1 IRQ Enable. When set to 1, the Game Port issues an interrupt request in response to an event triggered by Button 1 of Device B. When set to 0, Button 1 of Device B cannot cause interrupt requests to be issued. 0: Disabled (default) 1: Enabled
6	Device B Button 0 IRQ Enable. Same as bit 7 of this register, but for Device B Button 0. 0: Disabled (default) 1: Enabled
5	Device A Button 1 IRQ Enable. Same as bit 7 of this register, but for Device A Button 1. 0: Disabled (default) 1: Enabled
4	Device A Button 0 IRQ Enable. Same as bit 7 of this register, but for Device A Button 0. 0: Disabled (default) 1: Enabled
3	Reserved
2	Position IRQ Event Definition Defines the event on which the position IRQ is asserted for both game devices. 0: Both X-Position Counter and Y-Position Counter are ready 1: Either X-Position Counter or Y-Position Counter is ready
1	Device B Position IRQ Enable. When set to 1, the Game Port issues an interrupt request when the position reading of Device B is completed and the position counters can be read. When set to 0, no interrupt request is issued in response to any change in the status of Device B position counters. 0: Disabled (default) 1: Enabled
0	Device A Position IRQ Enable. Same as bit 2 of this register, but for Device A. 0: Disabled (default) 1: Enabled

9.0 Game Port (GMP) (Continued)

9.3.6 Game Device A X-Axis Position Low Byte (GMPAXL)

Reading this register returns the value of the low byte of the X-axis position counter of game Device A. Before reading this register verify that bit 0 of GMPXST (Device A Position Counter Ready) is set to 1. Writing to the offset of this register is ignored.

This register is functional only in Enhanced mode.

Location: Offset 04h

Type: RO

Bit	7	6	5	4	3	2	1	0
Name	Device A X-Axis Position Counter Low Byte							
Reset	0	0	0	0	0	0	0	0

9.3.7 Game Device A X-Axis Position High Byte (GMPAXH)

Reading this register returns the value of the high byte of the X-axis position counter of game Device A. Read this register after reading the GMPAXL register, and verifying that bit 0 of GMPXST (Device A Position Counter Ready) is set to 1. Writing to the offset of this register is ignored.

This register is functional only in Enhanced mode.

Location: Offset 05h

Type: RO

Bit	7	6	5	4	3	2	1	0
Name	Device A X-Axis Position Counter High Byte							
Reset	0	0	0	0	0	0	0	0

9.3.8 Game Device A Y-Axis Position Low Byte (GMPAYL)

Reading this register returns the value of the low byte of the Y-axis position counter of game Device A. Before reading this register verify that bit 1 of GMPXST (Device A Position Counter Ready) is set to 1. Writing to the offset of this register is ignored.

This register is functional only in Enhanced mode.

Location: Offset 06h

Type: RO

Bit	7	6	5	4	3	2	1	0
Name	Device A Y-Axis Position Counter Low Byte							
Reset	0	0	0	0	0	0	0	0

9.3.9 Game Device A Y-Axis Position High Byte (GMPAYH)

Reading this register returns the value of the high byte of the Y-axis position counter of game Device A. Read this register after reading the GMPAYL register and verifying that bit 1 of GMPXST (Device A Position Counter Ready) is set to 1. Writing to the offset of this register is ignored.

This register is functional only in Enhanced mode.

Location: Offset 07h

Type: RO

Bit	7	6	5	4	3	2	1	0
Name	Device A Y-Axis Position Counter High Byte							
Reset	0	0	0	0	0	0	0	0

9.0 Game Port (GMP) (Continued)

9.3.10 Game Device B X-Axis Position Low Byte (GMPBXL)

Reading this register returns the value of the low byte of the X-axis position counter of game Device B. Before reading this register verify that bit 2 of GMPXST (Device B Position Counter Ready) is set to 1. Writing to the offset of this register is ignored.

This register is functional only in Enhanced mode.

Location: Offset 08h

Type: RO

Bit	7	6	5	4	3	2	1	0
Name	Device B X-Axis Position Counter Low Byte							
Reset	0	0	0	0	0	0	0	0

9.3.11 Game Device B X-Axis Position High Byte (GMPBXH)

Reading this register returns the value of the high byte of the X-axis position counter of game Device B. Before reading this register verify that bit 2 of GMPXST (Device B Position Counter Ready) is set to 1. Writing to the offset of this register is ignored.

This register is functional only in Enhanced mode.

Location: Offset 09h

Type: RO

Bit	7	6	5	4	3	2	1	0
Name	Device B X-Axis Position Counter High Byte							
Reset	0	0	0	0	0	0	0	0

9.3.12 Game Device B Y-Axis Position Low Byte (GMPBYL)

Reading this register returns the value of the low byte of the Y-axis position counter of game Device B. Before reading this register verify that bit 3 of GMPXST (Device B Position Counter Ready) is set to 1. Writing to the offset of this register is ignored.

This register is functional only in Enhanced mode.

Location:Offset 0Ah

Type: RO

Bit	7	6	5	4	3	2	1	0
Name	Device B Y-Axis Position Counter Low Byte							
Reset	0	0	0	0	0	0	0	0

9.3.13 Game Device B Y-Axis Position High Byte (GMPBYH)

Reading this register returns the value of the high byte of the Y-axis position counter of game Device B. Before reading this register verify that bit 3 of GMPXST (Device B Position Counter Ready) is set to 1. Writing to the offset of this register is ignored.

This register is functional only in Enhanced mode.

Location:Offset 0Bh

Type: RO

Bit	7	6	5	4	3	2	1	0
Name	Device B Y-Axis Position Counter High Byte							
Reset	0	0	0	0	0	0	0	0

9.0 Game Port (GMP) (Continued)

9.3.14 Game Port Event Polarity Register (GMPEPOL)

This register defines the polarity of button events on which the Game Port issues an interrupt request.

This register is functional only in Enhanced mode.

Location: Offset 0Ch

Type: R/W

Bit	7	6	5	4	3	2	1	0
Name	Device B Button 1 Event Polarity		Device B Button 0 Event Polarity		Device A Button 1 Event Polarity		Device A Button 0 Event Polarity	
Reset	0	0	0	0	0	0	0	0

Bit	Description										
7-6	<p>Device B Button 1 Event Polarity. This bit defines the event polarity on which Device B Button 1 issues an interrupt request.</p> <p>Bits</p> <table border="0"> <tr> <td>7 6</td> <td>Number</td> </tr> <tr> <td>0 0</td> <td>None (default)</td> </tr> <tr> <td>0 1</td> <td>Rising edge</td> </tr> <tr> <td>1 0</td> <td>Falling edge</td> </tr> <tr> <td>1 1</td> <td>Rising and falling edge</td> </tr> </table>	7 6	Number	0 0	None (default)	0 1	Rising edge	1 0	Falling edge	1 1	Rising and falling edge
7 6	Number										
0 0	None (default)										
0 1	Rising edge										
1 0	Falling edge										
1 1	Rising and falling edge										
5-4	<p>Device B Button 0 Event Polarity. Same as bits 7-6 of this register, but for Device B Button 0.</p> <p>Bits</p> <table border="0"> <tr> <td>5 4</td> <td>Number</td> </tr> <tr> <td>0 0</td> <td>None (default)</td> </tr> <tr> <td>0 1</td> <td>Rising edge</td> </tr> <tr> <td>1 0</td> <td>Falling edge</td> </tr> <tr> <td>1 1</td> <td>Rising and falling edge</td> </tr> </table>	5 4	Number	0 0	None (default)	0 1	Rising edge	1 0	Falling edge	1 1	Rising and falling edge
5 4	Number										
0 0	None (default)										
0 1	Rising edge										
1 0	Falling edge										
1 1	Rising and falling edge										
3-2	<p>Device A Button 1 Event Polarity. Same as bits 7-6 of this register, but for Device A Button 1.</p> <p>Bits</p> <table border="0"> <tr> <td>3 2</td> <td>Number</td> </tr> <tr> <td>0 0</td> <td>None (default)</td> </tr> <tr> <td>0 1</td> <td>Rising edge</td> </tr> <tr> <td>1 0</td> <td>Falling edge</td> </tr> <tr> <td>1 1</td> <td>Rising and falling edge</td> </tr> </table>	3 2	Number	0 0	None (default)	0 1	Rising edge	1 0	Falling edge	1 1	Rising and falling edge
3 2	Number										
0 0	None (default)										
0 1	Rising edge										
1 0	Falling edge										
1 1	Rising and falling edge										
1-0	<p>Device A Button 0 Event Polarity. Same as bits 7-6 of this register, but for Device A Button 0.</p> <p>Bits</p> <table border="0"> <tr> <td>1 0</td> <td>Number</td> </tr> <tr> <td>0 0</td> <td>None (default)</td> </tr> <tr> <td>0 1</td> <td>Rising edge</td> </tr> <tr> <td>1 0</td> <td>Falling edge</td> </tr> <tr> <td>1 1</td> <td>Rising and falling edge</td> </tr> </table>	1 0	Number	0 0	None (default)	0 1	Rising edge	1 0	Falling edge	1 1	Rising and falling edge
1 0	Number										
0 0	None (default)										
0 1	Rising edge										
1 0	Falling edge										
1 1	Rising and falling edge										

9.0 Game Port (GMP) (Continued)

9.4 GAME PORT BITMAP

Register		Bits							
Offset	Mnemonic	7	6	5	4	3	2	1	0
00h	GMPCTL	Device B Button 1 Debounce Enable	Device B Button 0 Debounce Enable	Device A Button 1 Debounce Enable	Device A Button 0 Debounce Enable	Reserved	Device B Pre-Scale Enable	Device A Pre-Scale Enable	GMP Enhanced Mode Enable
01h	GMPNST	Device B Button 1 Pin Status	Device B Button 0 Pin Status	Device A Button 1 Pin Status	Device A Button 0 Pin Status	Device B Y-Axis Pin Status	Device B X-Axis Pin Status	Device A Y-Axis Pin Status	Device A X-Axis Pin Status
02h	GMPXST	Device B Button 1 Event Status	Device B Button 0 Event Status	Device A Button 1 Event Status	Device A Button 0 Event Status	Device B Y-Position Counter Ready	Device B X-Position Counter Ready	Device A Y-Position Counter Ready	Device A X-Position Counter Ready
03h	GMPIEN	Device B Button 1 IRQ Enable	Device B Button 0 IRQ Enable	Device A Button 1 IRQ Enable	Device A Button 0 IRQ Enable	Reserved	Position IRQ Event Definition	Device B Position IRQ Enable	Device A Position IRQ Enable
04h	GMPAXL	Device A X-Axis Position Counter Low Byte							
05h	GMPAXH	Device A X-Axis Position Counter High Byte							
06h	GMPAYL	Device A Y-Axis Position Counter Low Byte							
07h	GMPAYH	Device A Y-Axis Position Counter High Byte							
08h	GMPBXL	Device B X-Axis Position Counter Low Byte							
09h	GMPBXH	Device B X-Axis Position Counter High Byte							
0Ah	GMPBYL	Device B Y-Axis Position Counter Low Byte							
0Bh	GMPBYH	Device B Y-Axis Position Counter High Byte							
0Ch	GMPEPOL	Device B Button 1 Event Polarity		Device B Button 0 Event Polarity		Device A Button 1 Event Polarity		Device A Button 0 Event Polarity	

10.0 Musical Instrument Digital Interface (MIDI) Port

10.1 OVERVIEW

This chapter describes a generic MIDI Port. For the implementation used in this device, see the *Device Architecture and Configuration* chapter.

The MIDI Port is an asynchronous receiver/transmitter that uses a two-wire, bi-directional, relatively slow communication channel to transmit and receive data bytes to or from MIDI-compliant devices, according to a predefined communication protocol. The MIDI Port is compatible with MPU-401 UART mode.

The MIDI was originally defined to establish a standard interface between computers and digital musical instruments such as synthesizers, and has become the de facto standard for this purpose. However, the MIDI is also commonly used for other purposes, such as communicating with advanced game devices.

The MIDI Port serves as a communication pipe between software and a MIDI device. The software and the MIDI device must interpret the data they exchange, and act accordingly.

The MIDI Port supports the following two feature types:

- Legacy (MPU-401)
- Enhanced.

Legacy. These include all features supported by MPU-401 UART mode. They can all be operated via the Legacy I/O address space of 2 bytes, traditionally allocated for the MIDI Port.

Enhanced. These features extend the capabilities of the MIDI Port. They can only be operated if the MIDI is allocated with an address space of at least 3 bytes.

The basic system configuration of the MIDI Port consists of the port itself, a single pull-up resistor for the MDRX pin, and a MIDI compliant device. This system configuration is shown in Figure 31. The purpose of the pull-up resistor is to make sure that the MIDI Port senses an inactive (high) MIDI receive signal in the absence of a MIDI device.

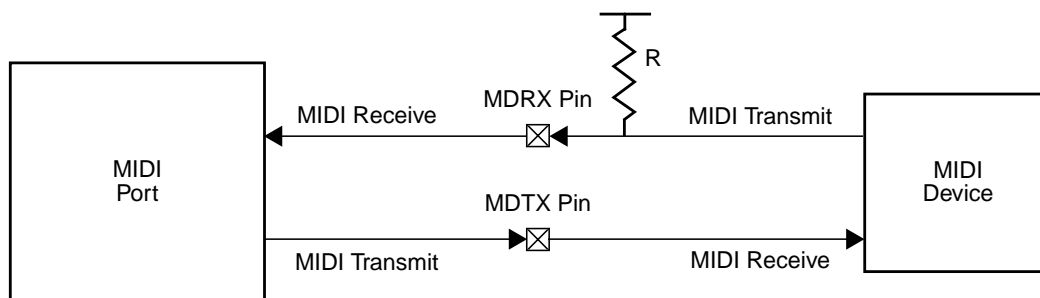

Figure 31. MIDI System Configuration

10.2 FUNCTIONAL DESCRIPTION

The MIDI Port consists of five major functional blocks:

- Internal Bus Interface Unit
- Port Control and Status Registers
- Data Buffers and FIFOs
- MIDI Communication Engine
- MIDI Signals Routing Control Logic.

See Figure 32 for a block diagram of the MIDI Port.

10.0 Musical Instrument Digital Interface (MIDI) Port (Continued)

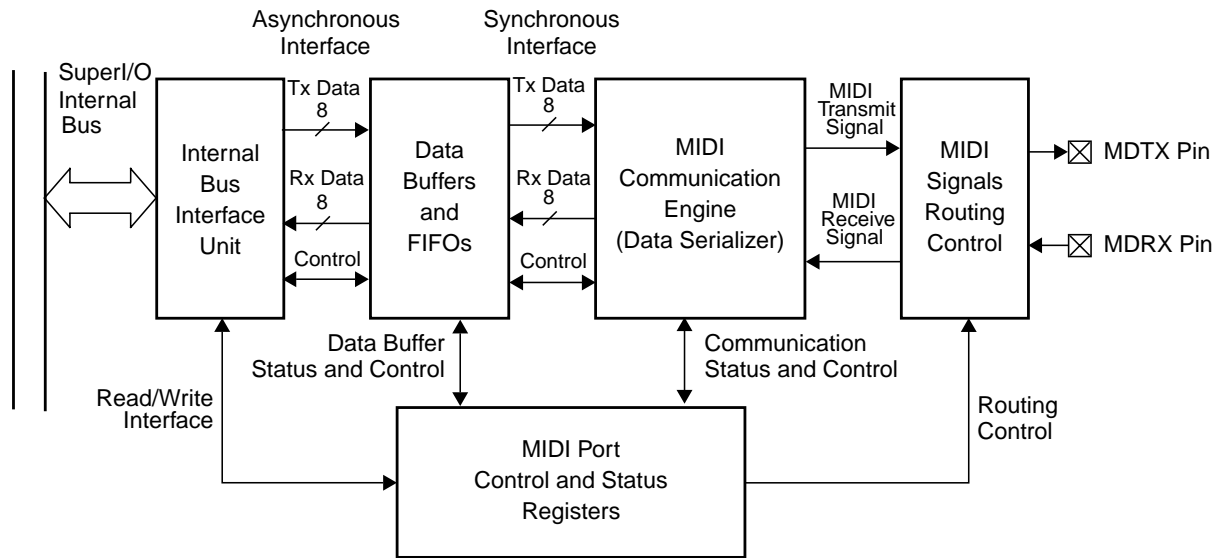

Figure 32. MIDI Port Block Diagram

10.2.1 Internal Bus Interface Unit

The Internal Bus Interface Unit handles all read and write transactions between the host and the registers of the MIDI Port. It also controls the MIDI Port interrupt request logic (see Section 10.2.8).

10.2.2 Port Control and Status Registers

A Control register (MCNTL, see Section 10.3.6) and a Status register (MSTAT, see Section 10.3.4) allow the user to control the operation of the MIDI, and provide status information regarding its various functional units. A Command register (MCOM, see Section 10.3.5) allows the user to control the operation mode of the MIDI Port by serving as a port via which the host can issue commands to the MIDI. A MIDI Port command is defined as a write access to the MIDI Command register. The meaning of each command is determined by the data byte written during this write access.

10.2.3 Data Buffers and FIFOs

The Data Buffers and FIFOs function as a mechanism for synchronizing between the Internal Bus Interface Unit and the MIDI Communication Engine. This synchronization allows each of these units to handle its own tasks without having to pause to send/receive data to/from the other unit. Synchronization also bridges the gap in the data transfer rate between these two units. Data transfer rate matching is done when the FIFOs of the MIDI Port are enabled. It allows the MIDI Port to interface a bus at a relatively high data transfer rate, while maintaining communication with a MIDI device over a communication channel that supports a relatively low data transfer rate.

10.2.4 MIDI Communication Engine

The MIDI Communication Engine handles the serializing of outgoing data and the de-serializing of incoming data transferred between the MIDI Port and the MIDI device. During transmit (serial data transfer from the MIDI Port to the MIDI device), the Communication Engine receives data bytes from the output data buffer or FIFO, serializes them into a stream of data bits, and transmits them as a sequence of high and low pulses over the MDTX pin according to the MIDI communication protocol. During receive (serial data transfer from the MIDI device to the MIDI Port), the Communication Engine receives a sequence of high and low pulses via the MDRX pin, converts them into a stream of data bits and de-serializes them into data bytes that it sends to the input data buffer or FIFO.

Both transmit and receive are performed at a fixed serial data rate of 31.25 Kbits per second. The serial data format is also fixed, and consists of 1 Start bit, 8 Data bits and 1 Stop bit. See the waveform illustrating a MIDI byte transfer in Figure 33.

10.0 Musical Instrument Digital Interface (MIDI) Port (Continued)

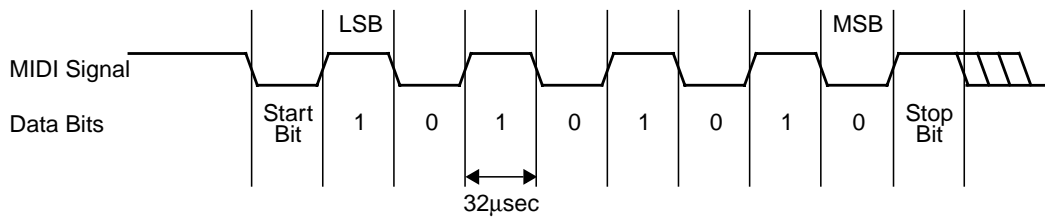

Figure 33. MIDI Byte Transfer Waveform

10.2.5 MIDI Signals Routing Control Logic

The MIDI Signals Routing Control Logic controls the various routing options available for the MIDI transmit and receive signals. It is controlled by the MIDI Control register (MCNTL, see Section 10.3.6). These routing options are not part of the Legacy definition of the MIDI Port.

10.2.6 Operation Modes

The MIDI Port can be operated in one of the following modes:

- Pass-Thru (Non-UART) Mode (default)
- UART Mode.

Pass-Thru (Non-UART) Mode

After a hardware reset, the MIDI Port is in Pass-Thru mode.

In this mode, transmission is disabled by default, and all writes to the MIDI Data Out register (MDO, see Section 10.3.3) are ignored. Transmission in this mode may be enabled by setting bit 4 of the MIDI Control register (MCNTL, see Section 10.3.6).

Receive in Pass-Thru mode is enabled, and a 16-byte Receive FIFO is available. Reading the MIDI Data In register (MDI, see Section 10.3.2) in this mode returns the oldest data stored in the Receive FIFO. If serial data is received while the Receive FIFO is full with data that has not yet been read, the last received data is lost, thus maintaining the data that was previously stored in the Receive Buffer.

When in Pass-Thru mode, the MIDI Port responds to commands issued by the host, as follows:

- 3Fh puts the MIDI Port in UART mode. Also, in response to this command, the MIDI Port puts an acknowledge byte of FEh in the Receive Buffer.
- A0h-A7h or ABh causes the MIDI Port to put an acknowledge byte of FEh followed by a data byte of 00h in the Receive Buffer.
- ACh causes the MIDI Port to put an acknowledge byte of FEh, followed by a data byte of 15h, in the Receive Buffer.
- ADh causes the MIDI Port to put an acknowledge byte of FEh, followed by a data byte of 01h, in the Receive Buffer.
- AFh causes the MIDI Port to put an acknowledge byte of FEh, followed by a data byte of 64h, in the Receive Buffer.
- FFh resets the MIDI Port to its initial state, including all the bits of the MSTAT register. In response, the MIDI Port puts an acknowledge of FEh in the Receive Buffer. This command is usually referred to as the MIDI Reset Command.
- The MIDI Port responds to all other commands by putting an acknowledge byte of FEh in the Receive Buffer.

Putting the acknowledge byte of FEh is equivalent to receiving a data byte. Therefore, once an acknowledge byte is put in the Receive Buffer, it causes the Receive Buffer Empty status flag (see Section 10.2.7) to be cleared, which may also cause a MIDI Port interrupt request to be issued.

When the Receive FIFO is disabled, switching from Pass-Thru mode to UART mode causes data stored in the Receive Buffer to be lost. After switching to UART mode, the MIDI Port is blocked for receive until the acknowledge byte is read from the Receive Buffer.

If a command is issued to the MIDI Port while the MIDI Communication Engine is in the middle of a byte transfer (the Start bit has been transmitted or received), the execution of the command and the response are postponed until the ongoing byte transfer is completed.

After each MIDI Port operation in Pass-Thru mode, the MIDI Status register (MSTAT, see Section 10.3.4) is updated accordingly.

10.0 Musical Instrument Digital Interface (MIDI) Port (Continued)

UART Mode

Entering UART mode is done by software, by giving the MIDI Port command of 3Fh. Once in UART mode, both transmit and receive are enabled. In addition, the two 16-byte Receive and Transmit FIFOs are automatically enabled.

In UART mode, data written to the MDO register is placed in the Transmit FIFO, from which it is taken by the MIDI Communication Engine and transmitted via the MDTX pin to the MIDI device. Likewise, whenever the Transmit FIFO is not empty, the next byte is taken out by the Communication Engine and transmitted via the MDTX pin to the MIDI device.

Whenever serial data is received by the Communication Engine via the MDRX pin, it is de-serialized and put in the Receive FIFO. Reading the MDI register returns the next byte in the Receive FIFO. The MDI register should not be read while the Receive FIFO is empty. If serial data is received while the Receive FIFO is full, this data is lost and not stored in the Receive FIFO, thus keeping the data that was previously stored in the Receive FIFO.

When in UART mode, the MIDI Port responds to commands given by the host as follows:

- A command of FFh returns the MIDI Port to Pass-Thru mode, and resets it to its initial state.
- All other commands, issued while the MIDI Port is in UART mode, are ignored.

When switching from UART mode to Pass-Thru mode, any data previously stored in the Receive FIFO is lost, unless the FIFO is enabled for Pass-Thru mode.

As in Pass-Thru mode, if a command is issued to the MIDI Port while the MIDI Communication Engine is in the middle of a byte transfer, the execution of the command and the response are postponed until the ongoing byte transfer is completed.

The MIDI commands supported by the MIDI Port and their respective responses are listed in Table 49.

After each MIDI Port operation in UART mode, the MSTAT register is updated accordingly.

Table 49. MIDI Commands Supported by the MIDI Port

Command	MIDI Port Response	
	Pass-Thru Mode	UART Mode
3Fh	Enter UART mode FEh (Acknowledge)	Ignored
A0h-A7h, ABh	FEh (Acknowledge) 00h	Ignored
ACh	FEh (Acknowledge) 15h	Ignored
ADh	FEh (Acknowledge) 01h	Ignored
AFh	FEh (Acknowledge) 64h	Ignored
FFh	MIDI Port Reset FEh (Acknowledge)	Enter Pass-Thru Mode MIDI Port Reset
Others	FEh (Acknowledge)	Ignored

10.2.7 MIDI Port Status Flags

The status of the various functional units of the MIDI Port is reflected by the MSTAT register. This register is functional in both Pass-Thru and UART modes. Some of the status indications provided by the MSTAT register are not included in the Legacy definition of the MIDI Port. These indications can be ignored, if not required by the software.

The following status flags are included in the Legacy definition of the MIDI Port:

- Receive Buffer Empty
- Transmit Buffer Full

The Receive Buffer Empty flag is reflected by bit 7 of the MSTAT register. The Transmit Buffer Full flag is reflected by bit 6 of the MSTAT register. When operating in UART mode, these bits reflect the status of the Receive and Transmit FIFOs.

The Receive Buffer Empty status flag is cleared to 0 also when an acknowledge byte is put by the MIDI Port itself following a MIDI command.

10.0 Musical Instrument Digital Interface (MIDI) Port (Continued)

The values of these bits are set by the MIDI Port hardware and are not affected by reading the MSTAT register.

The following status indications are provided by the MIDI Port, although they are not included in the Legacy definition of the MIDI Port:

- Receive FIFO Full
- Transmit FIFO Empty
- Receive Overrun Error
- MIDI Port Operation Mode

The Receive FIFO Full and Transmit FIFO Empty status flags are reflected by MSTAT register bits 5 and 2, respectively. These bits are updated only when the MIDI Port operates in UART mode or when in Pass-Thru mode with the Receive FIFO enabled. Otherwise, these bits are constantly cleared. The values of these bits are set by the MIDI Port hardware and are not affected by reading the MSTAT register.

The Receive Overrun Error flag indicates that serial data has been received by the MIDI Communication Engine while the Receive Buffer of FIFO was full. This flag is reflected by bit 3 of the MSTAT register. It is updated in both Pass-Thru and UART modes. When a Receive Overrun Event occurs, the data in the Receive Buffer/FIFO is kept and all incoming data is lost. Incoming data will keep getting lost until there is room in the Receive Buffer/FIFO to accept it. The Receive Overrun Error status flag is cleared when the MSTAT register is read.

The MIDI Port Operation Mode flag indicates whether the MIDI Port currently operates in Pass-Thru or UART mode. This status flag is reflected by bit 4 of the MSTAT register. It can be used by software to keep track of the currently selected MIDI Port operation mode.

10.2.8 MIDI Port Interrupts

The MIDI Port supports interrupt assertion in both Pass-Thru and UART modes, in response to one of the following events, or both:

- Receive Data Ready
- Transmit Buffer Empty

The Receive Data Ready event refers to the case in which there is data to be read in the Receive Buffer/FIFO. An interrupt request is asserted by the MIDI Port to indicate a Receive Data Ready event in one of the following cases:

- The MIDI Port is in Pass-Thru mode, and the Receive Buffer contains a data or acknowledge byte which has not been read yet. In this case, the interrupt request is deasserted once the Receive Buffer is read.
- The MIDI Port is in UART mode, and the Receive FIFO contains eight, or more, data bytes which have not been read yet, or it is in Pass-Thru mode with the Receive FIFO enabled. In this case, the interrupt request is deasserted once the Receive FIFO level drops below eight bytes.
- The MIDI Port is in UART mode, the Receive FIFO contains less than eight data bytes which have not been read yet, and no data was received by the Communication Engine, the MIDI Port is in Pass-Thru mode with the Receive FIFO enabled, or a read occurs from the Receive FIFO during a timeout period of approximately 1.28 msec (the time it takes to transfer 4 bytes over the MIDI communication channel). In this case, the interrupt request is deasserted when either new data is received by the Communication Engine, or data is read from the Receive FIFO.

The Transmit Buffer Empty event refers to the case in which the Transmit Buffer/FIFO of the MIDI Port can still accept data to transmit. An interrupt request is asserted by the MIDI Port to indicate a Transmit Buffer Empty event in one of the following cases:

- The MIDI Port is in Pass-Thru mode, and the Transmit Buffer is empty. In this case, the interrupt request is deasserted once a byte is written to the Transmit Buffer.
- The MIDI Port is in UART mode, and the Transmit FIFO is empty. In this case, the interrupt request is deasserted once the Transmit FIFO is filled with at least 3 bytes.

After hardware reset, interrupts are asserted by the MIDI Port only in response to a Receive Data Ready event. Interrupt assertion in response to Transmit Buffer Empty events can be enabled by setting writing 1 to bit 1 of the MCNTL register. Interrupt assertion in response to Receive Data Ready events can be disabled by writing 0 to bit 3 of the MCNTL register.

10.0 Musical Instrument Digital Interface (MIDI) Port (Continued)

10.2.9 Enhanced MIDI Port Features

The MIDI Port supports the following modes/operations, which are not part of the Legacy definition of the MIDI Port:

- Transmit in Pass-Thru
- Loopback mode
- MIDI Thru
- MDTX pin masking

Transmit in Pass-Thru. When the MIDI Port is operated in Pass-Thru mode, transmit is disabled by default. To enable it, write 1 to bit 4 of the MCNTL register.

Loopback Mode. The MIDI serial data transmit signal is routed internally to the MIDI serial data receive signal. This causes all the data transmitted by the MIDI Port to also be received. Loopback mode can be used as a mode for testing the MIDI Port or its software. To enable it, write 1 to bit 7 of the MCNTL register.

MIDI Thru. The MIDI serial data receive signal is routed internally to the MIDI serial data transmit signal. This causes any incoming stream of pulses received via the MDRX pin to be driven immediately on the MDTX pin. This feature allows the MIDI Port to be connected as a link in a chain of several MIDI devices. In parallel to routing the MIDI receive signal to the MIDI transmit signals, the incoming serial data is also received by the MIDI Port itself. To enable it, write 1 to bit 6 of the MCNTL register.

MDTX Pin Masking. MDTX pin masking forces this pin to remain at a high level. This causes all transmit processes to occur without physically driving the serial data via the MDTX pin. Writing 1 to bit 2 of the MCNTL register enables MDTX pin masking.

The above three features are handled by the MIDI Signals Routing Control Logic, which is illustrated in Figure 34..

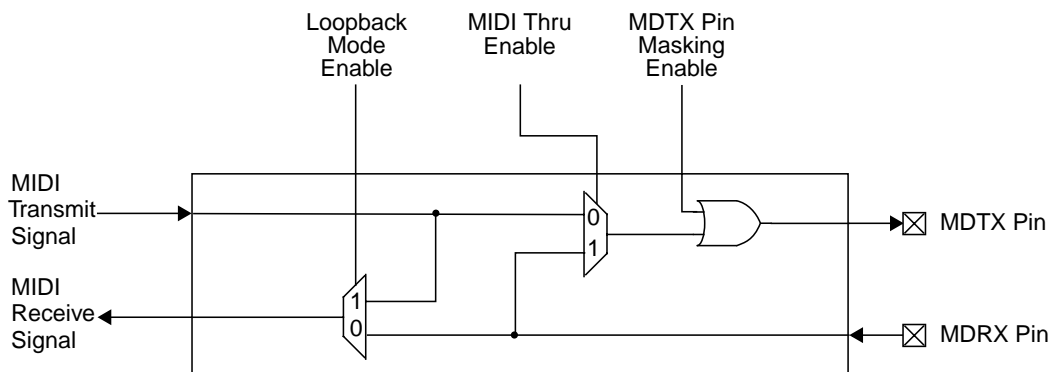

Figure 34. MIDI Signals Routing Control Logic

10.0 Musical Instrument Digital Interface (MIDI) Port (Continued)

10.3 MIDI PORT REGISTERS

The following abbreviations are used to indicate the Register Type:

- R/W = Read/Write
- R = Read from a specific address returns the value of a specific register. Write to the same address is to a different register.
- W = Write
- RO = Read Only
- R/W1C = Read/Write 1 to Clear. Writing 1 to a bit clears it to 0. Writing 0 has no effect.

10.3.1 MIDI Port Register Map

The following table lists the MIDI Port registers. For the MIDI Port register bitmap, see Section 10.4.

Offset	Mnemonic	Register Name	Type	Section
00h	MDI	MIDI Data In	R	10.3.2
00h	MDO	MIDI Data Out	W	10.3.3
01h	MSTAT	MIDI Status	R	10.3.4
01h	MCOM	MIDI Command	W	10.3.5
02h	MCNTL	MIDI Control	W/R	10.3.6

10.3.2 MIDI Data In Register (MDI)

This read register is used for reading data received by the MIDI Port, and status information returned by the MIDI Port in response to a previously issued command. When the FIFOs of the MIDI Port are enabled, reading from this offset returns the next byte taken out of the Receive FIFO.

Location: Offset 00h

Type: R

Bit	7	6	5	4	3	2	1	0
Name	Data In							
Reset	X	X	X	X	X	X	X	X

10.3.3 MIDI Data Out Register (MDO)

This write register is used for writing data to be transmitted by the MIDI Port. When the FIFOs of the MIDI Port are enabled, writing to this offset puts the data byte into the Transmit FIFO.

Location: Offset 00h

Type: W

Bit	7	6	5	4	3	2	1	0
Name	Data Out							
Reset	X	X	X	X	X	X	X	X

10.0 Musical Instrument Digital Interface (MIDI) Port (Continued)

10.3.4 MIDI Status Register (MSTAT)

This read register provides status information regarding the functional blocks of the MIDI Port.

Location: Offset 01h

Type: R

Bit	7	6	5	4	3	2	1	0
Name	Rx Buffer Empty	Tx Buffer Full	Rx FIFO Full	MIDI Port Operation Mode	Rx Overrun Error	Tx FIFO Not Empty	Reserved	
Reset	1	0	0	0	0	0	0	0

Bit	Description
7	Rx Buffer Empty. When set to 1, it indicates that the Receive Buffer in Pass-Thru mode, or the FIFO in UART mode, is empty. When set to 0, it indicates that the Receive Buffer or FIFO contain data that can be read via the MDI register. 0: Not empty 1: Empty (default)
6	Tx Buffer Full. When set to 1, it indicates that the Transmit Buffer or FIFO cannot accept any more data. When set to 0, it indicates that the Transmit Buffer or FIFO can accept more data written to the MDO register. 0: Not full (default) 1: Full
5	Rx FIFO Full. When set to 1, it indicates that the Receive FIFO cannot accept any more received data bytes. When set to 0, it indicates that the Receive FIFO can accept more received data bytes. This bit is forced to 0 when the FIFOs are disabled. 0: Not full or disabled (default) 1: Full
4	MIDI Port Operation Mode. When set to 1, it indicates that the MIDI Port is currently operating in UART mode. When set to 0, it indicates that the MIDI Port is currently operating in Pass-Thru (non-UART) mode. 0: Pass-Thru mode (default) 1: UART mode
3	Rx Overrun Error. This bit is cleared to 0 when the MSTAT register is read. An overrun error is defined as the state in which one or more data bytes have been received by the MIDI Port while the Receive Buffer, or FIFO, was full. 0: No overrun error (default) 1: Overrun error
2	Tx FIFO Not Empty. This bit is forced to 0 when the FIFOs are disabled. 0: Empty or disabled (default) 1: Not empty
1-0	Reserved

10.3.5 MIDI Command Register (MCOM)

This write register is a port via which commands are issued by the host to the MIDI Port.

Location: Offset 01h

Type: W

Bit	7	6	5	4	3	2	1	0
Name	Command Byte							
Reset	X	X	X	X	X	X	X	X

10.0 Musical Instrument Digital Interface (MIDI) Port (Continued)

10.3.6 MIDI Control Register (MCNTL)

This register controls enhanced MIDI functions.

Location: Offset 02h

Type: R/W

Bit	7	6	5	4	3	2	1	0
Name	Loopback Mode Enable	MIDI Thru Enable	Reserved	Pass-Thru Transmit Enable	Rx Data Ready Interrupt Enable	MDTX Pin Masking Enable	Tx Buffer Empty Interrupt Enable	Rx FIFO Enable for Pass-Thru Mode
Reset	0	0	0	0	1	0	0	1
Required			0					

Bit	Description
7	Loopback Mode Enable. When enabled, the MIDI receive signal is internally connected to the MIDI transmit signal. 0: Disabled (default) 1: Enabled
6	MIDI Thru Enable. When enabled, the MDRX pin is internally connected to the MDTX pin, which then reflects the MIDI receive signal. When disabled, the MDTX pin is driven with data coming from the MIDI Port transmit engine. 0: Disabled (default) 1: Enabled
5	Reserved
4	Pass-Thru Transmit Enable. When enabled, data is transmitted in Pass-Thru (non-UART) mode. 0: Disabled (default) 1: Enabled
3	Rx Data Ready Interrupt Enable. When enabled, an interrupt request is asserted in response to a Receive Data Ready event. 0: Disabled 1: Enabled (default)
2	MDTX Pin Masking Enable. When enabled, the MDTX pin is constantly driven high by the MIDI Port. When disabled, MDTX serves as the MIDI Port transmit line. 0: Disabled (default) 1: Enabled
1	Tx Buffer Empty Interrupt Enable. When enabled, an interrupt request is asserted in response to a Transmit Buffer Empty event. 0: Disabled (default) 1: Enabled
0	Rx FIFO Enable for Pass-Thru Mode. When this bit is set to 1, the Receive FIFO is enabled in Pass-Thru mode. This bit is ignored in UART mode. 0: Disabled 1: Enabled (default)

10.0 Musical Instrument Digital Interface (MIDI) Port (Continued)

10.4 MIDI PORT BITMAP

Register		Bits							
Offset	Mnemonic	7	6	5	4	3	2	1	0
00h	MDI	Data In							
00h	MDO	Data Out							
01h	MSTAT	Rx Buffer Empty	Tx Buffer Full	Rx Buffer Full	MIDI Port Operation Mode	Rx Overrun Error	Tx FIFO Empty	Reserved	
01h	MCOM	Command Byte							
02h	MCNTL	Loopback Mode Enable	MIDI Thru Enable	Reserved	Pass-Thru Transmit Enable	Rx Data Ready Interrupt Enable	MDTX Pin Masking Enable	Tx Buffer Empty Interrupt Enable	Rx FIFO Enable for Pass-Thru Mode

11.0 Voltage Level Monitor (VLM)

11.1 OVERVIEW

The Voltage Level Monitor (VLM) is an A/D converter that monitors various voltages in the system, reports their values to system monitoring software and can set an alarm when any of these voltages is outside a specified range. The VLM conforms to LDCM and DMI requirements for system monitoring.

The VLM can sense up to 14 voltage values. Seven sources are external and can be applied per system requirements. Four values are internal, used for V_{SB} , V_{DD} , V_{BAT} , and AV_{DD} . V_{SB} , V_{DD} , and AV_{DD} are internally divided by 2 to allow detection of voltage both over and under the specified range. TS1, TS2 and TS3 inputs are used for temperature measurement using a thermistor.

The host can query the various voltage readout values and configure the VLM to generate an \overline{ALARM} signal when the voltage is outside a specified range (below V_{iLOW} or above V_{iHIGH} , where i is the channel number). The \overline{ALARM} can generate an interrupt internally and/or output to a pin of the device.

11.2 FUNCTIONAL DESCRIPTION

The VLM incorporates an 8-bit A/D converter, and a set of control, configuration and status registers and digital circuitry that controls its operation. Figure 35 illustrates the structure of the VLM module.

The VLM measures the various input voltages periodically, as defined by the conversion rate setting (see Section 11.5.9). At the beginning of each period, a measurement trigger is issued, which starts a burst of conversion operations. The burst includes scanning all enabled channels, starting from channel 0.

To guarantee the stability of the signal at the input of the A/D converter, a delay is added between the end of each conversion and the beginning of the next. The delay between samples should be adjusted according to the resistance and capacitance of the input source. See Section 11.7.1 for how to calculate the sampling delay and Section 11.5.9 for the associated programming model.

The voltage readout is an unsigned integer between 0 and 255. Section 11.2.1 describes how the readout is converted to a voltage value.

The VLM is designed to preserve indication of failures by disabling the conversion whenever the $\overline{SLPS3}$ input becomes active (i.e., V_{DD} is expected to drop) and whenever an error is detected. The conversion and register updates resume only after power is restored and normal system operation resumes. To prevent loss of error condition flagging, the conversions for voltage measurement channels (0 through 10 only) that are out of range are stopped until the \overline{ALARM} status is cleared. Whenever $\overline{SLPS3}$ is not available in the system, the $\overline{SLPS3}$ input should be tied to 1 and the software should disable the measurements before the power fails, or ignore and clear any pending error flags after power is restored.

11.0 Voltage Level Monitor (VLM) (Continued)

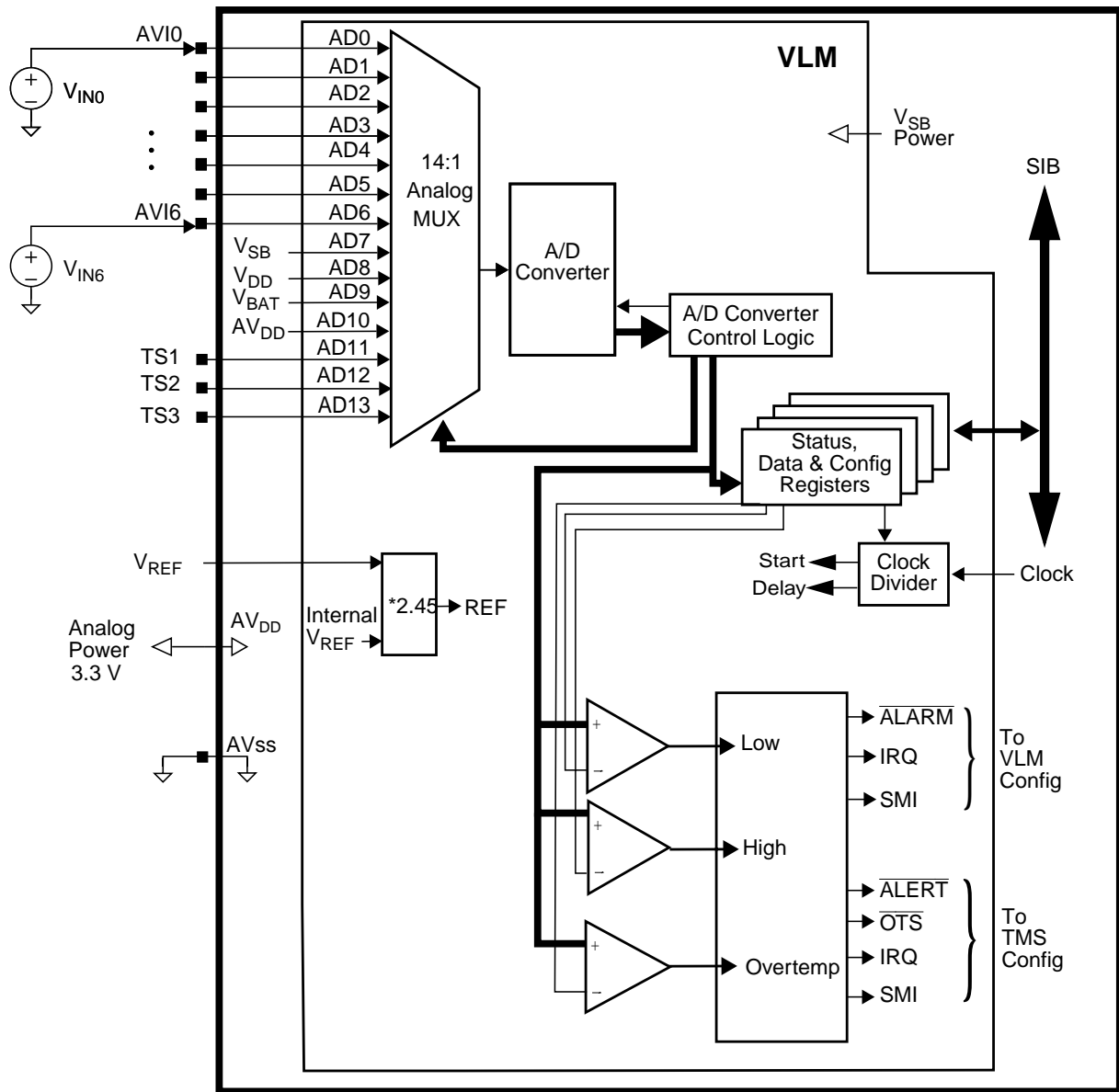

Figure 35. VLM Functional Diagram

11.2.1 Voltage Measurement, Channels 0 through 10

Voltage is measured relative to $2.45 \cdot V_{REF}$. (V_{REF} is the voltage of the V_{REF} input, or the internal reference voltage.) The results are output to the Read Channel Voltage (RDCHV) register associated with the channel. The voltage measured is:

$$V_i = 2.45 \cdot V_{REF} \cdot RDCHV_i / 256$$

V_{SB} , V_{DD} and AV_{DD} are internally divided by two. Therefore, the readouts are half their actual values. When external dividers are used to scale input voltage to within the dynamic range of the A/D Converter, appropriate scale factors should be taken into account.

V_{HIGH} and V_{LOW} Limits, \overline{ALARM} Output, IRQ and \overline{SMI}

The voltage reading is compared to two limits: V_{HIGH} and V_{LOW} . If the voltage reading is outside any of these limits, the respective status bit (Channel High Limit Exceeded or Channel Low Limit Exceeded) in the VCHCFST register is set. The status bit stays active until it is cleared by the software. An \overline{ALARM} status bit in the VEVSTS0 or VEVSTS1 register is set when the Channel High Limit Exceeded or the Channel Low Limit Exceeded bit for the respective channel is set.

11.0 Voltage Level Monitor (VLM) (Continued)

The $\overline{\text{ALARM}}$ output is used to indicate to the system that a voltage outside the high/low limits was detected. The $\overline{\text{ALARM}}$ output Enable bit in the VCHCFST register, enables the $\overline{\text{ALARM}}$ output to be active when the “Channel High Limit Exceeded” or the “Channel Low Limit Exceeded” status bit in the VCHCFST register is set.

The $\overline{\text{SMI}}$ output generates an interrupt if any enabled $\overline{\text{SMI}}$ event occurs. Each bit in the VEVSTS0/1 register has a corresponding $\overline{\text{SMI}}$ Enable bit in the VEVSMI0/1 register. When any status bit and its corresponding $\overline{\text{SMI}}$ Enable bit are set the $\overline{\text{SMI}}$ output is active.

The IRQ output generates an interrupt if any enabled IRQ event occurs. Each bit in the VEVSTS0/1 register has a corresponding IRQ Enable bit in the VEVIQ0/1 register. When any status bit and its corresponding IRQ Enable bit are set the IRQ output is active.

Alarm Response Read Sequence

When the VLM activates the $\overline{\text{ALARM}}$ output, the host should respond by reading the VEVSTS0 and VEVSTS1 registers. It should then access the register of each of the channels whose bit is set in the VEVSTS0 and VEVSTS1 registers and clear these bits by writing 1 to each of them.

11.2.2 Thermistor-Based Temperature Measurement, Channels 11 to 13

The VLM module can measure environmental temperature by using thermistors. This feature is supported over channels 11 to 13. The temperature measurement under this scheme is based on a voltage divider between AV_{DD} and AV_{SS} where one of the two resistors is a thermistor. See Figure 36.

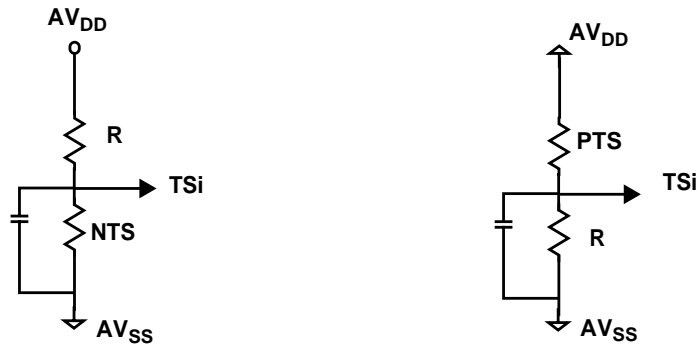

Figure 36. Measuring Temperature using Thermistors

The translation of voltage to temperature is determined by the parameters of the thermistor in use. The values in the registers with the results and limits are defined by the result of the voltage measurement. For the channels that support temperature measurement, standard temperature monitoring functions are provided: low and high temperature $\overline{\text{ALERT}}$, and overtemperature shutdown.

11.2.3 V_{OS} , V_{HIGH} and V_{LOW} Limits, $\overline{\text{OTS}}$ and $\overline{\text{ALERT}}$ Output, IRQ and $\overline{\text{SMI}}$

The voltage reading is compared to three limits: V_{OS} , V_{HIGH} and V_{LOW} . If the voltage reading is outside any of these limits, the respective status bit (Channel Overtemperature Limit Exceeded, Channel High Limit Exceeded or the Channel Low Limit Exceeded) in the VCHCFST register is set. The status bit will stay active until it is cleared by the software. An ALERT status bit in the VEVSTS0/1 register is set when the Channel High Limit Exceeded, the Channel Low Limit Exceeded or the Overtemperature Event bit for the respective channel is set.

The $\overline{\text{OTS}}$ output is used to indicate to the system that the overtemperature limit has been exceeded. The $\overline{\text{OTS}}$ Output Enable bit in the VCHCFST register, enables the $\overline{\text{OTS}}$ output to be active when the OTS status of the channel is active.

The $\overline{\text{ALERT}}$ output is used to indicate to the system that the current temperature is outside the high/low limits. The $\overline{\text{ALERT}}$ output Enable bit in the VCHCFST register, enables the $\overline{\text{ALERT}}$ output to be active when the “Channel High Limit Exceeded” or the “Channel Low Limit Exceeded” status bit in the VCHCFST register is set. [This signal is not connected in the 365 and 366.]

The $\overline{\text{SMI}}$ output generates an interrupt if any enabled $\overline{\text{SMI}}$ event occurs. Each bit in the VEVSTS1 register has a corresponding $\overline{\text{SMI}}$ Enable bit in the VEVSMI1 register. When any status bit and its corresponding $\overline{\text{SMI}}$ Enable bit are set the $\overline{\text{SMI}}$ output is active.

The IRQ output generates an interrupt if any enabled IRQ event occurs. Each bit in the VEVSTS1 register has a corresponding IRQ Enable bit in the VEVIQ1 register. When any status bit and its corresponding IRQ Enable bit are set the IRQ output is active.

11.0 Voltage Level Monitor (VLM) (Continued)

ALERT Response Read Sequence

When the VLM activates its **ALERT** output, the host should respond by reading the VEVSTS0 and VEVSTS1 registers. It should then access the register of each of the channels that has its respective bit set and clear the HIGHV and LOWV status bits by writing 1 to each of them.

11.2.4 Power-On Reset Default States

VLM power-on default conditions are:

- All registers are loaded with their default values.
- The **ALARM** output, IRQ, and **SMI** are disabled.

11.2.5 Standby Mode

Standby mode is enabled by setting the Standby Mode Enable bit in the VLMCFG register. Standby mode reduces power supply current by disabling new measurements, but register values are retained and the registers can be accessed by software (as usual).

11.3 ANALOG SUPPLY CONNECTION

11.3.1 Recommendations

Power is supplied to the analog parts of the A/D Converter through two dedicated analog power pins: AV_{DD} and AV_{SS}. This ensures effective isolation of the analog parts from noise caused by the digital parts. The digital parts of the VLM are supplied via V_{SB}. To obtain the best performance, bear in mind the following recommendations (see also details in Figure 37).

Ground Connection. The analog ground pin, AV_{SS}, should be connected at only one point to the digital ground pins. At this point, the following ground connections should also be made:

- The decoupling capacitors of the analog supply AV_{DD} pin
- The reference voltage V_{REF} pin
- The four digital supply V_{SB} pins
- The ground reference of the input signals to the A/D Converter.

Low impedance ground layers also improve noise isolation.

Power Connection. The analog supply pin, AV_{DD}, should be connected to a low noise power supply, 3.3V. It is recommended to supply the AV_{DD} pin through an external LC or RC filter. An example of an RC filter [R₁ and (C₂+C₃)] is shown in Figure 37.

Decoupling Capacitors. The following decoupling capacitors should be used:

- Digital V_{SB}: Place one capacitor of 0.1 μF on each V_{SB} pin, as close as possible to the pin (4 x C₄). Also, place one 10-47 μF tantalum capacitor (C₅) on the common net, as close as possible to the chip.
- Analog AV_{DD}: Place a 0.1 μF capacitor and a 10-47 μF tantalum capacitor on the AV_{DD} pins (C₃ and C₂), as close as possible to the pin.
- V_{REF}: Place a low leakage, non-polarized, 0.47 μF capacitor (C₁) as close as possible to the V_{REF} pin.

11.0 Voltage Level Monitor (VLM) (Continued)

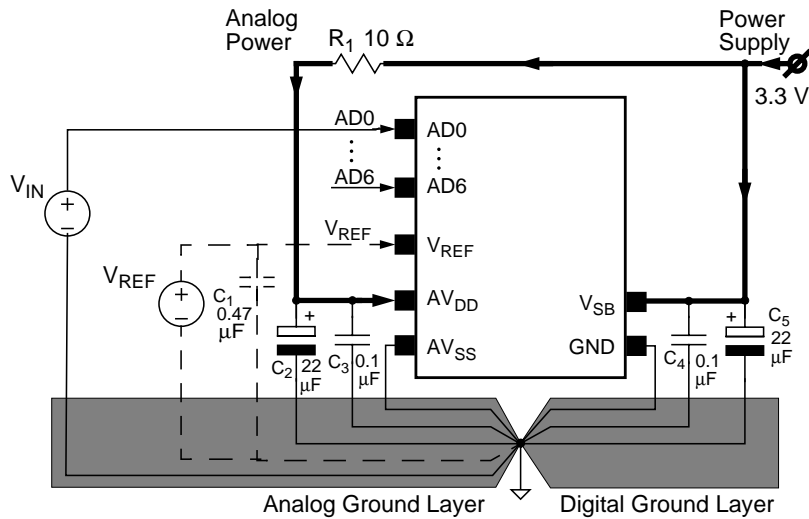

Figure 37. Analog Power Supply

11.3.2 Reference Voltage

Analog input voltage is measured relative to $2.45 \cdot V_{REF}$. V_{REF} may be either internal or external. When an internal V_{REF} is used, a capacitor should be connected between the V_{REF} pin and AV_{SS} . The V_{REF} default setting is for external. This default prevents contention between the internal and external V_{REF} .

Note that the V_{REF} setting is common to both the VLM and the TMS modules. If either of these modules is configured to use internal reference voltage, the internal reference voltage is used by both modules.

11.4 REGISTER BANK OVERVIEW

The VLM uses register banks to enable host access to its registers. The VLM has 10 common registers, in addition to 5 registers which are located in each of the 13 banks. The common registers include configuration and status information common to all the channels. Each of the banks is associated with one channel and holds its readout, configuration and status information. All registers use the same 16-byte address space to indicate offsets 00h through 0Fh. The active bank must be selected by the software.

The VLM Bank Selection (VLMBS) register, common to all banks, selects the active banks. See Figure 38. The default bank selection after system reset is 0.

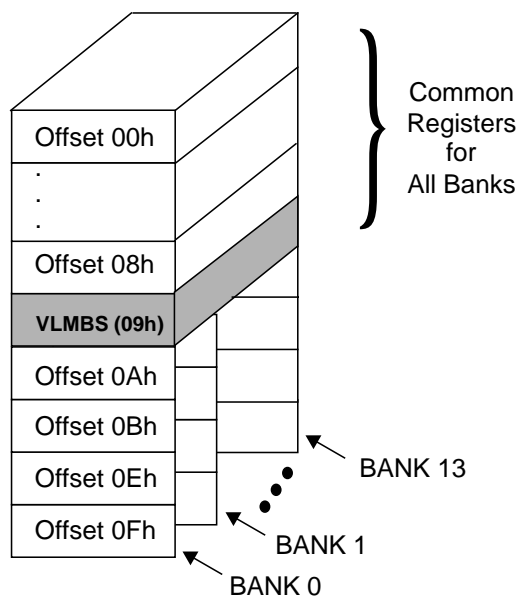

Figure 38. Register Bank Architecture

11.0 Voltage Level Monitor (VLM) (Continued)

11.5 VLM REGISTERS

The register maps in this chapter use the following abbreviations for Type:

- R/W = Read/Write
- R = Read from a specific address returns the value of a specific register. Write to the same address is to a different register.
- W = Write
- RO = Read Only
- R/W1C = Read/Write 1 to Clear. Writing 1 to a bit clears it to 0. Writing 0 has no effect.

11.5.1 VLM Register Map

Table 50. VLM Control and Status Register Map

Offset	Mnemonic	Register Name	Type	Section
00h	VEVSTS0	Voltage Event Status 0	RO	11.5.2
01h	VEVSTS1	Voltage Event Status 1	RO	11.5.3
02h	VEVSMI0	Voltage Event to \overline{SMI} 0	R/W	11.5.4
03h	VEVSMI1	Voltage Event to \overline{SMI} 1	R/W	11.5.5
04h	VEVIRQ0	Voltage Event to IRQ 0	R/W	11.5.6
05h	VEVIRQ1	Voltage Event to IRQ 1	R/W	11.5.7
06h	VID	Voltage ID	Varies per bit	11.5.8
07h	VCNVR	Voltage Conversion Rate	R/W	11.5.9
08h	VLMCFG	VLM Configuration	R/W	11.5.10
09h	VLMBS	VLM Bank Select	R/W	11.5.11

Table 51. VLM Channel Register Map (One per Channel)

Offset	Mnemonic	Register Name	Type	Section
0Ah	VCHCFST	Voltage Channel Configuration and Status	Varies per bit	11.5.12
0Bh	RDCHV	Read Channel Voltage	RO	11.5.13
0Ch	CHVH	Channel Voltage High Limit	R/W	11.5.14
0Dh	CHVL	Channel Voltage Low Limit	R/W	11.5.15
0Eh	OTSL	Overtemperature Shutdown Limit	R/W	11.5.16
0Fh	Reserved			

11.0 Voltage Level Monitor (VLM) (Continued)

11.5.2 Voltage Event Status Register 0 (VEVSTS0)

This register indicates which of the corresponding eight VLM events has occurred.

Location: Offset 00h

Type: RO

Bit	7	6	5	4	3	2	1	0
Name	VSB ALARM Event Status	AVI6 ALARM Event Status	AVI5 ALARM Event Status	AVI4 ALARM Event Status	AVI3 ALARM Event Status	AVI2 ALARM Event Status	AVI1 ALARM Event Status	AVI0 ALARM Event Status
Reset	0	0	0	0	0	0	0	0

Bit	Description
7	VSB ALARM Event Status. This channel measures the internal V_{SB} power, using $V_{SB}/2$. 0: Voltage level within limits (default) 1: High or low limit exceeded
6-0	Analog Voltage Inputs 6-0 ALARM Event Status 0: Voltage level within limits (default) 1: High or low limit exceeded

11.5.3 Voltage Event Status Register 1 (VEVSTS1)

This register indicates which of the corresponding VLM events has occurred.

Location: Offset 01h

Type: RO

Bit	7	6	5	4	3	2	1	0
Name	Reserved		TMS3 ALERT or $\overline{\text{OTS}}$ Event Status	TMS2 ALERT or $\overline{\text{OTS}}$ Event Status	TMS1 ALERT or $\overline{\text{OTS}}$ Event Status	AV_{DD} ALARM Event Status	VBAT ALARM Event Status	VDD ALARM Event Status
Reset	0	0	0	0	0	0	0	0

Bit	Description
7-6	Reserved
5	TMS3 ALERT or $\overline{\text{OTS}}$ Event Status 0: Voltage level within limits (default) 1: OTS, high or low limit exceeded
4	TMS2 ALERT or $\overline{\text{OTS}}$ Event Status 0: Voltage level within limits (default) 1: OTS, High or low limit exceeded
3	TMS1 ALERT or $\overline{\text{OTS}}$ Event Status 0: Voltage level within limits (default) 1: OTS, High or low limit exceeded

11.0 Voltage Level Monitor (VLM) (Continued)

Bit	Description
2	AV_{DD} ALARM Event Status. This channel measures the internal AV _{DD} power, using AV _{DD} /2. 0: Voltage level within limits (default) 1: High or low limit exceeded
1	VBAT ALARM Event Status. This channel measures the V _{BAT} power input. 0: Voltage level within limits (default) 1: High or low limit exceeded
0	VDD ALARM Event Status. This channel measures the internal V _{DD} power, using V _{DD} /2. 0: Voltage level within limits (default) 1: High or low limit exceeded

11.5.4 Voltage Event to $\overline{\text{SMI}}$ Register 0 (VEVSMI0)

This register is one of two registers that controls event routing to $\overline{\text{SMI}}$.

Location: Offset 02h

Type: R/W

Bit	7	6	5	4	3	2	1	0
Name	VSB Event to SMI Enable	AVI6 Event to SMI Enable	AVI5 Event to SMI Enable	AVI4 Event to SMI Enable	AVI3 Event to SMI Enable	AVI2 Event to SMI Enable	AVI1 Event to SMI Enable	AVI0 Event to SMI Enable
Reset	0	0	0	0	0	0	0	0

Bit	Description
7	VSB Event to $\overline{\text{SMI}}$ Enable 0: Disabled (default) 1: Enabled
6-0	AVI6-0 Event to $\overline{\text{SMI}}$ Enable 0: Disabled (default) 1: Enabled

11.0 Voltage Level Monitor (VLM) (Continued)

11.5.5 Voltage Event to $\overline{\text{SMI}}$ Register 1 (VEVSMI1)

This register is one of two registers that controls event routing to $\overline{\text{SMI}}$.

Location: Offset 03h

Type: RW

Bit	7	6	5	4	3	2	1	0
Name	Reserved		TMS3 Event to $\overline{\text{SMI}}$ Enable	TMS2 Event to $\overline{\text{SMI}}$ Enable	TMS1 Event to $\overline{\text{SMI}}$ Enable	AV _{DD} Event to SMI Enable	VBAT Event to $\overline{\text{SMI}}$ Enable	VDD Event to $\overline{\text{SMI}}$ Enable
Reset	0	0	0	0	0	0	0	0

Bit	Description
7-6	Reserved
5	TMS3 Event to $\overline{\text{SMI}}$ Enable 0: Disabled (default) 1: Enabled
4	TMS2 Event to $\overline{\text{SMI}}$ Enable 0: Disabled (default) 1: Enabled
3	TMS1 Event to $\overline{\text{SMI}}$ Enable 0: Disabled (default) 1: Enabled
2	AV_{DD} Event to $\overline{\text{SMI}}$ Enable 0: Disabled (default) 1: Enabled
1	VBAT Event to $\overline{\text{SMI}}$ Enable 0: Disabled (default) 1: Enabled
0	VDD Event to $\overline{\text{SMI}}$ Enable 0: Disabled (default) 1: Enabled

11.0 Voltage Level Monitor (VLM) (Continued)

11.5.6 Voltage Event to IRQ Register 0 (VEVIRQ0)

This register is one of two registers that controls event routing to IRQ.

Location: Offset 04h

Type: R/W

Bit	7	6	5	4	3	2	1	0
Name	VSB Event to IRQ Enable	AVI6 Event to IRQ Enable	AVI5 Event to IRQ Enable	AVI4 Event to IRQ Enable	AVI3 Event to IRQ Enable	AVI2 Event to IRQ Enable	AVI1 Event to IRQ Enable	AVI0 Event to IRQ Enable
Reset	0	0	0	0	0	0	0	0

Bit	Description
7	VSB Event to IRQ Enable 0: Disabled (default) 1: Enabled
6-0	AVI6-0 Event to IRQ Enable 0: Disabled (default) 1: Enabled

11.5.7 Voltage Event to IRQ Register 1 (VEVIRQ1)

This register is one of two registers that controls routing to IRQ.

Location: Offset 05h

Type: R/W

Bit	7	6	5	4	3	2	1	0
Name	Reserved		TMS3 Event to IRQ Enable	TMS2 Event to IRQ Enable	TMS1 Event to IRQ Enable	AV_{DD} Event to IRQ Enable	VBAT Event to IRQ Enable	VDD Event to IRQ Enable
Reset	0	0	0	0	0	0	0	0

Bit	Description
7-6	Reserved
5	TMS3 Event to IRQ Enable 0: Disabled (default) 1: Enabled
4	TMS2 Event to IRQ Enable 0: Disabled (default) 1: Enabled
3	TMS1 Event to IRQ Enable 0: Disabled (default) 1: Enabled

11.0 Voltage Level Monitor (VLM) (Continued)

Bit	Description
2	AV_{DD} Event to IRQ Enable 0: Disabled (default) 1: Enabled
1	VBAT Event to IRQ Enable 0: Disabled (default) 1: Enabled
0	VDD Event to IRQ Enable 0: Disabled (default) 1: Enabled

11.5.8 Voltage ID Register (VID)

This register indicates the configuration of the power supply regulator for the CPU(s).

Location: Offset 06h

Type: Varies per bit

Bit	7	6	5	4	3	2	1	0
Name	CPU VID Select		Reserved	VID Value				
Reset	0	0	0	X	X	X	X	X

Bit	Type	Description
7-6	R/W	CPU Voltage ID Select. This field selects which of the CPUs' VID pins is read in the Voltage ID Value field. Bits 7 6 Voltage ID 0 0 CPU0 (default) 0 1 CPU1 Other Reserved
5		Reserved
4-0	RO	Voltage ID Value. Returns the current value of the VID inputs selected by the "CPU VID Select field". The pins used for the VID field are defined by "VID0 and VID1 Route Select" bits of the SuperI/O Configuration 5 register (See Section 2.8.6).

11.0 Voltage Level Monitor (VLM) (Continued)

11.5.9 Voltage Conversion Rate Register (VCNVR)

This register indicates time related specification for the VLM.

Location: Offset 07h

Type: R/W

Bit	7	6	5	4	3	2	1	0
Name	Reserved		Channel Delay			Conversion Period		
Reset	0	0	0	0	0	0	0	0

Bit	Description																																
7-6	Reserved																																
5-3	<p>Channel Delay. These bits define the sampling delay. The sampling delay helps guarantee the accuracy of the sampled value when switching from one channel to another.</p> <p>Bits</p> <table border="0"> <tr> <td>5</td> <td>4</td> <td>3</td> <td>Delay (μSec)</td> </tr> <tr> <td>0</td> <td>0</td> <td>0</td> <td>40 (default)</td> </tr> <tr> <td>0</td> <td>0</td> <td>1</td> <td>80</td> </tr> <tr> <td>0</td> <td>1</td> <td>0</td> <td>160</td> </tr> <tr> <td colspan="3">Others</td> <td>Reserved</td> </tr> </table>	5	4	3	Delay (μSec)	0	0	0	40 (default)	0	0	1	80	0	1	0	160	Others			Reserved												
5	4	3	Delay (μSec)																														
0	0	0	40 (default)																														
0	0	1	80																														
0	1	0	160																														
Others			Reserved																														
2-0	<p>Conversion Period. These bits define the period of time between reconversions of all enabled channels. V_{BAT} (channel 9) is converted at the first of every 1024 conversion periods.</p> <p>Bits</p> <table border="0"> <tr> <td>2</td> <td>1</td> <td>0</td> <td>Conversion Period</td> </tr> <tr> <td>0</td> <td>0</td> <td>0</td> <td>2 seconds (default)</td> </tr> <tr> <td>0</td> <td>0</td> <td>1</td> <td>1 second</td> </tr> <tr> <td>0</td> <td>1</td> <td>0</td> <td>0.5 seconds</td> </tr> <tr> <td>0</td> <td>1</td> <td>1</td> <td>0.1 seconds</td> </tr> <tr> <td>1</td> <td>0</td> <td>0</td> <td>0.05 seconds</td> </tr> <tr> <td>1</td> <td>0</td> <td>1</td> <td>0.02 seconds</td> </tr> <tr> <td colspan="3">Others</td> <td>Reserved</td> </tr> </table>	2	1	0	Conversion Period	0	0	0	2 seconds (default)	0	0	1	1 second	0	1	0	0.5 seconds	0	1	1	0.1 seconds	1	0	0	0.05 seconds	1	0	1	0.02 seconds	Others			Reserved
2	1	0	Conversion Period																														
0	0	0	2 seconds (default)																														
0	0	1	1 second																														
0	1	0	0.5 seconds																														
0	1	1	0.1 seconds																														
1	0	0	0.05 seconds																														
1	0	1	0.02 seconds																														
Others			Reserved																														

11.0 Voltage Level Monitor (VLM) (Continued)

11.5.10 VLM Configuration Register (VLMCFG)

This register selects the channels and sets global configuration (not channel specific) values.

Location: Offset 08h

Type: R/W

Bit	7	6	5	4	3	2	1	0
Name	Reserved						External VREF	Standby Mode Enable
Reset	0	0	0	0	0	0	1	1

Bit	Description
7-2	Reserved
1	<p>External VREF</p> <p>This bit selects either the internal, or external reference voltage as a reference for the A/D Converter. Note that if either the VLM or TMS specify the use of an internal V_{REF} the internal V_{REF} will be used by both these modules.</p> <p>0: Internal V_{REF} in use 1: External V_{REF} in use (default)</p>
0	<p>Standby Mode Enable</p> <p>0: Monitoring operation enabled 1 Standby mode enabled (default)</p>

11.5.11 VLM Bank Select Register (VLMBS)

This register selects a bank and its associated channels.

Location: Offset 09h

Type: R/W

Bit	7	6	5	4	3	2	1	0
Name	Reserved			Bank Select Value				
Reset	0	0	0	0	0	0	0	0

Bit	Description																																																															
7-5	Reserved																																																															
4-0	<p>Bank Select Value. These bits contain the binary value that selects a bank and its associated channels for configuration and viewing.</p> <table border="0"> <tr> <td>4</td> <td>3</td> <td>2</td> <td>1</td> <td>0</td> <td>Bank</td> <td>Function</td> </tr> <tr> <td>0</td> <td>0</td> <td>0</td> <td>0</td> <td>0</td> <td>0</td> <td>Channel 0 (default)</td> </tr> <tr> <td>0</td> <td>0</td> <td>0</td> <td>0</td> <td>1</td> <td>1</td> <td>Channel 1</td> </tr> <tr> <td colspan="7">.....</td> </tr> <tr> <td>0</td> <td>1</td> <td>1</td> <td>0</td> <td>1</td> <td>10</td> <td>Channel 10</td> </tr> <tr> <td>0</td> <td>1</td> <td>1</td> <td>0</td> <td>1</td> <td>10</td> <td>Channel 11 - Temperature</td> </tr> <tr> <td colspan="7">.....</td> </tr> <tr> <td>0</td> <td>1</td> <td>1</td> <td>0</td> <td>1</td> <td>10</td> <td>Channel 13 - Temperature</td> </tr> <tr> <td colspan="6">Other</td> <td>Reserved</td> </tr> </table>	4	3	2	1	0	Bank	Function	0	0	0	0	0	0	Channel 0 (default)	0	0	0	0	1	1	Channel 1							0	1	1	0	1	10	Channel 10	0	1	1	0	1	10	Channel 11 - Temperature							0	1	1	0	1	10	Channel 13 - Temperature	Other						Reserved
4	3	2	1	0	Bank	Function																																																										
0	0	0	0	0	0	Channel 0 (default)																																																										
0	0	0	0	1	1	Channel 1																																																										
.....																																																																
0	1	1	0	1	10	Channel 10																																																										
0	1	1	0	1	10	Channel 11 - Temperature																																																										
.....																																																																
0	1	1	0	1	10	Channel 13 - Temperature																																																										
Other						Reserved																																																										

11.0 Voltage Level Monitor (VLM) (Continued)

11.5.12 Voltage Channel Configuration and Status Register (VCHCFST)

This register indicates the current channel status.

Location: Offset 0Ah - Banks 0 through 10

Type: Varies per bit

Bit	7	6	5	4	3	2	1	0
Name	End of Conversion	Reserved		ALARM Output Enable	Reserved	Channel High Limit Exceeded	Channel Low Limit Exceeded	Channel Enable
Reset	0	0	0	0	0	0	0	0

Location: Offset 0Ah - Bank 11 through 13

Type: Varies per bit

Bit	7	6	5	4	3	2	1	0
Name	End of Conversion	Reserved		ALARM Output Enable	Channel Overtemp Limit Exceeded	Channel High Limit Exceeded	Channel Low Limit Exceeded	Channel Enable
Reset	0	0	0	0	0	0	0	0

Bit	Type	Description
7	RW1C	End of Conversion. This bit indicates that RDCHV register holds new data. It is set when new data is written into RDCHV as a result of completing a conversion for this channel. It is cleared by writing 1 to this bit. 0: No new data (default) 1: New data not yet read
6-5		Reserved
4	R/W	ALARM Output Enable 0: Disabled (default) 1: Enabled
3	RW1C	Channel Overtemperature Limit Exceeded. Banks 11 through 13. 0: Voltage read, indicating overtemperature limit exceeded (default) 1: $\overline{\text{OTS}}$ signal set, indicating overtemperature limit exceeded
2	RW1C	Channel High Limit Exceeded 0: Voltage lower than limit (default) 1: Voltage higher than limit
1	RW1C	Channel Low Limit Exceeded 0: Voltage higher than limit (default) 1: Voltage lower than limit
0	R/W	Channel Enable 0: Disabled (default) 1: Enabled

11.0 Voltage Level Monitor (VLM) (Continued)

11.5.13 Read Channel Voltage Register (RDCHV)

This register holds the last voltage readout for each channel. The value is an 8-bit unsigned integer of the voltage measured by the channel.

Location: Offset 0Bh - Banks 0 to 13

Type: RO

Bit	7	6	5	4	3	2	1	0
Name	Channel Voltage Value							
Reset	0	0	0	0	0	0	0	0

11.5.14 Channel Voltage High Limit Register (CHVH)

This register holds the voltage high limit value that is compared with the voltage reading.

Location: Offset 0Ch - Banks 0 through 13

Type: R/W

Bit	7	6	5	4	3	2	1	0
Name	Channel Voltage High Limit Value							
Reset	1	1	1	1	1	1	1	1

11.5.15 Channel Voltage Low Limit Register (CHVL)

This register holds the voltage low limit value that is compared with the voltage reading.

Location: Offset 0Dh - Banks 0 through 13

Type: R/W

Bit	7	6	5	4	3	2	1	0
Name	Channel Voltage Low Limit Value							
Reset	0	0	0	0	0	0	0	0

11.5.16 Overtemperature Shutdown Limit Register (OTSL)

This register defines the overtemperature shutdown limit for banks 11 to 13. Its power-up default is the maximum voltage readout.

Location: Offset 0Eh Banks 11 to 13

Type: R/W

Bit	7	6	5	4	3	2	1	0
Name	Overtemperature Shutdown Limit Value							
Reset	1	1	1	1	1	1	1	1

11.0 Voltage Level Monitor (VLM) (Continued)

11.6 VLM REGISTER BITMAP

11.6.1 VLM Control and Status Registers

Register		Bits							
Offset	Mnemonic	7	6	5	4	3	2	1	0
00h	VEVSTS0	VSB ALARM Event Status	AVI6 ALARM Event Status	AVI5 ALARM Event Status	AVI4 ALARM Event Status	AVI3 ALARM Event Status	AVI2 ALARM Event Status	AVI1 ALARM Event Status	AVI0 ALARM Event Status
01h	VEVSTS1	Reserved		TMS3 ALERT or OTS Event Status	TMS2 ALERT or OTS Event Status	TMS1 ALERT or OTS Event Status	AV _{DD} ALARM Event Status	VBAT ALARM Event Status	VDD ALARM Event Status
02h	VEVSMI0	VSB Event to SMI Enable	AVI6 Event to SMI Enable	AVI5 Event to SMI Enable	AVI4 Event to SMI Enable	AVI3 Event to SMI Enable	AVI2 Event to SMI Enable	AVI1 Event to SMI Enable	AVI0 Event to SMI Enable
03h	VEVSMI1	Reserved		TMS3 Event to SMI Enable	TMS2 Event to SMI Enable	TMS1 Event to SMI Enable	AV _{DD} Event to SMI Enable	VBAT Event to SMI Enable	VDD Event to SMI Enable
04h	VEVIRQ0	VSB Event to IRQ Enable	AVI6 Event to IRQ Enable	AVI5 Event to IRQ Enable	AVI4 Event to IRQ Enable	AVI3 Event to IRQ Enable	AVI2 Event to IRQ Enable	AVI1 Event to IRQ Enable	AVI0 Event to IRQ Enable
05h	VEVIRQ1	Reserved		TMS3 Event to IRQ Enable	TMS2 Event to IRQ Enable	TMS1 Event to IRQ Enable	AV _{DD} Event to IRQ Enable	VBAT Event to IRQ Enable	VDD Event to IRQ Enable
06h	VID	CPU VID Select		Reserved	VID Value				
07h	VCNVR	Reserved		Channel Delay			Conversion Period		
08h	VLMCFG	Reserved						External VREF	Standby Mode Enable
09h	VLMBS	Reserved			Bank Select Value				

11.6.2 VLM Channel Registers

Register		Bits							
Offset	Mnemonic	7	6	5	4	3	2	1	0
0Ah (Bank 0-10)	VCHCFST	End of Conversion	Reserved		ALARM Output Enable	Reserved	Channel High Limit Exceeded	Channel Low Limit Exceeded	Channel Enable
0Ah (Bank 11-13)	VCHCFST	End of Conversion	Reserved		ALARM Output Enable	Channel Overtemp Limit Exceeded	Channel High Limit Exceeded	Channel Low Limit Exceeded	Channel Enable

11.0 Voltage Level Monitor (VLM) (Continued)

Register		Bits
0Bh (Bank 0-13)	RDCHV	Channel Voltage Value
0Ch (Bank 0-13)	CHVH	Channel Voltage High Limit Value
0Dh (Bank 0-13)	CHVL	Channel Voltage Low Limit Value
0Eh (Bank 11-13)	OTSL	Overtemperature Shutdown Limit Value
0Fh		Reserved

11.7 USAGE HINTS

11.7.1 Calculating the Channel Delay

The channel delay is the interval between the time a new channel is selected and the time the channel voltage can be measured. The reason for this delay is to allow the voltage to charge all internal capacitors to guarantee accuracy of the measurement. This delay period depends on characteristics of the input (resistance and capacitance) and of the external circuit. Figure 39 shows the schematic of the input and its equivalent R-C circuit. The sampling time should be long enough to guarantee that the voltage settles on the capacitor C_S . The voltage on C_S should be stable before the measurement starts. The R_{AIN} and C_{AIN} values represent the input path serial resistance and parallel capacitance. R_{AIN} is the serial resistance of the multiplexer, Sample & Hold switch and other parasitic resistors. C_{AIN} is the parallel capacitance of the input pin, pad, lead-frame, C_S , etc. The required sampling time is determined by R_{AIN} and C_{AIN} together with the input source resistance R_{SOURCE} and parasitic capacitance C_P . Table 52 can be used as a reference for calculating the sample time. Channel Delay of the VCNVR register should be programmed accordingly.

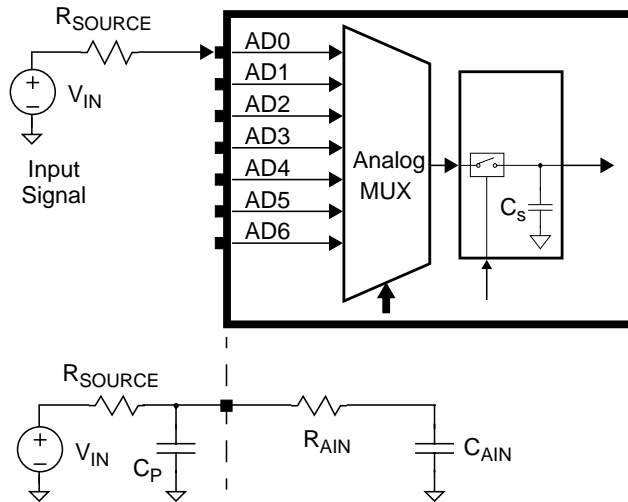

C_P is the parasitic capacitor including the external elements (PCB capacitance etc.).

R_{AIN} is the equivalent serial resistance of all serial elements inside the chip (pin, bonding, MUX, Sample & Hold switch, layout).

C_S is the sampling capacitor.

C_{AIN} is the equivalent parallel capacitance of the chip parasitic capacitances and the C_S capacitor.

Figure 39. Analog Input Schematic Diagram and Equivalent R-C Circuit

11.0 Voltage Level Monitor (VLM) (Continued)

Table 52. Delay Setting Example

External Elements		Delay Time (nS)
R _{SOURCE} [KΩ]	C _P [pF]	
5	0.1	15
	1	110
	10	900
	30	3200
27.5	0.1	25
	1	210
	10	2220
	30	7900
50	0.1	45
	1	430
	10	3350
	30	11400

11.7.2 Measuring Out of Range Positive and Negative Voltages

Only voltages within the range of 0V to $2.45 \cdot V_{REF}$ can be measured by the module. To measure voltages out of this range, any of the external measurement pins can be used, with the addition of external resistors that should be used as voltage dividers. (See Figure 40.)

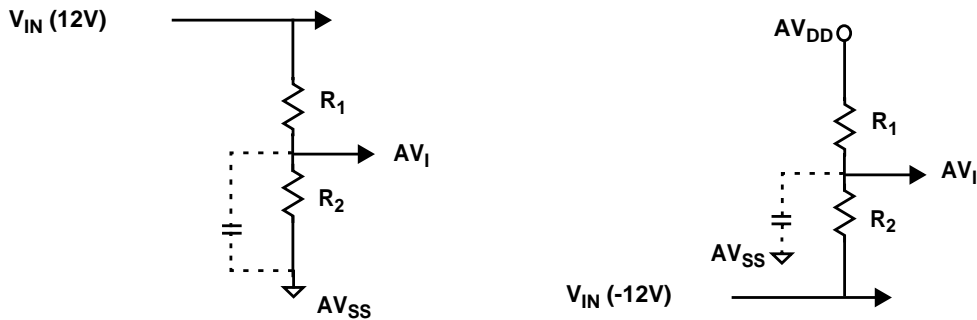

Figure 40. Measurement of Positive and Negative Voltages

12.0 Temperature Sensor (TMS)

12.1 OVERVIEW

The Temperature Sensor (TMS) is a diode input temperature sensor which consists of a Delta-Sigma Analog to Digital (A/D) converter and a digital overtemperature detector. Both of these elements conform to Advance Configuration and Power Interface (ACPI) requirements for thermal management.

The TMS senses its own temperature and the temperature of two target ICs by measuring the voltage drop of diode(s) placed on the target IC's die. A host can query the TMS at any time to read the temperature of remote diode(s) as well as the local temperature. An $\overline{\text{ALERT}}$ interrupt output becomes active when the temperature goes above T_{HIGH} or below T_{LOW} . The host may program the two thresholds for each sensing channel to define an operation window. Overtemperature Shutdown ($\overline{\text{OTS}}$) output becomes active when the temperature exceeds the programmable limit T_{OS} .

12.2 FUNCTIONAL DESCRIPTION

The TMS incorporates a band-gap temperature sensor using a local and remote diode(s) and an 8-bit Delta-Sigma Analog-to-Digital Converter (A/D converter). Once enabled and put in active (non-standby mode), the TMS continuously measures temperature of up to one internal diode and two remote diodes. TMS readings are available at all times via the host interface. When $\overline{\text{SLPS3}}$ input becomes inactive, the conversion is stopped and no new results are generated until both $\overline{\text{SLPS3}}$ becomes active, and the internal wake up sequence is completed. TMS registers are maintained by V_{SB} during this period.

A digital comparator is also incorporated to compare temperature readings to user-programmable limits. $\overline{\text{OTS}}$ output indicates that the result of the comparison exceeds the limit preset in the Channel Overtemperature Limit register. $\overline{\text{ALERT}}$ output indicates that the result of the comparison is not within limits preset in the Channel Temperature High or Low Limit (CHTH and CHTL) registers.

Figure 41 shows a simplified block diagram of the TMS. It represents only the local diode and one remote diode (even though there are actually two remote diodes in addition to the local diode, and one or three $\overline{\text{OTS}}$ signals; combined or one for each diode sensor).

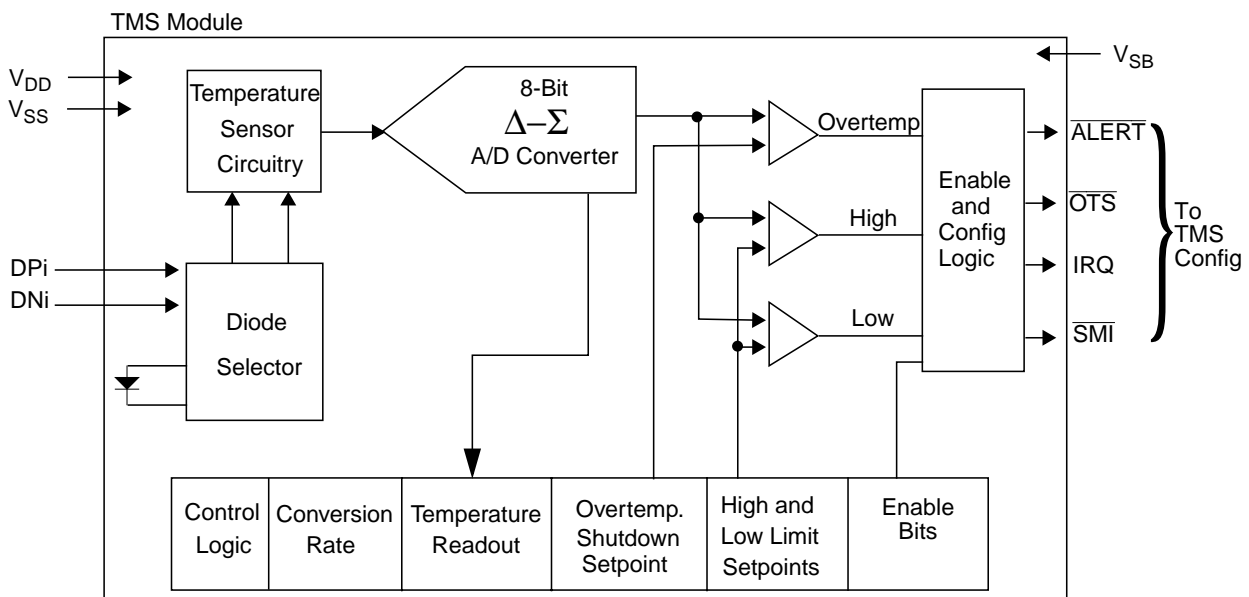

Figure 41. TMS Simplified Block Diagram

12.0 Temperature Sensor (TMS) (Continued)

12.2.1 Register Bank Overview

Three register banks control TMS operation. The first part of each bank is a set of registers common to all banks. The second part of each bank contains registers which are specific to that bank. All registers use the same 16-byte address space to indicate offsets 00h through 0Fh. The software selects the currently active bank using the Bank Select register (TMSBS) - See Figure 42. Bank zero is the selected after reset.

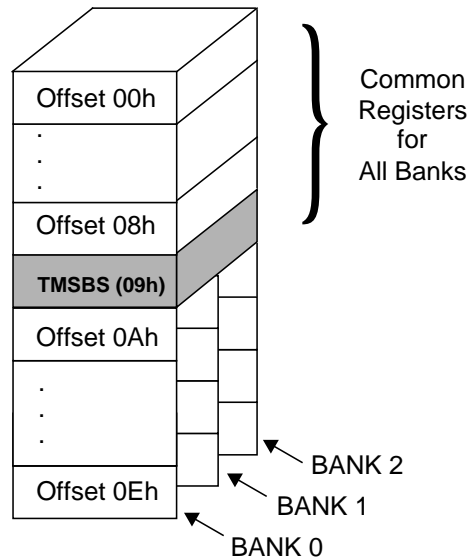

Figure 42. Register Bank Architecture

12.2.2 T_{OS} , T_{HIGH} and T_{LOW} Limits, \overline{OTS} and \overline{ALERT} Output, IRQ and \overline{SMI}

The temperature reading is compared to three limits: T_{OS} , T_{HIGH} and T_{LOW} . If the temperature reading is outside any of these limits, the respective status bit (Channel Overtemperature Limit Exceeded, Channel Temp High Limit Exceeded or the Channel Temp Low Limit Exceeded) in the TCHCFST register is set. The status bit stays active until it is cleared by the software. An ALERT status bit in the TEVSTS register is set when the Channel Temp High Limit Exceeded or the Channel Temp Low Limit Exceeded bit for the respective channel is set. The channel's Overtemperature Event status in the TEVSTS register is set when the Channel Overtemperature Limit Exceeded bit is set.

The \overline{OTS} output is used to indicate to the system that the overtemperature limit has been exceeded. The \overline{OTS} Output Enable bit in the TCHCFST register, enables the \overline{OTS} output to be active when the OTS status of the channel is active.

The \overline{ALERT} output is used to indicate to the system that the current temperature is outside the high/low limits. The \overline{ALERT} output Enable bit in the TCHCFST register, enables the \overline{ALERT} output to be active when the "Channel Temp High Limit Exceeded" or the "Channel Temp Low Limit Exceeded" status bit in TCHCFST register is set.

The \overline{SMI} output generates an interrupt if any enabled \overline{SMI} event occurs. Each bit in the TEVSTS register has a corresponding \overline{SMI} Enable bit in the TEVSMI register. When any status bit and its corresponding \overline{SMI} Enable bit are set the \overline{SMI} output is active.

The IRQ output generates an interrupt if any enabled IRQ event occurs. Each bit in the TEVSTS register has a corresponding IRQ Enable bit in the TEVIRQ register. When any status bit and its corresponding IRQ Enable bit are set the IRQ output is active.

12.0 Temperature Sensor (TMS) (Continued)

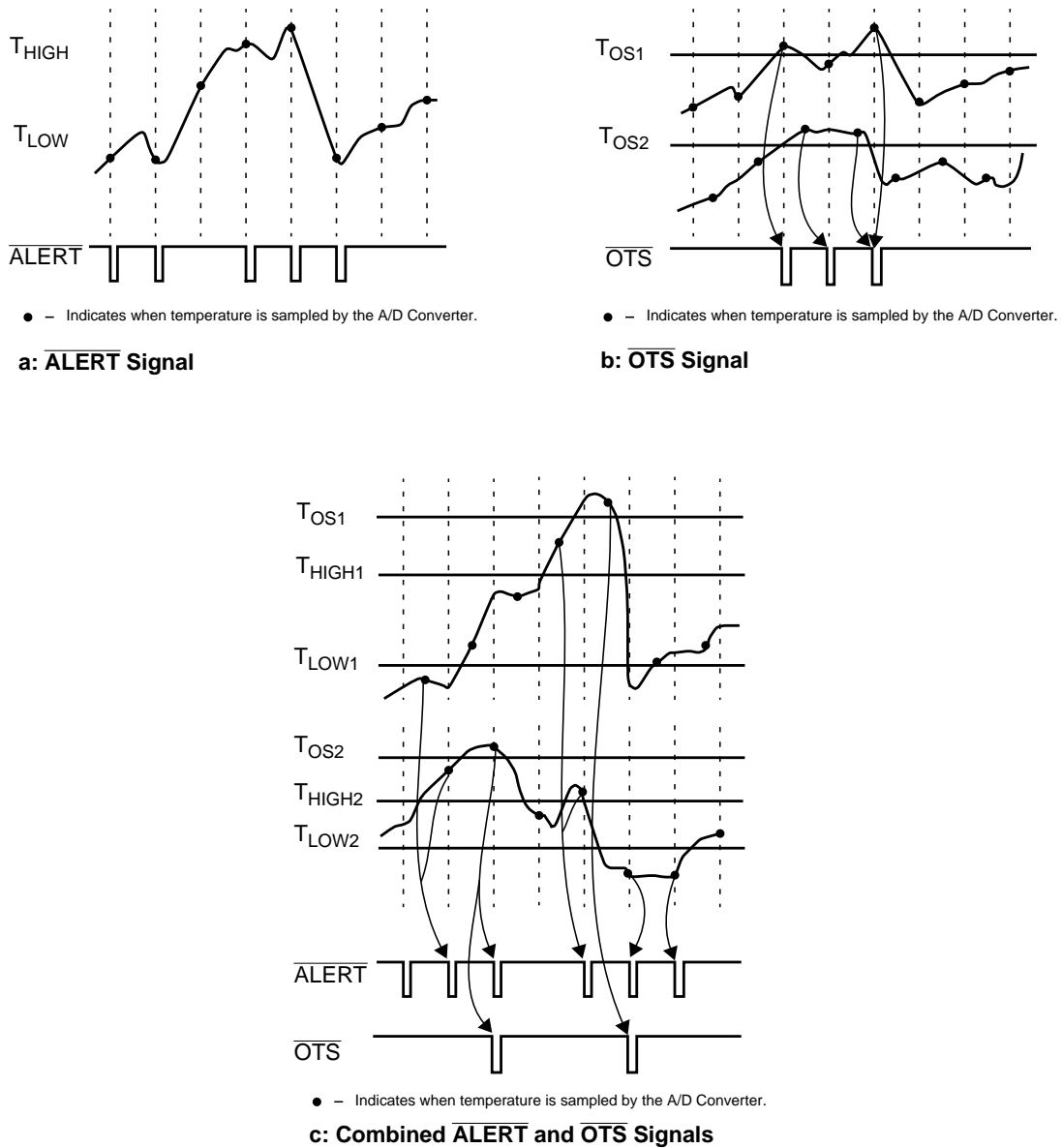

Figure 43. $\overline{\text{OTS}}$ and $\overline{\text{ALERT}}$ Temperature Response Diagrams

12.2.3 ALERT Response Read Sequence

The Read Channel Temperature register (RDCHT) holds the temperature value most recently read from the channel. The Temperature Event Status register (TEVSTS) indicates any ALERT detected as long as V_{SB} is maintained. ALERTs are cleared by software.

When an IRQ or $\overline{\text{SMI}}$ is received, check the TEVSTS register to see which of the sensors detected an out-of-limit readout, access the channel readouts, read the current value and status information, and clear any pending status bits.

12.2.4 Power-On Reset Default States

TMS always powers up in a known state. TMS power-up default conditions are:

1. Local temperature set to 0°C.
2. Remote temperature set to 0°C until the TMS senses a diode present on D+ and D- input pins.
3. Status register set to 00h.
4. Command register set to 00h; $\overline{\text{ALERT}}$ and $\overline{\text{OTS}}$ enabled, Standby mode deactivated.

12.0 Temperature Sensor (TMS) (Continued)

5. Local and Remote T_{OS} set to 127°C
6. Local and Remote T_{HIGH} set to 127°C
7. Local and Remote T_{LOW} set to -55°C

12.2.5 Temperature Data Format

Temperature data is stored in the RDCHT, CHTH, CHTL and CHOTL registers as an 8-bit, 2's complement word with a Least Significant Bit (LSB) equal to 1°C .

Table 53. Temperature Formats

Temperature ($^{\circ}\text{C}$)	Digital Output	
	Binary	Hex
+125	0111 1101	7Dh
+25	0001 1001	19h
+1	0000 0001	01h
0	0000 0000	00h
-1	1111 1111	FFh
-25	1110 0111	E7h

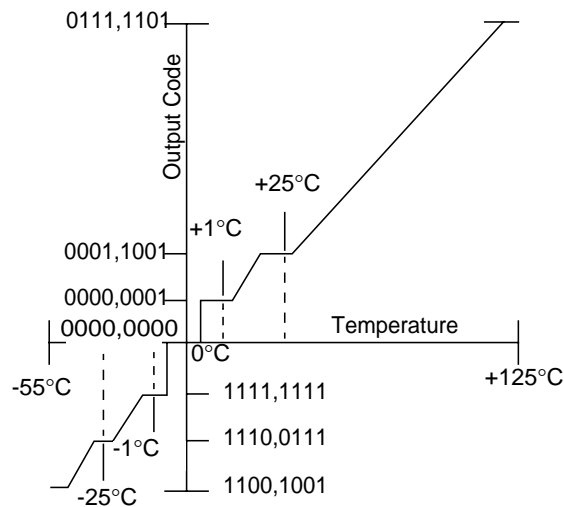

Figure 44. Temperature-to-Digital Transfer Function (Non-linear scale for clarity)

12.2.6 Standby Mode

Standby mode is enabled by setting the Standby Mode bit in the TMSCFG register to 1 (default). Standby mode disables the conversion process to reduce power supply current. During standby mode, all registers retain their values and can be accessed by software (as usual).

12.2.7 Diode Fault Detection

At the beginning of each conversion, the TMS goes through a diode fault detection sequence. If the DxP input is shorted to V_{DD} or floating, then the temperature reading will be $+127^{\circ}\text{C}$ and the Open bit of the TCHCFST register is set, which activates the $\overline{\text{ALERT}}$ and $\overline{\text{OTS}}$ outputs on completion of a conversion. If DxP is shorted to GND or DxN, the temperature reading is 0°C and the Temperature Low Limit bit of the TCHCFST register is not set.

12.0 Temperature Sensor (TMS) (Continued)

12.3 TMS REGISTERS

The TMS registers are divided into two groups: TMS Control and Status registers, and TMS channel registers. The TMS channel registers are duplicated for each channel.

The register maps in this chapter use the following abbreviations for Type:

- R/W = Read/Write
- R = Read from a specific address returns the value of a specific register. Write to the same address is to a different register.
- W = Write
- RO = Read Only
- R/W1C = Read/Write 1 to Clear. Writing 1 to a bit clears it to 0. Writing 0 has no effect.

12.3.1 TMS Register Map

Table 54. TMS Control and Status Register Map

Offset	Mnemonic	Register Name	Type	Section
00h	TEVSTS	Temperature Event Status	RO	12.3.2
01h	Reserved			
02h	TEVSMI	Temperature Event to SMI	R/W	12.3.3
03h	Reserved			
04h	TEVIRQ	Temperature Event to IRQ	R/W	12.3.4
05h-07h	Reserved			
08h	TMSCFG	TMS Configuration	R/W	12.3.5
09h	TMSBS	TMS Bank Select	R/W	12.3.6

Table 55. TMS Channel Register Map (One per Channel)

Offset	Mnemonic	Register Name	Type	Section
0Ah	TCHCFST	Temperature Channel Configuration and Status	Varies per bit	12.3.7
0Bh	RDCHT	Read Channel Temperature	RO	12.3.8
0Ch	CHTH	Channel Temperature High Limit	R/W	12.3.9
0Dh	CHTL	Channel Temperature Low Limit	R/W	12.3.10
0Eh	CHOTL	Channel Overtemperature Limit	R/W	12.3.11
0Fh	Reserved			

12.0 Temperature Sensor (TMS) (Continued)

12.3.2 Temperature Event Status Register (TEVSTS)

This register is set to 00h on power-up of AV_{DD}. It indicates which of the corresponding three TMS events has occurred.

Location: Offset 00h

Type: RO

Bit	7	6	5	4	3	2	1	0
Name	Reserved		Local Overtemp Event Status	Local ALERT Event Status	Remote 2 Overtemp Event Status	Remote 2 ALERT Event Status	Remote 1 Overtemp Event Status	Remote 1 ALERT Event Status
Reset	0	0	0	0	0	0	0	0

Bit	Description
7-6	Reserved
5	Local Overtemperature Event Status 0: Event not detected (default) 1: Event detected
4	Local ALERT Event Status 0: Event not detected (default) 1: Event detected
3	Remote 2 Overtemperature Event Status 0: Event not detected (default) 1: Event detected
2	Remote 2 ALERT Event Status 0: Event not detected (default) 1: Event detected
1	Remote 1 Overtemperature Event Status 0: Event not detected (default) 1: Event detected
0	Remote 1 ALERT Event Status 0: Event not detected (default) 1: Event detected

12.0 Temperature Sensor (TMS) (Continued)

12.3.3 Temperature Event to $\overline{\text{SMI}}$ Register (TEVSMI)

This register controls temperature event routing to the $\overline{\text{SMI}}$.

Location: Offset 02h

Type: R/W

Bit	7	6	5	4	3	2	1	0
Name	Reserved		Local Overtemp Event to $\overline{\text{SMI}}$ Enable	Local ALERT Event to $\overline{\text{SMI}}$ Enable	Remote 2 Overtemp Event to $\overline{\text{SMI}}$ Enable	Remote 2 ALERT Event to $\overline{\text{SMI}}$ Enable	Remote 1 Overtemp Event to $\overline{\text{SMI}}$ Enable	Remote 1 ALERT Event to $\overline{\text{SMI}}$ Enable
Reset	0	0	0	0	0	0	0	0

Bit	Description
7-6	Reserved
5	Local Overtemperature Event to $\overline{\text{SMI}}$ Enable 0: Disabled (default) 1: Enabled
4	Local ALERT Event to $\overline{\text{SMI}}$ Enable 0: Disabled (default) 1: Enabled
3	Remote 2 Overtemperature Event to $\overline{\text{SMI}}$ Enable 0: Disabled (default) 1: Enabled
2	Remote 2 ALERT Event to $\overline{\text{SMI}}$ Enable 0: Disabled (default) 1: Enabled
1	Remote 1 Overtemperature Event to $\overline{\text{SMI}}$ Enable 0: Disabled (default) 1: Enabled
0	Remote 1 ALERT Event to $\overline{\text{SMI}}$ Enable 0: Disabled (default) 1: Enabled

12.0 Temperature Sensor (TMS) (Continued)

12.3.4 Temperature Event to IRQ Register (TEVIRQ)

This register controls temperature event routing to the IRQ.

Location: Offset 04h

Type: R/W

Bit	7	6	5	4	3	2	1	0
Name	Reserved		Local Overtemp Event to IRQ Enable	Local ALERT Event to IRQ Enable	Remote 2 Overtemp Event to IRQ Enable	Remote 2 ALERT Event to IRQ Enable	Remote 1 Overtemp Event to IRQ Enable	Remote 1 ALERT Event to IRQ Enable
Reset	0	0	0	0	0	0	0	0

Bit	Description
7-6	Reserved
5	Local Overtemperature Event to IRQ Enable 0: Disabled (default) 1: Enabled
4	Local ALERT Event to IRQ Enable 0: Disabled (default) 1: Enabled
3	Remote 2 Overtemperature Event to IRQ Enable 0: Disabled (default) 1: Enabled
2	Remote 2 ALERT Event to IRQ Enable 0: Disabled (default) 1: Enabled
1	Remote 1 Overtemperature Event to IRQ Enable 0: Disabled (default) 1: Enabled
0	Remote 1 ALERT Event to IRQ Enable 0: Disabled (default) 1: Enabled

12.0 Temperature Sensor (TMS) (Continued)

12.3.5 TMS Configuration Register (TMSCFG)

This register selects channels and sets global configuration (not channel specific) values.

Location: Offset 08h

Type: R/W

Bit	7	6	5	4	3	2	1	0
Name	Reserved						External VREF	Standby Mode
Reset	0	0	0	0	0	0	1	1

Bit	Description
7-2	Reserved
1	External VREF This bit selects either internal or external reference voltage for conversion. Note that if either the VLM or TMS are configured to use the internal V_{REF} , the internal V_{REF} will be used by both. 0: Internal VREF in use 1: External VREF in use (default)
0	Standby Mode 0: Monitoring operation enabled 1: Standby mode (default)

12.3.6 TMS Bank Select Register (TMSBS)

This register selects banks and sets global configuration (not bank specific) values.

Location: Offset 09h

Type: R/W

Bit	7	6	5	4	3	2	1	0
Name	Reserved				Bank Select			
Reset	0	0	0	0	0	0	0	0

Bit	Description																														
7-4	Reserved																														
3-0	Bank Select. These bits select the bank for configuration and viewing. Bits <table border="1"> <thead> <tr> <th>3</th> <th>2</th> <th>1</th> <th>0</th> <th>Bank</th> <th>Function</th> </tr> </thead> <tbody> <tr> <td>0</td> <td>0</td> <td>0</td> <td>0</td> <td>0</td> <td>Remote diode 1</td> </tr> <tr> <td>0</td> <td>0</td> <td>0</td> <td>1</td> <td>1</td> <td>Remote diode 2</td> </tr> <tr> <td>0</td> <td>0</td> <td>1</td> <td>0</td> <td>2</td> <td>Local diode</td> </tr> <tr> <td colspan="4">Other</td> <td>Reserved</td> <td></td> </tr> </tbody> </table>	3	2	1	0	Bank	Function	0	0	0	0	0	Remote diode 1	0	0	0	1	1	Remote diode 2	0	0	1	0	2	Local diode	Other				Reserved	
3	2	1	0	Bank	Function																										
0	0	0	0	0	Remote diode 1																										
0	0	0	1	1	Remote diode 2																										
0	0	1	0	2	Local diode																										
Other				Reserved																											

12.0 Temperature Sensor (TMS) (Continued)

12.3.7 Temperature Channel Configuration and Status Register (TCHCFST)

This register is set to 00h on power-up of AV_{DD}. Bits 3-1 indicate which of three temperature limits has been exceeded. Write 1 to clear any of these bits. Writing 0 has no effect.

Location: Offset 0Ah

Type: Varies per bit

Bit	7	6	5	4	3	2	1	0
Name	End of Conversion	Open	$\overline{\text{OTS}}$ Output Enable	ALERT Output Enable	Channel Overtemp Limit Exceeded	Channel Temp High Limit Exceeded	Channel Temp Low Limit Exceeded	Channel Enable
Reset	0	0	0	0	0	0	0	0

Bit	Type	Description
7	R/W1C	End of Conversion. This bit reflects the data in the RDCHT register. It is cleared by writing 1 to this bit. It is set when new data is written to the RDCHT register. 0: No new data (default) 1: New data not yet read
6	R/W1C	Open 0: No fault (default) 1: Remote diode continuity (open circuit) fault
5	R/W	$\overline{\text{OTS}}$ Output Enable 0: Disabled (default) 1: Enabled
4	R/W	ALERT Output Enable 0: Disabled (default) 1: Enabled
3	R/W1C	Channel Overtemperature Limit Exceeded 0: Overtemperature lower than limit (default) 1: Overtemperature higher than limit
2	R/W1C	Channel Temperature High Limit Exceeded 0: Temperature lower than limit (default) 1: Temperature higher than limit
1	R/W1C	Channel Temperature Low Limit Exceeded. This bit is set whenever a value lower than the value specified in CHTL is written into RDCHT. It is cleared by writing 1 to it. 0: Temperature higher than limit (default) 1: Temperature lower than limit
0	R/W	Channel Enable 0: Disabled (default) 1: Enabled

12.0 Temperature Sensor (TMS) (Continued)

12.3.8 Read Channel Temperature Register (RDCHT)

This register holds the last temperature readout for each channel. The value is an 8-bit, 2's complement word with a Least Significant Bit (LSB) equal to 1° C, of the temperature measured by the channel.

Location: Offset 0Bh

Type: RO

Bit	7	6	5	4	3	2	1	0
Name	Channel Temperature Value							
Reset	0	0	0	0	0	0	0	0

12.3.9 Channel Temperature High Limit Register (CHTH)

This register holds the temperature high limit value that is compared with the temperature reading.

Location: Offset 0Ch

Type: R/W

Bit	7	6	5	4	3	2	1	0
Name	Channel Temperature High Limit Value							
Reset	0	1	1	1	1	1	1	1

12.3.10 Channel Temperature Low Limit Register (CHTL)

This register holds the temperature low limit value that is compared with the temperature reading.

Location: Offset 0Dh

Type: R/W

Bit	7	6	5	4	3	2	1	0
Name	Channel Temperature Low Limit Value							
Reset	1	1	0	0	1	0	0	1

12.3.11 Channel Overtemperature Limit Register (CHOTL)

This register holds the overtemperature limit value that is compared with the temperature reading.

Location: Offset 0Eh

Type: R/W

Bit	7	6	5	4	3	2	1	0
Name	Channel Overtemperature Limit Value							
Reset	0	1	1	1	1	1	1	1

12.0 Temperature Sensor (TMS) (Continued)

12.4 TMS REGISTER BITMAP

12.4.1 TMS Control and Status Registers

Register		Bits							
Offset	Mnemonic	7	6	5	4	3	2	1	0
00h	TEVSTS	Reserved		Local Overtemp Event Status	Local $\overline{\text{ALERT}}$ Event Status	Remote 2 Overtemp Event Status	Remote 2 $\overline{\text{ALERT}}$ Event Status	Remote 1 Overtemp Event Status	Remote 1 $\overline{\text{ALERT}}$ Event Status
01h		Reserved							
02h	TEVSMI	Reserved		Local Overtemp Event to SMI Enable	Local $\overline{\text{ALERT}}$ Event to SMI Enable	Remote 2 Overtemp Event to SMI Enable	Remote 2 $\overline{\text{ALERT}}$ Event to SMI Enable	Remote 1 Overtemp Event to SMI Enable	Remote 1 $\overline{\text{ALERT}}$ Event to SMI Enable
03h		Reserved							
04h	TEVIRQ	Reserved		Local Overtemp Event to IRQ Enable	Local $\overline{\text{ALERT}}$ Event to IRQ Enable	Remote 2 Overtemp Event to IRQ Enable	Remote 2 $\overline{\text{ALERT}}$ Event to IRQ Enable	Remote 1 Overtemp Event to IRQ Enable	Remote 1 $\overline{\text{ALERT}}$ Event to IRQ Enable
05h-07h		Reserved							
08h	TMSCFG	Reserved						External VREF	Standby Mode
09h	TMSBS	Reserved				Bank Select			

12.4.2 TMS Channel Registers

Register		Bits							
Offset	Mnemonic	7	6	5	4	3	2	1	0
0Ah	TCHCFST	End of Conversion	Open	$\overline{\text{OTS}}$ Output Enable	$\overline{\text{ALERT}}$ Output Enable	Channel Overtemp Limit Exceeded	Channel Temp High Limit Exceeded	Channel Temp Low Limit Exceeded	Channel Enable
0Bh	RDCHT	Channel Temperature Value							
0Ch	CHTH	Channel Temperature High Limit Value							
0Dh	CHTL	Channel Temperature Low Limit Value							
0Eh	CHOTL	Channel Overtemperature Value							
0Fh		Reserved							

12.5 USAGE HINTS

12.5.1 Remote Diode Selection

Temperature accuracy depends on a good quality transistor, used as a diode-connected, small-signal transistor. Accuracy has been experimentally verified for the Motorola and other devices listed in Table 56. A temperature sensor can directly measure the die temperature of CPUs with on-board temperature-sensing diodes.

12.0 Temperature Sensor (TMS) (Continued)

The transistor must be a small-signal type with a relatively high forward voltage; otherwise, the A/D input voltage range can be violated. The forward voltage must be greater than 0.25V at 10 μ A at the highest expected temperature. The forward voltage must be less than 0.95V at 100 μ A at the lowest expected temperature. Large power transistors do not work. Also, ensure that the base resistance is less than 100 Ω . Tight specifications for forward-current gain (+50 to +150, for example) indicate devices with consistent VBE characteristics.

Thermal mass can seriously degrade the temperature sensor's effective accuracy. The use of smaller packages for remote sensors, such as SOT23s, improves the situation. The delay effect should be expected when measuring temperature using the internal diode.

Table 56. Remote Sensor Transistor Manufacturers

Manufacturer	Model
Central Semiconductor (USA)	CMPT3904
Motorola (USA)	MMBT3904
National Semiconductor (USA)	MMBT3904
Rohm Semiconductor (Japan)	SST3904
Samsung (Korea)	KST3904-TF
Siemens (Germany)	SMBT3904
Zetex (England)	FMMT3904CT-ND

12.5.2 ADC Noise Filtering

The ADC is an integrating type with inherently good noise rejection, especially of low-frequency signals such as power supply hum. Micropower operation places constraints on high frequency noise rejection; therefore, careful PC board layout and proper external noise filtering are required for high accuracy remote measurements in electrically noisy environments.

High frequency EMI is best filtered at DXP and DXN with an external 2200 pF capacitor. This value can be increased to about 3300pF (max), including cable capacitance. Capacitance higher than 3300 pF introduces errors, due to the rise time of the switched current source.

Nearly all noise sources tested cause the ADC measurements to be higher than the actual temperature, depending on the frequency and amplitude.

12.5.3 PC Board Layout

1. Place the temperature sensor as close as practical to the remote diode. In a noisy environment, such as a computer motherboard, this distance can be 4 in. to 8 in. (typical) or more, as long as the worst noise sources (such as CRTs, clock generators, memory buses, and ISA/PCI buses) are avoided.
2. Do not route the DXP DXN lines next to high inductance signals. Also, do not route the traces across a fast memory bus, which can easily introduce +30°C error, even with good filtering. Otherwise, most noise sources are fairly benign.
3. Route the DXP and DXN traces in parallel and in close proximity to each other, away from any high voltage traces such as +12VDC. Beware of leakage currents from PC board contamination; e.g., a 20M leakage path from DXP to ground causes about +1°C error.
4. Connect guard traces to GND on either side of the DXP DXN traces (Figure 45). With guard traces in place, routing near high-voltage traces is not a problem.
5. Route through as few vias and crossunders as possible to minimize copper/solder thermocouple effects.
6. When introducing a thermocouple, make sure that both the DXP and the DXN paths have matching thermocouples. In general, PC board-induced thermocouples are not a serious problem. A copper-solder thermocouple exhibits 3V/°C, and it takes about 200V of voltage error at DXP DXN to cause a +1°C measurement error. So, most parasitic thermocouple errors are swamped out.
7. Use wide traces. Narrow ones are more inductive and tend to pick up radiated noise. The 10 mil widths and spacings recommended in Figure 45 are not absolutely necessary (as they offer only a minor improvement in leakage and noise), but try to use them where practical.

12.0 Temperature Sensor (TMS) (Continued)

- Keep in mind that copper cannot be used as an EMI shield, and only ferrous materials such as steel work well. Placing a copper ground plane between the DXP-DXN traces and traces carrying high frequency noise signals does not help reduce EMI.

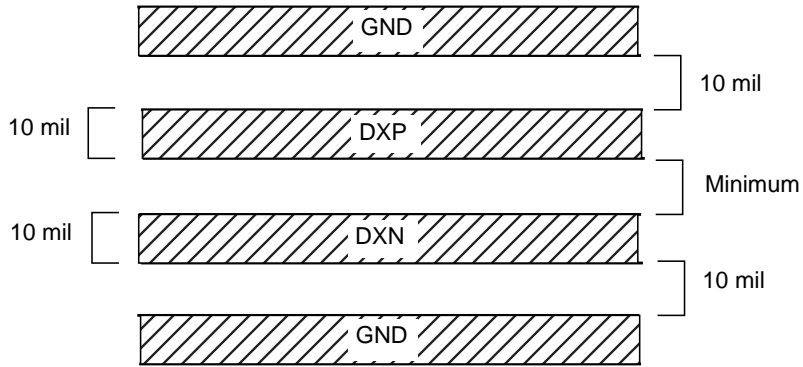

Figure 45. DXP/DXN PC Traces

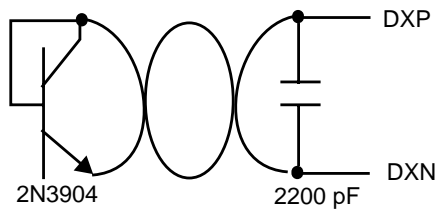

Figure 46. Typical Operating Circuit

12.0 Temperature Sensor (TMS) (Continued)

12.5.4 Twisted Pair and Shielded Cables

For remote sensor distances longer than 8 in., or in particularly noisy environments, a twisted pair is recommended. Its practical length is 6 feet to 12 feet (typical) before noise becomes a problem, as tested in a noisy electronics laboratory. For longer distances, the best solution is a shielded twisted pair like that used for audio microphones. Connect the twisted pair to DXP and DXN and the shield to GND, and leave the shield's remote end unterminated.

Excess capacitance at DX_ limits practical remote sensor distances. For very long cable runs, the cable's parasitic capacitance often provides noise filtering, so the 2200 pF capacitor can often be removed or reduced in value.

Cable resistance also affects remote sensor accuracy; 1Ω series resistance introduces about $+1/2^\circ\text{C}$ error.

13.0 Legacy Functional Blocks

This chapter briefly describes the following blocks that provide legacy device functions:

- Keyboard and Mouse Controller (KBC)
- Floppy Disk Controller (FDC)
- Parallel Port
- Serial Port 1 (SP1), UART Functionality for both Serial Port 1 and Serial Port 2
- Serial Port 2 (SP2), Infrared Functionality

The description of each Legacy block includes the sections listed below. For more information about legacy blocks, contact your National representative.

- General Description
- Register Map table(s)
- Bitmap table(s).

The register maps in this chapter use the following abbreviations for Type:

- R/W = Read/Write
- R = Read from a specific address returns the value of a specific register. Write to the same address is to a different register.
- W = Write
- RO = Read Only
- R/W1C = Read/Write 1 to Clear. Writing 1 to a bit clears it to 0. Writing 0 has no effect.

13.1 KEYBOARD AND MOUSE CONTROLLER (KBC)

13.1.1 General Description

The KBC is implemented physically as a single hardware module and houses two separate logical devices: a Mouse controller and a Keyboard controller.

The KBC is functionally equivalent to the industry standard 8042A Keyboard controller, which may serve as a detailed technical reference for the KBC.

13.1.2 KBC Register Map

Offset	Mnemonic	Register Name	Type
00h	DBBOUT	Read KBC Data	R
	DBBIN	Write KBC Data	W
04h	STATUS	Read Status	R
	DBBIN	Write KBC Command	W

13.1.3 KBC Bitmap Summary

Register		Bits							
Offset	Mnemonic	7	6	5	4	3	2	1	0
00h	DBBOUT	KBC Data Bits (For Read cycles)							
	DBBIN	KBC Data Bits (For Write cycles)							
04h	STATUS	General Purpose Flags				F1	F0	IBF	OBF
	DBBIN	KBC Command Bits (For Write cycles)							

13.0 Legacy Functional Blocks (Continued)

13.2 FLOPPY DISK CONTROLLER (FDC)

13.2.1 General Description

The generic FDC is a standard FDC with a digital data separator, and is DP8473 and N82077 software compatible.

The FDC is implemented in this device as follows:

- FM and MFM modes are supported. To select either mode, set bit 6 of the first command byte when writing to/reading from a diskette, where:
0 = FM mode
1 = MFM mode
- Automatic media sense is not supported (MSEN0-1 pins are not implemented).
- DRATE1 is not supported.
- A logic 1 is returned for all floating (TRI-STATE) FDC register bits upon LPC I/O read cycles.

13.2.2 FDC Register Map

Offset	Mnemonic	Register Name	Type
00h	SRA	Status A	RO
01h	SRB	Status B	RO
02h	DOR	Digital Output	R/W
03h	TDR	Tape Drive	R/W
04h	MSR	Main Status	R
	DSR	Data Rate Select	W
05h	FIFO	Data (FIFO)	R/W
06h	Reserved		
07h	DIR	Digital Input	R
	CCR	Configuration Control	W

13.0 Legacy Functional Blocks (Continued)

13.2.3 FDC Bitmap Summary

The FDC supports two system operation modes: PC-AT mode and PS/2 mode (MicroChannel systems). Unless specifically indicated otherwise, all fields in all registers are valid in both drive modes.

Register		Bits							
Offset	Mnemonic	7	6	5	4	3	2	1	0
00h	SRA ^{Note 1.}	IRQ Pending	Reserved	Step	$\overline{\text{TRK0}}$	Head Select	$\overline{\text{INDEX}}$	$\overline{\text{WP}}$	Head Direction
01h	SRB ^{Note 1.}	Reserved		Drive Select 0 Status	$\overline{\text{WDATA}}$	$\overline{\text{RDATA}}$	$\overline{\text{WGATE}}$	$\overline{\text{MTR1}}$	$\overline{\text{MTR0}}$
02h	DOR	Motor Enable 3	Motor Enable 2	Motor Enable 1	Motor Enable 0	DMAEN	Reset Controller	Drive Select	
03h	TDR	Reserved						Tape Drive Select 1,0	
	TDR ^{Note 2.}	Reserved		Drive ID Information		Logical Drive Exchange		Tape Drive Select 1,0	
04h	MSR	RQM	Data I/O Direction	Non-DMA Execution	Command in Progress	Drive 3 Busy	Drive 2 Busy	Drive 1 Busy	Drive 0 Busy
	DSR	Software Reset	Low Power	Reserved	Precompensation Delay Select			Data Transfer Rate Select	
05h	FIFO	Data Bits							
07h	DIR ^{Note 3.}	$\overline{\text{DSKCHG}}$	Reserved						
	DIR ^{Note 1.}	$\overline{\text{DSKCHG}}$	Reserved				DRATE 1,0 Status		High Density
07h	CCR	Reserved						DRATE1,0	

Note 1. Applicable only in PS/2 Mode

Note 2. Applicable only in Enhanced TDR Mode

Note 3. Applicable only in PC-AT Compatible Mode

13.0 Legacy Functional Blocks (Continued)

13.3 PARALLEL PORT

13.3.1 General Description

The Parallel Port supports all IEEE1284 standard communication modes: Compatibility (known also as Standard or SPP), Bidirectional (known also as PS/2), FIFO, EPP (known also as Mode 4) and ECP (with an optional Extended ECP mode).

13.3.2 Parallel Port Register Map

The Parallel Port functional block register maps are grouped according to first and second level offsets. EPP and second level offset registers are available only when base address is 8-byte aligned.

Table 57. Parallel Port Register Map for First Level Offset

First Level Offset	Mnemonic	Register Name	Modes (ECR Bits) 7 6 5	Type
000h	DATAR	PP Data	0 0 0 0 0 1	R/W
000h	AFIFO	ECP Address FIFO	0 1 1	W
001h	DSR	Status	All Modes	RO
002h	DCR	Control	All Modes	R/W
003h	ADDR	EPP Address	1 0 0	R/W
004h	DATA0	EPP Data Port 0	1 0 0	R/W
005h	DATA1	EPP Data Port 1	1 0 0	R/W
006h	DATA2	EPP Data Port 2	1 0 0	R/W
007h	DATA3	EPP Data Port 3	1 0 0	R/W
400h	CFIFO	PP Data FIFO	0 1 0	W
400h	DFIFO	ECP Data FIFO	0 1 1	R/W
400h	TFIFO	Test FIFO	1 1 0	R/W
400h	CNFGA	Configuration A	1 1 1	RO
401h	CNFGB	Configuration B	1 1 1	RO
402h	ECR	Extended Control	All Modes	R/W
403h	EIR	Extended Index	All Modes	R/W
404h	EDR	Extended Data	All Modes	R/W
405h	EAR	Extended Auxiliary Status	All Modes	R/W

Table 58. Parallel Port Register Map for Second Level Offset

Second Level Offset	Register Name	Type
00h	Control0	R/W
02h	Control2	R/W
04h	Control4	R/W
05h	PP Config0	R/W

13.0 Legacy Functional Blocks (Continued)

13.3.3 Parallel Port Bitmap Summary

The Parallel Port functional block bitmaps are grouped according to first and second level offsets.

Table 59. Parallel Port Bitmap Summary for First Level Offset

Register		Bits								
Offset	Mnemonic	7	6	5	4	3	2	1	0	
000h	DATAR	Data Bits								
	AFIFO	Address Bits								
001h	DSR	Printer Status	ACK Status	PE Status	SLCT Status	ERR Status	Reserved		EPP Time-out Status	
002h	DCR	Reserved		Direction Control	Interrupt Enable	PP Input Control	Printer Initialization Control	Automatic Line Feed Control	Data Strobe Control	
003h	ADDR	EPP Device or Register Selection Address Bits								
004h	DATA0	EPP Device or R/W Data								
005h	DATA1	EPP Device or R/W Data								
006h	DATA2	EPP Device or R/W Data								
007h	DATA3	EPP Device or R/W Data								
400h	CFIFO	Data Bits								
400h	DFIFO	Data Bits								
400h	TFIFO	Data Bits								
400h	CNFGA	Reserved				Bit 7 of PP Config0	Reserved			
401h	CNFGB	Reserved	Interrupt Request Value	Interrupt Select			Reserved	DMA Channel Select		
402h	ECR	ECP Mode Control			ECP Interrupt Mask	ECP DMA Enable	ECP Interrupt Service	FIFO Full	FIFO Empty	
403h	EIR	Reserved				Second Level Offset				
404h	EDR	Data Bits								
405h	EAR	FIFO Tag	Reserved							

13.0 Legacy Functional Blocks (Continued)

Table 60. Parallel Port Bitmap Summary for Second Level Offset

Register		Bits							
Second Level Offset	Mnemonic	7	6	5	4	3	2	1	0
00h	Control0	Reserved		DCR Register Live	Freeze Bit	Reserved			EPP Time-out Interrupt Mask
02h	Control2	SPP Compatibility	Channel Address Enable	Reserved	Revision 1.7 or 1.9 Select	Reserved			
04h	Control4	Reserved	PP DMA Request Inactive Time			Reserved	PP DMA Request Active Time		
05h	PP Config0	Bit 3 of CNFGA	Demand DMA Enable	ECP IRQ Channel Number			PE Internal Pull-up or Pull-down	ECP DMA Channel Number	

13.0 Legacy Functional Blocks (Continued)

13.4 UART FUNCTIONALITY (SP1 AND SP2)

13.4.1 General Description

Both SP1 and SP2 provide UART functionality. The generic SP1 and SP2 support serial data communication with remote peripheral device or modem using a wired interface. The functional blocks can function as a standard 16450, 16550, or as an Extended UART.

13.4.2 UART Mode Register Bank Overview

Four register banks, each containing eight registers, control UART operation. All registers use the same 8-byte address space to indicate offsets 00h through 07h. The BSR register selects the active bank and is common to all banks. See Figure 47.

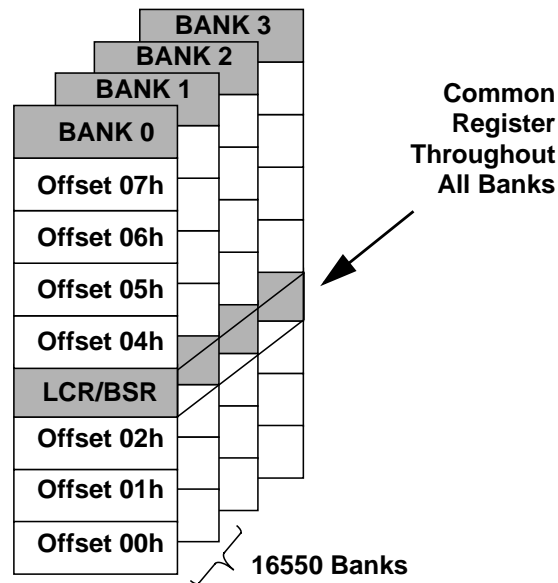

Figure 47. UART Mode Register Bank Architecture

13.0 Legacy Functional Blocks (Continued)

13.4.3 SP1 and SP2 Register Maps for UART Functionality

Table 61. Bank 0 Register Map

Offset	Mnemonic	Register Name	Type
00h	RXD	Receiver Data Port	RO
00h	TXD	Transmitter Data Port	W
01h	IER	Interrupt Enable	R/W
02h	EIR	Event Identification (Read Cycles)	RO
	FCR	FIFO Control (Write Cycles)	W
03h	LCR ^{Note 1.}	Line Control	R/W
	BSR ^{Note 1.}	Bank Select	
04h	MCR	Modem/Mode Control	R/W
05h	LSR	Link Status	RO
06h	MSR	Modem Status	RO
07h	SPR/ASCR	Scratchpad/Auxiliary Status and Control	R/W

Note 1. When bit 7 of this Register is set to 1, bits 6-0 of BSR select the bank, as shown in Table 62.

Table 62. Bank Selection Encoding

BSR Bits								Bank Selected	Functionality
7	6	5	4	3	2	1	0		
0	x	x	x	x	x	x	x	0	UART + IR (SP1 + SP2)
1	0	x	x	x	x	x	x	1	
1	1	x	x	x	x	1	x	1	
1	1	x	x	x	x	x	1	1	
1	1	1	0	0	0	0	0	2	
1	1	1	0	0	1	0	0	3	
1	1	1	0	1	0	0	0	4	IR Only (SP2)
1	1	1	0	1	1	0	0	5	
1	1	1	1	0	0	0	0	6	
1	1	1	1	0	1	0	0	7	

Table 63. Bank 1 Register Map

Offset	Mnemonic	Register Name	Type
00h	LBGD(L)	Legacy Baud Generator Divisor Port (Low Byte)	R/W
01h	LBGD(H)	Legacy Baud Generator Divisor Port (High Byte)	R/W
02h	Reserved		
03h	LCR/BSR	Line Control/Bank Select	R/W
04h - 07h	Reserved		

13.0 Legacy Functional Blocks (Continued)

Table 64. Bank 2 Register Map

Offset	Mnemonic	Register Name	Type
00h	BGD(L)	Baud Generator Divisor Port (Low Byte)	R/W
01h	BGD(H)	Baud Generator Divisor Port (High Byte)	R/W
02h	EXCR1	Extended Control1	R/W
03h	LCR/BSR	Line Control/Bank Select	R/W
04h	EXCR2	Extended Control 2	R/W
05h	Reserved		
06h	TXFLV	TX_FIFO Level	R/W
07h	RXFLV	RX_FIFO Level	R/W

Table 65. Bank 3 Register Map

Offset	Mnemonic	Register Name	Type
00h	MRID	Module Revision ID	RO
01h	SH_LCR	Shadow of LCR (Read Only)	RO
02h	SH_FCR	Shadow of FIFO Control (Read Only)	RO
03h	LCR/BSR	Line Control/Bank Select	R/W
04h-07h	Reserved		

13.0 Legacy Functional Blocks (Continued)

13.4.4 SP1 and SP2 Bitmap Summary for UART Functionality

Table 66. Bank 0 Bitmap

Register		Bits							
Offset	Mnemonic	7	6	5	4	3	2	1	0
00h	RXD	Receiver Data Bits							
	TXD	Transmitter Data Bits							
01h	IER ^{Note 1.}	Reserved				MS_IE	LS_IE	TXLDL_IE	RXHDL_IE
	IER ^{Note 2.}	Reserved		TXEMP_IE	Reserved Note 3./ DMA_IE Note 4.	MS_IE	LS_IE	TXLDL_IE	RXHDL_IE
02h	EIR ^{Note 1.}	FEN1	FEN0	Reserved		RXFT	IPR1	IPR0	IPF
	EIR ^{Note 2.}	Reserved		TXEMP_EV	Reserved Note 3./ DMA_EV Note 4.	MS_EV	LS_EV or TXHLT_EV	TXLDL_EV	RXHDL_EV
	FCR	RXFTH1	RXFTH0	TXFTH1	TXFTH0	Reserved	TXSR	RXSR	FIFO_EN
03h	LCR ^{Note 5.}	BKSE	SBRK	STKP	EPS	PEN	STB	WLS1	WLS0
	BSR ^{Note 5.}	BKSE	Bank Select						
04h	MCR ^{Note 1.}	Reserved			LOOP	ISEN or DCDLP	RILP	RTS	DTR
	MCR ^{Note 2.}	Reserved				TX_DFR	Reserved	RTS	DTR
05h	LSR	ER_INF	TXEMP	TXRDY	BRK	FE	PE	OE	RXDA
06h	MSR	DCD	RI	DSR	CTS	DDCD	TERI	DDSR	DCTS
07h	SPR ^{Note 1.}	Scratch Data							
	ASCR Note 2.	Reserved	TXUR ^{Note 4.}	RXACT Note 4.	RXWDG Note 4.	Reserved	S_OET Note 4.	Reserved	RXF_TOUT

Note 1. Non-Extended Mode

Note 2. Extended Mode

Note 3. In SP1 only

Note 4. In SP2 only

Note 5. When bit 7 of this register is set to 1, bits 6-0 of BSR select the bank, as shown in Table 62.

13.0 Legacy Functional Blocks (Continued)

Table 67. Bank 1 Bitmap

Register		Bits							
Offset	Mnemonic	7	6	5	4	3	2	1	0
00h	LBGD(L)	Legacy Baud Generator Divisor (Least Significant Bits)							
01h	LBGD(H)	Legacy Baud Generator Divisor (Most Significant Bits)							
02h		Reserved							
03h	LCR/BSR	Same as Bank 0							
04h-07h		Reserved							

Table 68. Bank 2 Bitmap

Register		Bits							
Offset	Mnemonic	7	6	5	4	3	2	1	0
00h	BGD(L)	Baud Generator Divisor Low (Least Significant Bits)							
01h	BGD(H)	Baud Generator Divisor High (Most Significant Bits)							
02h	EXCR1	BTEST	Reserved	ETDLBK	LOOP	Reserved		EXT_SL	
03h	LCR/BSR	Same as Bank 0							
04h	EXCR2	LOCK	Reserved	PRESL1	PRESL0	Reserved			
05h	Reserved								
06h	TXFLV	Reserved			TFL4	TFL3	TFL2	TFL1	TFL0
07h	RXFLV	Reserved			RFL4	RFL3	RFL2	RFL1	RFL0

Table 69. Bank 3 Bitmap

Register		Bits							
Offset	Mnemonic	7	6	5	4	3	2	1	0
00h	MRID	Module ID (MID 7-4)				Revision ID(RID 3-0)			
01h	SH_LCR	BKSE	SBRK	STKP	EPS	PEN	STB	WLS1	WLS0
02h	SH_FCR	RXFTH1	RXFTH0	TXFHT1	TXFTH0	Reserved	TXSR	RXSR	FIFO_EN
03h	LCR/BSR	Same as Bank 0							
04h-07h		Reserved							

13.0 Legacy Functional Blocks (Continued)

13.5 IR FUNCTIONALITY (SP2)

13.5.1 General Description

This section describes the IR support registers of Serial Port 2 (SP2). The UART support registers for both SP1 and SP2 are described in Section 13.4.

The IR functional block provides advanced, versatile serial communications features with IR capabilities.

SP2 supports also two DMA channels; the functional block can use either one or both of them. One channel is required for IR-based applications, since IR communication works in half duplex fashion. Two channels would normally be needed to handle high-speed full duplex UART based applications.

13.5.2 IR Mode Register Bank Overview

Eight register banks, each containing eight registers, control SP2 operation. Banks 0-3 are used to control both UART and IR modes of operation; banks 4-7 are used to control and configure the IR modes of operation only. All registers use the same 8-byte address space to indicate offsets 00h through 07h. The BSR register selects the active bank and is common to all banks. See Figure 48.

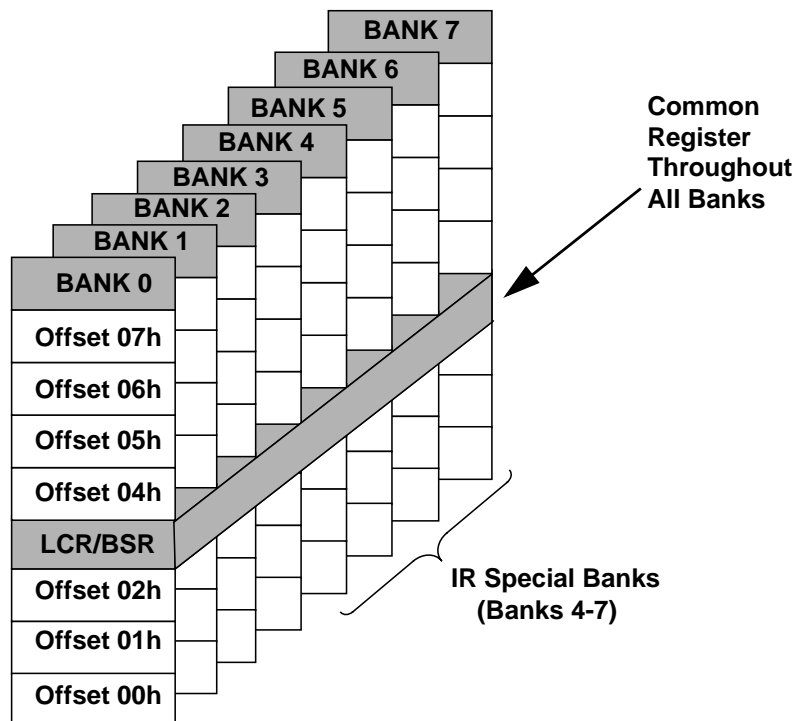

Figure 48. SP2 Register Bank Architecture

13.0 Legacy Functional Blocks (Continued)

13.5.3 SP2 Register Map for IR Functionality

Table 70. Bank 4 Register Map

Offset	Mnemonic	Register Name	Type
00h-01h	Reserved		
02h	IRCR1	IR Control 1	R/W
03h	LCR/BSR	Line Control/Bank Select	R/W
04h - 07h	Reserved		

Table 71. Bank 5 Register Map

Offset	Mnemonic	Register Name	Type
00h-02h	Reserved		
03h	LCR/BSR	Line Control/Bank Select	R/W
04h	IRCR2	IR Control 2	R/W
05h - 07h	Reserved		

Table 72. Bank 6 Register Map

Offset	Mnemonic	Register Name	Type
00h	IRCR3	IR Control 3	R/W
01h	Reserved		
02h	SIR_PW	SIR Pulse Width Control (≤ 115 Kbps)	R/W
03h	LCR/BSR	Line Control/Bank Select	R/W
04h-07h	Reserved		

Table 73. Bank 7 Register Map

Offset	Mnemonic	Register Name	Type
00h	IRRXDC	IR Receiver Demodulator Control	RO
01h	IRTXMC	IR Transmitter Modulator Control	RO
02h	RCCFG	CEIR Configuration	RO
03h	LCR/BSR	Line Control/Bank Select	R/W
04h	IRCFG1	IR Interface Configuration 1	R/W
05h	Reserved		
06h	IRCFG3	IR Interface Configuration 3	R/W
07h	IRCFG4	IR Interface Configuration 4	R/W

13.0 Legacy Functional Blocks (Continued)

13.5.4 SP2 Bitmap Summary for IR Functionality

Table 74. Bank 4 Bitmap

Register		Bits								
Offset	Mnemonic	7	6	5	4	3	2	1	0	
00h-01h		Reserved								
02h	EIR	Reserved				IR_SL1	IR_SL0	Reserved		
03h	LCR/BSR	Same as Bank 0								
04h-07h		Reserved								

Table 75. Bank 5 Bitmap

Register		Bits							
Offset	Mnemonic	7	6	5	4	3	2	1	0
00h-02h		Reserved							
03h	LCR/BSR	Same as Bank 0							
04h	IRCR2	Reserved			AUX_IRRX	Reserved		IRMSSL	IR_FDPLX
05h-07h		Reserved							

Table 76. Bank 6 Bitmap

Register		Bits							
Offset	Mnemonic	7	6	5	4	3	2	1	0
00h	IRCR3	SHDM_DS	SHMD_DS	Reserved					
01h		Reserved							
02h	SIR_PW	Reserved				SPW (3-0)			
03h	LCR/BSR	Same as Bank 0							
04h-07h		Reserved							

13.0 Legacy Functional Blocks (Continued)

Table 77. Bank 7 Bitmap

Register		Bits							
Offset	Mnemonic	7	6	5	4	3	2	1	0
00h	IRRXDC	DBW (2-0)			DFR (4-0)				
01h	IRTXMC	MCPW (2-0)			MCFR (4-0)				
02h	RCCFG	R_LEN	T_OV	RXHSC	RCDM_DS	Reserved	TXHSC	RC_MND1	RC_MMD0
03h	LCR/BSR	Same as Bank 0							
04h	IRCFG1	STRV_MS	SIRC (2-0)			IRID3	IRIC (2-0)		
05h	Reserved								
06h	IRCFG3	Reserved	RCH (2-0)			Reserved	RCLC (2-0)		
07h	IRCFG4	AMCFG	Reserved	IRSL0_DS	RXINV	IRSL21_DS	Reserved		

14.0 Device Characteristics

14.1 GENERAL DC ELECTRICAL CHARACTERISTICS

14.1.1 Recommended Operating Conditions

Symbol	Parameter	Min	Typ	Max	Unit
V_{DD}	Analog Supply Voltage (only one)	3.0	3.3	3.6	V
V_{DD}	Supply Voltage	3.0	3.3	3.6	V
V_{SB}	Standby Voltage	3.0	3.3	3.6	V
V_{BAT}	Battery Backup Supply Voltage	2.4	3.0	3.6	V
T_A	Operating Temperature	0		+70	°C

14.1.2 Absolute Maximum Ratings

Absolute maximum ratings are values beyond which damage to the device may occur. Unless otherwise specified, all voltages are relative to ground.

Symbol	Parameter	Conditions	Min	Max	Unit
V_{DD}	Analog Supply Voltage		-0.5	TBD	
V_{DD}	Supply Voltage		-0.5	+6.5	V
V_I	Input Voltage		-0.5	$V_{DD} + 0.5$	V
V_O	Output Voltage		-0.5	$V_{DD} + 0.5$	V
T_{STG}	Storage Temperature		-65	+165	°C
P_D	Power Dissipation			1	W
T_L	Lead Temperature Soldering (10 s)			+260	°C
	ESD Tolerance	$C_{ZAP} = 100 \text{ pF}$ $R_{ZAP} = 1.5 \text{ K}\Omega$ ^{Note 1.}	2000		V

Note 1. Value based on test complying with RAI-5-048-RA human body model ESD testing.

14.1.3 Capacitance

Symbol	Parameter	Min	Typ	Max	Unit
C_{IN}	Input Pin Capacitance		5	7	pF
C_{IN1}	Clock Input Capacitance	5	8	12	pF
C_{IO}	I/O Pin Capacitance		10	12	pF
C_O	Output Pin Capacitance		6	8	pF

$T_A = 25^\circ\text{C}$, $f = 1 \text{ MHz}$

14.0 Device Characteristics (Continued)

14.1.4 Power Consumption under Recommended Operating Conditions

Symbol	Parameter	Conditions	Typ	Max	Unit
I_{CC}	V_{DD} Average Main Supply Current	$V_{IL} = 0.5\text{ V}$, $V_{IH} = 2.4\text{ V}$ No Load	32	50	mA
I_{CCLP}	V_{DD} Quiescent Main Supply Current in Low Power Mode	$V_{IL} = V_{SS}$, $V_{IH} = V_{DD}$ No Load	1.3	1.7	mA
I_{ASB}	AV_{DD} Average Main Supply Current	TBD		TBD	mA
I_{SB}	V_{SB} Average Main Supply Current	$V_{IL} = 0.5\text{ V}$, $V_{IH} = 2.4\text{ V}$ No Load		15	mA
I_{SBLP}	V_{SB} Quiescent Main Supply Current in Low Power Mode	$V_{IL} = V_{SS}$, $V_{IH} = V_{SB}$ No Load		3	mA
I_{BAT}	V_{BAT} Battery Supply Current	V_{DD} , $V_{SB} = 0\text{ V}$, $V_{BAT} = 3\text{ V}$		250	nA

14.2 DC CHARACTERISTICS OF PINS, BY I/O BUFFER TYPES

The following tables summarize the DC characteristics of all device pins described in the *Signal/Pin Connection and Description* chapter. The characteristics describe the general I/O buffer types defined in Table 1. For exceptions, refer to Section 14.2.15. The DC characteristics of the system interface meet the PCI2.1 3.3V DC signaling.

14.2.1 Input, CMOS Compatible

Symbol: I_{NC}

Symbol	Parameter	Conditions	Min	Max	Unit
V_{IH}	Input High Voltage		$0.7 V_{DD}$	$5.5^{\text{Note 1}}$	V
V_{IL}	Input Low Voltage		$-0.5^{\text{Note 1}}$	$0.3 V_{DD}$	V
I_{IL}	Input Leakage Current	$V_{IN} = V_{DD}$		50	nA
		$V_{IN} = V_{SS}$		-50	nA

Note 1. Not tested. Guaranteed by design.

14.2.2 Input, PCI 3.3V

Symbol: I_{NPCI}

Symbol	Parameter	Conditions	Min	Max	Unit
V_{IH}	Input High Voltage		$0.5V_{DD}$	$V_{DD} + 0.5$	V
V_{IL}	Input Low Voltage		-0.5	$0.3V_{DD}$	V
$I_{IL}^{\text{Note 1}}$	Input Leakage Current	$0 < V_{in} < V_{DD}$		± 10	μA

Note 1. Input leakage currents include hi-Z output leakage for all bidirectional buffers with TRI-STATE outputs.

14.0 Device Characteristics (Continued)

14.2.3 Input, SMBus Compatible

Symbol: I_{NSM}

Symbol	Parameter	Conditions	Min	Max	Unit
V_{IH}	Input High Voltage		1.4	5.5 ^{Note 1.}	V
V_{IL}	Input Low Voltage		-0.5 ^{Note 1.}	0.8	V
I_{IL}	Input Leakage Current	$V_{IN} = V_{DD}$		10	μA
		$V_{IN} = V_{SS}$		-10	μA

Note 1. Not tested. Guaranteed by design.

14.2.4 Input, Strap Pin

Symbol: I_{NSTRP}

Symbol	Parameter	Conditions	Min	Max	Unit
V_{IH}	Input High Voltage		0.6 V_{DD} ^{Note 1.}	5.5 ^{Note 1.}	V
I_{IL}	Input Leakage Current	During Reset: $V_{IN} = V_{DD}$		150	μA
		$V_{IN} = V_{SS}$		-10	μA

Note 1. Not tested. Guaranteed by design.

14.2.5 Input, TTL Compatible

Symbol: I_{NT}

Symbol	Parameter	Conditions	Min	Max	Unit
V_{IH}	Input High Voltage		2.0	5.5 ^{Note 1.}	V
V_{IL}	Input Low Voltage		-0.5 ^{Note 1.}	0.8	V
I_{IL}	Input Leakage Current	$V_{IN} = V_{DD}$		10	μA
		$V_{IN} = V_{SS}$		-10	μA

Note 1. Not tested. Guaranteed by design.

14.2.6 Input, TTL Compatible with Schmitt Trigger

Symbol: I_{NTS}

Symbol	Parameter	Conditions	Min	Max	Unit
V_{IH}	Input High Voltage		2.0	5.5 ^{Note 1.}	V
V_{IL}	Input Low Voltage		-0.5 ^{Note 1.}	0.8	V
I_{IL}	Input Leakage Current	$V_{IN} = V_{DD}$		10	μA
		$V_{IN} = V_{SS}$		-10	μA
V_H	Input Hysteresis		250		mV

Note 1. Not tested. Guaranteed by design.

14.0 Device Characteristics (Continued)

14.2.7 Output, PCI 3.3V

Symbol: O_{PCI}

Symbol	Parameter	Conditions	Min	Max	Unit
V_{OH}	Output High Voltage	$I_{out} = -500 \mu A$	$0.9V_{DD}$		V
V_{OL}	Output Low Voltage	$I_{out} = 1500 \mu A$		$0.1 V_{DD}$	V

14.2.8 Output, Totem-Pole Buffer

Symbol: $O_{p/n}$

Output, Totem-Pole buffer that is capable of sourcing p mA and sinking n mA

Symbol	Parameter	Conditions	Min	Max	Unit
V_{OH}	Output High Voltage	$I_{OH} = -p$ mA	2.4		V
V_{OL}	Output Low Voltage	$I_{OL} = n$ mA		0.4	V

14.2.9 Output, Open-Drain Buffer

Symbol: OD_n

Output, Open-Drain output buffer, capable of sinking n mA. Output from these signals is open-drain and cannot be forced high.

Symbol	Parameter	Conditions	Min	Max	Unit
V_{OL}	Output Low Voltage	$I_{OL} = n$ mA		0.4	V

14.2.10 Input, Analog

Symbol: IN_{AN1}

Input, analog to VLM.

Symbol	Parameter	Conditions ^{Note 1.}	Min	Typ	Max	Unit
I_{AL}	Analog Input Leakage Current				± 1	μA
R_{AIN}	Analog Input Resistance ^{Note 2.}				250	Ω
C_{AIN}	Analog Input Capacitance				15	pF

Note 1. All parameters specified for $0^\circ C \leq T_A \leq 70^\circ C$.

$AV_{CC} = 3.3V \pm 10\%$, unless otherwise specified and $V_{REF} = 1.235$ or AV_{DD} .

Note 2. The resistance between the device input and the internal analog input capacitance.

14.2.11 Input, Analog

Symbol: IN_{AN2}

Input, analog to reference voltage.

Symbol	Parameter	Conditions ^{Note 1.}	Min	Typ	Max	Unit
V_{REFE}	External Reference Voltage		TBD	1.235	TBD	V
R_{VREFE}	V_{REF} Input DC resistance ^{Note 2.}		5		36	K Ω

Note 1. All parameters specified for $0^\circ C \leq T_A \leq 70^\circ C$.

$AV_{CC} = 3.3V \pm 10\%$, unless otherwise specified and $V_{REF} = 1.235$ or AV_{DD} .

Note 2. Valid only for external V_{REF} ; value changes during the conversion.

14.0 Device Characteristics (Continued)

14.2.12 Input, Analog

Symbol: $I_{N_{AN3}}$

Input, analog to TMS.

Symbol	Parameter	Conditions	Min	Typ	Max	Unit
V_{DN}	D- Source Voltage			0.7		V

14.2.13 Output, Analog

Symbol: O_{AN1}

Output, analog to reference voltage.

Symbol	Parameter	Conditions	Min	Typ	Max	Unit
V_{REFE}	External Reference Voltage		1.233	1.235	1.237	V
R_{VREFE}	V_{REF} Input DC resistance ^{Note 1.}		5		36	K Ω

Note 1. Valid only for external V_{REF} ; value changes during the conversion.

14.2.14 Output, Analog

Symbol: O_{AN2}

Output, analog to TMS.

Symbol	Parameter	Conditions	Min	Typ	Max	Unit
I_{DPH}	Diode Source Current	D+ = D- + 0.65V; High Level	80		120	μ A
I_{DPL}		Low Level	8		12	μ A

14.2.15 Exceptions

- All pins are back-drive protected, except for the output pins with PCI Buffer Type.
- The following pins have a static pull-up resistor and therefore may have input leakage current (when $V_{IN} = V_{SS}$) of about (-)160 μ A: \overline{ACK} , $\overline{AFD_DSTRB}$, \overline{ERR} , GPIO40-47, GPIO30-34, GPIO20-27, GPIO16-17, GPIO10-14, GPIO00-07, \overline{INIT} , P12, P16, P17, PE, $\overline{SLIN_ASTRB}$, $\overline{STB_WRITE}$
- The following pins have a static pull-down resistor and therefore may have input leakage current (when $V_{IN} = V_{DD}$) of about 130 μ A: $\overline{BUSY_WAIT}$, PE, SLCT
- Output from SLCT, $\overline{BUSY_WAIT}$ (and PE if bit 2 of PP Config0 Register is "0") is open-drain in all SPP modes, except in SPP Compatible mode when the setup mode is ECP-based FIFO and bit 4 of the Control2 parallel port register is 1. Otherwise, output from these signals is level 2. External 4.7 K Ω pull-up resistors should be used.
- Output from \overline{ACK} , \overline{ERR} (and PE if bit 2 of PP Config0 Register is set to 1) is open-drain in all SPP modes, except in SPP Compatible mode when the setup mode is ECP-based FIFO and bit 4 of the Control2 parallel port register is set to 1. Otherwise, output from these signals is level 2. External 4.7 K Ω pull-up resistors should be used.
- Output from \overline{STB} , \overline{AFD} , \overline{INIT} , \overline{SLIN} is open-drain in all SPP modes, except in SPP Compatible mode when the setup mode is ECP-based (FIFO). Otherwise, output from these signals is level 2. External 4.7 K Ω pull-up resistors should be used.
- Output from PD7-0 is open-drain in all SPP modes, except in SPP Compatible mode when the setup mode is ECP-based (FIFO) and bit 4 of the Control2 parallel port register is 1. Otherwise, output from these signals is Level 2. External 4.7 K Ω pull-up resistors should be used.
- I_{OH} is valid for a GPIO pin only when it is not configured as open-drain.
- P12, P16 and P17 are driven high for about 100 ns after a low-to-high transition, during which it is capable of sourcing 2 mA.

14.0 Device Characteristics (Continued)

14.3 INTERNAL RESISTORS

14.3.1 Pull-Up Resistor

Symbol: PU_{nn} .

Symbol	Parameter	Conditions	Typical	Min	Max	Unit
R_{PU}	Pull-up equivalent resistance	$V_{DD} = 3.3V$	nn	$nn-30\%$	$nn+30\%$	$K\Omega$

14.3.2 Pull-Down Resistor

Symbol: PD_{nn} .

Symbol	Parameter	Conditions	Typical	Min	Max	Unit
R_{PD}	Pull-down equivalent resistance	$V_{DD} = 3.3V$	nn	$nn-30\%$	$nn+30\%$	$K\Omega$

14.4 ANALOG CHARACTERISTICS

14.4.1 VLM

Symbol	Parameter	Conditions ^{Note 1.}	Min	Typ	Max	Unit
V_{RES}	Resolution			8		bit
V_{INL}	Integral (non-linearity) Error ^{Note 2.}			± 2.0	± 3.0	LSB Note 3.
V_{IREF}	Internal Reference Voltage		± 2.203	1.211	± 2.219	V
V_{DNL}	Differential (non-linearity) Error ^{Note 4.}				0.5	LSB Note 3
V_{OER}	Offset Error				± 2.0	LSB Note 3
V_{GER}	Gain Error				± 2.0	LSB Note 3
V_{IN}	Input Voltage Range		0		$2.45 \cdot V_{REF}$	V
V_{REF}	Reference Voltage Input ^{Note 5.}			1.211		V
t_{ACT}	VLM Activation Time ^{Note 6.}				100	μs

Note 1. All parameters specified for $0^\circ C \leq T_A \leq 70^\circ C$.

$AV_{CC} = 3.3V \pm 10\%$ unless otherwise specified and $V_{REF} = 1.211$.

Note 2. The maximum difference between the ideal straight line reference and the actual conversion curves. This parameter is only partially tested in production, and is guaranteed by characterization.

Note 3. The parameter value XX LSB means XX times the value of one least significant bit, where V_{REF} is the typical V_{REF} .

Note 4. The maximum difference between an ideal step size of 1 LSB and any actual step size. This parameter is only partially tested in production, and is guaranteed by characterization.

Note 5. When using input with value other than specified, the V_{REF} used by the VLM changes based on the actual input value.

Note 6. Time from when the VLMCFG register Standby Mode Enable bit = 0 until valid conversions are possible.

14.4.2 TMS

14.0 Device Characteristics (Continued)

Symbol	Parameter	Conditions ^{Note 1.}	Min	Typ	Max	Unit
T _{RAC1}	Accuracy Using Remote Diode	T _A = -40°C to +125°C	-9		+8	C
T _{RAC2}		T _A = +40°C to +100°C	-5		+5	C
T _{LAC1}	Accuracy Using Local Diode	T _A = -40°C to +125°C	-5		+5	C
T _{LAC2}		T _A = +40°C to +100°C	-2		+2	C
T _{RESB}	Resolution			8		bits
T _{RESC}				1		°C
V _{REF}	Reference Voltage Input ^{Note 2.}			1.211		V
t _{CONV}	Temperature Conversion Time (per channel)			100		mS

Note 1. All parameters specified for 0° C ≤ T_A ≤ 70° C.

A_{VCC} = 3.3V ± 10% unless otherwise specified and V_{REF} = 1.211.

Note 2. When using input with value other than specified, temperature reading accuracy is affected.

14.0 Device Characteristics (Continued)

14.5 AC ELECTRICAL CHARACTERISTICS

14.5.1 AC Test Conditions

Load Circuit (Notes 1, 2, 3)

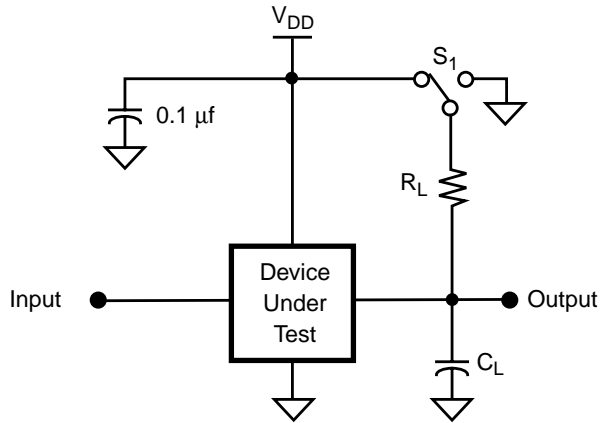

AC Testing Input, Output Waveform

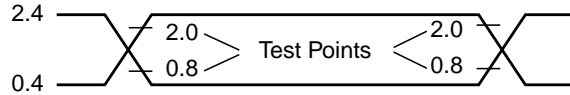

Figure 49. AC Test Conditions, $T_A = 0\text{ }^{\circ}\text{C}$ to $70\text{ }^{\circ}\text{C}$, $V_{DD} = 5.0\text{ V} \pm 10\%$

Notes:

- $C_L = 100\text{ pF}$ for all output except O_{PCI} , and $C_L = 50\text{ pF}$ for outputs of type O_{PCI} , this includes jig and scope capacitance.
- $S_1 = \text{Open}$ for push-pull output pins.
 $S_1 = V_{DD}$ for high impedance to active low and active low to high impedance measurements.
 $S_1 = \text{GND}$ for high impedance to active high and active high to high impedance measurements.
 $R_L = 1.0\text{ k}\Omega$ for μP interface pins.
- For the FDC open-drive interface pins, $S_1 = V_{DD}$ and $R_L = 150\Omega$.

14.5.2 Clock Timing

Symbol	Parameter	48 MHz		Unit
		Min	Max	
t_{CH}	Clock High Pulse Width ^{Note 1.}	8.4		ns
t_{CL}	Clock Low Pulse Width ^{Note 1.}	8.4		ns
t_{CP}	Clock Period ^{Note 1.}	20	21.5	ns

Note 1. Not tested. Guaranteed by design.

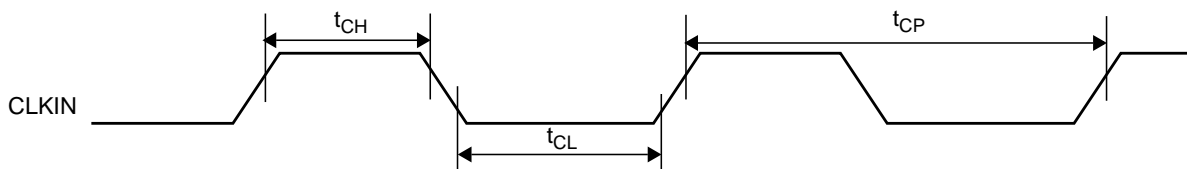

14.0 Device Characteristics (Continued)

14.5.3 LCLK and $\overline{\text{LRESET}}$

Symbol	Parameter	Min	Max	Units
t_{CYC} Note 1.	LCLK Cycle Time	30		ns
t_{HIGH}	LCLK High Time	11		ns
t_{LOW}	LCLK Low Time	11		ns
-	LCLK Slew Rate ^{Note 2.}	1	4	V/ns
-	$\overline{\text{LRESET}}$ Slew Rate ^{Note 3.}	50		mV/ns

Note 1. The PCI may have any clock frequency between nominal DC and 33 MHz. Device operational parameters at frequencies under 16 MHz may be guaranteed by design rather than by testing. The clock frequency may be changed at any time during the operation of the system as long as the clock edges remain "clean" (monotonic) and the minimum cycle and high and low times are not violated. The clock may only be stopped in a low state.

Note 2. Rise and fall times are specified in terms of the edge rate measured in V/ns. This slew rate must be met across the minimum peak-to-peak portion of the clock wavering as shown below.

Note 3. The minimum $\overline{\text{LRESET}}$ slew rate applies only to the rising (de-assertion) edge of the reset signal, and ensures that system noise cannot render an otherwise a monotonic signal to appear to bounce in the switching range.

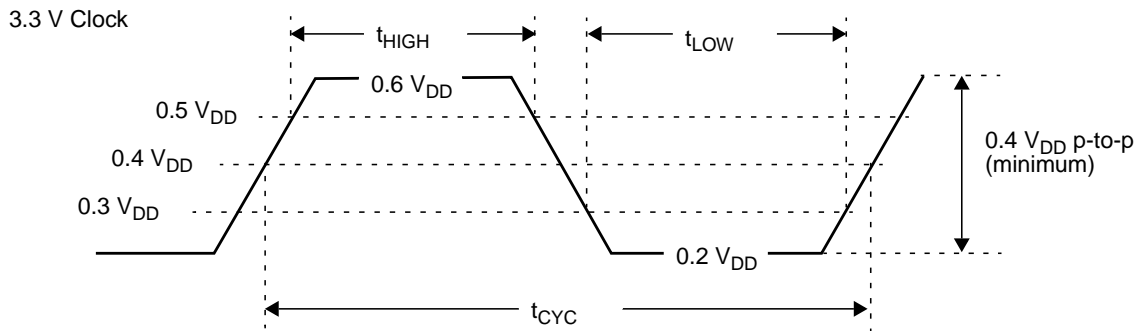

14.0 Device Characteristics (Continued)

14.5.4 LPC and SERIRQ Signals

Symbol	Figure	Description	Reference Conditions	Min	Max	Unit
t_{VAL}	Output	Output Valid Delay	After RE CLK		11	ns
t_{ON}	Output	Float to Active Delay	After RE CLK	2		ns
t_{OFF}	Output	Active to Float Delay	After RE CLK		28	ns
t_{SU}	Input	Input Setup Time	Before RE CLK	7		ns
t_{HI}	Input	Input Hold Time	After RE CLK	0		ns

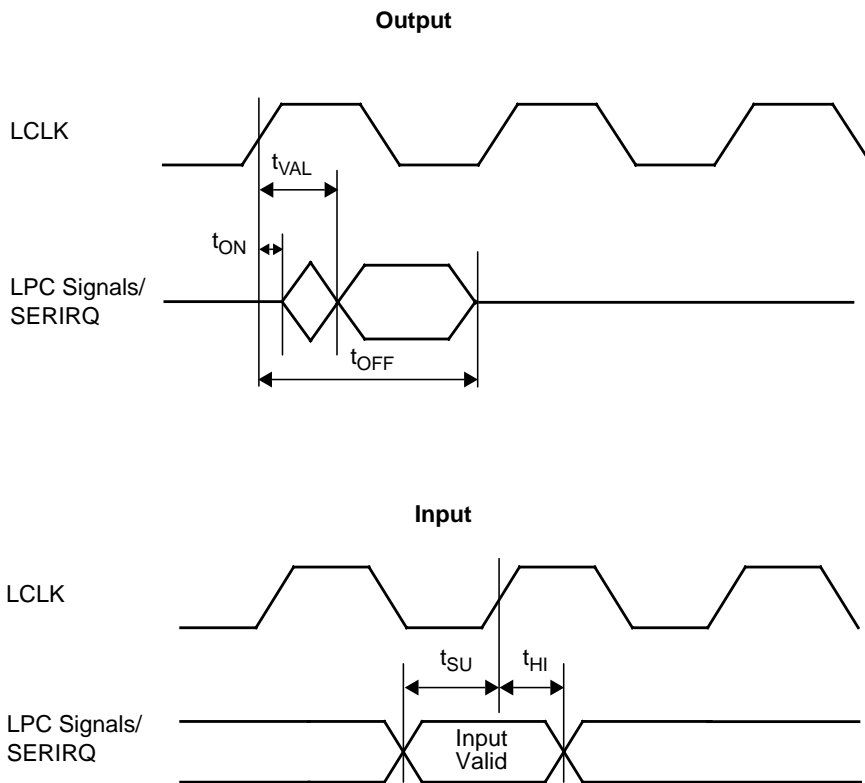

14.0 Device Characteristics (Continued)

14.5.5 Serial Port, Sharp-IR, SIR and Consumer Remote Control Timing

Symbol	Parameter	Conditions	Min	Max	Unit
t_{BT}	Single Bit Time in Serial Port and Sharp-IR	Transmitter	$t_{BTN} - 25$ Note 1.	$t_{BTN} + 25$	ns
		Receiver	$t_{BTN} - 2\%$	$t_{BTN} + 2\%$	ns
t_{CMW}	Modulation Signal Pulse Width in Sharp-IR and Consumer Remote Control	Transmitter	$t_{CWN} - 25$ Note 2.	$t_{CWN} + 25$	ns
		Receiver	500		ns
t_{CMP}	Modulation Signal Period in Sharp-IR and Consumer Remote Control	Transmitter	$t_{CPN} - 25$ Note 3.	$t_{CPN} + 25$	ns
		Receiver	t_{MMIN} Note 4.	t_{MMAX} Note 4.	ns
t_{SPW}	SIR Signal Pulse Width	Transmitter, Variable	$(\sqrt[3]{16}) \times t_{BTN} - 15$ Note 1.	$(\sqrt[3]{16}) \times t_{BTN} + 15$ Note 1.	ns
		Transmitter, Fixed	1.48	1.78	μ s
		Receiver	1		μ s
S_{DRT}	SIR Data Rate Tolerance. % of Nominal Data Rate.	Transmitter		$\pm 0.87\%$	
		Receiver		$\pm 2.0\%$	
t_{SJT}	SIR Leading Edge Jitter. % of Nominal Bit Duration.	Transmitter		$\pm 2.5\%$	
		Receiver		$\pm 6.5\%$	

Note 1. t_{BTN} is the nominal bit time in Serial Port, Sharp-IR, SIR and Consumer Remote Control modes. It is determined by the setting of the Baud Generator Divisor registers

Note 2. t_{CWN} is the nominal pulse width of the modulation signal for Sharp-IR and Consumer Remote Control modes. It is determined by the MCPW field (bits 7-5) of the IRTXMC register and the TXHSC bit (bit 2) of the RCCFG register

Note 3. t_{CPN} is the nominal period of the modulation signal for Sharp-IR and Consumer Remote Control modes. It is determined by the MCFR field (bits 4-0) of the IRTXMC register and the TXHSC bit (bit 2) of the RCCFG register.

Note 4. t_{MMIN} and t_{MMAX} define the time range within which the period of the incoming subcarrier signal has to fall in order for the signal to be accepted by the receiver. These time values are determined by the contents of the IRRXDC register and the setting of the RXHSC bit (bit 5) of the RCCFG register

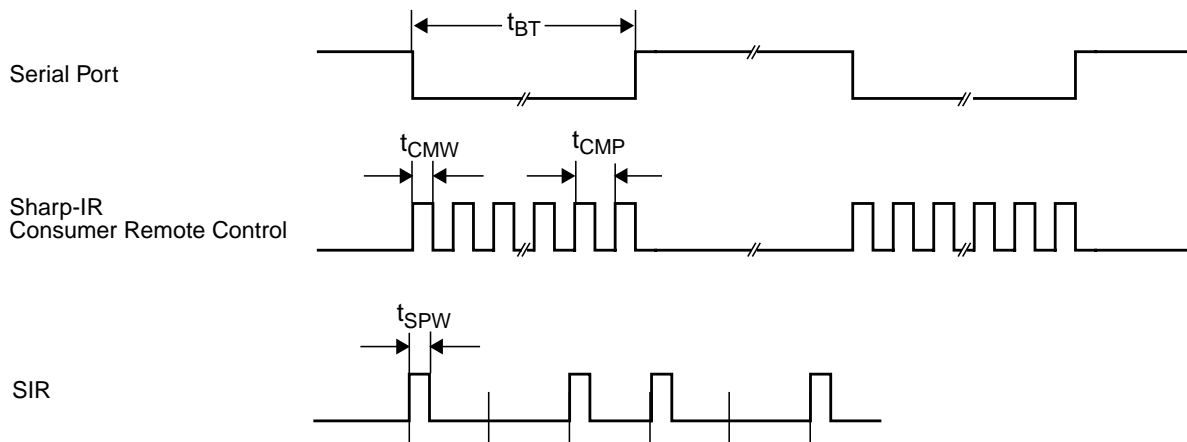

14.0 Device Characteristics (Continued)

14.5.6 Modem Control Timing

Symbol	Parameter	Min	Max	Unit
t_{HL}	$\overline{RI2,1}$ High to Low Transition	10		ns
t_{LH}	$\overline{RI2,1}$ Low to High Transition	10		ns
t_{SIM}	Delay to Set IRQ from Modem Input		40	ns

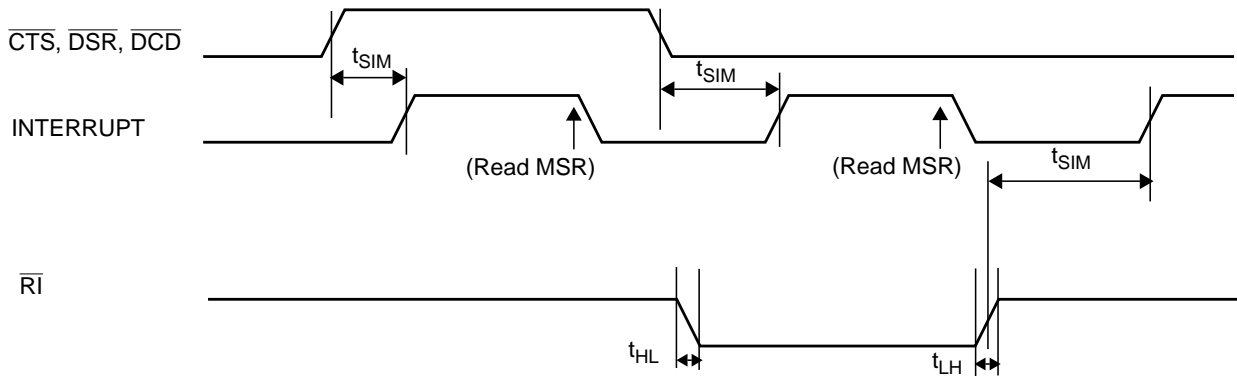

14.5.7 FDC Write Data Timing

Symbol	Parameter	Min	Max	Unit
t_{HDH}	\overline{HDSEL} Hold from \overline{WGATE} Inactive ^{Note 1.}	100		μs
t_{HDS}	\overline{HDSEL} Setup to \overline{WGATE} Active ^{Note 1.}	100		μs
t_{WDW}	Write Data Pulse Width	See t_{DRP} , t_{ICP} and t_{WDW} values in table below		

Note 1. Not tested. Guaranteed by design.

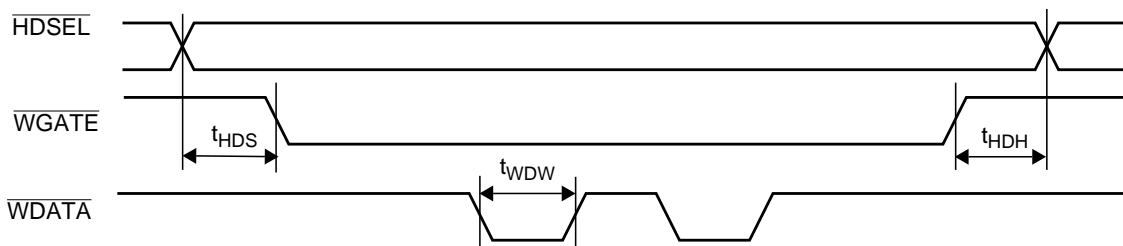

t_{DRP} t_{ICP} t_{WDW} Values

Data Rate	t_{DRP}	t_{ICP}	t_{ICP} Nominal	t_{WDW}	t_{WDW} Minimum	Unit
1 Mbps	1000	$6 \times t_{CP}$ ^{Note 1.}	125	$2 \times t_{ICP}$	250	ns
500 Kbps	2000	$6 \times t_{CP}$ ^{Note 1.}	125	$2 \times t_{ICP}$	250	ns
300 Kbps	3333	$10 \times t_{CP}$ ^{Note 1.}	208	$2 \times t_{ICP}$	375	ns
250 Kbps	4000	$12 \times t_{CP}$ ^{Note 1.}	250	$2 \times t_{ICP}$	500	ns

Note 1. t_{CP} is the clock period defined in the *LCLK* and *LRESET* section of this chapter.

14.0 Device Characteristics (Continued)

14.5.8 FDC Drive Control Timing

Symbol	Parameter	Min	Max	Unit
t_{DST}	\overline{DIR} Setup to \overline{STEP} Active ^{Note 1.}	6		μs
t_{IW}	Index Pulse Width	100		ns
t_{STD}	\overline{DIR} Hold from \overline{STEP} Inactive	t_{STR}		ms
t_{STP}	\overline{STEP} Active High Pulse Width ^{Note 1.}	8		μs
t_{STR}	\overline{STEP} Rate Time ^{Note 1.}	0.5		ms

Note 1. Not tested. Guaranteed by design.

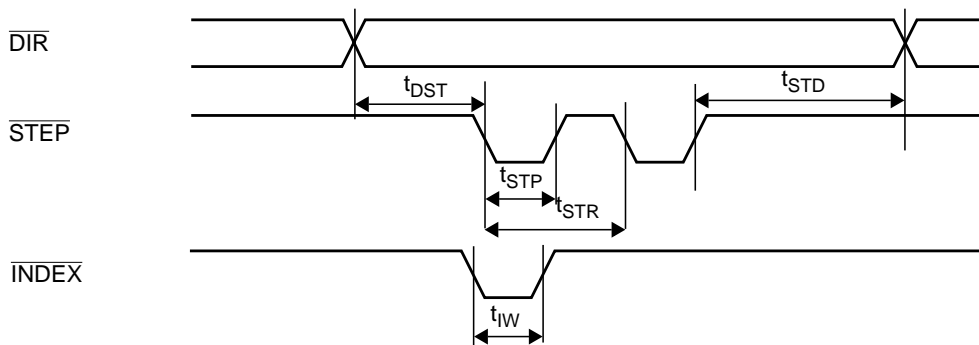

14.5.9 FDC Read Data Timing

Symbol	Parameter	Min	Max	Unit
t_{RDW}	Read Data Pulse Width	50		ns

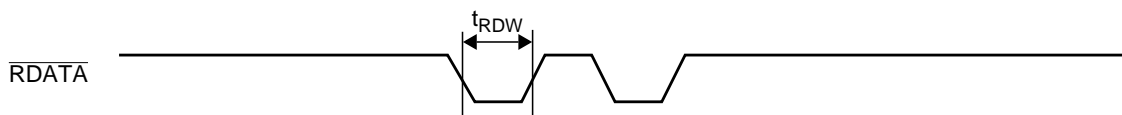

14.0 Device Characteristics (Continued)

14.5.10 Standard Parallel Port Timing

Symbol	Parameter	Conditions	Typ	Max	Unit
t_{PDH}	Port Data Hold	These times are system dependent and are therefore not tested.	500		ns
t_{PDS}	Port Data Setup	These times are system dependent and are therefore not tested.	500		ns
t_{SW}	Strobe Width	These times are system dependent and are therefore not tested.	500		ns

Typical Data Exchange

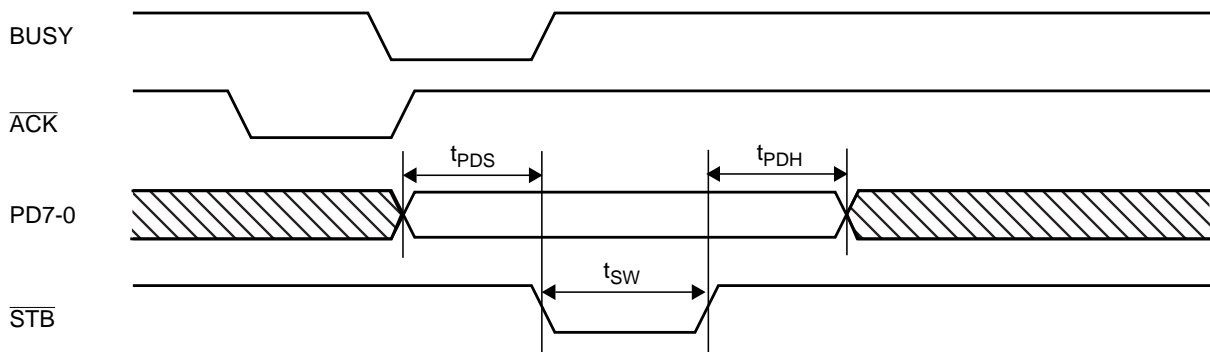

14.5.11 Enhanced Parallel Port Timing

Symbol	Parameter	Min	Max	EPP 1.7	EPP 1.9	Unit
t_{WW19a}	\overline{WRITE} Active from \overline{WAIT} Low		45		✓	ns
t_{WW19ia}	\overline{WRITE} Inactive from \overline{WAIT} Low		45		✓	ns
t_{WST19a}	\overline{DSTRB} or \overline{ASTRB} Active from \overline{WAIT} Low		65		✓	ns
t_{WEST}	\overline{DSTRB} or \overline{ASTRB} Active after \overline{WRITE} Active	10		✓	✓	ns
t_{WPDH}	PD7-0 Hold after \overline{WRITE} Inactive	0		✓	✓	ns
t_{WPDS}	PD7-0 Valid after \overline{WRITE} Active		15	✓	✓	ns
t_{EPDW}	PD7-0 Valid Width	80		✓	✓	ns
t_{EPDH}	PD7-0 Hold after \overline{DSTRB} or \overline{ASTRB} Inactive	0		✓	✓	ns

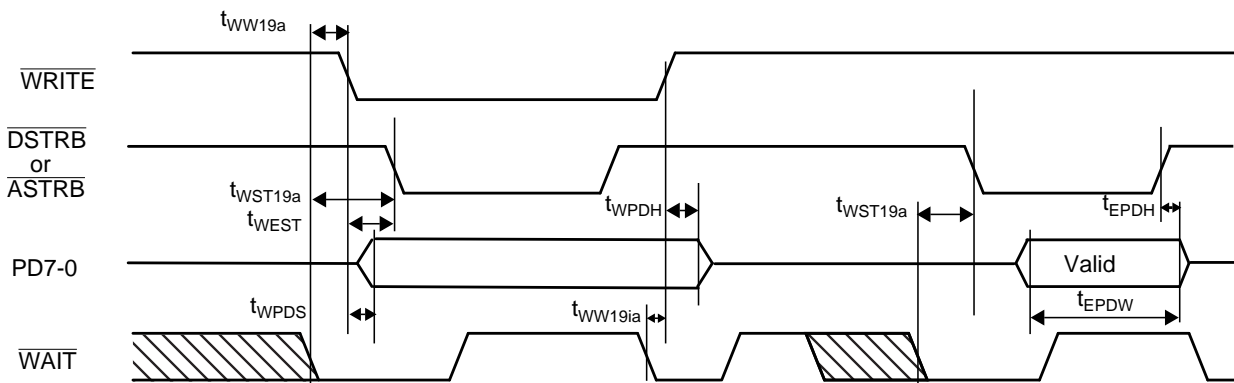

14.0 Device Characteristics (Continued)

14.5.12 Extended Capabilities Port (ECP) Timing

Forward Mode

Symbol	Parameter	Min	Max	Unit
t_{ECDSF}	Data Setup before \overline{STB} Active	0		ns
t_{ECDHF}	Data Hold after $BUSY$ Inactive	0		ns
t_{ECLHF}	$BUSY$ Active after \overline{STB} Active	75		ns
t_{ECHHF}	\overline{STB} Inactive after $BUSY$ Active	0	1	s
t_{ECHLF}	$BUSY$ Inactive after \overline{STB} Active	0	35	ms
t_{ECLLF}	\overline{STB} Active after $BUSY$ Inactive	0		ns

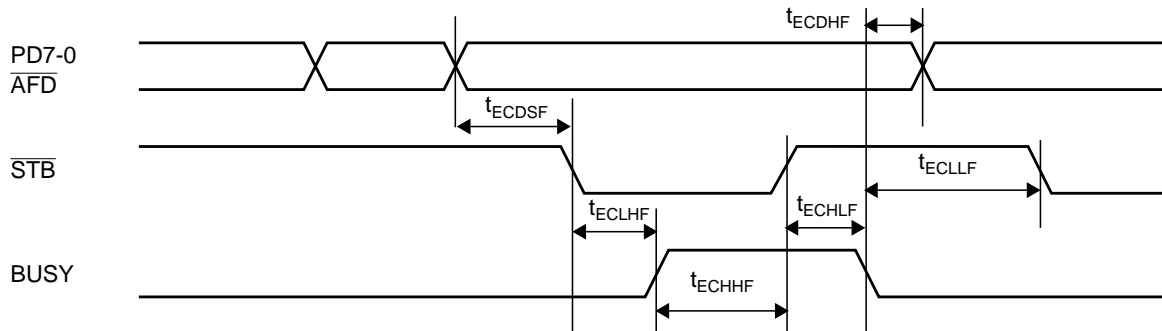

Reverse Mode

Symbol	Parameter	Min	Max	Unit
t_{ECDSR}	Data Setup before \overline{ACK} Active	0		ns
t_{ECDHR}	Data Hold after \overline{AFD} Active	0		ns
t_{ECLHR}	\overline{AFD} Inactive after \overline{ACK} Active	75		ns
t_{ECHHR}	\overline{ACK} Inactive after \overline{AFD} Inactive	0	35	ms
t_{ECHLR}	\overline{AFD} Active after \overline{ACK} Inactive	0	1	s
t_{ECLLR}	\overline{ACK} Active after \overline{AFD} Active	0		ns

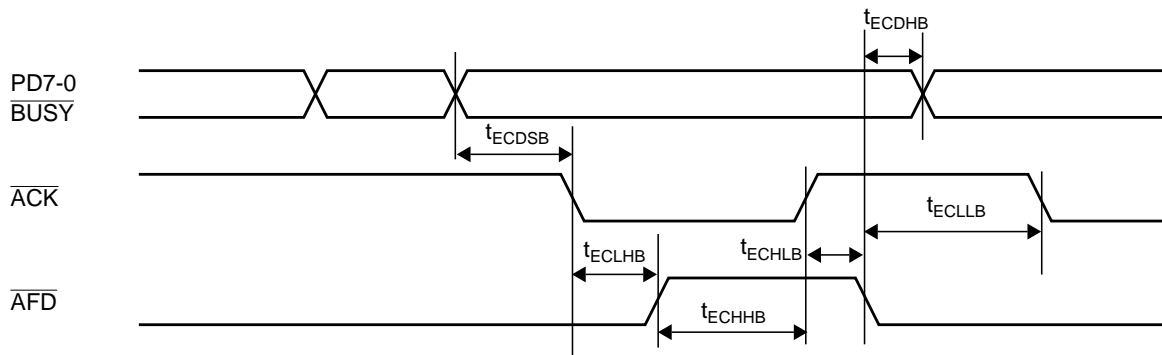

Physical Dimensions

All dimensions are in millimeters.

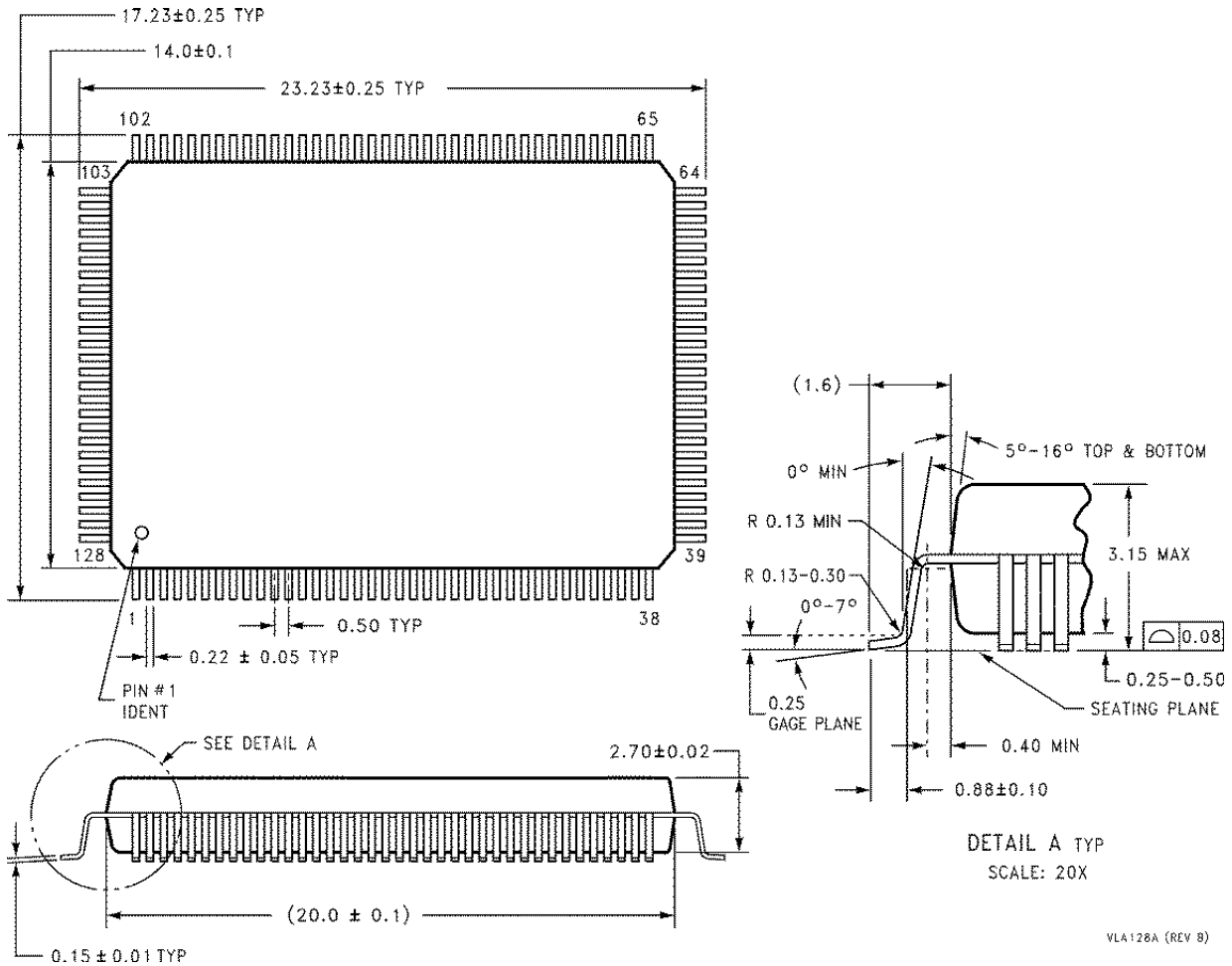

Plastic Quad Flatpack (PQFP), JEDEC
Order Number PC87366-xxx/VLA
NS Package Number VLA128A

VLA128A (REV 8)

LIFE SUPPORT POLICY

NATIONAL'S PRODUCTS ARE NOT AUTHORIZED FOR USE AS CRITICAL COMPONENTS IN LIFE SUPPORT DEVICES OR SYSTEMS WITHOUT THE EXPRESS WRITTEN APPROVAL OF THE PRESIDENT OF NATIONAL SEMICONDUCTOR CORPORATION. As used herein:

1. Life support devices or systems are devices or systems which, (a) are intended for surgical implant into the body, or (b) support or sustain life, and whose failure to perform, when properly used in accordance with instructions for use provided in the labeling, can be reasonably expected to result in a significant injury to the user.
2. A critical component is any component of a life support device or system whose failure to perform can be reasonably expected to cause the failure of the life support device or system, or to affect its safety or effectiveness.



National Semiconductor Corporation
 Fax: 1-800-737-7018
 Email: support@nsc.com
 Tel: 1-800-272-9959

National Semiconductor Europe
 Fax: (+49) 0-180-530 85 86
 Email: europe.support@nsc.com
 Deutsch Tel: (+49) 0-180-530 85 85
 English Tel: (+49) 0-180-532 78 32

National Semiconductor Asia Pacific Customer Response Group
 Fax: 65-250-4466
 Email: sea.support@nsc.com
 Tel: 65-254-4466

National Semiconductor Japan Ltd.
 Fax: 81-3-5620-6179
 Tel: 81-3-5620-6175

www.national.com