

# CLC021

## SMPTE 259M Digital Video Serializer with EDH Generation and Insertion

### General Description

The CLC021 SMPTE 259M Digital Video Serializer with EDH Generation and Insertion is a monolithic integrated circuit that encodes, serializes and transmits bit-parallel digital data conforming to SMPTE 125M and 267M component video and SMPTE 244M composite video standards. The CLC021 can also serialize other 8- or 10-bit parallel data. The CLC021 operates at data rates from below 100 Mbps to over 400 Mbps. The serial data clock frequency is internally generated and requires no external frequency setting, trimming or filtering components\*.

Functions performed by the CLC021 include: parallel-to-serial data conversion, ITU-R BT.601-4 input data clipping, data encoding using the SMPTE polynomial ( $X^9+X^4+1$ ), data format conversion from NRZ to NRZI, parallel data clock frequency multiplication and encoding with the serial data, and differential, serial output data driving. The CLC021 has circuitry for automatic EDH character and flag generation and insertion per SMPTE RP-165. The CLC021 has an exclusive built-in self-test (BIST) and video test pattern generator (TPG) with 16 component video test patterns: reference black, PLL and EQ pathologicals and modified colour bars in 4:3 and 16:9 raster formats for NTSC and PAL formats\*.

The CLC021 has inputs for enabling sync detection, non-SMPTE mode operation, enabling the EDH function, NRZ/NRZI mode control and an external reset control. Outputs are provided for H, V and F bits, new TRS sync character position indication, ancillary data header detection, NTSC/PAL raster indication and PLL lock detect. Separate power pins for the output driver, VCO and the serializer improve power supply rejection, output jitter and noise performance.

The CLC021AVGZ-5.0V is powered by a single +5V supply. The CLC021AVGZ-3.3V is powered by a single +3.3V supply. Power dissipation is typically 235 mW including two 75 $\Omega$  back-matched output loads. The device is packaged in a JEDEC metric 44-lead PQFP.

### Features

- SMPTE 259M serial digital video standard compliant
- Supports all NTSC and PAL standard component and composite serial video data rates
- No external serial data rate setting or VCO filtering components required\*
- Fast VCO lock time: <75  $\mu$ s at 270 Mbps
- Built-in self-test (BIST) and video test pattern generator (TPG) with 16 internal patterns\*
- Automatic EDH character and flag generation and insertion per SMPTE RP 165
- Non-SMPTE mode operation as parallel-to-serial converter
- NRZ-to-NRZI conversion control
- HCMOS/LSTTL-compatible data and control inputs and outputs for CLC021AVGZ-5.0, LVCMOS for CLC021AVGZ-3.3
- 75 $\Omega$  ECL-compatible, differential, serial cable-driver outputs
- Single power supply operation: 5V (CLC021AVGZ-5.0) or 3.3V (CLC021AVGZ-3.3) in TTL or ECL systems
- Low power: typically 235 mW
- JEDEC 44-lead metric PQFP package
- Commercial temperature range 0 $^{\circ}$ C to +70 $^{\circ}$ C

\* Patents applications made or pending.

### Applications

- SMPTE 259M parallel-to-serial digital video interfaces for:
  - Video cameras
  - VTRs
  - Telecines
  - Video test pattern generators and digital video test equipment
  - Video signal generators
- Non-SMPTE video applications
- Other high data rate parallel/serial video and data applications

### Typical Application

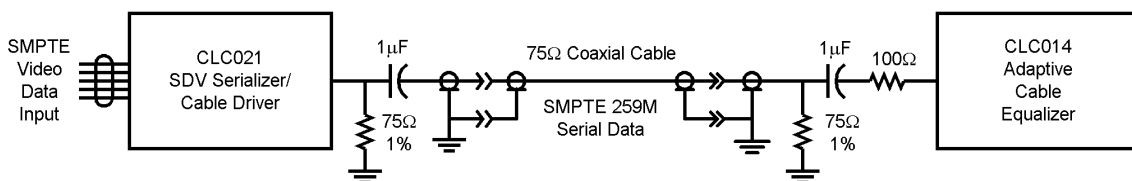

10136812

# Block Diagram

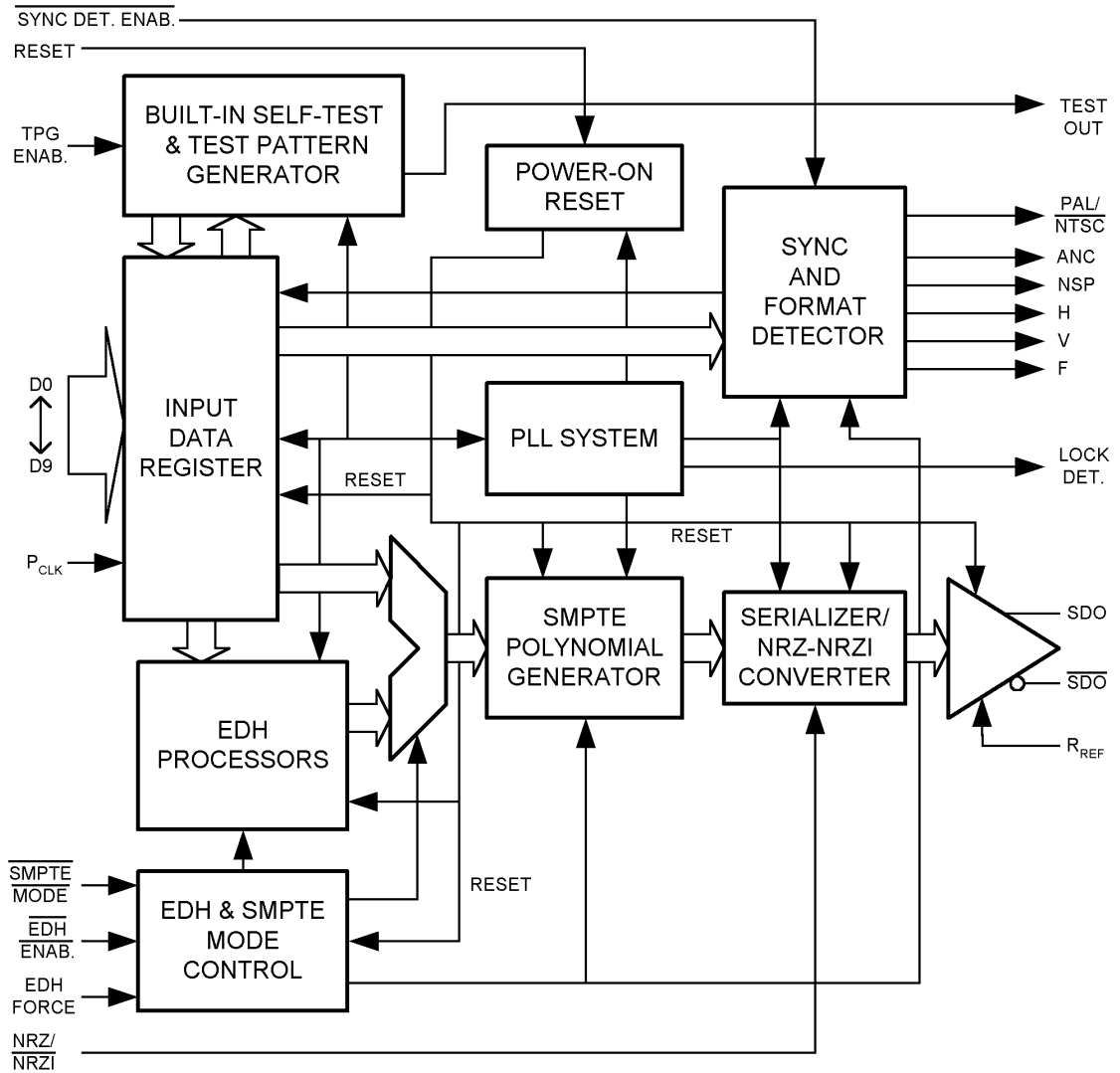

10136801

# Connection Diagram

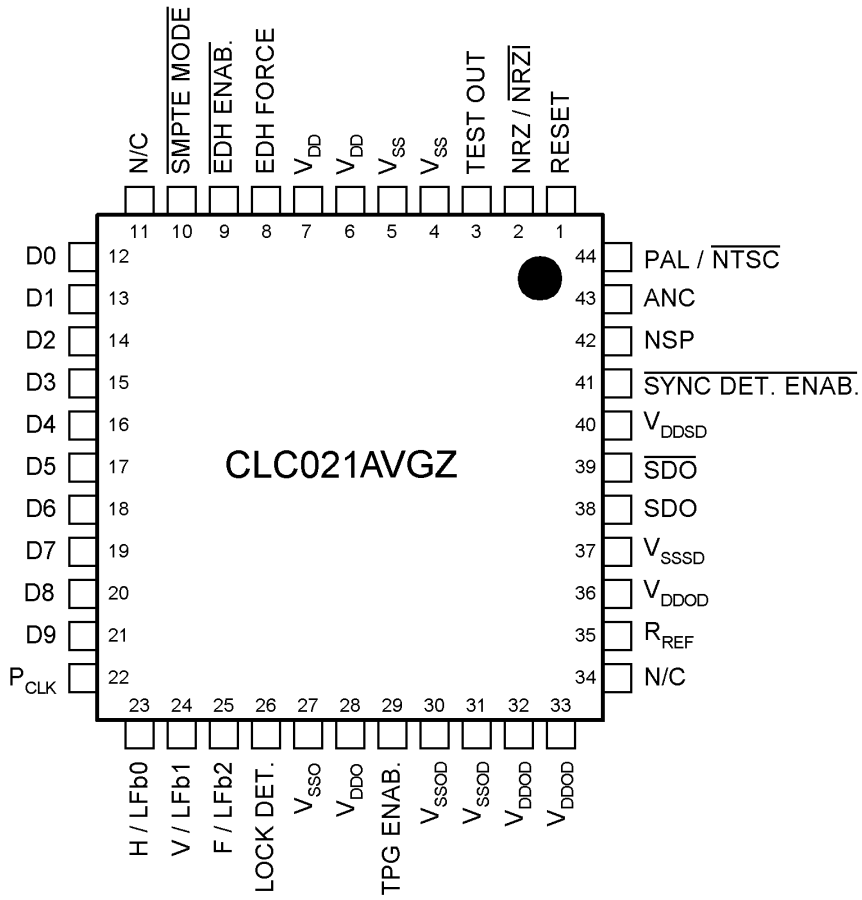

44-Pin Metric PQFP  
 Order Number CLC021AVGZ-5.0 or CLC021AVGZ-3.3  
 See NS Package Number VGZ44A

10136802

**Absolute Maximum Ratings** (Note 1) It is anticipated that this device will not be offered in a military qualified version. If Military/Aerospace specified devices are required, please contact the National Semiconductor Sales Office / Distributors for availability and specifications.

Supply Voltage ( $V_{DD}-V_{SS}$ ):	
CLC021AVGZ-5.0V	6.0V
CLC021AVGZ-3.3V	4.0V
CMOS/TTL Input Voltage ( $V_I$ ):	
CLC021AVGZ-5.0V	-0.5V to $V_{DD}+0.5V$
CLC021AVGZ-3.3V	-0.3V to $V_{DD}+0.3V$
CMOS/TTL Output Voltage ( $V_O$ ):	
CLC021AVGZ-5.0V	-0.5V to $V_{DD}+0.5V$
CLC021AVGZ-3.3V	-0.3V to $V_{DD}+0.3V$
CMOS/TTL Input Current (single input):	
$V_I = V_{SS} -0.5V$ :	-5 mA
$V_I = V_{DD} +0.5V$ :	+5 mA
Input Current, Other Inputs:	±1 mA
CMOS/TTL Output Source/Sink Current:	±16 mA
SDO Output Source Current:	22 mA
Package Thermal Resistance	
$\theta_{JA}$ 44-lead Metric PQFP:	
(@ 0 LFM airflow)	60°C/W
(@ 500 LFM airflow)	43°C/W

$\theta_{JC}$ 44-lead Metric PQFP:	17°C/W
Storage Temp. Range:	-65°C to +150°C
Junction Temperature:	+150°C
Lead Temperature (Soldering 4 Sec):	+260°C
ESD Rating (HBM):	2 kV
ESD Rating (MM):	150V
Transistor Count:	33,400

## Recommended Operating Conditions

Supply Voltage ( $V_{DD}-V_{SS}$ ):	
CLC021AVGZ-5.0	5.0V ±10%
CLC021AVGZ-3.3	3.3V ±10%
CMOS/TTL Input Voltage:	$V_{SS}$ to $V_{DD}$
Maximum DC Bias on SDO pins:	
CLC021AVGZ-5.0	3.0V ±10%
CLC021AVGZ-3.3	1.3V ±10%
$P_{CLK}$ Frequency Range	10 to 40MHz
$P_{CLK}$ Duty Cycle	45 to 55%
$D_N$ and $P_{CLK}$ Rise/Fall Time	1.0 to 3.0 ns
Operating Free Air Temperature ( $T_A$ ):	0°C to +70°C

## DC Electrical Characteristics—CLC021AVGZ-5.0

Over Supply Voltage and Operating Temperature ranges, unless otherwise specified (Notes 2, 3).

Symbol	Parameter	Conditions	Reference	Min	Typ	Max	Units
$V_{IH}$	Input Voltage High Level		All CMOS Inputs	2.0		$V_{DD}$	V
$V_{IL}$	Input Voltage Low Level			$V_{SS}$		0.8	V
$I_{IH}$	Input Current High Level	$V_{IH} = V_{DD}$			+40	+60	µA
$I_{IL}$	Input Current Low Level	$V_{IL} = V_{SS}$			-1	-20	µA
$V_{OH}$	CMOS Output Voltage High Level	$I_{OH} = -10$ mA	All CMOS Outputs	2.4	4.7	$V_{DD}$	V
$V_{OL}$	CMOS Output Voltage Low Level	$I_{OL} = +10$ mA		0.0	0.3	$V_{SS} + 0.5V$	V
$V_{SDO}$	Serial Driver Output Voltage	$R_L = 75\Omega$ 1%, $R_{REF} = 1.69$ kΩ 1%, Figure 2	SDO, $\overline{SDO}$	700	800	900	mV <sub>P-P</sub>
$I_{DD}$	Power Supply Current, Total	$R_L = 75\Omega$ 1%, $R_{REF} = 1.69$ kΩ 1%, $P_{CLK} = 27$ MHz, NTSC Colour Bar Pattern, Figure 2			47	60	mA

## DC Electrical Characteristics—CLC021AVGZ-3.3

Over Supply Voltage and Operating Temperature ranges, unless otherwise specified (Notes 2, 3).

Symbol	Parameter	Conditions	Reference	Min	Typ	Max	Units
$V_{IH}$	Input Voltage High Level		All CMOS Inputs	2.0		$V_{DD}$	V
$V_{IL}$	Input Voltage Low Level			$V_{SS}$		0.6	V
$I_{IH}$	Input Current High Level	$V_{IH} = V_{DD}$			+22	+60	µA
$I_{IL}$	Input Current Low Level	$V_{IL} = V_{SS}$			-1	-20	µA

**DC Electrical Characteristics—CLC021AVGZ-3.3** (Continued)

Over Supply Voltage and Operating Temperature ranges, unless otherwise specified (Notes 2, 3).

Symbol	Parameter	Conditions	Reference	Min	Typ	Max	Units
$V_{OH}$	CMOS Output Voltage High Level	$I_{OH} = -8$ mA	All CMOS Outputs	2.4	3.0	$V_{DD}$	V
$V_{OL}$	CMOS Output Voltage Low Level	$I_{OL} = +8$ mA		0.0	0.3	$V_{SS} + 0.5V$	V
$V_{SDO}$	Serial Driver Output Voltage	$R_L = 75\Omega$ 1%, $R_{REF} = 1.69$ k $\Omega$ 1%, <i>Figure 2</i>	SDO, $\overline{SDO}$	720	800	880	mV <sub>P-P</sub>
$I_{DD}$	Power Supply Current, Total	$R_L = 75\Omega$ 1%, $R_{REF} = 1.69$ k $\Omega$ 1%, $P_{CLK} = 27$ MHz, NTSC Colour Bar Pattern, <i>Figure 2</i>			33	55	mA

**AC Electrical Characteristics—CLC021AVGZ-5.0**

Over Supply Voltage and Operating Temperature ranges, unless otherwise specified (Note 3).

Symbol	Parameter	Conditions	Reference	Min	Typ	Max	Units	
$BR_{SDO}$	Serial Data Rate	(Note 5)	SDO, $\overline{SDO}$	100		400	Mbps	
$F_{PCLK}$	Reference Clock Input Frequency		$P_{CLK}$	10		40	MHz	
	Reference Clock Duty Cycle		$P_{CLK}$	45	50	55	%	
$t_r, t_f$	Rise Time, Fall Time		$D_N, P_{CLK}$	1.0	1.5	3.0	ns	
$t_j$	Serial Output Jitter	270 Mbps, <i>Figure 2</i> , (Note 6)	SDO, $\overline{SDO}$		220		ps <sub>P-P</sub>	
$t_{jit}$	Serial Output Jitter	(Notes 4, 5)			100	200	ps <sub>P-P</sub>	
$t_r, t_f$	Rise Time, Fall Time	20%–80%, (Notes 4, 5)			500	800	1500	ps
	Output Overshoot	(Note 4)				1		%
$t_{LOCK}$	Lock Time	(Notes 5, 7)				75		$\mu$ s
$t_{SU}$	Setup Time	<i>Figure 3</i> (Note 4)	$D_N$ to $P_{CLK}$	3	2		ns	
$t_{HLD}$	Hold Time	<i>Figure 3</i> (Note 4)	$D_N$ from $P_{CLK}$	3	2		ns	
$L_{GEN}$	Output Inductance	(Note 4)	SDO, $\overline{SDO}$		6		nH	
$R_{GEN}$	Output Resistance	(Note 4)				25k		$\Omega$

**AC Electrical Characteristics—CLC021AVGZ-3.3**

Over Supply Voltage and Operating Temperature ranges, unless otherwise specified (Note 3).

Symbol	Parameter	Conditions	Reference	Min	Typ	Max	Units	
$BR_{SDO}$	Serial Data Rate	(Note 5)	SDO, $\overline{SDO}$	100		400	Mbps	
$F_{PCLK}$	Reference Clock Input Frequency		$P_{CLK}$	10		40	MHz	
	Reference Clock Duty Cycle		$P_{CLK}$	45	50	55	%	
$t_r, t_f$	Rise Time, Fall Time		$D_N, P_{CLK}$	1.0	1.5	3.0	ns	
$t_j$	Serial Output Jitter	270 Mbps, <i>Figure 2</i> , (Note 6)	SDO, $\overline{SDO}$		220		ps <sub>P-P</sub>	
$t_{jit}$	Serial Output Jitter	(Notes 4, 5)			100	200	ps <sub>P-P</sub>	
$t_r, t_f$	Rise Time, Fall Time	20%–80%, (Notes 4, 5)			500	800	1500	ps
	Output Overshoot	(Note 4)				1		%
$t_{LOCK}$	Lock Time	(Notes 5, 7)				75		$\mu$ s
$t_{SU}$	Setup Time	<i>Figure 3</i> (Note 4)	$D_N$ to $P_{CLK}$	4	2		ns	
$t_{HLD}$	Hold Time	<i>Figure 3</i> (Note 4)	$D_N$ from $P_{CLK}$	4	2		ns	

## AC Electrical Characteristics—CLC021AVGZ-3.3 (Continued)

Over Supply Voltage and Operating Temperature ranges, unless otherwise specified (Note 3).

Symbol	Parameter	Conditions	Reference	Min	Typ	Max	Units
$L_{GEN}$	Output Inductance	(Note 4)	SDO, $\overline{SDO}$		6		nH
$R_{GEN}$	Output Resistance	(Note 4)			25k		$\Omega$

**Note 1:** "Absolute Maximum Ratings" are those parameter values beyond which the life and operation of the device cannot be guaranteed. The stating herein of these maximums shall not be construed to imply that the device can or should be operated at or beyond these values. The table of "Electrical Characteristics" specifies acceptable device operating conditions.

**Note 2:** Current flow into device pins is defined as positive. Current flow out of device pins is defined as negative. All voltages are stated referenced to  $V_{SS} = 0V$ .

**Note 3:** Typical values are stated for  $V_{DD} = +5.0V$  (CLC021AVGZ-5.0) or  $+3.3V$  (CLC021AVGZ-3.3) and  $T_A = +25^\circ C$ .

**Note 4:** Specification is guaranteed by design.

**Note 5:**  $R_L = 75\Omega$ , AC-coupled @ 270 Mbps,  $R_{REF} = 1.69 k\Omega$  1%, See *Test Loads* and *Figure 2*.

**Note 6:** CLC021 mounted in the SD021EVK board, configured in BIST mode (NTSC colour bars) with  $P_{CLK} = 27$  MHz derived from Tektronix TG2000 black-burst reference. Timing jitter measured with Tektronix VM700T using jitter measurement FFT mode, frame rate, 1 kHz filter bandwidth, Hanning window.

**Note 7:** Measured from rising-edge of first  $P_{CLK}$  cycle until Lock Detect output goes high (true).

### Test Loads

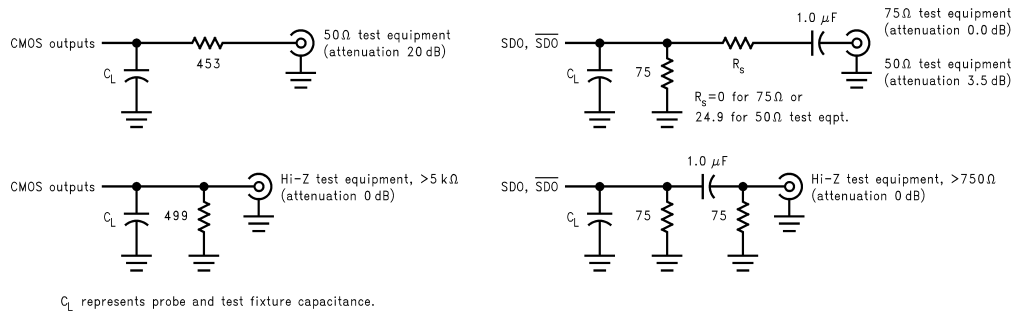

10136803

FIGURE 1. Test Loads

**Test Loads** (Continued)

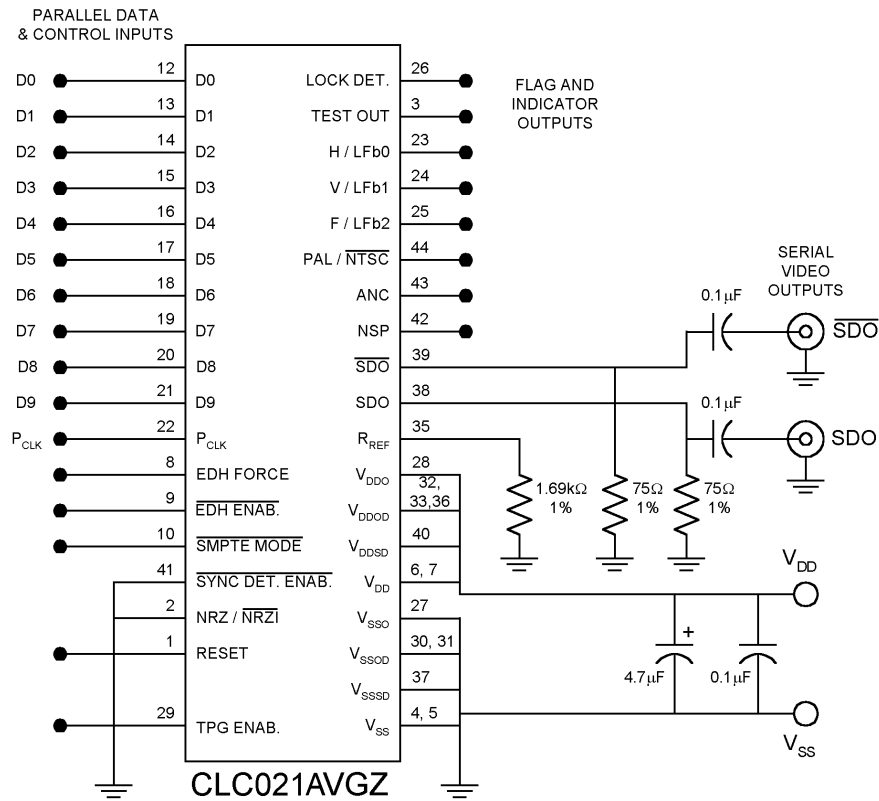

10136804

**FIGURE 2. Test Circuit**

## Timing Diagram

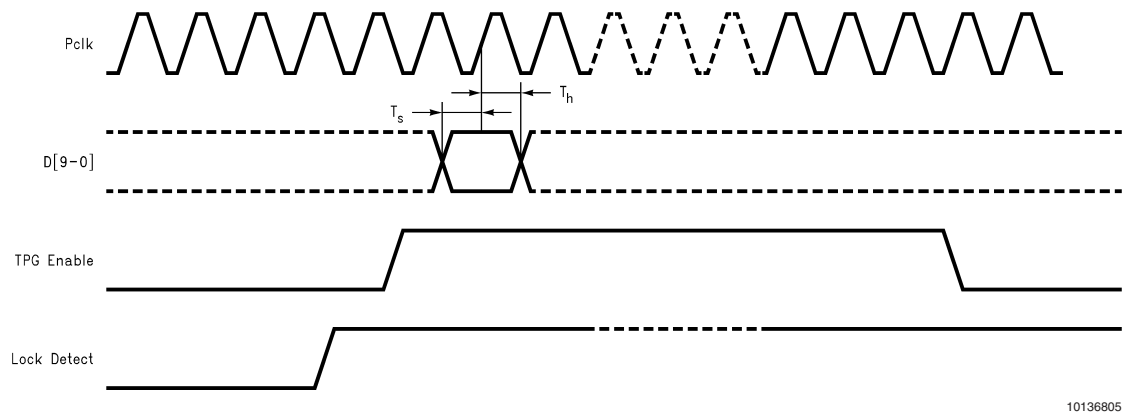

10136805

FIGURE 3. Setup and Hold Timing

## Device Operation

The CLC021 SMPTE 259M Serial Digital Video Serializer is used in digital video signal origination equipment: cameras, video tape recorders, telecines and video test and other equipment. It converts parallel component or composite digital video signals into serial format. Logic levels within this equipment are normally TTL-compatible as produced by CMOS or bipolar logic devices. The encoder produces ECL-compatible serial digital video (SDV) signals conforming to SMPTE 259M-1997. The CLC021 operates at all standard SMPTE and ITU-R parallel data rates. In addition, the CLC021 can serialize other 8- and 10-bit data.

### VIDEO DATA PROCESSING CIRCUITS

The **input data register** accepts 8- or 10-bit parallel data and clock signals having HCMOS/LSTTL-compatible signal levels. Parallel data may conform to any of several standards: SMPTE 125M, SMPTE 267M, SMPTE 244M or ITU-R BT.601. If the data is 8-bit, it is converted to a 10-bit representation according to the type of data being input: component 4:2:2 per SMPTE 259M paragraph 7.1.1, composite NTSC per paragraph 8.1.1 or composite PAL per paragraph 9.1.1. Eight-bit video data corresponds to the upper 8 bits of the 10-bit video data word and is MSB-aligned. Output from this register feeds the TRS (sync) character detector, SMPTE polynomial generator/serializer and the EDH polynomial generators/serializers and control system. All parallel data and clock inputs have internal pull-down devices.

The **sync detector** or TRS character detector receives data from the input register. The detection function is controlled by Sync Detect Enable, a low-true, TTL-compatible, external signal. Synchronization words, the timing reference signals (TRS), start-of-active-video (SAV) and end-of-active-video (EAV) are defined in SMPTE 125M and 244M. The sync detector supplies control signals to the SMPTE polynomial generator to identify the presence of valid video data, and to the EDH control block. In SMPTE mode, TRS character LSB-clipping as prescribed in ITU-R BT.601 is enabled. LSB-clipping causes all TRS characters with a value between 000h and 003h to be forced to 000h and all TRS characters with a value between 3FCh and 3FFh to be forced to 3FFh.

Clipping is done prior to encoding or EDH character generation. This function is disabled in non-SMPTE mode operation.

Outputs from the sync detector are:

1. **H, V, and F or Line/Field ID**—For component video, these are registered outputs corresponding to input TRS data bits 6, 7 and 8, respectively. These outputs are disabled in non-SMPTE mode. The outputs are active HIGH-true. For composite video, these outputs correspond to the line and field ID encoded as input parallel data bits 2 (MSB) through 0. These outputs are registered for the duration of the applicable field.
2. **NSP**—New Sync Position: A function and output indicating that a new or out-of-place TRS character has been detected. This output remains active for at least one horizontal line period (reset by EAV) or unless re-activated by a subsequent new or out-of-place TRS. Activation of this function flushes the existing state of the machine resetting the EDH generator, SMPTE polynomial generator, serializer and NRZ-NRZI converter. This function is disabled in non-SMPTE mode operation. The output is active HIGH-true.
3. **ANC**—Ancillary data location output: Indicates that the ancillary data header (component) or flag (composite) has been detected. The output is a pulse having a duration of one  $P_{CLK}$  period. The output is active HIGH-true.

### SMPTE POLYNOMIAL GENERATOR AND CONTROLS

The **SMPTE Mode** input allows the CLC021 to function both as a full SMPTE 259M encoder or general-purpose 8- or 10-bit serializer. SMPTE mode is enabled when this input is LOW. Non-SMPTE mode is enabled when this pin is HIGH. This pin is pulled internally to  $V_{SS}$  when unconnected. When in SMPTE mode, the SMPTE polynomial generator; TRS sync detection circuitry; EDH control circuitry; H, V, F and NSP outputs and TRS clipping are enabled.

The **SMPTE polynomial generator** accepts the parallel video data and encodes it using the polynomial  $X^9 + X^4 + 1$  as specified in SMPTE 259M (1997 rev.), paragraph 5 and Annex C. The transmission bit order is LSB-first, per paragraph 6.



## Device Operation (Continued)

### NRZ-TO-NRZI CONVERTER

The **NRZ-to-NRZI converter** accepts NRZ serial data from the SMPTE and EDH polynomial generators and converts it to NRZI using the polynomial  $(X + 1)$  per SMPTE 259M, paragraph 5.2 and Annex C. The converter's output goes to the output buffer amplifier. The **NRZ/NRZI input** enables this conversion function. Conversion from NRZ to NRZI is enabled when the input is a logic LOW. Conversion to NRZI is disabled when this input is a logic-HIGH. This function is not affected by the SMPTE mode control input. The input pin is pulled internally to  $V_{SS}$  (NRZI enabled) when unconnected.

### EDH SYSTEM OPERATION

The CLC021 has EDH character and flag generation and insertion circuitry which operates as proposed in SMPTE RP-165. Inputs and circuitry are provided to control generation and automatic insertion of the EDH check words at proper locations in the serial data output.

The **EDH polynomial generators** accept parallel data from the input register and generate 16-bit serial check words using the polynomial  $X^{16} + X^{12} + X^6 + 1$ . Separate calculations are made for each video field prior to serialization. Separate CRCs for the full-field and active picture along with status flags are inserted and serially transmitted with the other data. Upon being reset, the initial state of all EDH check characters is 00h.

The **EDH control** system accepts input from the sync detector and controls the EDH polynomial generator and SMPTE/EDH polynomial insertion multiplexer. **EDH Enable**, an external TTL-compatible, low-true input, enables this circuitry. The controller inserts the EDH check words in the serial data stream at the correct positions in the ancillary data space per SMPTE 259M paragraph 7.3, 8.4.4 or 9.4.4 and per SMPTE RP-165. Ancillary data space is formatted per SMPTE 291M.

The **EDH Force** control input causes the insertion of new EDH checkwords and flags into the serial output regardless of the previous condition of EDH checkwords and flags in the input parallel data. This function may be used in situations where video content has been edited thus making the previous EDH information invalid.

The **NTSC/PAL** output indicates the type of component or composite data standard being input to the CLC021. This output is useful for troubleshooting or may be used to drive a panel indicator. The output is high when 625-line PAL data is being input and low when 525-line NTSC data is being input.

### PHASE-LOCKED LOOP AND VCO

The **phase-locked loop** (PLL) system generates the output serial data clock at 10x the parallel data clock frequency. This system consists of a VCO, divider chain, phase-frequency detector and internal loop filter. The VCO free-

running frequency is internally set. The PLL automatically generates the appropriate frequency for the serial clock rate using the parallel data clock ( $P_{CLK}$ ) frequency as its reference. Loop filtering is internal to the CLC021. The VCO halts when no  $P_{CLK}$  signal is present or is inactive.  $P_{CLK}$  should be applied after power to the device.

The VCO has separate  $V_{SSO}$  and  $V_{DDO}$  power supply feeds, pins 27 and 28, which may be supplied power via an external low-pass filter, if desired. The PLL acquisition (lock) time is less than 75  $\mu$ s @ 270 Mbps.

### LOCK DETECT

The lock detect output (pin 26) of the phase-frequency detector is a logic HIGH when the loop is locked. The output is CMOS/TTL-compatible and is suitable for driving other CMOS devices or an LED indicator. The Lock Detect pin reports the status of the PLL. When  $P_{CLK}$  is lost, it will switch low at the event.

### SERIAL DATA OUTPUT BUFFER

The current-mode **serial data outputs** provide low-skew complimentary or differential signals. The output buffer design can drive 75 $\Omega$  coaxial cables (AC-coupled) or 10K/100K ECL/PECL-compatible devices (DC-coupled). Output levels are 800 mV<sub>P-P</sub>  $\pm$ 10% into 75 $\Omega$  AC-coupled, back-matched loads. The output level is 400 mV<sub>P-P</sub>  $\pm$ 10% when DC-coupled into 75 $\Omega$ . (See Application Information for details.) The 75 $\Omega$  resistors connected to the SDO outputs are back-matching resistors. No series back-matching resistors should be used. Output level is controlled by the value of  $R_{REF}$  connected to pin 35. The value of  $R_{REF}$  is normally 1.69 k $\Omega$ ,  $\pm$ 1%. The output buffer is static when the device is in an out-of-lock condition. Separate  $V_{SSD}$  and  $V_{DDSD}$  power feeds, pins, 37 and 40 are provided for the serial output driver.

### POWER-ON RESET AND RESET INPUT

The CLC021 has an internally controlled, automatic, **power-on-reset** circuit. Reset clears TRS detection circuitry, all latches, registers, counters and polynomial generators, sets the EDH characters to 00h and disables the serial output. The SDO outputs are tri-stated during power-on reset. The part will remain in the reset condition until the parallel input clock is applied.

An active-HIGH-true, manual **reset input** is available at pin 1. It resets both the digital and PLL blocks. The reset input has an internal pull-down device and is inactive when unconnected.

It is recommended that  $P_{CLK}$  not be asserted until at least 30  $\mu$ s after power has reached  $V_{DDmin}$ . See *Figure 4*. If manual reset is used during power-on, then  $P_{CLK}$  may be asserted at any time as long as manual reset is not de-asserted until  $V_{DDmin}$  is reached. See *Figure 5*.

## Device Operation (Continued)

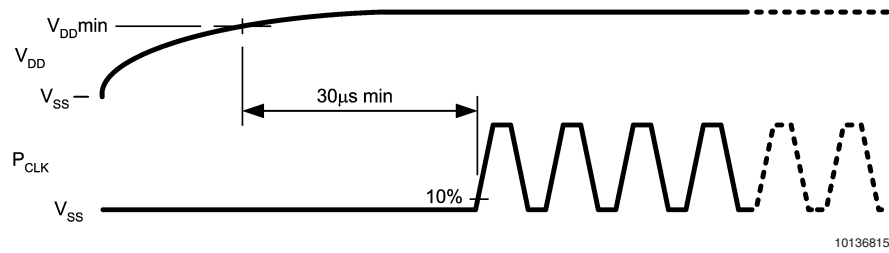

10136815

FIGURE 4. Power-On Reset Sequence

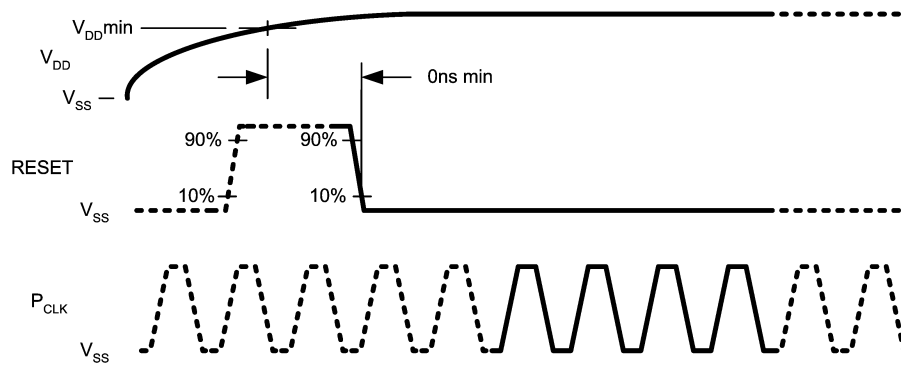

10136814

FIGURE 5. Power-On Reset Sequence with Manual Reset

### BUILT-IN SELF-TEST (BIST)

The CLC021 has a **built-in self-test (BIST)** function. The BIST performs a comprehensive go/no-go test of the device. The test uses either a full-field colour bar for NTSC or a PLL pathological for PAL as the test data pattern. Data is input internally in the input data register, processed through the device and tested for errors. A go/no-go indication is given at the Test\_Output. *Table 1* gives device pin functions and *Table 2* gives the test pattern codes used for this function. The signal level at Test\_Output, pin 3, indicates a pass or fail condition.

The BIST is initiated by applying the code for the desired BIST to D0 through D3 (D9 through D4 are 00h) and a 27 MHz clock at the  $P_{CLK}$  input. Since all parallel data inputs are

equipped with an internal pull-down device, only those inputs D0 through D3 which require a logic-1 need be pulled high. After the Lock\_Detect output goes high indicating the VCO is locked on frequency, TPG\_Enable, pin 29, is taken to a logic high. The Lock\_Detect output may be temporarily connected to TPG\_Enable to automate BIST operation. Test\_Output, pin 3, is monitored for a pass/fail indication. If no errors have been detected, this output will go to a logic high level approximately 2 field intervals after TPG\_Enable is taken high. If errors have been detected in the internal circuitry of the CLC021, Test\_Output will remain low until the test is terminated. The BIST is terminated by taking TPG\_Enable to a logic low. Continuous serial data output is available during the test.

Device Operation (Continued)

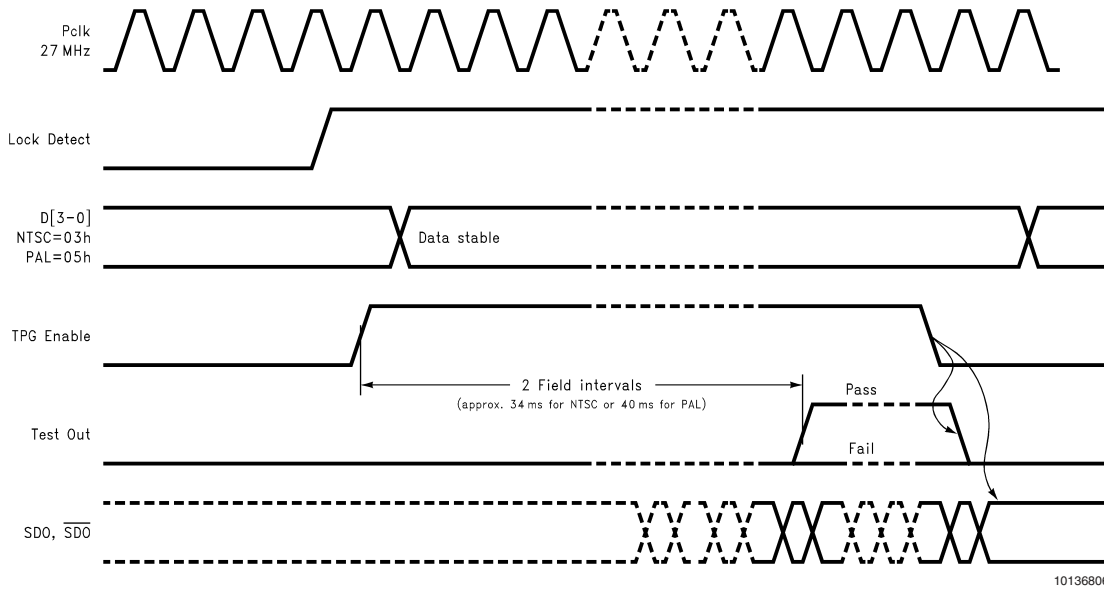

FIGURE 6. Built-In Self-Test Control Sequence

TEST PATTERN GENERATOR

The CLC021 includes an on-board **test pattern generator (TPG)**. Four full-field component video test patterns for both NTSC and PAL standards, and 4x3 and 16x9 raster sizes are produced. The test patterns are: flat-field black, PLL pathological, equalizer (EQ) pathological and a modified 75%, 8-colour vertical bar pattern. The pathologicals follow recommendations contained in SMPTE RP 178–1996 regarding the test data used. The colour bar pattern does not incorporate bandwidth limiting coding in the chroma and luma data when transitioning between the bars. For this reason, it may not be suitable for use as a visual test pattern or for input to video D-to-A conversion devices unless measures are taken to restrict the production of out-of-band frequency components.

The TPG is operated by applying the code for the desired test pattern to D0 through D3 (D4 through D9 are 00h). Since all parallel data inputs are equipped with internal pull-down devices, only those inputs D0 through D3 which require a logic-1 need be pulled high. Next, apply a 27 MHz or 36 MHz signal, appropriate to the raster size desired, at the P<sub>CLK</sub> input and wait until the Lock\_Detect output goes true indicating the VCO is locked on frequency. Then, take TPG\_Enable, pin 29, to a logic high. The serial test pattern data appears on the SDO outputs. The Lock\_Detect output may be temporarily connected to TPG\_Enable to automate TPG operation. The TPG mode is exited by taking TPG\_Enable to a logic low. *Table 1* gives device pin functions for this mode. *Table 2* gives the available test patterns and selection codes.

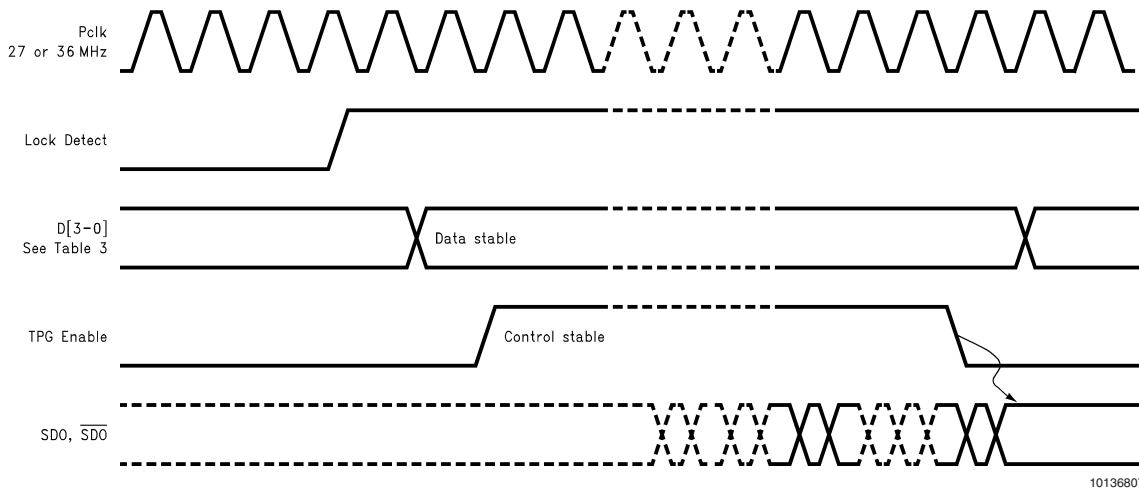

FIGURE 7. Test Pattern Generator Control Sequence

## Device Operation (Continued)

**TABLE 1. BIST and Test Pattern Generator Control Functions**

Pin	Name	Function
12	D0	TPG Code Input LSB
13	D1	TPG Code Input
14	D2	TPG Code Input
15	D3	TPG Code Input MSB
29	TPG_EN	TPG Enable, Active High True
3	Test_Out	BIST Pass/Fail Output. Pass=High (See text for Timing Requirements)

**TABLE 2. Component Video Test Pattern Selection**

Standard	Frame	Test Pattern	D3	D2	D1	D0
NTSC	4x3	Flat-Field Black	0	0	0	0
NTSC	4x3	PLL Pathological	0	0	0	1
NTSC	4x3	EQ Pathological	0	0	1	0
NTSC	4x3	Colour Bars, 75%, 8-Bars (modified, see text), BIST	0	0	1	1
PAL	4x3	Flat-Field Black	0	1	0	0
PAL	4x3	PLL Pathological, BIST	0	1	0	1
PAL	4x3	EQ Pathological	0	1	1	0
PAL	4x3	Colour Bars, 75%, 8-Bars (modified, see text)	0	1	1	1
NTSC	16x9	Flat-Field Black	1	0	0	0
NTSC	16x9	PLL Pathological	1	0	0	1
NTSC	16x9	EQ Pathological	1	0	1	0
NTSC	16x9	Colour Bars, 75%, 8-bars (modified, see text)	1	0	1	1
PAL	16x9	Flat-Field Black	1	1	0	0
PAL	16x9	PLL Pathological	1	1	0	1
PAL	16x9	EQ Pathological	1	1	1	0
PAL	16x9	Colour Bars, 75%, 8-Bars (modified, see text)	1	1	1	1

**Note:** D9 through D4 = 0 (binary)

## Pin Descriptions

Pin	Name	Description
1	Reset	Manual Reset Input (High True)
2	NRZ-NRZI	NRZ-to-NRZI Conversion Control (NRZ=High, NRZI=Low)
3	Test Out	Test Out (BIST Pass/Fail Indicator)
4	V <sub>SS</sub>	Negative Power Supply Input (Digital Logic)
5	V <sub>SS</sub>	Negative Power Supply Input (Digital Logic)
6	V <sub>DD</sub>	Positive Power Supply Input (Digital Logic)
7	V <sub>DD</sub>	Positive Power Supply Input (Digital Logic)
8	EDH Force	Force Insertion of New EDH and Flags in Serial Output Data (High True)
9	EDH Enable	EDH Enable Input (Low True)
10	SMPTE Mode	SMPTE/non-SMPTE Mode Select Input (SMPTE Mode=Low)
11	N/C	No Connect
12	D0	Parallel Data Input (Internal Pull-Down to V <sub>SS</sub> )
13	D1	Parallel Data Input (Internal Pull-Down to V <sub>SS</sub> )
14	D2	Parallel Data Input (Internal Pull-Down to V <sub>SS</sub> )
15	D3	Parallel Data Input (Internal Pull-Down to V <sub>SS</sub> )
16	D4	Parallel Data Input (Internal Pull-Down to V <sub>SS</sub> )
17	D5	Parallel Data Input (Internal Pull-Down to V <sub>SS</sub> )
18	D6	Parallel Data Input (Internal Pull-Down to V <sub>SS</sub> )
19	D7	Parallel Data Input (Internal Pull-Down to V <sub>SS</sub> )
20	D8	Parallel Data Input (Internal Pull-Down to V <sub>SS</sub> )
21	D9	Parallel Data Input (Internal Pull-Down to V <sub>SS</sub> )
22	P <sub>CLK</sub>	Parallel Clock Input (Internal Pull-Down to V <sub>SS</sub> )
23	H/Line-Field b0 (LSB)	H-Bit Output (Component); Line-Field ID (Composite)
24	V/Line-Field b1	V-Bit Output (Component); Line-Field ID (Composite)
25	F/Line-Field b2 (MSB)	F-Bit Output (Component); Line-Field ID (Composite)
26	Lock Detect	Lock Detector Output (High True)
27	V <sub>SSO</sub>	Negative Power Supply Input (PLL Supply)
28	V <sub>DDO</sub>	Positive Power Supply Input (PLL Supply)
29	TPG Enable	TPG Enable (High True)
30	V <sub>SSOD</sub>	Negative Power Supply Input (PLL Digital Supply)
31	V <sub>SSOD</sub>	Negative Power Supply Input (PLL Digital Supply)
32	V <sub>DDOD</sub>	Positive Power Supply Input (PLL Digital Supply)
33	V <sub>DDOD</sub>	Positive Power Supply Input (PLL Digital Supply)
34	N/C	No Connect
35	R <sub>REF</sub>	Output Level Reference Resistor (1.69 kΩ, 1% Nominal Value)
36	V <sub>DDOD</sub>	Positive Power Supply Input (PLL Digital Supply)
37	V <sub>SSSD</sub>	Negative Power Supply Input (Output Driver)
38	SDO	Serial Data True Output
39	$\overline{\text{SDO}}$	Serial Data Complement Output
40	V <sub>DDSD</sub>	Positive Power Supply Input (Output Driver)
41	Sync Detect Enable	Parallel Data Sync Detection Enable Input (Low True)
42	NSP	New Sync Position Output
43	ANC	Ancillary Data Header Flag Output
44	$\overline{\text{NTSC/PAL}}$	NTSC/PAL Mode Indicator Output (PAL=High, NTSC=Low)

**Note:** All CMOS/TTL inputs have internal pull-down devices.

## Application Information

A typical application circuit for the CLC021 is shown in *Figure 8*. This circuit demonstrates the capabilities of the CLC021 and allows its evaluation in a variety of configurations. Assembled demonstration boards with more comprehensive evaluation options are available, part number SD021-5EVK (5V device) or SD021-3EVK (3.3V device).

The boards may be ordered through any of National's sales offices. Complete circuit board layouts and schematics including Gerber photoplot files, for the demonstration boards are available on National's WEB site in the application information for this device. For latest information, please see: [www.national.com/appinfo/interface](http://www.national.com/appinfo/interface).

### APPLICATION CIRCUIT

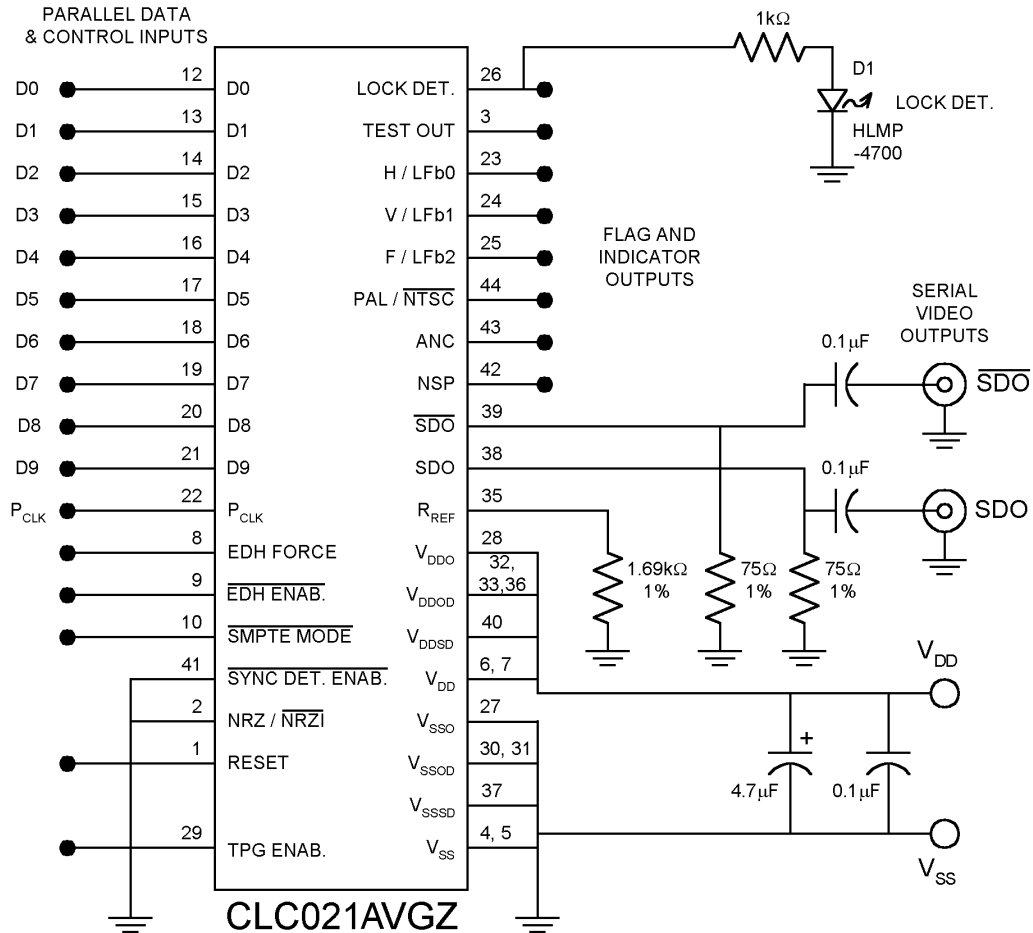

10136808

FIGURE 8. Typical Application Circuit

The SD021EVK application circuit boards, *Figure 9*, can accommodate different input and output drive and loading options. Pin headers are provided for input and control I/O signal access. Install the appropriate value resistor packs, 220Ω at RP1 and RP3 and 330Ω at RP2 and RP4, for TTL cabled interfaces before applying input signals. Install 51Ω resistor packs at RP2 and RP4 for signal sources requiring such loading. Remove any resistor packs at RP1 and RP3 when using 50Ω source loading.

The board's outputs may be DC interfaced to PECL inputs by first installing 124Ω resistors at R1B and R2B, changing R1A and R2A to 187Ω and replacing C1 and C2 with short circuits. The PECL inputs should be directly connected to J1 and J2 without cabling. If 75Ω cabling is used to connect the CLC021 to the PECL inputs, the voltage dividers used on the

CLC021 outputs must be removed and re-installed on the circuit board where the PECL device is mounted. This will provide correct termination for the cable and biasing for both the CLC021's outputs and the PECL inputs. It is most important to note that a 75Ω or equivalent DC loading (measured with respect to the negative supply rail) must always be installed at both of the CLC021's SDO outputs to obtain proper signal levels from device. When using 75Ω Thevenin-equivalent load circuits, the DC bias applied to the SDO outputs should not exceed +3V (+1.3V for CLC021AVGZ-3.3) with respect to the negative supply rail. Serial output levels should be reduced to 400 mV<sub>p-p</sub> by changing R<sub>REF</sub> to 3.4 kΩ. This may be done by removing the Output Level shorting jumper on the post header.

### Application Information (Continued)

The Test Out output is intended for monitoring by equipment having high impedance test loading (>500Ω). If the Lock

Detect output is to be externally monitored, the attached monitoring circuit should present a DC resistance greater than 5 kΩ so as not to affect Lock Detect indicator operation.

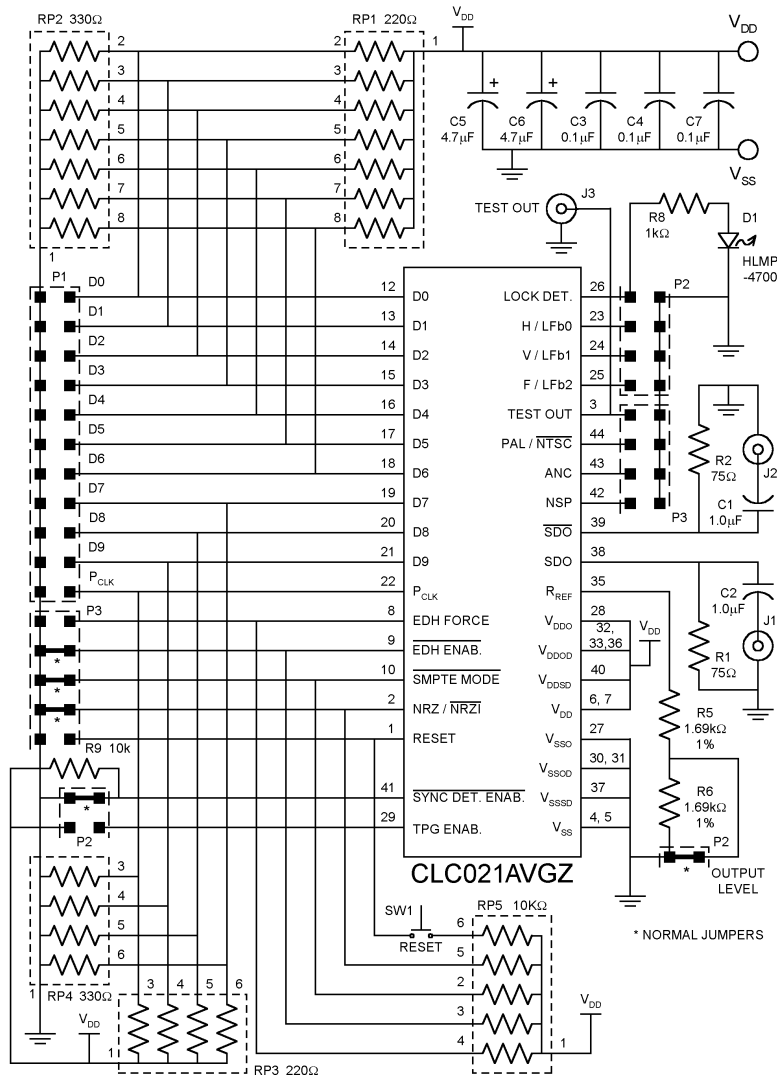

10136809

Connect LOCK DETECT to TPG ENABLE for test pattern generator function.  
 Remove RP1 & RP3 and replace RP2 & RP4 with 50Ω resistor packs for coax interfacing.  
 Install RP1-4 when using ribbon cable for input interfacing.  
 This board is designed for use with TTL power supplies only.

FIGURE 9. SD021EVK Schematic Diagram

### MEASURING JITTER

The test method used to obtain the timing jitter value given in the AC Electrical Specification table is based on procedures and equipment described in SMPTE RP 192-1996. The recommended practice discusses several methods and indicator devices. An FFT method performed by standard video test equipment was used to obtain the data given in this data sheet. As such, the jitter characteristics (or jitter floor) of the measurement equipment, particularly the measurement analyzer, become integral to the resulting jitter value. The

method and equipment were chosen so that the test can be easily duplicated by the design engineer using most standard digital video test equipment. In so doing, similar results should be achieved. The intrinsic jitter floor of the CLC021's PLL is approximately 25% of the typical jitter given in the electrical specifications. In production, device jitter is measured on automatic IC test equipment (ATE) using a different method compatible with that equipment. Jitter measured using this ATE yields values approximately 50% of those obtained using the video test equipment.

## Application Information (Continued)

The jitter test setup used to obtain values quoted in the data sheet consists of:

- National Semiconductor SD021-5EVK (SD021-3EVK), CLC021 evaluation kit
- Tektronix TG2000 signal generation platform with DVG-1 option
- Tektronix VM700T Option 1S Video Measurement Set
- Tektronix TDS 794D, Option C2 oscilloscope
- Tektronix P6339A passive probe
- 75Ω coaxial cable, 3 ft., Belden 8281 or RG59 (2 required)
- ECL-to-TTL/CMOS level converter/amplifier, (see Figure 11).

Apply the black-burst reference clock from the TG2000 signal generator's BG1 module 27 MHz clock output to the level converter input. The clock amplitude converter schematic is shown in Figure 11. Adjust the input bias control to give a 50% duty cycle output as measured on the oscilloscope/probe system. Connect the level translator to the SD021EVK board, connector P1, P<sub>CLK</sub> pins (the outer-most row of pins

is ground). Configure the SD021EVK to operate in the NTSC colour bars, BIST mode. Configure the VM700T to make the jitter measurement in the jitter FFT mode at the frame rate with 1 kHz filter bandwidth and Hanning window. Configure the setup as shown in Figure 10. Switch the test equipment on (from standby mode) and allow all equipment temperatures stabilize per manufacturer's recommendation. Measure the jitter value after allowing the instrument's reading to stabilize (about 1 minute). Consult the VM700T Video Measurement Set Option 1S Serial Digital Measurements User Manual (document number 071-0074-00) for details of equipment operation.

The VM700T measurement system's jitter floor specification at 270 Mbps is given as 200 ps ±20% (100 ps ±5% typical) of actual components from 50 Hz to 1 MHz and 200 ps +60%, -30% of actual components from 1 MHz to 10 MHz. To obtain the actual residual jitter of the CLC021, a root-sum-square adjustment of the jitter reading must be made to compensate for the measurement system's jitter floor specification. For example, if the jitter reading is 250 ps, the CLC021 residual jitter is the square root of  $(250^2 - 200^2) = 150$  ps. The accuracy limits of the reading as given above apply.

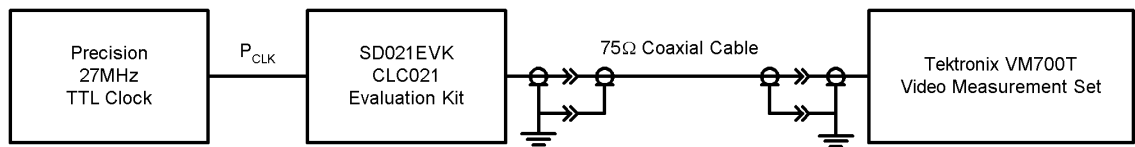

10136810

FIGURE 10. Jitter Test Circuit

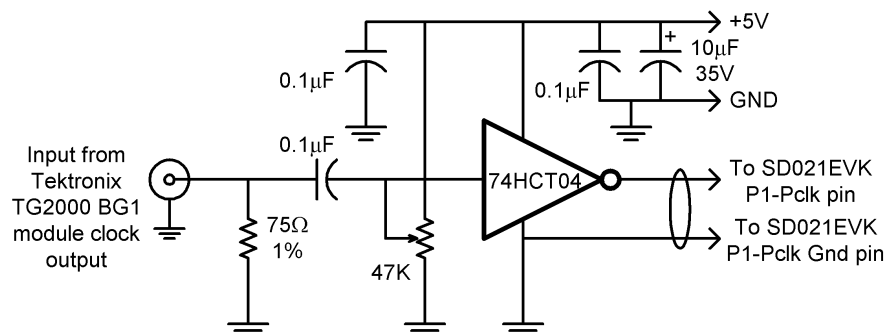

All resistances in Ohms.  
Ground all unused inputs.

10136813

FIGURE 11. ECL-to-TTL/CMOS Level Converter/Amplifier



## Application Information (Continued)

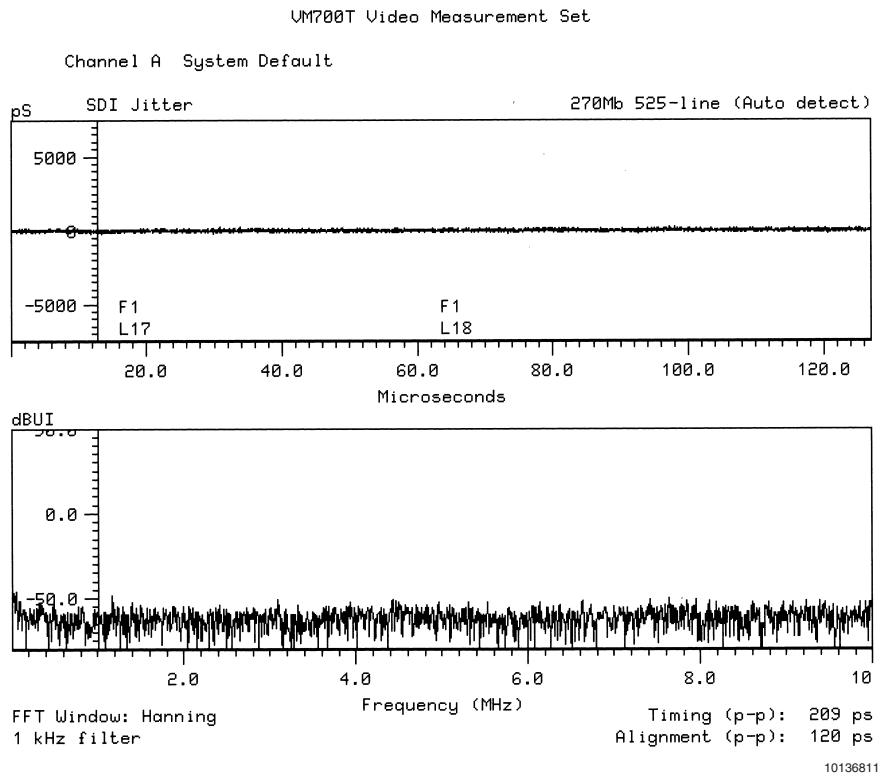

FIGURE 12. Jitter Plots

### PCB LAYOUT AND POWER SYSTEM BYPASS RECOMMENDATIONS

Circuit board layout and stack-up for the CLC021 should be designed to provide noise-free power to the device. Good layout practice also will separate high frequency or high level inputs and outputs to minimize unwanted stray noise pickup, feedback and interference. Power system performance may be greatly improved by using thin dielectrics (4 to 10 mils) for power/ground sandwiches. This increases the intrinsic capacitance of the PCB power system which improves power supply filtering, especially at high frequencies, and makes the value and placement of external bypass capacitors less critical. External bypass capacitors should include both RF ceramic and tantalum electrolytic types. RF capacitors may use values in the range 0.01  $\mu\text{F}$  to 0.1  $\mu\text{F}$ . Tantalum capacitors may be in the range 2.2  $\mu\text{F}$  to 10  $\mu\text{F}$ . Voltage rating for tantalum capacitors should be at least 5X the power supply voltage being used. It is recommended practice to use two vias at each power pin of the CLC021 as well as all RF bypass capacitor terminals. Dual vias reduce the interconnect inductance by up to half, thereby reducing interconnect inductance and extending the effective frequency range of the bypass components.

The outer layers of the PCB may be flooded with additional  $V_{SS}$  (ground) plane. These planes will improve shielding and isolation as well as increase the intrinsic capacitance of the power supply plane system. Naturally, to be effective, these

planes must be tied to the  $V_{SS}$  power supply plane at frequent intervals with vias. Frequent via placement also improves signal integrity on signal transmission lines by providing short paths for image currents which reduces signal distortion. The planes should be pulled back from all transmission lines and component mounting pads a distance equal to the width of the widest transmission line or the thickness of the dielectric separating the transmission line from the internal power or ground plane(s) whichever is greater. Doing so minimizes effects on transmission line impedances and reduces unwanted parasitic capacitances at component mounting pads.

In especially noisy power supply environments, such as is often the case when using switching power supplies, separate filtering may be used at the CLC021's VCO and output driver power pins. The CLC021 was designed for this situation. The digital section, VCO and output driver power supply feeds are independent (see pinout description table and pinout drawing for details). Supply filtering may take the form of L-section or pi-section, L-C filters in series with these  $V_{DD}$  inputs. Such filters are available in a single package from several manufacturers. Despite being independent feeds, all device power supplies should be applied simultaneously as from a common source. The CLC021 is free from power supply latch-up caused by circuit-induced delays between the device's three separate power feed systems.

**Physical Dimensions** inches (millimeters) unless otherwise noted

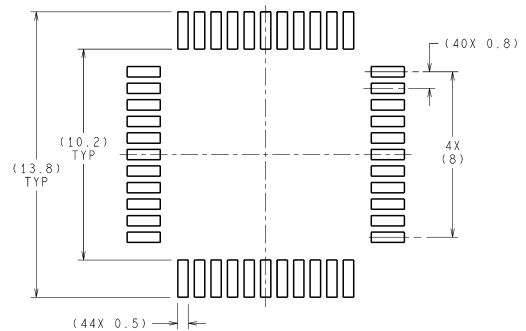
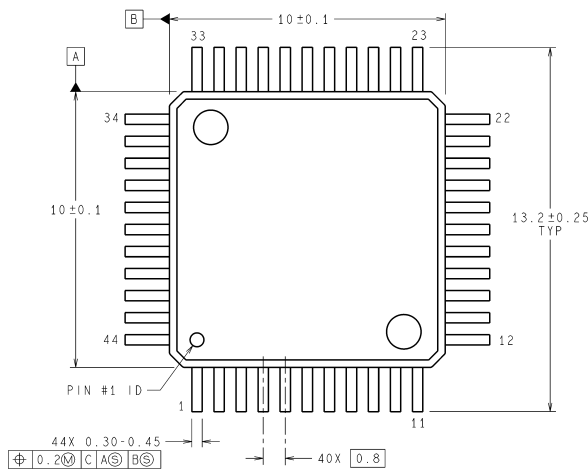

RECOMMENDED LAND PATTERN

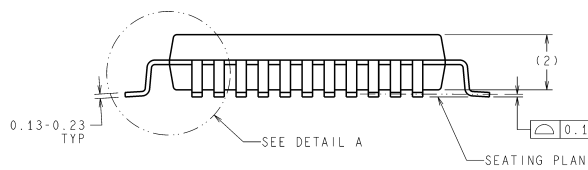

DIMENSIONS ARE IN MILLIMETERS

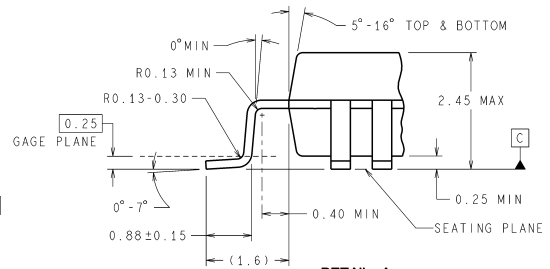

DETAIL A TYPICAL

VGZ44A (Rev E)

**44-Pin Metric PQFP**  
**Order Number CLC021AVGZ-5.0 or CLC21AVGZ-3.3**  
**NS Package Number VGZ44A**

**LIFE SUPPORT POLICY**

NATIONAL'S PRODUCTS ARE NOT AUTHORIZED FOR USE AS CRITICAL COMPONENTS IN LIFE SUPPORT DEVICES OR SYSTEMS WITHOUT THE EXPRESS WRITTEN APPROVAL OF THE PRESIDENT AND GENERAL COUNSEL OF NATIONAL SEMICONDUCTOR CORPORATION. As used herein:

1. Life support devices or systems are devices or systems which, (a) are intended for surgical implant into the body, or (b) support or sustain life, and whose failure to perform when properly used in accordance with instructions for use provided in the labeling, can be reasonably expected to result in a significant injury to the user.
2. A critical component is any component of a life support device or system whose failure to perform can be reasonably expected to cause the failure of the life support device or system, or to affect its safety or effectiveness.

**National Semiconductor**  
**Americas Customer**  
**Support Center**  
 Email: new.feedback@nsc.com  
 Tel: 1-800-272-9959  
 www.national.com

**National Semiconductor**  
**Europe Customer Support Center**  
 Fax: +49 (0) 180-530 85 86  
 Email: europe.support@nsc.com  
 Deutsch Tel: +49 (0) 69 9508 6208  
 English Tel: +44 (0) 870 24 0 2171  
 Français Tel: +33 (0) 1 41 91 8790

**National Semiconductor**  
**Asia Pacific Customer**  
**Support Center**  
 Email: ap.support@nsc.com

**National Semiconductor**  
**Japan Customer Support Center**  
 Fax: 81-3-5639-7507  
 Email: jpn.feedback@nsc.com  
 Tel: 81-3-5639-7560