

# DS90CP04

## 4x4 Low Power 2.5 Gb/s LVDS Digital Cross-Point Switch

### General Description

DS90CP04 is a 4x4 digital cross-point switch with broadside input and output pins for efficient board layout. It utilizes Low Voltage Differential Swing (LVDS) technology for low power, high-speed operation. Data paths are fully differential from input to output for low noise. The non-blocking architecture allows connections of any input to any output or outputs. The switch matrix consists of four differential 4:1 multiplexers. Each output channel connects to one of the four inputs common to all multiplexers. Each DS90CP04 output pair is capable of independent operation up to 2.5Gb/s.

A simple serial control interface or a configuration select port is activated by the state of the MODE pin. When utilizing the serial control interface a single load command will update the new switch configuration for all outputs simultaneously. When the direct configuration port is used, output configurations are updated immediately based on the decoded SEL0/1 logic state.

### Features

- 2.5 Gbps fully differential data paths
- Non-blocking architecture
- Broadcast from any input
- Broadside pin-out
- Possible expansion to larger switch array
- Accepts LVDS/BLVDS/LVPECL/2.5V-CML inputs
- TRI-STATE LVDS outputs
- Serial control interface with read-back capability
- Double register loading
- Single +2.5V supply
- Low power, 575 mW Typ at 2.5 Gb/s
- Lead-less LLP-32 package 6x6 mm body size)
- Fabricated with advanced CMOS process technology

### Functional Block Diagrams

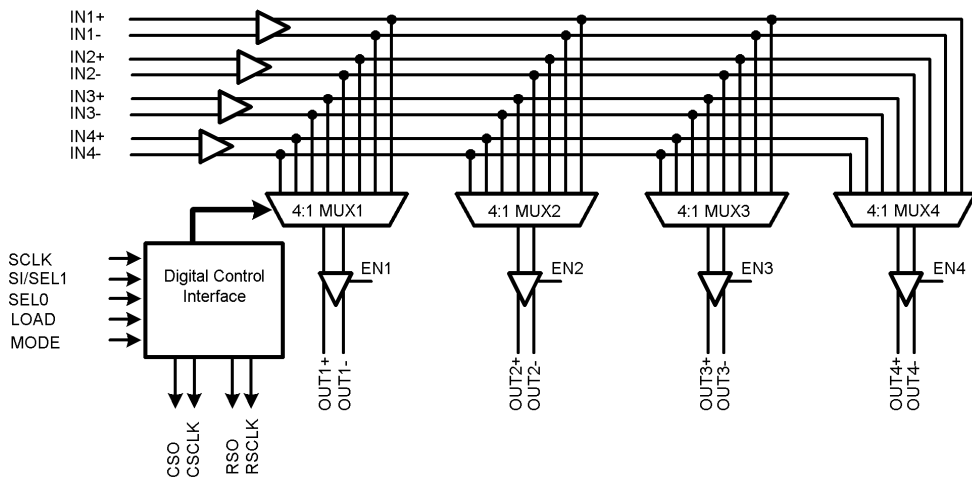

20028701

**Functional Block Diagrams** (Continued)

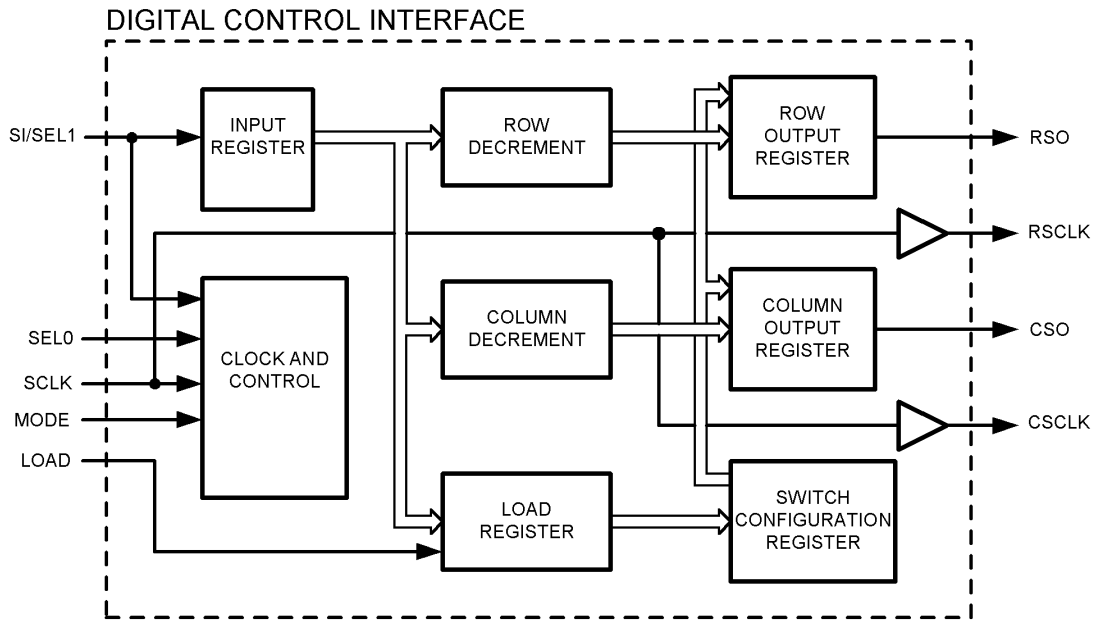

20028702

# Connection Diagram

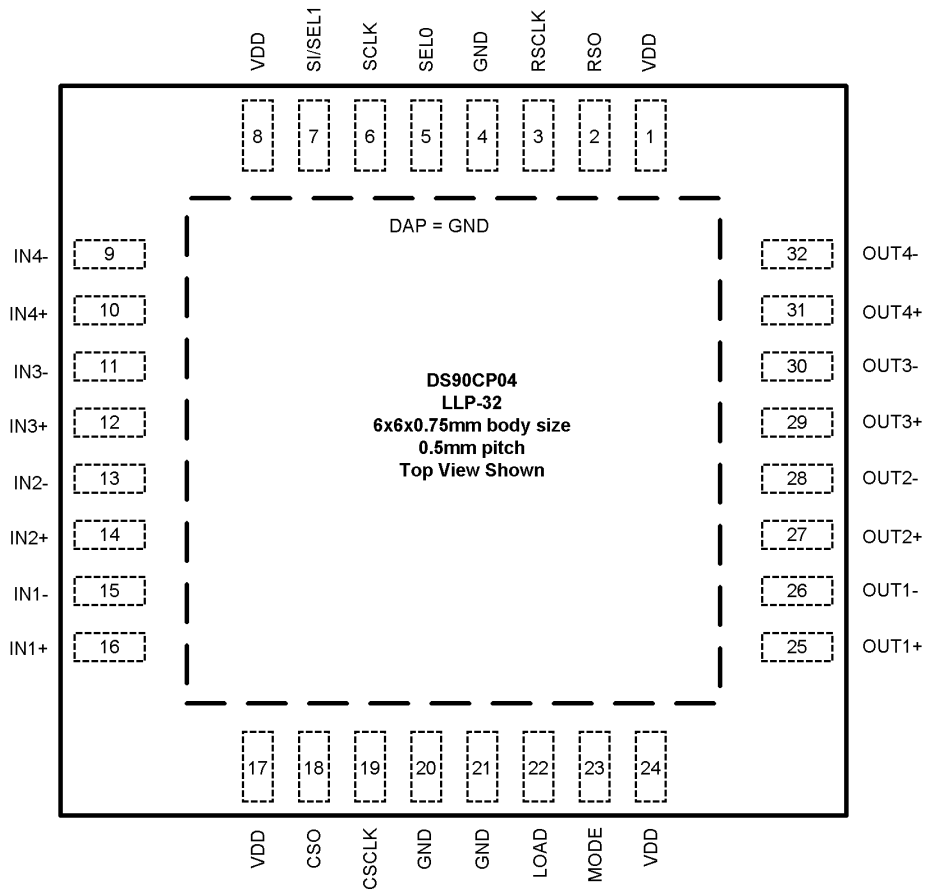

Order Number DS90CP04TLQ, DS90CP04TLQX (Tape and Reel)  
See NS Package Number LQA32A

20028703

Pin Descriptions			
Pin Name	Pin Number	I/O, Type	Description
<b>DIFFERENTIAL INPUTS COMMON TO ALL MUXES</b>			
IN1+	16	I, LVDS	Inverting and non-inverting differential inputs.
IN1-	15		
IN2+	14	I, LVDS	Inverting and non-inverting differential inputs.
IN2-	13		
IN3+	12	I, LVDS	Inverting and non-inverting differential inputs.
IN3-	11		
IN4+	10	I, LVDS	Inverting and non-inverting differential inputs.
IN4-	9		
<b>SWITCHED DIFFERENTIAL OUTPUTS</b>			
OUT1+	25	O, LVDS	Inverting and non-inverting differential outputs. OUT1± can be connected to any one pair IN1±, IN2±, IN3±, or IN4±
OUT1-	26		
OUT2+	27	O, LVDS	Inverting and non-inverting differential outputs. OUT2± can be connected to any one pair IN1±, IN2±, IN3±, or IN4±
OUT2-	28		
OUT3+	29	O, LVDS	Inverting and non-inverting differential outputs. OUT3± can be connected to any one pair IN1±, IN2±, IN3±, or IN4
OUT3-	30		
OUT4+	31	O, LVDS	Inverting and non-inverting differential outputs. OUT4± can be connected to any one pair IN1±, IN2±, IN3±, or IN4±
OUT4-	32		
<b>DIGITAL CONTROL INTERFACE</b>			
SCLK	6	I, LVCMOS	Control clock to latch in programming data at SI. SCLK can be 0 MHz to 100 MHz. SCLK should be burst of clock pulses active only while accessing the device. After completion of programming, SCLK should be kept at logic low to minimize potential noise injection into the high-speed differential data paths.
SI / SEL1	7	I, LVCMOS	Programming data to select the switch configuration. Data is latched into the input buffer register at the rising edge of SCLK.
SEL0	5	I, LVCMOS	Programming data to select the switch configuration.
CSO RSO	18 2	O, LVCMOS	With MODE low, control data is shifted out at CSO (RSO) for cascading to the next device in the serial chain. The control data at CSO (RSO) is identical to that shifted in at SI with the exception of the device column (row) address being decremented by one internally before propagating to the next device in the chain. CSO (RSO) is clocked out at the rising edge of SCLK.
CSCLK RSCLK	19 3	O, LVCMOS	With MODE low, these pins function as a buffered control clock from SCLK. CSCLK (RSCLK) is used for cascading the serial control bus to the next device in the serial chain.
LOAD	22	I, LVCMOS	When LOAD is high and SCLK makes a LH transition, the device transfers the programming data in the load register into the configuration registers. The new switch configuration for all outputs takes effect. LOAD needs to remain high for only one SCLK cycle to complete the process, holding LOAD high longer repeats the transfer to the configuration register.
MODE	23	I, LVCMOS	When MODE is low, the SCLK is active and a buffered SCLK signal is present at the CLKOUT output. When MODE is high, the SCLK signal is uncoupled from register and state machine internals. Internal registers will see an active low signal until MODE is brought Low again.
<b>POWER</b>			
V <sub>DD</sub>	1, 8, 17, 24	I, Power	V <sub>DD</sub> = 2.5V ±5%. At least 4 low ESR 0.01 μF bypass capacitors should be connected from V <sub>DD</sub> to GND plane.
GND	4, 20, 21, DAP	I, Power	Ground reference to LVDS and CMOS circuitry. DAP is the exposed metal contact at the bottom of the LPP-32 package. The DAP is used as the primary GND connection to the device. It should be connected to the ground plane with at least 4 vias for optimal AC and thermal performance.

## Serial Interface Truth Table

LOAD	MODE	SCLK	Resulting Action
0	0	LH	The current state on SI is clocked into the input shift register.
0	1	LH	Uncouples SCLK input from register and state machine internals. Internal registers will see and the RSCLK and CSCLK outputs will drive an active Low signal until MODE is brought Low again. See Configuration Select Truth Table below.
LH	0	X	Loads OUT1–OUT4 configuration information from last valid frame. Places contents of load register into the configuration register. The switch configuration is updated asynchronously from the SCLK input.
1	1	LH	Uncouples SCLK input from register and state machine internals. Internal registers will see and the RSCLK and CSCLK outputs will drive an active Low signal until MODE is brought Low again. See Configuration Select Truth Table below.

## Configuration Select Truth Table

MODE	SEL1	SEL0	Resulting Action
0	X	X	The SEL0/1 pins only function in configuration select mode. See below.
1	0	0	Distribution: IN1 - OUT1 OUT2 OUT3 OUT4
1	0	1	Distribution: IN2 - OUT1 OUT2 OUT3 OUT4
1	1	0	Redundancy: IN1 - OUT1 OUT2 and IN3 - OUT3 OUT4
1	1	1	Broadside: IN1 - OUT1, IN2 - OUT2, IN3 - OUT3, IN4 - OUT4

LH: Low to High (positive edge) transition.

X: Don't Care or Not Applicable.

**Configuration Select Truth Table** (Continued)

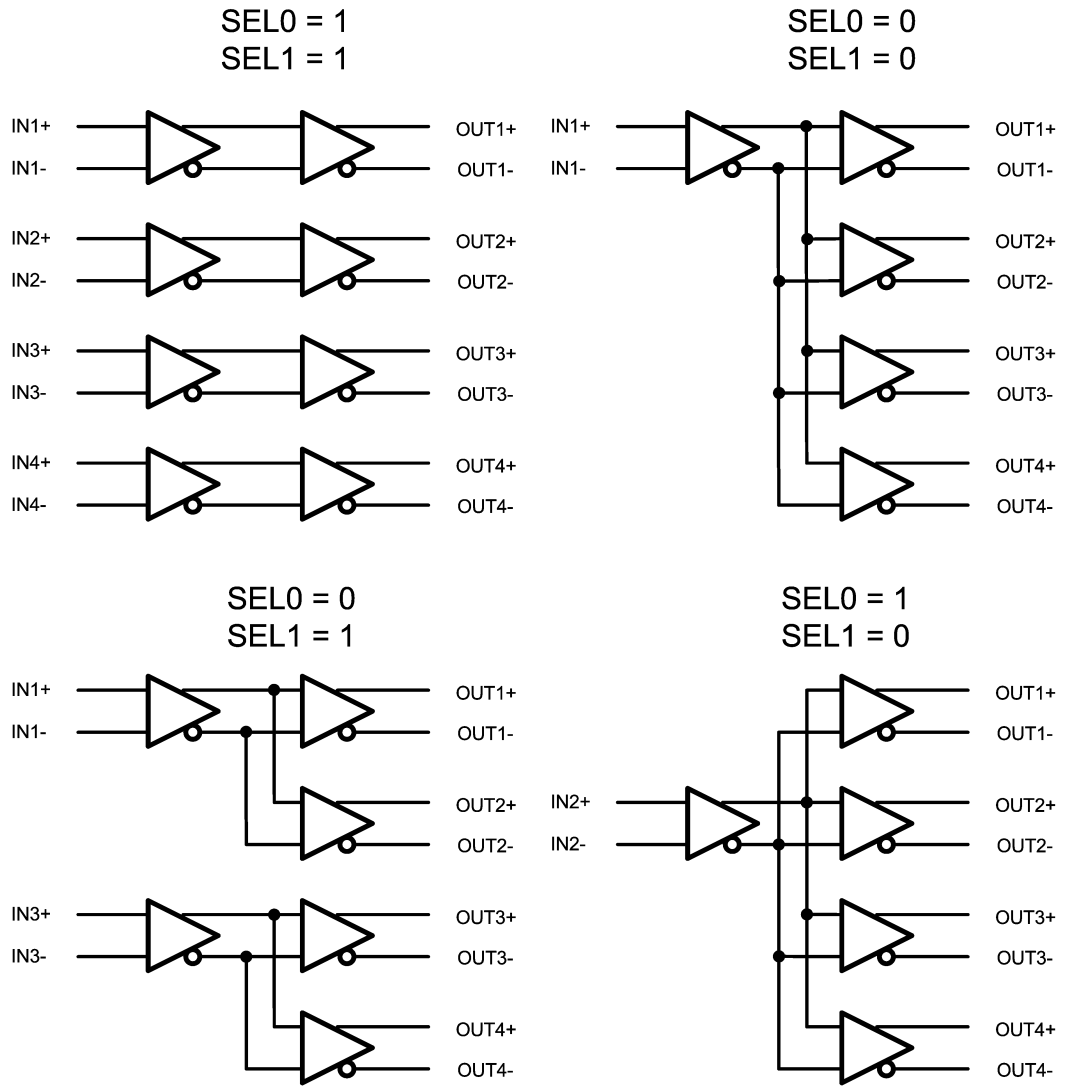

20028704

**FIGURE 1. DS90CP04 Configuration Select Decode**

**Absolute Maximum Ratings** (Note 1)

If Military/Aerospace specified devices are required, please contact the National Semiconductor Sales Office/Distributors for availability and specifications.

Supply Voltage ( $V_{DD}$ )	-0.3V to +3V
CMOS/TTL Input Voltage	-0.3V to ( $V_{DD}$ +0.3V)
LVDS Receiver Input Voltage	-0.3V to +3.3V
LVDS Driver Output Voltage	-0.3V to +3V
LVDS Output Short Circuit Current	40mA
Junction Temperature	+150°C
Storage Temperature	-65°C to +150°C
Lead Temperature (Soldering, 4 sec.)	+260°C
Maximum Package Power Dissipation at 25°C	
LLP-32	3200 mW
Derating above 25°C	38 mW/°C

Thermal Resistance, $\theta_{JA}$	26.4°C/W
ESD Rating	
HBM, 1.5 k $\Omega$ , 100 pF	
LVDS Outputs	>1.0 kV
LVDS Inputs	>1.5 kV
All Other Pins	>4.0 kV
EIAJ, 0 $\Omega$ , 200 pF	>100V

**Recommended Operating Conditions**

	Min	Typ	Max	Unit
Supply Voltage ( $V_{DD}$ - GND)	2.375	2.5	2.625	V
Receiver Input Voltage	0.05		3.3	V
Operating Free Air Temperature	-40	25	85	°C
Junction Temperature			110	°C

**Electrical Characteristics**

Over recommended operating supply and temperature ranges unless other specified.

Symbol	Parameter	Conditions	Min	Typ (Note 2)	Max	Units
<b>LVCMOS/LVTTL DC SPECIFICATIONS</b> (SCLK, SI/SEL1, SEL0, LOAD, MODE, CCLK, RSCLK, CSO, RSO)						
$V_{IH}$	High Level Input Voltage		1.7		$V_{DD}$	V
$V_{IL}$	Low Level Input Voltage		GND		0.7	V
$I_{IH}$	High Level Input Current	$V_{IN} = V_{DD} = V_{DDMAX}$	-10		+10	$\mu$ A
$I_{IL}$	Low Level Input Current	$V_{IN} = V_{SS}, V_{DD} = V_{DDMAX}$	-10		+10	$\mu$ A
$C_{IN1}$	Input Capacitance	Any Digital Input Pin to $V_{SS}$		3.5		pF
$C_{OUT1}$	Output Capacitance	Any Digital Output Pin to $V_{SS}$		5.5		pF
$V_{CL}$	Input Clamp Voltage	$I_{CL} = -18$ mA	-1.5	-0.8		V
$V_{OH}$	High Level Output Voltage	$I_{OH} = -4.0$ mA, $V_{DD} = V_{DDMIN}$	1.9			V
		$I_{OH} = -100$ $\mu$ A, $V_{DD} = 2.5$ V	2.4			V
$V_{OL}$	Low Level Output Voltage	$I_{OL} = 4.0$ mA, $V_{DD} = V_{DDMIN}$			0.4	V
		$I_{OL} = 100$ $\mu$ A, $V_{DD} = 2.5$ V			0.1	V
<b>LVDS INPUT DC SPECIFICATIONS</b> (IN1 $\pm$ , IN2 $\pm$ , IN3 $\pm$ , IN4 $\pm$ )						
$V_{TH}$	Differential Input High Threshold (Note 3)	$V_{CM} = 0.05$ V or 1.2V or 2.45V, $V_{DD} = 2.5$ V		0	50	mV
$V_{TL}$	Differential Input Low Threshold	$V_{CM} = 0.05$ V or 1.2V or 2.45V, $V_{DD} = 2.5$ V	-50	0		mV
$V_{ID}$	Differential Input Voltage	$V_{DD} = 2.5$ V, $V_{CM} = 0.05$ V to 2.45V	100		$V_{DD}$	mV
$V_{CMR}$	Common Mode Voltage Range	$V_{ID} = 100$ mV, $V_{DD} = 2.5$ V	0.05		3.25	V
$C_{IN2}$	Input Capacitance	IN+ or IN- to $V_{SS}$		3.5		pF
$I_{IN}$	Input Current	$V_{IN} = 2.5$ V, $V_{DD} = V_{DDMAX}$ or 0V	-10		+10	$\mu$ A
		$V_{IN} = 0$ V, $V_{DD} = V_{DDMAX}$ or 0V	-10		+10	$\mu$ A
<b>LVDS OUTPUT DC SPECIFICATIONS</b> (OUT1 $\pm$ , OUT2 $\pm$ , OUT3 $\pm$ , OUT4 $\pm$ )						
$V_{OD}$	Differential Output Voltage (Note 3)	$R_L = 100\Omega$ between OUT+ and OUT- <i>Figure 2</i>	250	400	475	mV
$\Delta V_{OD}$	Change in $V_{OD}$ between Complementary States		-35		35	mV
$V_{OS}$	Offset Voltage (Note 4)		1.125	1.25	1.375	V
$\Delta V_{OS}$	Change in $V_{OS}$ between Complementary States		-35		35	mV

**Electrical Characteristics** (Continued)

Over recommended operating supply and temperature ranges unless other specified.

Symbol	Parameter	Conditions	Min	Typ (Note 2)	Max	Units	
$I_{OZ}$	Output TRI-STATE Current	TRI-STATE Output $V_{OUT} = V_{DD}$ or $V_{SS}$	-10		+10	$\mu A$	
$I_{OFF}$	Power Off Leakage Current	$V_{DD} = 0V$ , $V_{OUT} = 2.5V$ or GND	-10		+10	$\mu A$	
$I_{OS}$	Output Short Circuit Current, One Complementary Output	OUT+ or OUT- Short to GND		-15	-40	mA	
		OUT+ or OUT- Short to $V_{DD}$		15	40	mA	
$I_{OSB}$	Output Short Circuit Current, both Complementary Outputs	OUT+ and OUT- Short to GND		-15	-30	mA	
		OUT+ and OUT- Short to $V_{CM}$		15	30	mA	
$C_{OUT2}$	Output Capacitance	OUT+ or OUT- to GND when TRI-STATE		5.5		pF	
<b>SUPPLY CURRENT</b>							
$I_{CCD}$	Total Supply Current	All inputs and outputs enabled, terminated with differential load of $100\Omega$ between OUT+ and OUT-.		220	300	mA	
$I_{CCZ}$	TRI-STATE Supply Current	TRI-STATE All Outputs		10	20	mA	
<b>SWITCHING CHARACTERISTICS — LVDS OUTPUTS</b> (Figures 3, 5, 6)							
$t_{LHT}$	Differential Low to High Transition Time	Use an alternating 1 and 0 pattern at 200 Mb/s, measure between 20% and 80% of $V_{OD}$ .	100	135	160	ps	
$t_{HLT}$	Differential High to Low Transition Time		100	135	160	ps	
$t_{PLHD}$	Differential Low to High Propagation Delay	Use an alternating 1 and 0 pattern at 200 Mb/s, measure at 50% $V_{OD}$ between input to output.	500	750	1200	ps	
$t_{PHLD}$	Differential High to Low Propagation Delay		500	750	1200	ps	
$t_{SKD1}$	Pulse Skew	$ t_{PLHD} - t_{PHLD} $		0	30	ps	
$t_{SKCC}$	Output Channel to Channel Skew	Difference in propagation delay ( $t_{PLHD}$ or $t_{PHLD}$ ) among all output channels in Broadcast mode (any one input to all outputs).	0	50	100	ps	
$t_{JIT}$	Jitter (Note 5)	Alternating 1 and 0 Pattern	750 MHz	1.6	2.5	psrms	
			1.25 GHz	1.6	2.5	psrms	
			K28.5 Pattern	1.5 Gb/s	10	40	psp-p
				2.5 Gb/s	27	60	psp-p
			PRBS $2^{23}-1$ Pattern	1.5 Gb/s	25	40	psp-p
				2.5 Gb/s	40	70	psp-p
$t_{ON}$	LVDS Output Enable Time	Time from LOAD = LH or SELx to OUT $\pm$ change from TRI-STATE to active.	50	150	300	ns	
$t_{OFF}$	LVDS Output Disable Time	Time from LOAD = LH or SELx to OUT $\pm$ change from active to TRI-STATE.		3	5	ns	
$t_{SW}$	LVDS Switching Time	Time from LOAD = LH to new switch configuration effective for OUT $\pm$ .		50	150	ns	



## Electrical Characteristics (Continued)

Over recommended operating supply and temperature ranges unless other specified.

Symbol	Parameter	Conditions	Min	Typ (Note 2)	Max	Units
$t_{SEL}$	SELX to OUT $\pm$	Configuration select to new data at OUT $\pm$ .		50	150	ns
<b>SWITCHING CHARACTERISTICS — Serial control Interface (Figures 4, 8, 9)</b>						
$F_{SCLK}$	SCLK Clock Frequency		0		100	MHz
$T_{DCCLK}$	CSCLK Duty Cycle RSCLK Duty Cycle	Input SCLK Duty Cycle set at 50%	45		55	%
$t_S$	SI–SCLK or MODE–SCLK Setup Time	From SI or MODE Input Data to SCLK Rising Edge	1.5			ns
$t_H$	SCLK–SI or SCLK–MODE Hold Time	From SCLK Rising Edge to SI or MODE Input Data	1			ns
$t_{DSO}$	SCLK to RSO or CSO Delay	From SCLK to RSO or CSO	1.5		4	ns
$t_{DSCLK}$	SCLK to RSCLK or CSCLK Delay	From SCLK to RSCLK or CSCLK	4.0		8.5	ns
$t_{DSDIF}$	ISCLK to RSCLK or CSCLK–SCLK to RSO or CSOI	Propagation Delay Difference between $t_{DSO}$ and $t_{DSCLK}$	1.5		4.5	ns
$T_{RISE}$	Logic Low to High Transition Time	20% to 80% at RSO, CSO, RSCLK, or CSCLK		1.5		ns
$T_{FALL}$	Logic High to Low Transition Time	80% to 20% at RSO, CSO, RSCLK, or CSCLK		1.5		ns

**Note 1:** “Absolute Maximum Ratings” are the ratings beyond which the safety of the device cannot be guaranteed. They are not meant to imply that the device should be operated at these limits.

**Note 2:** Typical parameters are measured at  $V_{DD} = 2.5V$ ,  $T_A = 25^\circ C$ . They are for reference purposes, and are not production-tested.

**Note 3:** Differential output voltage  $V_{OD}$  is defined as  $I_{OUT+} - I_{OUT-}$ . Differential input voltage  $V_{ID}$  is defined as  $I_{IN+} - I_{IN-}$ .

**Note 4:** Output offset voltage  $V_{OS}$  is defined as the average of the LVDS single-ended output voltages at logic high and logic low states.

**Note 5:** Characterized from any input to any one differential LVDS output running at the specified data rate and data pattern, with all other 3 channels running K28.5 pattern at 1.25 Gb/s asynchronously to the channel under test. Jitter is not production-tested, but guaranteed through characterization on sample basis. Random Jitter is measured peak to peak with a histogram including 1000 histogram window hits. K28.5 pattern is repeating bit streams of (0011111010 1100000101). This deterministic jitter or DJ pattern is measured to a histogram mean with a sample size of 350 hits. Like RJ the Total Jitter or TJ is measured peak to peak with a histogram including 3500 window hits.

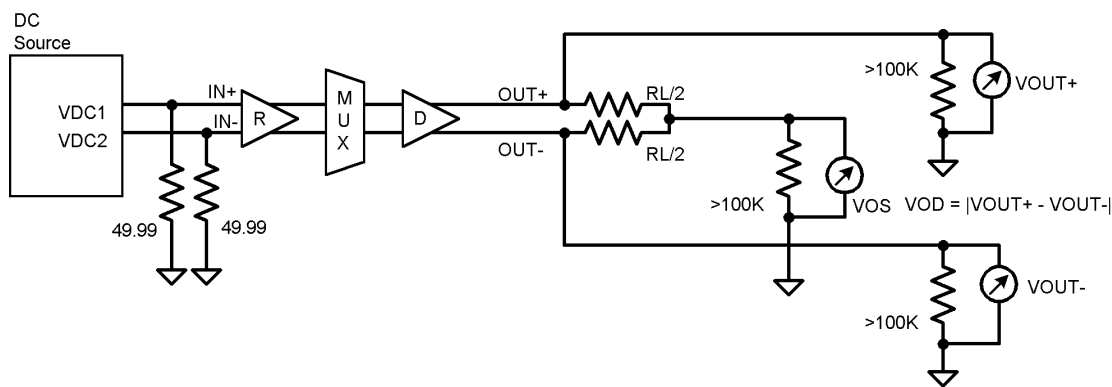
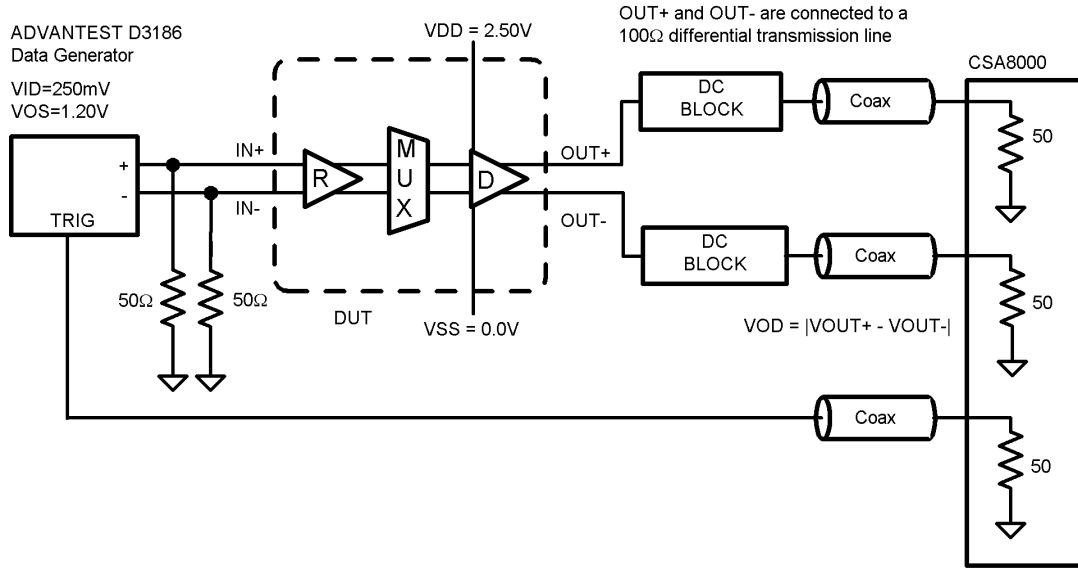

FIGURE 2. Differential Driver DC Test Circuit

Electrical Characteristics (Continued)



20028713

FIGURE 3. Differential Driver AC Test Circuit

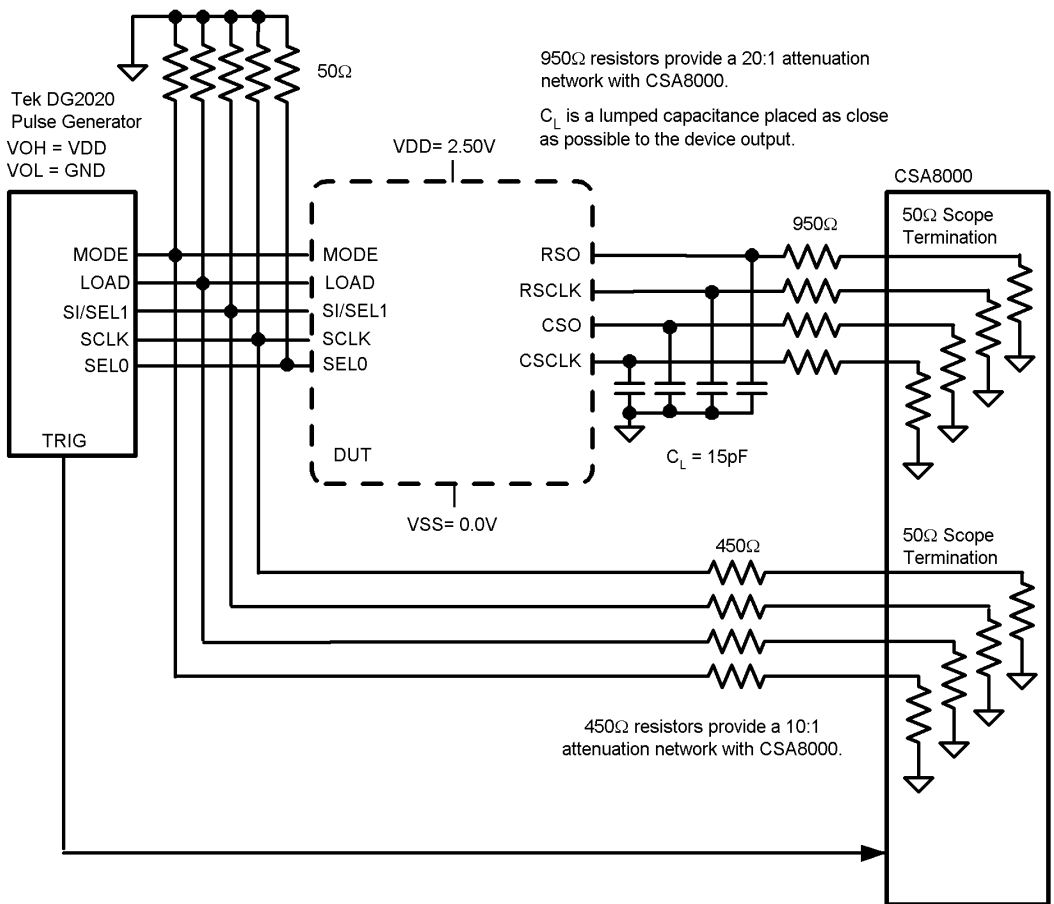

20028714

FIGURE 4. LVCMOS Driver AC Test Circuit (Note 6)

## Electrical Characteristics (Continued)

**Note 6:** The LVCMOS input and output AC specifications may also be verified and tested using an input attenuation network instead of a power splitter as shown in Figure 4.

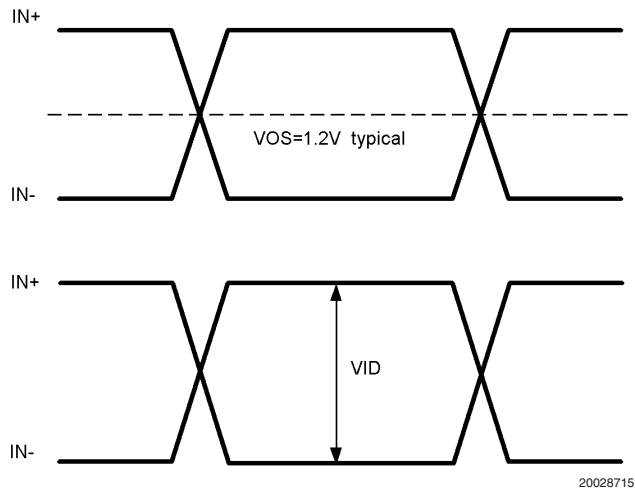

FIGURE 5. LVDS Signals

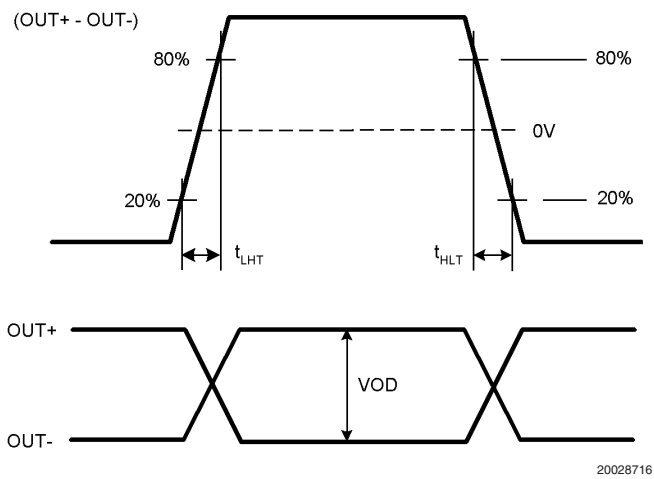

FIGURE 6. LVDS Output Transition Time

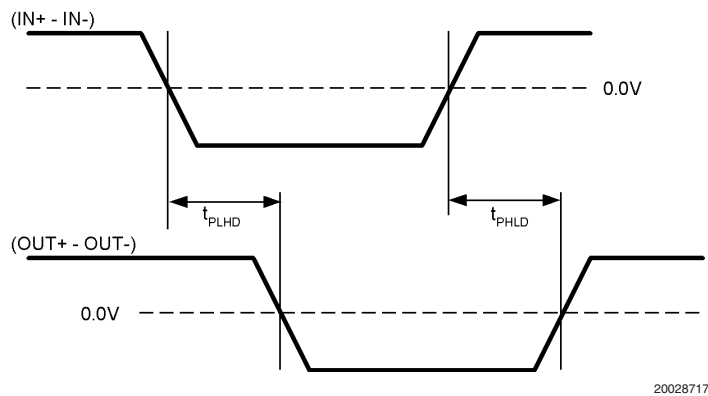
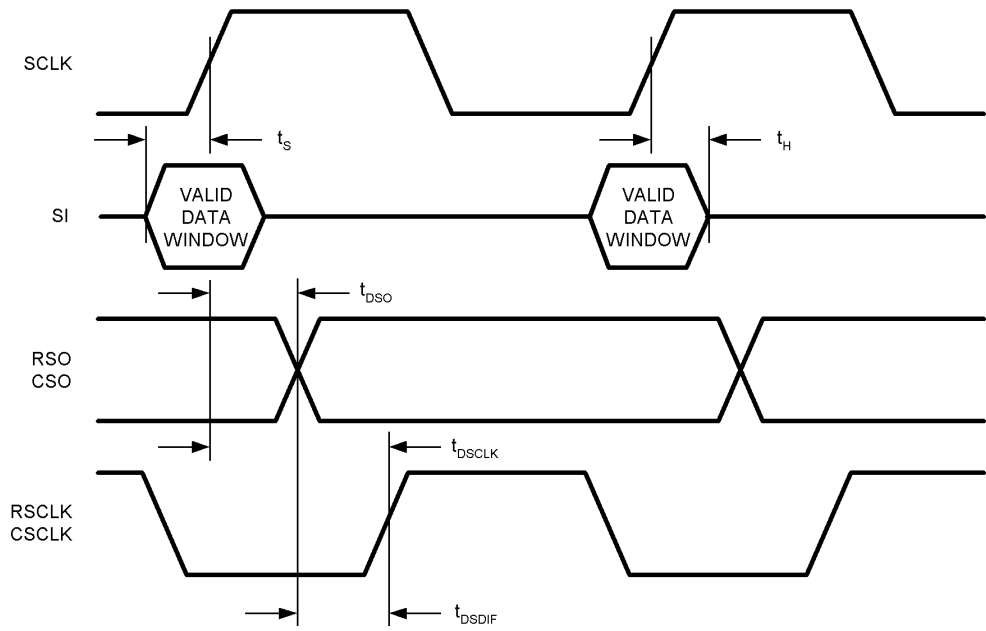
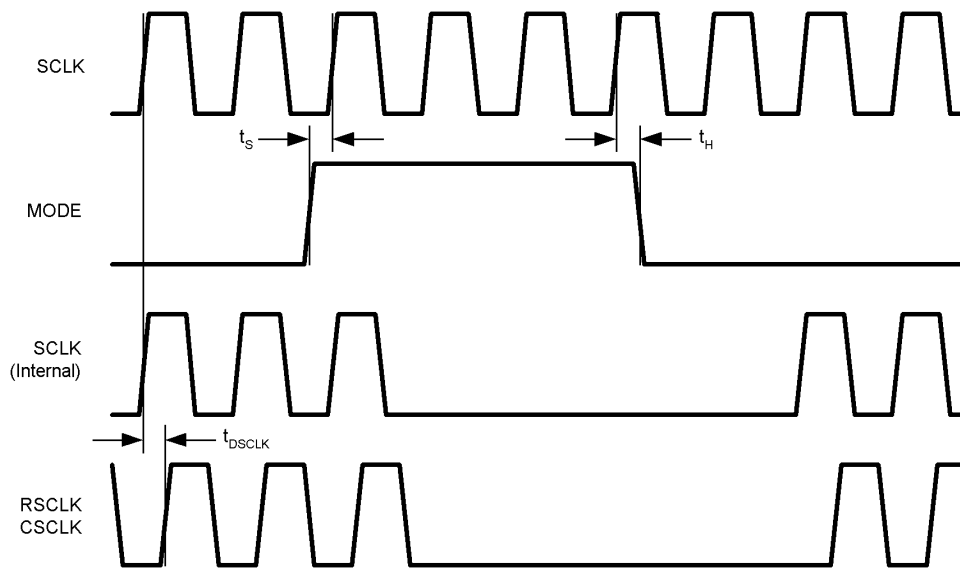

FIGURE 7. LVDS Output Propagation Delay



20028718

FIGURE 8. Serial Interface Propagation Delay and Input Timing Waveforms



20028719

FIGURE 9. Serial Interface — MODE Timing and Functionality

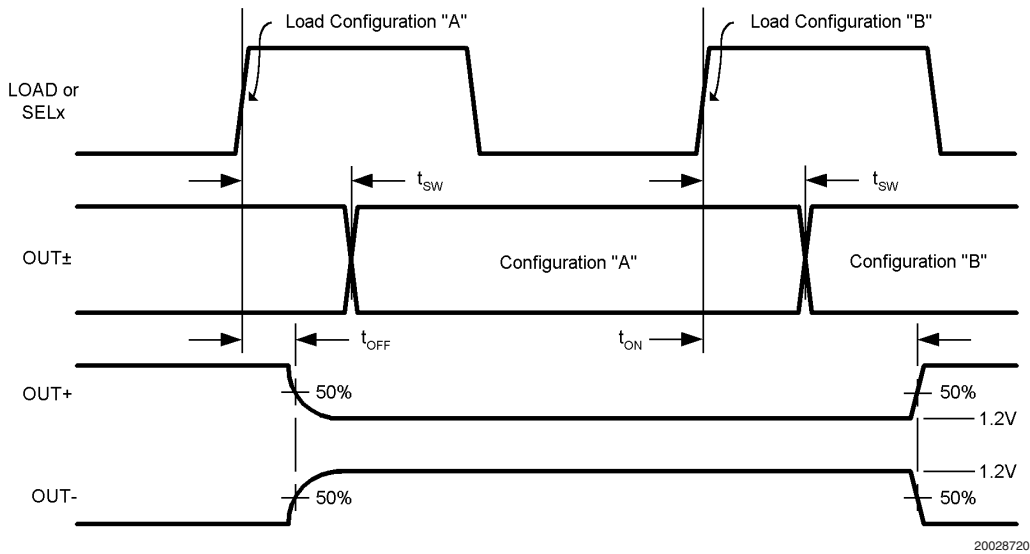

FIGURE 10. Configuration and Output Enable/Disable Timing

## Functional Descriptions

### PROGRAMMING WITH THE SERIAL INTERFACE

The configuration of the internal multiplexer is programmed through a simple serial interface consisting of serial clock SCLK and serial input data line SI. The serial interface is designed for easy expansion to larger switch array. A replicated output serial interface (RSCLK, RSO) is provided for propagating the control data to the downstream device in the row of an array of DS90CP04 devices in a matrix. A similar replicated serial interface (CSCLK, CSO) is provided for propagating the control data to the downstream devices in the first column of the device matrix. Through this scheme, user can program all the devices in the matrix through one

serial control bus (SCLK and SI) with the use of the feed-through replicated control bus at RSCLK and RSO, CSCLK and CSO.

To program the configuration of the switch, a 30-bit control word is sent to the device. The first 6 bits shift the start frame into SI. The only two valid start frames are 1F'h for a configuration load and 1E'h for a configuration read. The start frame is followed by the row and column addresses of the device to be accessed, as well as the switch configuration of the four channels of the device. *Table 1* and *Table 2* are the bit definitions of the control word. D29 is the first bit that shifts into SI.

TABLE 1. 30-Bit Control Word

Bit	Bit Length	Descriptions
D29–D24	6	The start frame for control word synchronization (01 1111'b = LOAD).
D23–D18	6	Specify the row address of the device to be access. The serial interface can access up to 64 devices in the row.
D17–D12	6	Specify the column address of the device to be access. The serial interface can access up to 64 devices in the column.
D11–D9	3	Specify the switch configuration for Output 1. See <i>Table 2</i> .
D8–D6	3	Specify the switch configuration for Output 2. See <i>Table 2</i> .
D5–D3	3	Specify the switch configuration for Output 3. See <i>Table 2</i> .
D2–D0	3	Specify the switch configuration for Output 4. See <i>Table 2</i> .

TABLE 2. Switch Configuration Data

MSB		LSB	OUT1± Connects to	OUT2± Connects to	OUT3± Connects to	OUT4± Connects to
0	0	0	Output 1 Tri-Stated	Output 2 Tri-Stated	Output 3 Tri-Stated	Output 4 Tri-Stated
0	0	1	IN1±	IN1±	IN1±	IN1±
0	1	0	IN2±	IN2±	IN2±	IN2±
0	1	1	IN3±	IN3±	IN3±	IN3±
1	0	0	IN4±	IN4±	IN4±	IN4±
1	0	1	Invalid.			

## Functional Descriptions (Continued)

**TABLE 2. Switch Configuration Data (Continued)**

MSB		LSB	OUT1± Connects to	OUT2± Connects to	OUT3± Connects to	OUT4± Connects to
1	1	0	Use of these invalid combinations may cause loss of synchronization.			
1	1	1				

### ROW AND COLUMN ADDRESSING

The upper left device in an array of NxN devices is assigned row address 0, and column address 0. The devices to its right have column addresses of 1 to N, whereas devices below it have row addresses of 1 to N. The Serial Control Interface (SCLK and SI) is connected to the first device with the row and column addresses of 0. The Serial Control Interface shifts in a control word containing the row and column address of the device it wants to access. When the control data propagates through each device, the control word's address is internally decremented by one before it is sent to the next row or column device. When the control data is sent out the column interface (CSO and CSCLK) the row address is decremented by one. Similarly, when the column address data is shifted out the row interface (RSO and RSCLK) the column address is decremented by one. By the time the control word reaches the device it has been intended to program, both the row and column addresses have been decremented to 0.

Each device constantly checks for the receipt of a frame start (D29-24=01 1111'b or 01 1110'b). When it detects the proper start frame string, and the row and column addresses it receives are both 0, the device responds by storing the switch configuration data of the 30-bit control word into its load register.

Each device in the array is sequentially programmed through the serial interface. When programming is completed for the entire array, LOAD is pulsed high and the load register's content is transferred to the configuration register of each device. The LOAD pulse must wait until the final bit of the control word has been placed into the "load" register. This timing is guaranteed to take place two clock cycles after programming has been completed.

Due to internal shift registers additional SCLK cycles will be necessary to complete array programming. It takes 7 clock (SCLK) positive edge transitions for the control data to appear at RSO and CSO for its near neighbor. Users must provide the correct number of clock transitions for the control

data word to reach its destination in the array. *Table 3* shows an example of the control data words for a 4 device serial chain with connections (OUT1=IN1, OUT2=IN2, OUT16=IN16). To program the array, it requires four 30-bit control words to ripple through the serial chain and reach their destinations. In order to completely program the array in the 120 clock cycles associated with the 30-bit control words it is important to program the last device in the chain first. The following programming data pushes the initial data through the chain into the correct devices.

### READ-BACK SWITCH CONFIGURATION

The DS90CP04 is put into read-back mode by sending a special "Read" start frame (01 1110'b). Upon receipt of the special read start frame the configuration register information is transferred into the shift register and output at both RSO and CSO in the OUT1 to OUT4 bit segments of the read control word. Each time the read-back data from a device passes through its downstream device, its default address (11 1111'b) is internally decremented by one. The "relative" column address emerges at RSO of the last device in the row and is used to determine (11 1111'b - N) the column of the sending device. Similarly, the row address emerges at CSO of the sending device. After inserting the channel configuration information in the "read" control word, the device will automatically revert to write mode, ready to accept a new control word at SI.

*Table 4* shows an example of reading back the configuration registers of 4 devices in the first row of a 4x4 device array. Again, due to internal shift registers additional SCLK cycles will be necessary to complete the array read. It takes 4x30 SCLK clock cycles to shift out 4 30-bit configuration registers plus 7 SCLK cycles per device to account for device latency making for a total SCLK count of 148. The serialized read data is sampled at RSO and synchronized with RSCLK of the last device in the row. The user is recommended to backfill with all 0's at SI after the four reads have been shifted in.

**TABLE 3. Example to Program a 4 Device Array**

Frame D29:D24	Row Address D23:D18	Column Address D17:D12	OUT1 D11:D9	OUT2 D8:D6	OUT3 D5:D3	OUT4 D2:D0	Number of SCLK Cycles	Control Word Destination Device in Array Row, Column
01 1111	00 0000	00 0011	001	010	011	100	30	0, 3
01 1111	00 0000	00 0010	001	010	011	100	30	0, 2
01 1111	00 0000	00 0001	001	010	011	100	30	0, 1
01 1111	00 0000	00 0000	001	010	011	100	30	0, 0
Shift in configuration information from device furthest from system SI input first to minimize array latency during the programming process.								
The 2 clock cycle delay ensures all channel information has reached the "load" register and all switches are ready to be configured.							2	

**Functional Descriptions** (Continued)

**TABLE 4. A Read-Back Example from a 4 Device Array**

Frame D29:D24	Row Address D23:D18	Column Address D17:D12	OUT1 D11:D9	OUT2 D8:D6	OUT3 D5:D3	OUT4 D2:D0	Number of SCLK Cycles	Descriptions
01 1110	00 0000	11 1111	000	000	000	000	30	Read-Back (R,C)=0, 3
01 1110	00 0000	11 1110	000	000	000	000	30	Read-Back (R,C)=0, 2
01 1110	00 0000	11 1101	000	000	000	000	30	Read-Back (R,C)=0, 1
01 1110	00 0000	11 1100	001	010	011	100	30	Read-Back (R,C)=0, 0

**Note 7:** LOAD and READ programming example is based on the 16x16 array configuration shown in Figure 11. Alternative expansion array configurations will require a slightly different programming sequence.

**SWITCH EXPANSION FOR MINIMUM PROGRAMMING LATENCY**

Programming data ripples through the array through RSO and RSCLK in the row and CSO and CSCLK in the first column. LOAD pins of all devices are electrically tied to-

gether and driven by the same "load" signal. To prevent excessive stub length in the array from affecting the signal quality of LOAD, it is recommended that the load signal is distributed to each row or column in large crosspoint array applications.

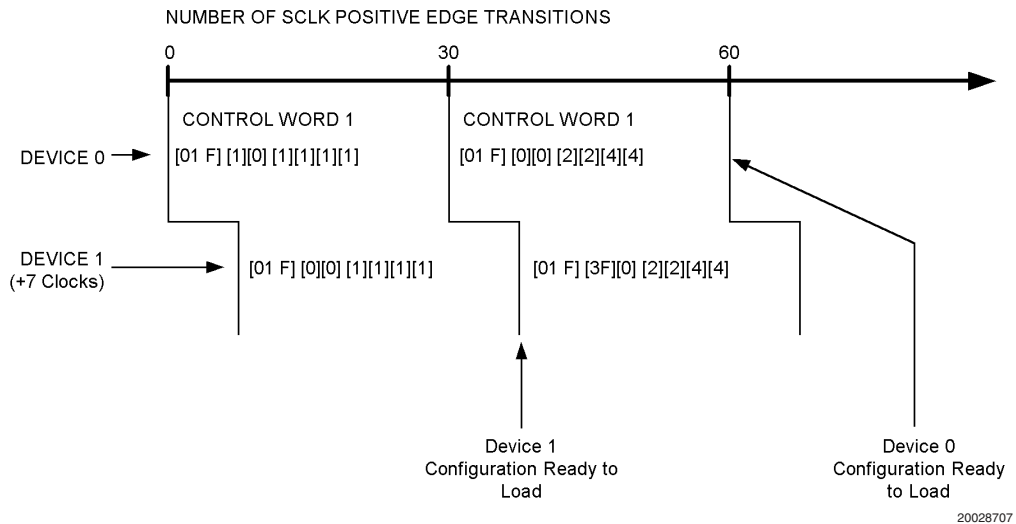

**FIGURE 11.**

## Programming Example

### CONFIGURATION WRITE

30 Bit Control Word: [WRITE FRAME] [ROW ADDRESS][COLUMN ADDRESS] [OUT1][OUT2][OUT3][OUT4]

### ARRAY WRITE:

[01 1111] [0][1] [1][1][1][1] /\*Array position 1, Broadcast IN1 \*/

[01 1111] [0][0] [2][2][4][4] /\*Array position 0, Connect IN2 to OUT1 and 2, IN4 to OUT3 and OUT4 \*/

LOAD = H and SCLK = LH

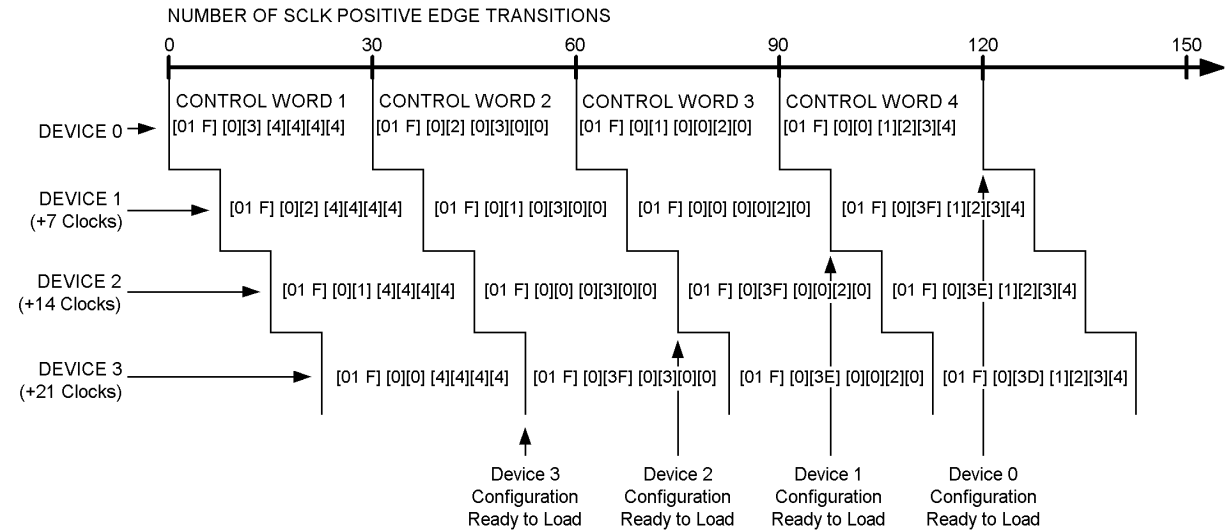

20028710

### DEVICE 0 WRITE PROGRAMMING SEQUENCE

SCLK Number	Event Description
6	Device 0 (R=0, C=0) detects "WRITE" frame of first Control Word.
18	Device 0 (R=0, C=0) sees Row = 1, Column = 0 of first Control Word. The Row address of the first Control Word is decremented by 1 (Row Address = 0) and sent out RSO.
36	Device 0 (R=0, C=0) detects "WRITE" frame of second Control Word.
48	Device 0 (R=0, C=0) sees Row = 0, Column = 0 of second Control Word. This is a valid configuration write address, Device 1 prepares to receive configuration information.
60	Device 0 (R=0, C=0) has received configuration information and is waiting for a LOAD.

### DEVICE 1 WRITE PROGRAMMING SEQUENCE

SCLK Number	Event Description
13	Device 1 (R=1, C=0) detects "WRITE" frame of first Control Word.
25	Device 1 (R=1,C=0) sees Row = 0, Column = 0 of first Control Word. This is a valid configuration write address, Device 1 prepares to receive configuration information.
37	Device 1 (R=1,C=0) has received configuration information and is waiting for a LOAD.
43	Device 1 (R=1, C=0) detects "WRITE" frame of second Control Word.
55	Device 1 (R=1,C=0) sees Row = 3F, Column = 0 of second Control Word. The Row address of the second Control Word is decremented by 1 (Row Address = 3E) and sent out RSO.

### CONFIGURATION READ

30 Bit Control Word: [READ FRAME] [ROW ADDRESS][COLUMN ADDRESS] [OUT1][OUT2][OUT3][OUT4]

### ARRAY WRITE:

[01 1110] [1][0] [0][0][0][0] /\*Array position 1, Return Configuration Information \*/

[01 1110] [0][0] [0][0][0][0] /\*Array position 0, Return Configuration Information \*/



### Programming Example (Continued)

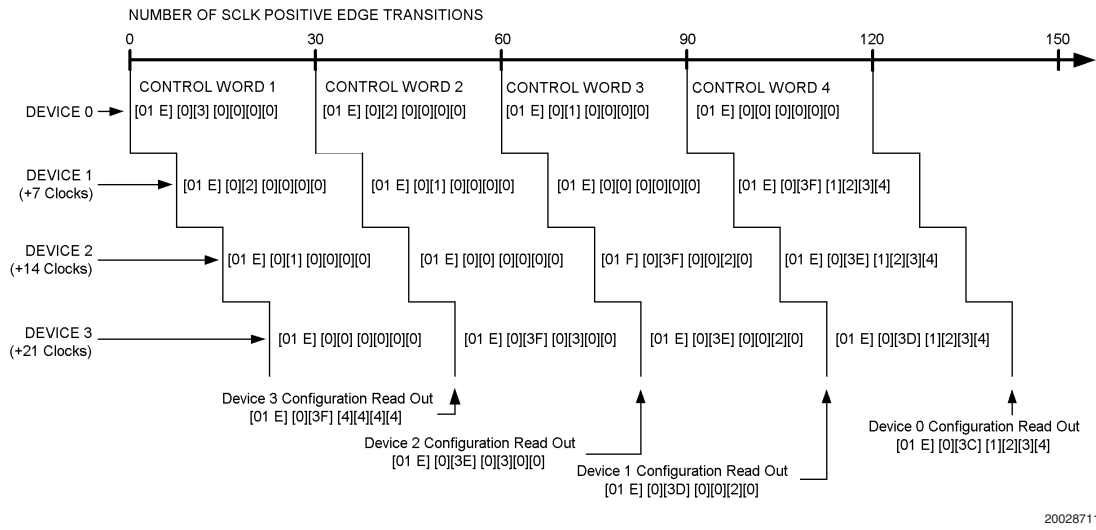

#### DEVICE 0 READ PROGRAMMING SEQUENCE

SCLK Number	Event Description
6	Device 0 (R=0, C=0) detects "READ" frame of first Control Word.
18	Device 0 (R=0,C=0) sees Row = 1, Column = 0 of first Control Word. The Row address of the first Control Word is decremented by 1 (Row Address = 0) and sent out RSO.
36	Device 0 (R=0,C=0) detects "READ" frame of second Control Word.
48	Device 0 (R=0,C=0) sees Row = 0, Column = 0 of second Control Word. This is a valid configuration read address, Device 0 prepares to transmit configuration information. The Row address of the last Control Word is decremented by 1 (Row Address = 3F) and sent out RSO.
60	Device 0 (R=0,C=0) has transmitted configuration information.
74	Finished transmitting configuration information at Array Output (RSO of Device 1).

#### DEVICE 1 READ PROGRAMMING SEQUENCE

SCLK Number	Event Description
13	Device 1 (R=1, C=0) detects "READ" frame of first Control Word.
25	Device 1 (R=1,C=0) sees Row = 0, Column = 0 of first Control Word. This is a valid configuration read address, Device 1 prepares to transmit configuration information. The Row address of the last Control Word is decremented by 1 (Row Address = 3F) and sent out RSO.
37	Device 1 (R=1,C=0) has transmitted configuration information at Array Output (RSO of Device 1).

**Physical Dimensions** inches (millimeters) unless otherwise noted

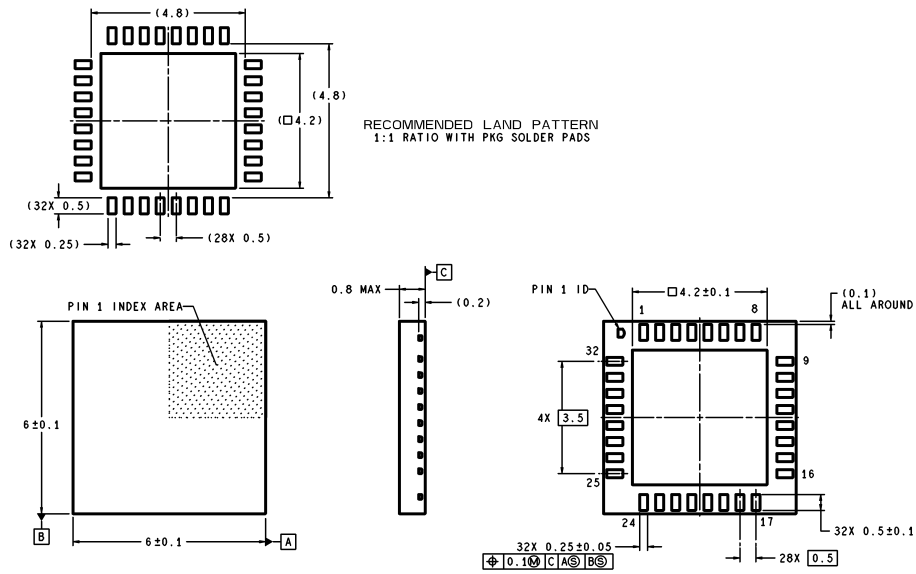

DIMENSIONS ARE IN MILLIMETERS

LQA32A (Rev. A)

**LLP, Plastic, QUAD,**  
**Order Number DS90CP04TLQ, DS90CP04TLQX (Tape and Reel)**  
**NS Package Number LQA032A**

**LIFE SUPPORT POLICY**

NATIONAL'S PRODUCTS ARE NOT AUTHORIZED FOR USE AS CRITICAL COMPONENTS IN LIFE SUPPORT DEVICES OR SYSTEMS WITHOUT THE EXPRESS WRITTEN APPROVAL OF THE PRESIDENT AND GENERAL COUNSEL OF NATIONAL SEMICONDUCTOR CORPORATION. As used herein:

1. Life support devices or systems are devices or systems which, (a) are intended for surgical implant into the body, or (b) support or sustain life, and whose failure to perform when properly used in accordance with instructions for use provided in the labeling, can be reasonably expected to result in a significant injury to the user.
2. A critical component is any component of a life support device or system whose failure to perform can be reasonably expected to cause the failure of the life support device or system, or to affect its safety or effectiveness.

 **National Semiconductor**  
**Americas Customer**  
**Support Center**  
 Email: new.feedback@nsc.com  
 Tel: 1-800-272-9959  
 www.national.com

**National Semiconductor**  
**Europe Customer Support Center**  
 Fax: +49 (0) 180-530 85 86  
 Email: europe.support@nsc.com  
 Deutsch Tel: +49 (0) 69 9508 6208  
 English Tel: +44 (0) 870 24 0 2171  
 Français Tel: +33 (0) 1 41 91 8790

**National Semiconductor**  
**Asia Pacific Customer**  
**Support Center**  
 Email: ap.support@nsc.com

**National Semiconductor**  
**Japan Customer Support Center**  
 Fax: 81-3-5639-7507  
 Email: jpn.feedback@nsc.com  
 Tel: 81-3-5639-7560