

# ADC0841

## 8-Bit $\mu$ P Compatible A/D Converter

### General Description

The ADC0841 is a CMOS 8-bit successive approximation A/D converter. Differential inputs provide low frequency input common mode rejection and allow offsetting the analog range of the converter. In addition, the reference input can be adjusted enabling the conversion of reduced analog ranges with 8-bit resolution.

The A/D is designed to operate with the control bus of a variety of microprocessors. TRI-STATE<sup>®</sup> output latches that directly drive the data bus permit the A/D to be configured as a memory location or I/O device to the microprocessor with no interface logic necessary.

### Features

- Easy interface to all microprocessors

- Operates ratiometrically or with 5  $V_{DC}$  voltage reference
- No zero or full-scale adjust required
- Internal clock
- 0V to 5V input range with single 5V power supply
- 0.3" standard width 20-pin package
- 20 Pin Molded Chip Carrier Package

### Key Specifications

- Resolution: 8 Bits
- Total Unadjusted Error:  $\pm 1/2$  LSB and  $\pm 1$  LSB
- Single Supply: 5  $V_{DC}$
- Low Power: 15 mW
- Conversion Time: 40  $\mu$ s

### Block and Connection Diagrams

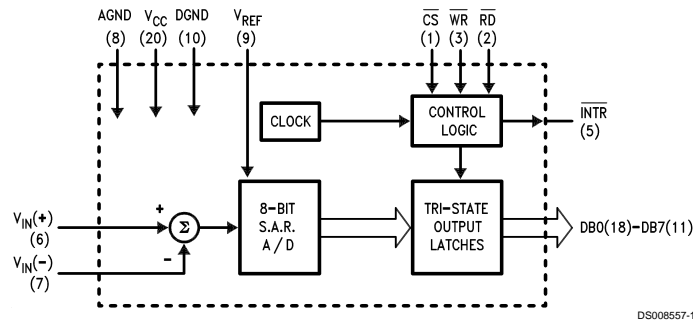

DS008557-1

Dual-In-Line Package (N)

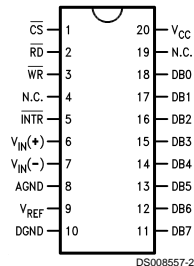

DS008557-2

(N.C.-No Connection)

Top View

Molded Chip Carrier Package (V)

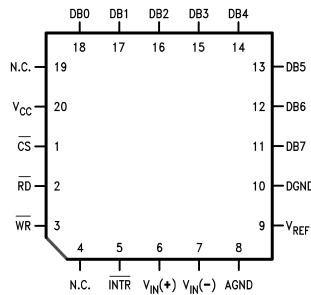

DS008557-3

Top View

TRI-STATE<sup>®</sup> is a registered trademark of National Semiconductor Corporation.  
NSC800<sup>™</sup> is a trademark of National Semiconductor Corporation.

## Absolute Maximum Ratings (Notes 1, 2)

If Military/Aerospace specified devices are required, please contact the National Semiconductor Sales Office/Distributors for availability and specifications.

Supply Voltage ( $V_{CC}$ )	6.5V
Voltage	
Logic Control Inputs	-0.3V to $V_{CC}+0.3V$
At Other Inputs and Outputs	-0.3V to $V_{CC}+0.3V$
Input Current Per Pin (Note 3)	$\pm 5$ mA
Input Current Per Package (Note 3)	$\pm 20$ mA
Storage Temperature	-65°C to +150°C
Package Dissipation at $T_A=25^\circ\text{C}$	875 mW

Lead Temp. (Soldering, 10 seconds)	
Dual-In-Line Package (Plastic)	
Molded Chip Carrier Package	260°C
Vapor Phase (60 seconds)	215°C
Infrared (15 seconds)	220°C
ESD Susceptibility (Note 10)	800V

## Operating Conditions (Notes 1, 2)

Supply Voltage ( $V_{CC}$ )	4.5 $V_{DC}$ to 6.0 $V_{DC}$
Temperature Range	$T_{MIN} \leq T_A \leq T_{MAX}$
ADC0841BCN, ADC0841CCN	$0^\circ\text{C} \leq T_A \leq 70^\circ\text{C}$
ADC0841BCV, ADC0841CCV	$-40^\circ\text{C} \leq T_A \leq 85^\circ\text{C}$

## Electrical Characteristics

The following specifications apply for  $V_{CC}=5 V_{DC}$  unless otherwise specified. **Boldface limits apply from  $T_{MIN}$  to  $T_{MAX}$** ; all other limits  $T_A=T_J=25^\circ\text{C}$ .

Parameter	Conditions	ADC0841BCN, ADC0841CCN ADC0841BCV, ADC0841CCV			Units
		Typ (Note 6)	Tested Limit (Note 7)	Design Limit (Note 8)	
<b>CONVERTER AND MULTIPLEXER CHARACTERISTICS</b>					
Maximum Total Unadjusted Error	$V_{REF}=5.00 V_{DC}$ (Note 4)				
ADC0841BCN, BCV			$\pm 1/2$	$\pm 1/2$	LSB
ADC0841CCN, CCV			$\pm 1$	<b><math>\pm 1</math></b>	LSB
Minimum Reference Input Resistance		2.4	1.2	<b>1.1</b>	k $\Omega$
Maximum Reference Input Resistance		2.4	5.4	<b>5.9</b>	k $\Omega$
Maximum Common-Mode Input Voltage	(Note 5)		$V_{CC}+0.05$	<b><math>V_{CC}+0.05</math></b>	V
Minimum Common-Mode Input Voltage	(Note 5)		$GND-0.05$	<b><math>GND-0.05</math></b>	V
DC Common-Mode Error	Differential Mode	$\pm 1/16$	$\pm 1/4$	$\pm 1/4$	LSB
Power Supply Sensitivity	$V_{CC}=5V \pm 5\%$	$\pm 1/16$	$\pm 1/8$	$\pm 1/8$	LSB

## Electrical Characteristics

The following specifications apply for  $V_{CC}=5 V_{DC}$  unless otherwise specified. **Boldface limits apply from  $T_{MIN}$  to  $T_{MAX}$** ; all other limits  $T_A=T_J=25^\circ\text{C}$ .

Symbol	Parameter	Conditions	ADC0841BCN, ADC0841CCN ADC0841BCV, ADC0841CCV			Units
			Typ (Note 6)	Tested Limit (Note 7)	Design Limit (Note 8)	
<b>DIGITAL AND DC CHARACTERISTICS</b>						
$V_{IN(1)}$	Logical "1" Input Voltage (Min)	$V_{CC}=5.25V$		2.0	<b>2.0</b>	V
$V_{IN(0)}$	Logical "0" Input Voltage (Max)	$V_{CC}=4.75V$		0.8	<b>0.8</b>	V
$I_{IN(1)}$	Logical "1" Input Current (Max)	$V_{IN}=5.0V$	0.005		<b>1</b>	$\mu\text{A}$

## Electrical Characteristics (Continued)

The following specifications apply for  $V_{CC}=5V_{DC}$  unless otherwise specified. **Boldface limits apply from  $T_{MIN}$  to  $T_{MAX}$** ; all other limits  $T_A=T_J=25^{\circ}C$ .

Symbol	Parameter	Conditions	ADC0841BCN, ADC0841CCN ADC0841BCV, ADC0841CCV			Units
			Typ (Note 6)	Tested Limit (Note 7)	Design Limit (Note 8)	
<b>DIGITAL AND DC CHARACTERISTICS</b>						
$I_{IN(0)}$	Logical "0" Input Current (Max)	$V_{IN}=0V$	-0.005		<b>-1</b>	$\mu A$
$V_{OUT(1)}$	Logical "1" Output Voltage (Min)	$V_{CC}=4.75V$		2.8	<b>2.4</b>	V
		$I_{OUT}=-360\mu A$ $I_{OUT}=-10\mu A$		4.6	<b>4.5</b>	V
$V_{OUT(0)}$	Logical "0" Output Voltage (Max)	$V_{CC}=4.75V$ $I_{OUT}=1.6mA$		0.34	<b>0.4</b>	V
$I_{OUT}$	TRI-STATE Output Current (Max)	$V_{OUT}=0V$	-0.01	-0.3	<b>-3</b>	$\mu A$
		$V_{OUT}=5V$	0.01	0.3	<b>3</b>	$\mu A$
$I_{SOURCE}$	Output Source Current (Min)	$V_{OUT}=0V$	-14	-7.5	<b>-6.5</b>	mA
$I_{SINK}$	Output Sink Current (Min)	$V_{OUT}=V_{CC}$	16	9.0	<b>8.0</b>	mA
$I_{CC}$	Supply Current (Max)	$\overline{CS}=1, V_{REF}$ Open	1	2.3	<b>2.5</b>	mA

## AC Characteristics

The following specifications apply for  $V_{CC}=5V_{DC}$ ,  $t_r=t_f=10ns$  unless otherwise specified. **Boldface limits apply from  $T_{MIN}$  to  $T_{MAX}$** ; all other limits  $T_A=T_J=25^{\circ}C$ .

Symbol	Parameter	Conditions	Typ (Note 6)	Tested Limit (Note 7)	Design Limit (Note 8)	Units
$t_C$	Maximum Conversion Time (See Graph)		30	40	<b>60</b>	$\mu s$
$t_{W(\overline{WR})}$	Minimum $\overline{WR}$ Pulse Width	(Note 9)	50	150		ns
$t_{ACC}$	Maximum Access Time (Delay from Falling Edge of $\overline{RD}$ to Output Data Valid)	$C_L=100pF$ (Note 9)	145	225		ns
$t_{1H}, t_{0H}$	TRI-STATE Control (Maximum Delay from Rising Edge of $\overline{RD}$ to Hi-Z State)	$C_L=10pF, R_L=10k,$ $t_r=20ns$ (Note 9)	125		200	ns
$t_{WI}, t_{RI}$	Maximum Delay from Falling Edge of $\overline{WR}$ or $\overline{RD}$ to Reset of $INTR$	(Note 9)	200	400		ns
$C_{IN}$	Capacitance of Logic Inputs		5			pF
$C_{OUT}$	Capacitance of Logic Outputs		5			pF

**Note 1:** Absolute Maximum Ratings indicate limits beyond which damage to the device may occur. DC and AC electrical specifications do not apply when operating the device beyond its specified operating conditions.

**Note 2:** All voltages are measured with respect to the ground pins.

**Note 3:** During over-voltage conditions ( $V_{IN}<0V$  and  $V_{IN}>V_{CC}$ ) the maximum input current at any one pin is  $\pm 5mA$ . If the current is limited to  $\pm 5mA$  at all the pins no more than four pins can be in this condition in order to meet the Input Current Per Package ( $\pm 20mA$ ) specification.

**Note 4:** Total unadjusted error includes offset, full-scale, and linearity.

**Note 5:** For  $V_{IN}(-) \geq V_{IN}(+)$  the digital output code will be 0000 0000. Two on-chip diodes are tied to each analog input, which will forward-conduct for analog input voltages one diode drop below ground or one diode drop greater than  $V_{CC}$  supply. Be careful during testing at low  $V_{CC}$  levels (4.5V), as high level analog inputs (5V) can cause this input diode to conduct, especially at elevated temperatures, and cause errors for analog inputs near full-scale. The spec allows 50 mV forward bias of either diode. This means that as long as the analog  $V_{IN}$  does not exceed the supply voltage by more than 50 mV, the output code will be correct. To achieve an absolute 0  $V_{DC}$  to 5  $V_{DC}$  input voltage range will therefore require a minimum supply voltage of 4.950  $V_{DC}$  over temperature variations, initial tolerance and loading.

**Note 6:** Typical values are at 25°C and represent most likely parametric norm.

**Note 7:** Tested limits are guaranteed to National's AOQL (Average Outgoing Quality Level).

**Note 8:** Design limits are guaranteed but not 100% production tested. These limits are not used to calculate outgoing quality levels.

**Note 9:** The temperature coefficient is 0.3%/°C.

**Note 10:** Human body model, 100 pF discharged through 1.5 k $\Omega$  resistor.

## Timing Diagram

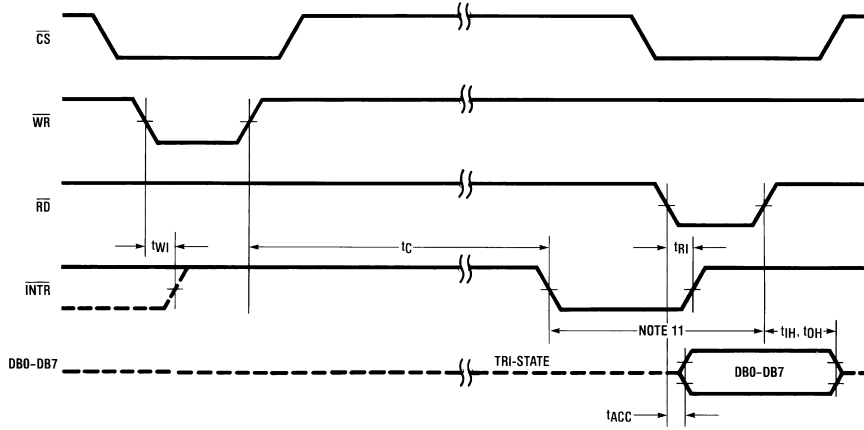

DS008557-9

Note 11: Read strobe must occur at least 600 ns after the assertion of interrupt to guarantee reset of  $\overline{INTR}$ .

## Typical Performance Characteristics

Logic Input Threshold Voltage vs Supply Voltage

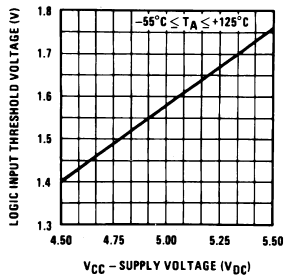

DS008557-23

Output Current vs Temperature

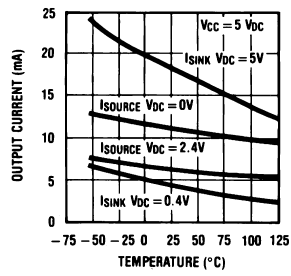

DS008557-24

Power Supply Current vs Temperature

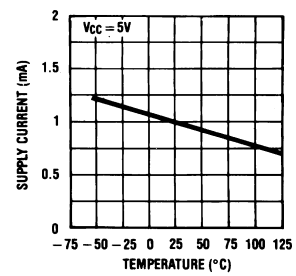

DS008557-25

Linearity Error vs  $V_{REF}$

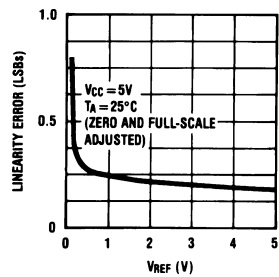

DS008557-26

Conversion Time vs  $V_{SUPPLY}$

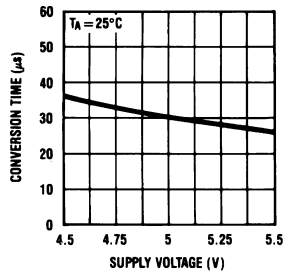

DS008557-27

Conversion Time vs Temperature

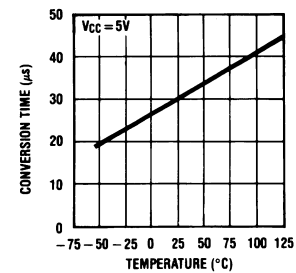

DS008557-28

## Typical Performance Characteristics (Continued)

### Unadjusted Offset Error vs $V_{REF}$ Voltage

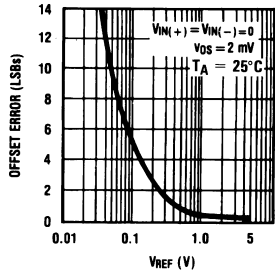

DS008557-22

### TRI-STATE Test Circuits and Waveforms

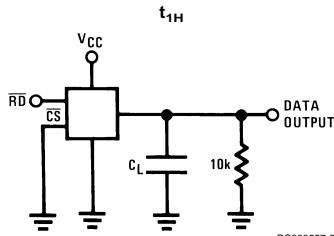

DS008557-5

$t_r = 20$  ns

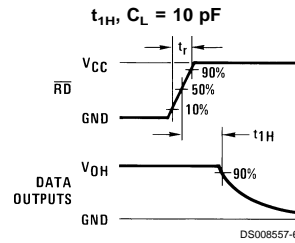

DS008557-6

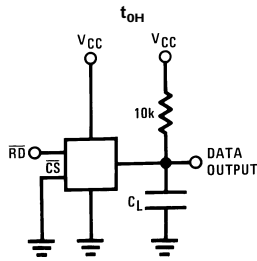

DS008557-7

$t_r = 20$  ns

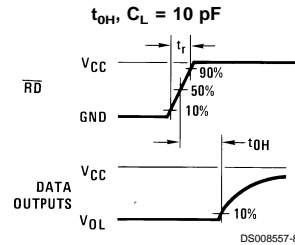

DS008557-8

# Functional Block Diagram

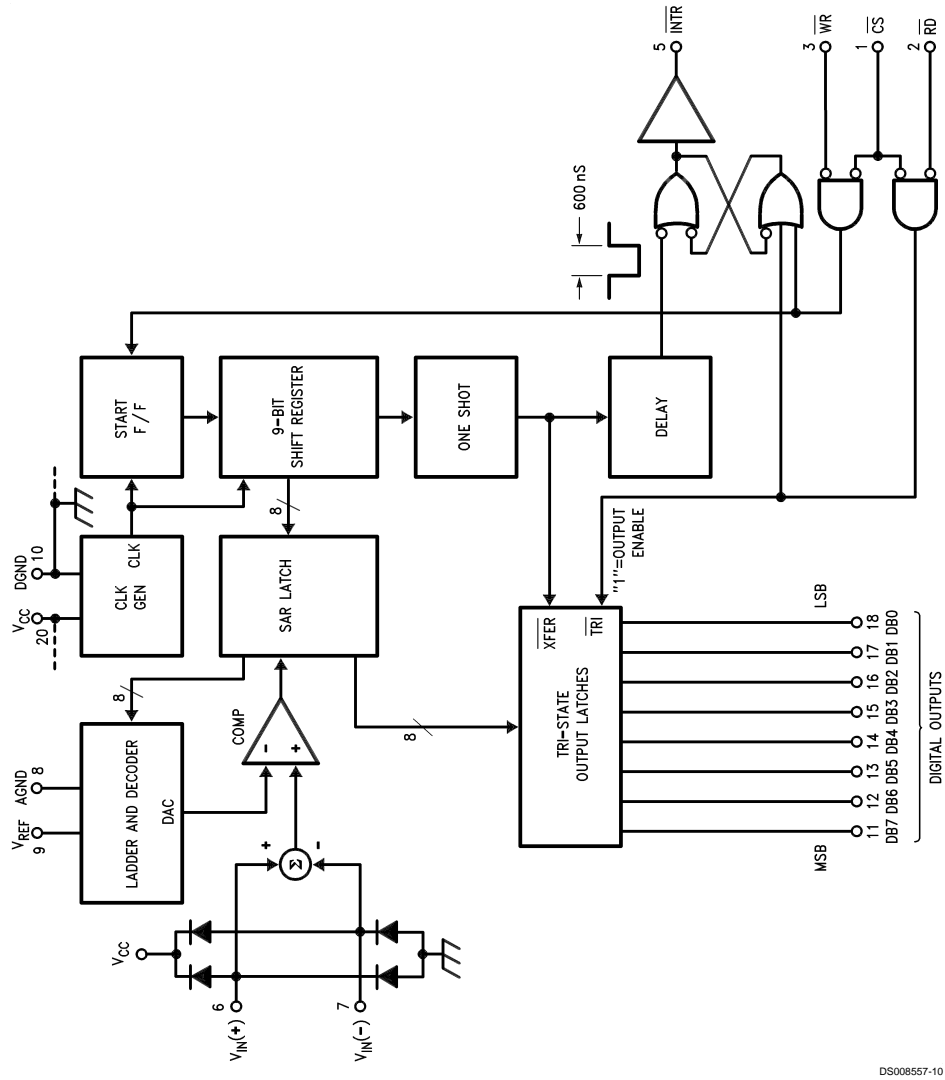

DS008557-10

## Functional Description

A conversion is initiated via the  $\overline{CS}$  and  $\overline{WR}$  lines. If the data from a previous conversion is not read, the  $\overline{INTR}$  line will be low. The falling edge of  $\overline{WR}$  will reset the  $\overline{INTR}$  line high and ready the A/D for a conversion cycle. The rising edge of  $\overline{WR}$  starts a conversion. After the conversion cycle ( $t_C \leq 60 \mu\text{sec}$ ), which is set by the internal clock frequency, the digital data is transferred to the output latch and the  $\overline{INTR}$  is asserted low. Taking  $\overline{CS}$  and  $\overline{RD}$  low resets  $\overline{INTR}$  output high and transfers the conversion result on the output data lines (DB0–DB7).

## Applications Information

### 1.0 REFERENCE CONSIDERATIONS

The voltage applied to the reference input of this converter defines the voltage span of the analog input (the difference between  $V_{IN(MAX)}$  and  $V_{IN(MIN)}$ ) over which the 256 possible output codes apply. The device can be used in either ratiometric applications or in systems requiring absolute accuracy. The reference pin must be connected to a voltage source capable of driving the minimum reference input resistance of  $1.1 \text{ k}\Omega$ . This pin is the top of a resistor divider string used for the successive approximation conversion.

In a ratiometric system (*Figure 1a*), the analog input voltage is proportional to the voltage used for the A/D reference. This voltage is typically the system power supply, so the  $V_{REF}$  pin can be tied to  $V_{CC}$ . This technique relaxes the stability requirements of the system reference as the analog input and A/D reference move together maintaining the same output code for a given input condition.

For absolute accuracy (*Figure 1b*), where the analog input varies between very specific voltage limits, the reference pin can be biased with a time and temperature stable voltage source. The LM385 and LM336 reference diodes are good low current devices to use with this converter.

The maximum value of the reference is limited to the  $V_{CC}$  supply voltage. The minimum value, however, can be quite small (see Typical Performance Characteristics) to allow direct conversions of transducer outputs providing less than a 5V output span. Particular care must be taken with regard to noise pickup, circuit layout and system error voltage sources when operating with a reduced span due to the increased sensitivity of the converter (1 LSB equals  $V_{REF}/256$ ).

### 2.0 THE ANALOG INPUTS

#### 2.1 Analog Differential Voltage Inputs and Common-Mode Rejection

The differential inputs of this converter actually reduce the effects of common-mode input noise, a signal common to both selected "+" and "-" inputs for a conversion (60 Hz is most typical). The time interval between sampling the "+" input and then the "-" input is  $\frac{1}{2}$  of a clock period. The change in the common-mode voltage during this short time interval can cause conversion errors. For a sinusoidal common-mode signal this error is:

$$V_{ERROR(MAX)} = V_{peak} (2\pi f_{CM}) \times 0.5 \times \left(\frac{t_C}{8}\right)$$

where  $f_{CM}$  is the frequency of the common-mode signal,  $V_{peak}$  is its peak voltage value and  $t_C$  is the conversion time.

For a 60 Hz common-mode signal to generate a  $\frac{1}{4}$  LSB error ( $\approx 5 \text{ mV}$ ) with the converter running at  $40 \mu\text{s}$ , its peak value would have to be 5.43V. This large common-mode signal is much greater than that generally found in a well designed data acquisition system.

#### 2.2 Input Current

Due to the sampling nature of the analog inputs, short duration spikes of current enter the "+" input and exit the "-" input at the clock edges during the actual conversion. These currents decay rapidly and do not cause errors as the internal comparator is strobed at the end of a clock period. Bypass capacitors at the inputs will average these currents and cause an effective DC current to flow through the output resistance of the analog signal source. Bypass capacitors should not be used if the source resistance is greater than  $1 \text{ k}\Omega$ . An op amp RC active low pass filter can provide both impedance buffering and noise filtering should a high impedance signal source be required.

### 3.0 OPTIONAL ADJUSTMENTS

#### 3.1 Zero Error

The zero of the A/D does not require adjustment. If the minimum analog input voltage value,  $V_{IN(MIN)}$ , is not ground, a zero offset can be done. The converter can be made to output 0000 0000 digital code for this minimum input voltage by biasing the  $V_{IN}(-)$  input at this  $V_{IN(MIN)}$  value.

The zero error of the A/D converter relates to the location of the first riser of the transfer function and can be measured by grounding the  $V^-$  input and applying a small magnitude positive voltage to the  $V^+$  input. Zero error is the difference between actual DC input voltage which is necessary to just cause an output digital code transition from 0000 0000 to 0000 0001 and the ideal  $\frac{1}{2}$  LSB value ( $\frac{1}{2} \text{ LSB} = 9.8 \text{ mV}$  for  $V_{REF} = 5.000 \text{ V}_{DC}$ ).

#### 3.2 Full-Scale

The full-scale adjustment can be made by applying a differential input voltage which is  $1 \frac{1}{2}$  LSB down from the desired analog full-scale voltage range and then adjusting the magnitude of the  $V_{REF}$  input for a digital output code changing from 1111 1110 to 1111 1111.

#### 3.3 Adjusting for an Arbitrary Analog Input Voltage Range

If the analog zero voltage of the A/D is shifted away from ground (for example, to accommodate an analog input signal which does not go to ground), this new zero reference should be properly adjusted first. A voltage which equals this desired zero reference plus  $\frac{1}{2}$  LSB (where the LSB is calculated for the desired analog span,  $1 \text{ LSB} = \text{analog span}/256$ ) is applied to the "+" input ( $V_{IN}^{(+)}$ ) and the zero reference voltage at the "-" input ( $V_{IN}^{(-)}$ ) should then be adjusted to just obtain the  $00_{HEX}$  to  $01_{HEX}$  code transition.

## Applications Information (Continued)

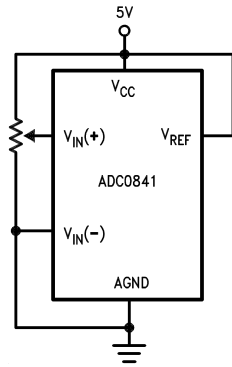

DS008557-11

a) Ratiometric

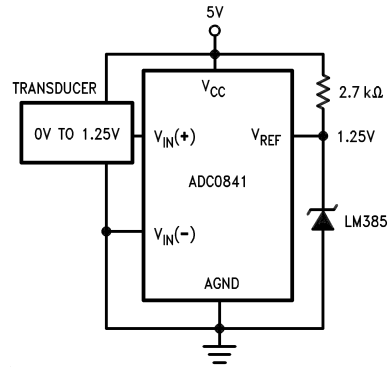

DS008557-12

b) Absolute with a Reduced Span

FIGURE 1. Referencing Examples

The full-scale adjustment should be made [with the proper  $V_{IN(-)}$  voltage applied] by forcing a voltage to the  $V_{IN(+)}$  input which is given by:

$$V_{IN(+)} \text{ fs adj} = V_{MAX} - 1.5 \left[ \frac{(V_{MAX} - V_{MIN})}{256} \right]$$

where  $V_{MAX}$  = the high end of the analog input range and  $V_{MIN}$  = the low end (the offset zero) of the analog range. (Both are ground referenced.)

The  $V_{REF}$  (or  $V_{CC}$ ) voltage is then adjusted to provide a code change from  $FE_{HEX}$  to  $FF_{HEX}$ . This completes the adjustment procedure.

For an example see the Zero-Shift and Span Adjust circuit below.

### Zero Shift and Span Adjust ( $2V \leq V_{IN} \leq 5V$ )

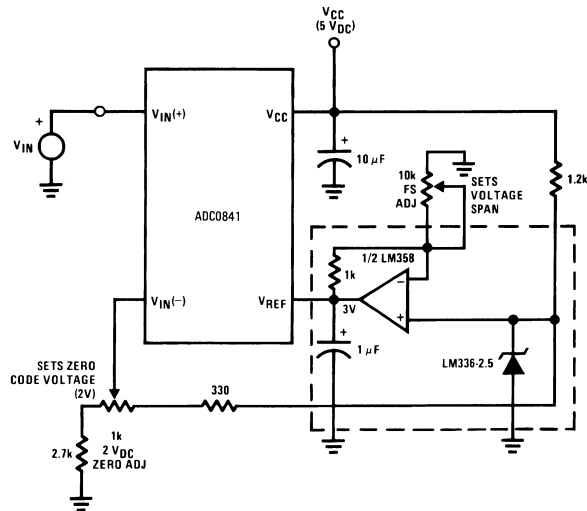

DS008557-13



## Applications Information (Continued)

### Span Adjust $0V \leq V_{IN} \leq 3V$

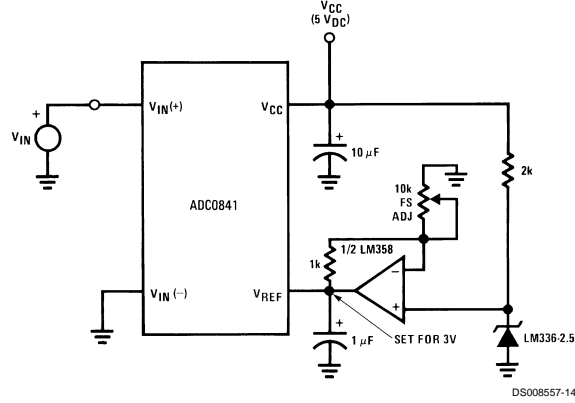

### Protecting the Input

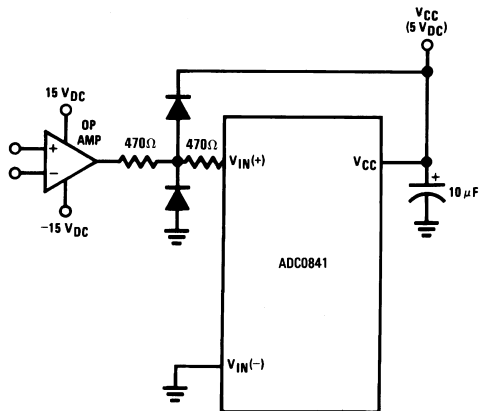

Diodes are 1N914

### High Accuracy Comparator

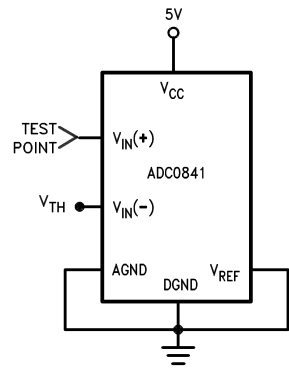

DO=all 1s if  $V_{IN(+)} > V_{IN(-)}$   
DO=all 0s if  $V_{IN(+)} < V_{IN(-)}$

## Applications Information (Continued)

### Continuous Conversion

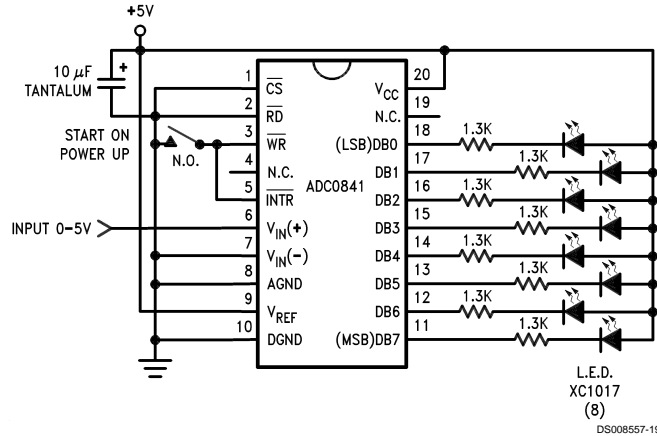

### Operating with Automotive Ratimetric Transducers

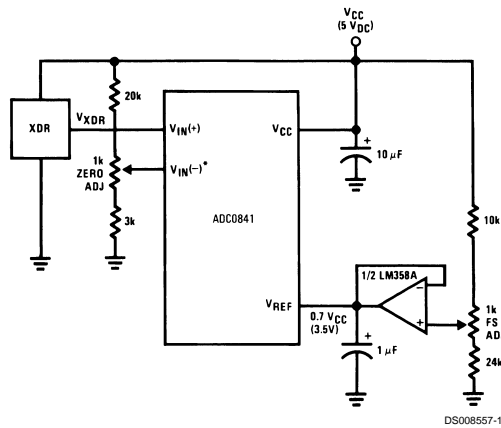

\* $V_{IN(-)} = 0.15 V_{CC}$   
 $15\% \text{ of } V_{CC} \leq V_{XDR} \leq 85\% \text{ of } V_{CC}$

### SAMPLE PROGRAM FOR ADC0841 — INS8039 INTERFACE CONVERTING TWO RATIOMETRIC, DIFFERENTIAL SIGNALS

```

                                ORG      0H
                                JMP      BEGIN          ;START PROGRAM AT ADDR 10
                                ORG      10H           ;MAIN PROGRAM
0010      B9 FF      BEGIN:     MOV      R1,#0FFH      ;LOAD R1 WITH A UNUSED ADDR
                                                ;LOCATION
0012      B8 20           MOV      R0,#20H          ;A/D DATA ADDRESS
0014      89 FF           ORL      P1,#0FFH         ;SET PORT 1 OUTPUTS HIGH
0016      23 00           MOV      A,00H          ;LOAD THE ACC WITH 00
0018      14 50           CALL     CONV          ;CALL THE CONVERSION SUBROUTINE

                                ;CONTINUE MAIN PROGRAM
  
```

## Applications Information (Continued)

```

;CONVERSION SUBROUTINE
;ENTRY: ACC—A/D MUX DATA
;EXIT: ACC—CONVERTED DATA

```

```

                                ORG      50H
0050    99 FE      CONV:    ANL      P1,#0FEH      ;CHIP SELECT THE A/D
0052    91          MOVX    @R1,A                ;START CONVERSION
0053    09          LOOP:   IN       A,P1         ;INPUT  $\overline{\text{INTR}}$  STATE
0054    32 53      JB1     LOOP                ;IF  $\overline{\text{INTR}} = 1$  GOTO LOOP
0056    81          MOVX    A,@R1              ;IF  $\overline{\text{INTR}} = 0$  INPUT A/D DATA
0057    89 01      ORL     P1,&01H             ;CLEAR THE A/D CHIP SELECT
0059    A0          MOV     @R0,A             ;STORE THE A/D DATA
005A    83          RET     ;RETURN TO MAIN PROGRAM

```

ADC0841\_INS8039 Interface

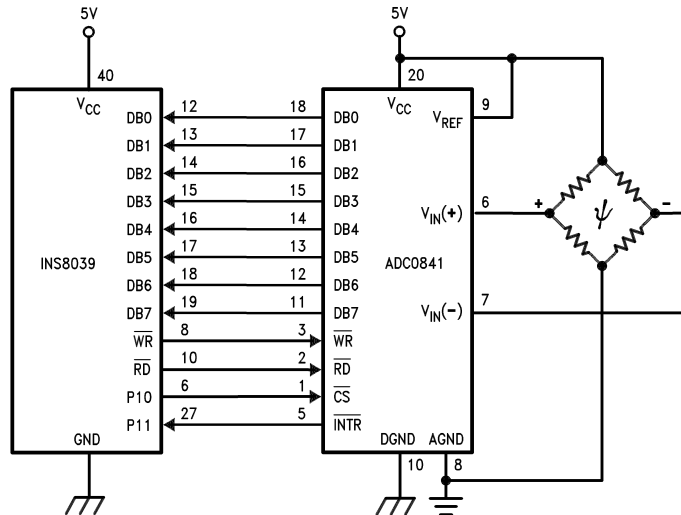

DS008557-20

## Applications Information (Continued)

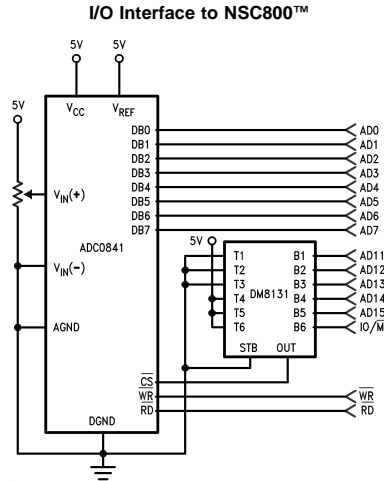

### SAMPLE PROGRAM FOR ADC0841 — NSC800 INTERFACE

```

0010          NCONV      EQU      16          ;TWICE THE NUMBER OF REQUIRED
                                          ;CONVERSIONS
000F          DEL        EQU      15          ;DELAY 60 µsec CONVERSION
001F          CS         EQU      1FH         ;THE BOARD ADDRESS
3C00          ADDTA      EQU      003CH       ;START OF RAM FOR A/D
                                          ;DATA
0000'        00         DTA:         DB      08H          ;DATA
0001'        0E 1F      START:      LD      C,CS
0003'        06 16          LD      B,NCONV
0005'        21 0000'    LD      HL,DTA
0008'        11 003C    LD      DE,ADDTA
000B'        ED A3      STCONV:     OUTI          ;START A CONVERSION
000D'        EB          EX      DE,HL        ;HL=RAM ADDRESS FOR THE
                                          ;A/D DATA
000E'        3E 0F          LD      A,DEL
0010'        3D          WAIT:      DEC     A          ;WAIT 60 µsec FOR THE
0011'        C2 0013'    JP      NZ,WAIT      ;CONVERSION TO FINISH
0014'        ED A2          INI          ;STORE THE A/D'S DATA
                                          ;THE REQUIRED CONVERSIONS
                                          ;COMPLETED?
0016'        EB          EX      DE,HL
0017'        C2 000E'    JP      NZ,STCONV    ;IF NOT GOTO STCONV

          END

```

**Note 12:** A conversion is started, then a 60 µs wait for the A/D to complete a conversion and the data is stored at address ADDTA for the first conversion, ADDTA + 1 for the second conversion, etc. for a total of 8 conversions.

## Ordering Information

Temperature Range	Total Unadjusted Error		Package Outline
	$\pm 1/2$ LSB	$\pm 1$ LSB	
0°C to +70°C	ADC0841BCN	ADC0841CCN	N20A Molded Dip
-40°C to +85°C	ADC0841BCV	ADC0841CCV	V20A Molded Chip Carrier

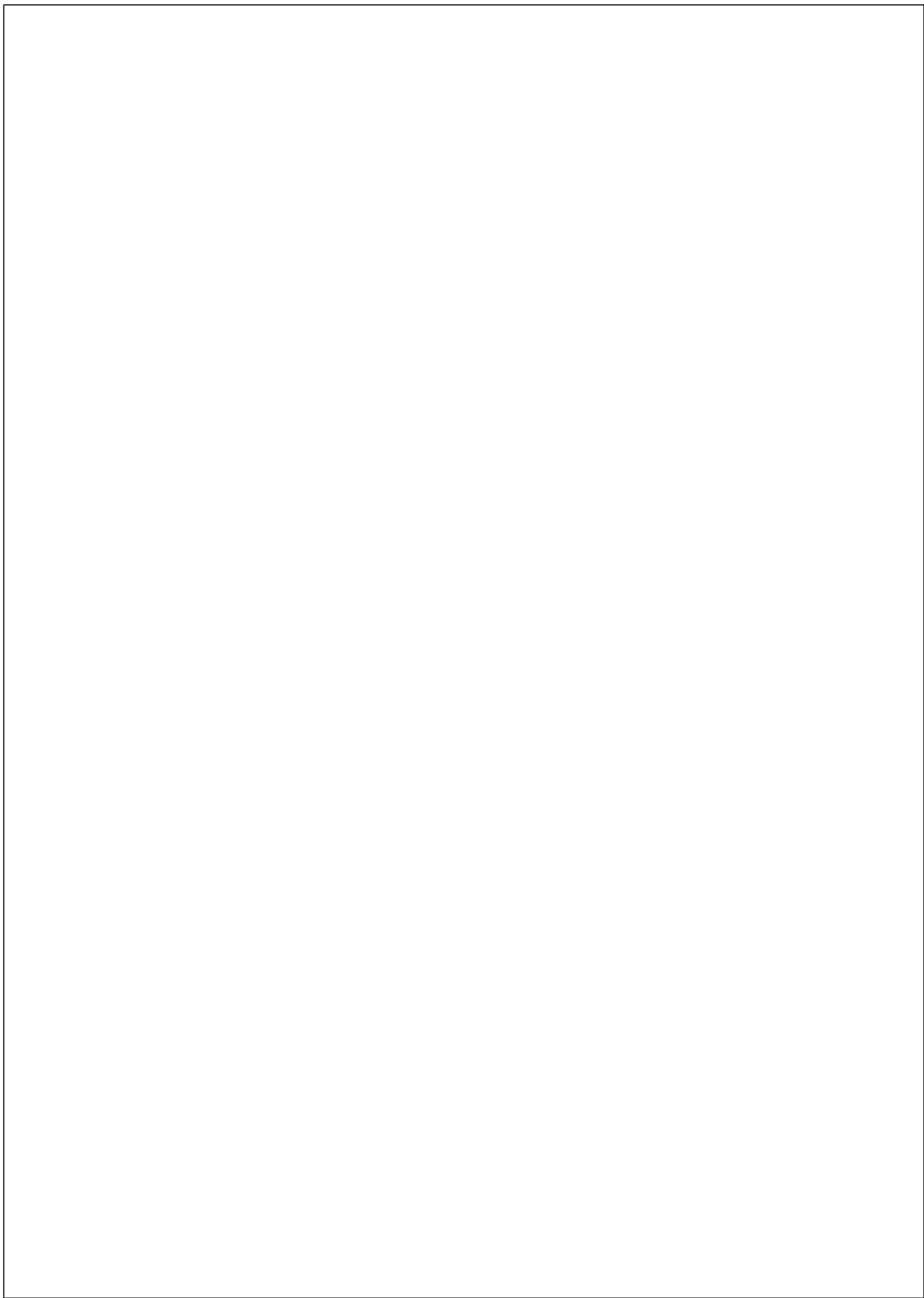

**Physical Dimensions** inches (millimeters) unless otherwise noted

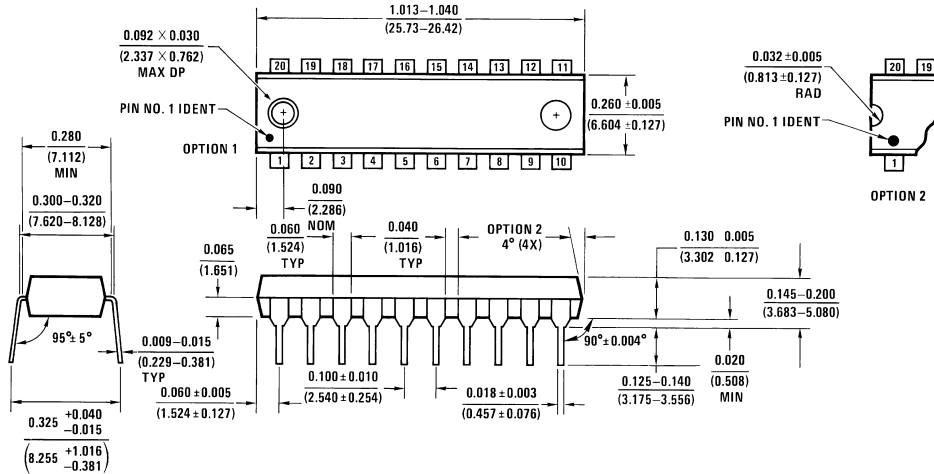

N20A (REV G)

**Molded Dual-In-Line Package (N)**  
Order Number ADC0841BCN or ADC0841CCN  
NS Package Number N20A

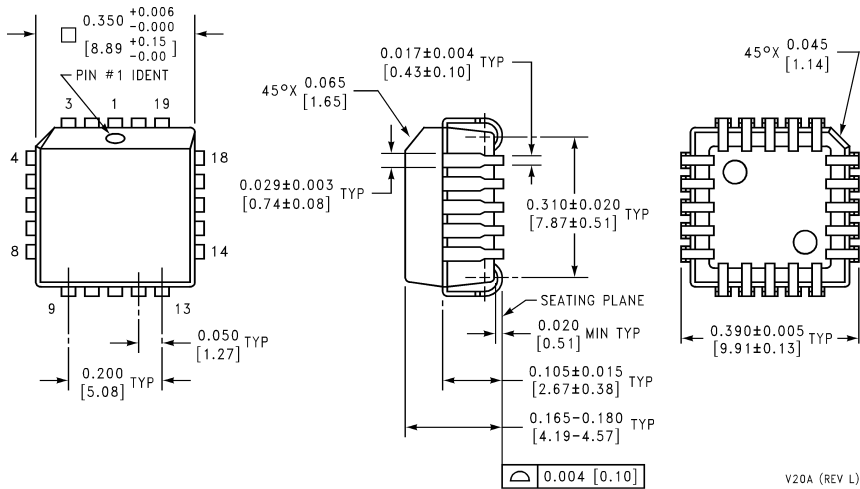

V20A (REV L)

**Molded Chip Carrier Package (V)**  
Order Number ADC0841BCV or ADC0841CCV  
NS Package Number V20A

#### LIFE SUPPORT POLICY

NATIONAL'S PRODUCTS ARE NOT AUTHORIZED FOR USE AS CRITICAL COMPONENTS IN LIFE SUPPORT DEVICES OR SYSTEMS WITHOUT THE EXPRESS WRITTEN APPROVAL OF THE PRESIDENT OF NATIONAL SEMICONDUCTOR CORPORATION. As used herein:

1. Life support devices or systems are devices or systems which, (a) are intended for surgical implant into the body, or (b) support or sustain life, and whose failure to perform when properly used in accordance with instructions for use provided in the labeling, can be reasonably expected to result in a significant injury to the user.
2. A critical component is any component of a life support device or system whose failure to perform can be reasonably expected to cause the failure of the life support device or system, or to affect its safety or effectiveness.



**National Semiconductor Corporation**  
Americas  
Tel: 1-800-272-9959  
Fax: 1-800-737-7018  
Email: support@nsc.com

[www.national.com](http://www.national.com)

**National Semiconductor Europe**  
Fax: +49 (0) 1 80-530 85 86  
Email: europe.support@nsc.com  
Deutsch Tel: +49 (0) 1 80-530 85 85  
English Tel: +49 (0) 1 80-532 78 32  
Français Tel: +49 (0) 1 80-532 93 58  
Italiano Tel: +49 (0) 1 80-534 16 80

**National Semiconductor Asia Pacific Customer Response Group**  
Tel: 65-2544466  
Fax: 65-2504466  
Email: sea.support@nsc.com

**National Semiconductor Japan Ltd.**  
Tel: 81-3-5639-7560  
Fax: 81-3-5639-7507