

DS78C120 Dual CMOS Compatible Differential Line Receiver

General Description

The DS78C120 is a high performance, dual differential, CMOS compatible line receiver for both balanced and unbalanced digital data transmission. The inputs are compatible with EIA, Federal and MIL standards.

Input specifications meet or exceed those of the popular DS7820 line receiver.

The line receiver will discriminate a ± 200 mV input signal over a common-mode range of ± 10 V and a ± 300 mV signal over a range of ± 15 V.

Circuit features include hysteresis and response control for applications where controlled rise and fall times and/or high frequency noise rejection are desirable. Threshold offset control is provided for fail-safe detection, should the input be open or short. Each receiver includes a 180Ω terminating resistor and the output gate contains a logic strobe for time discrimination. The DS78C120 is specified over a -55°C to $+125^{\circ}\text{C}$ temperature range.

Features

- Full compatibility with EIA Standards RS232-C, RS422 and RS423, Federal Standards 1020, 1030 and MIL-188-114
- Input voltage range of ± 15 V (differential or common-mode)
- Separate strobe input for each receiver
- $1/2 V_{CC}$ strobe threshold for CMOS compatibility
- 5k typical input impedance
- 50 mV input hysteresis
- 200 mV input threshold
- Operation voltage range = 4.5V to 15V
- Separate fail-safe mode

Connection Diagram

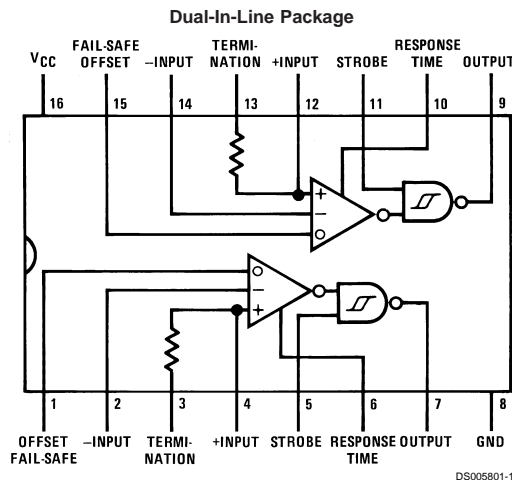

For Complete Military Product Specifications,
refer to the appropriate SMD or MDS.
Order Number DS78C120J/883
See NS Package Number J16A

Absolute Maximum Ratings (Note 2)

If Military/Aerospace specified devices are required, please contact the National Semiconductor Sales Office/Distributors for availability and specifications.

Supply Voltage	18V
Input Voltage	±25V
Strobe Voltage	18V
Output Sink Current	50 mA
Maximum Power Dissipation (Note 1) at 25°C	
Cavity Package	1433 mW
Molded Package	1362 mW

Storage Temperature Range	-65°C to +150°C
Lead Temperature (Soldering, 4 seconds)	260°C

Operating Conditions

	Min	Max	Units
Supply Voltage (V_{CC})	4.5	15	V
Temperature (T_A)			
DS78C120	-55	+125	°C
Common-Mode Voltage (V_{CM})	-15	+15	V

Note 1: Derate cavity package 9.6 mW/°C; derate molded package 10.9 mW/°C above 25°C.

Electrical Characteristics (Notes 3, 4)

Symbol	Parameter	Conditions	Min	Typ	Max	Units
V_{TH}	Differential Threshold Voltage	$I_{OUT} = -200 \mu A$, $V_{OUT} \geq V_{CC} - 1.2V$	$-7V \leq V_{CM} \leq 7V$	0.06	0.2	V
			$-15V \leq V_{CM} \leq 15V$	0.06	0.3	V
V_{TL}	Differential Threshold Voltage	$I_{OUT} = 1.6 mA, V_{OUT} \leq 0.5V$	$-7V \leq V_{CM} \leq 7V$	-0.08	-0.2	V
			$-15V \leq V_{CM} \leq 15V$	-0.08	-0.3	V
V_{TH}	Differential Threshold Voltage Fail-Safe	$I_{OUT} = -200 \mu A$, $V_{OUT} \geq V_{CC} - 1.2V$		0.47	0.7	V
V_{TL}	Offset = 5V	$I_{OUT} = 1.6 mA, V_{OUT} \leq 0.5V$	$-7V \leq V_{CM} \leq 7V$	0.2	0.42	V
R_{IN}	Input Resistance	$-15V \leq V_{CM} \leq 15V, 0V \leq V_{CC} \leq 15V$	4	5		k Ω
R_T	Line Termination Resistance	$T_A = 25^\circ C$	100	180	300	Ω
R_O	Offset Control Resistance	$T_A = 25^\circ C$		56		k Ω
I_{IND}	Data Input Current (Unterminated)	$0V \leq V_{CC} \leq 15V$	$V_{CM} = 10V$	2	3.1	mA
			$V_{CM} = 0V$	0	-0.5	mA
			$V_{CM} = -10V$	-2	-3.1	mA
V_{THB}	Input Balance (Note 6)	$I_{OUT} = 200 \mu A, V_{OUT} \geq V_{CC} - 1.2V, R_S = 500\Omega$ $I_{OUT} = 1.6 mA, V_{OUT} \leq 0.5V, R_S = 500\Omega$	$-7V \leq V_{CM} \leq 7V$	0.1	0.4	V
			$-7V \leq V_{CM} \leq 7V$	-0.1	-0.4	V
V_{OH}	Logical "1" Output Voltage	$I_{OUT} = -200 \mu A, V_{DIFF} = 1V$	$V_{CC} - 1.2$	$V_{CC} - 0.75$		V
V_{OL}	Logical "0" Output Voltage	$I_{OUT} = 1.6 mA, V_{DIFF} = -1V$		0.25	0.5	V
I_{CC}	Power Supply Current	$15V \leq V_{CM} \leq -15V$, $V_{DIFF} = -0.5V$ (Both Receivers)	$V_{CC} = 5.5V$	8	15	mA
			$V_{CC} = 15V$	15	30	mA
$I_{IN(1)}$	Logical "1" Strobe Input Current	$V_{STROBE} = 15V, V_{DIFF} = 3V$		15	100	μA
$I_{IN(0)}$	Logical "0" Strobe Input Current	$V_{STROBE} = 0V, V_{DIFF} = -3V$		-0.5	-100	μA
V_{IH}	Logical "1" Strobe Input Voltage	$V_{OL} \leq 0.5V, I_{OUT} = 1.6 mA$	$V_{CC} = 5V$	3.5	2.5	V
			$V_{CC} = 10V$	8.0	5.0	V
			$V_{CC} = 15V$	12.5	7.5	V
V_{IL}	Logical "0" Strobe Input Voltage	$V_{OH} V_{CC} - 1.2V$, $I_{OUT} = -200 \mu A$	$V_{CC} = 5V$	2.5	1.5	V
			$V_{CC} = 10V$	5.0	2.0	V
			$V_{CC} = 15V$	7.5	2.5	V
I_{OS}	Output Short-Circuit Current	$V_{OUT} = 0V, V_{CC} = 15V, V_{STROBE} = 0V$, (Note 5)	-5	-20	-40	mA

Note 2: "Absolute Maximum Ratings" are those values beyond which the safety of the device cannot be guaranteed. Except for "Operating Temperature Range" they are not meant to imply that the devices should be operated at these limits. The table of "Electrical Characteristics" provides conditions for actual device operation.

Note 3: Unless otherwise specified min/max limits apply across the -55°C to +125°C temperature range for the DS78C120. All typical values for $T_A = 25^\circ C$, $V_{CC} = 5V$ and $V_{CM} = 0V$.

Electrical Characteristics (Notes 3, 4) (Continued)

Note 4: All currents into device pins shown as positive, out of device pins as negative, all voltages referenced to ground unless otherwise noted. All values shown as max or min on absolute value basis.

Note 5: Only one output at a time should be shorted.

Note 6: Refer to EIA-RS422 for exact conditions.

Switching Characteristics

$V_{CC} = 5V, T_A = 25^\circ C$

Symbol	Parameter	Conditions	Min	Typ	Max	Units
$t_{pd0(D)}$	Differential Input to "0" Output	$C_L = 50 \text{ pF}$		60	100	ns
$t_{pd1(D)}$	Differential Input to "1" Output	$C_L = 50 \text{ pF}$		100	150	ns
$t_{pd0(S)}$	Strobe Input to "0" Output	$C_L = 50 \text{ pF}$		30	70	ns
$t_{pd1(S)}$	Strobe Input to "1" Output	$C_L = 50 \text{ pF}$		100	150	ns

AC Test Circuit and Switching Time Waveforms

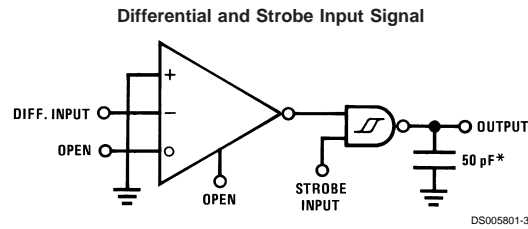

*Includes probe and test fixture capacitance

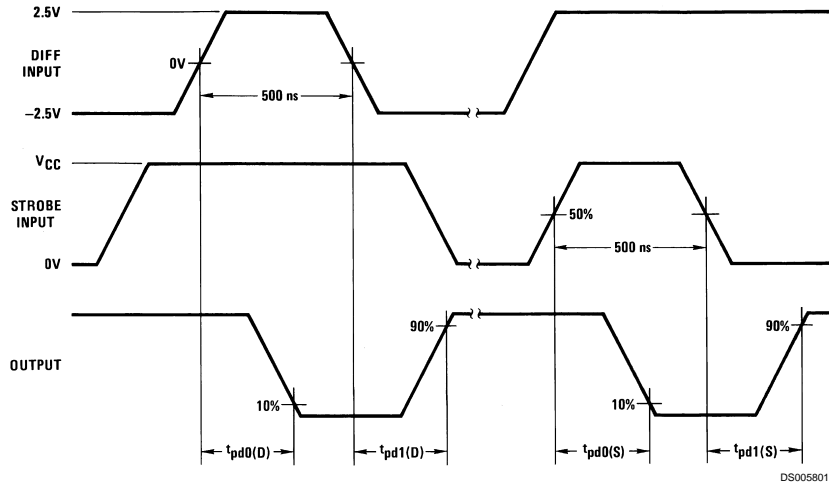

$t_r = t_f \leq 10 \text{ ns}$

PRR = 1 MHz

Note: Optimum switching response is obtained by minimizing stray capacitance on Response Control pin (no external connection).

Schematic Diagram (½ Circuit Shown)

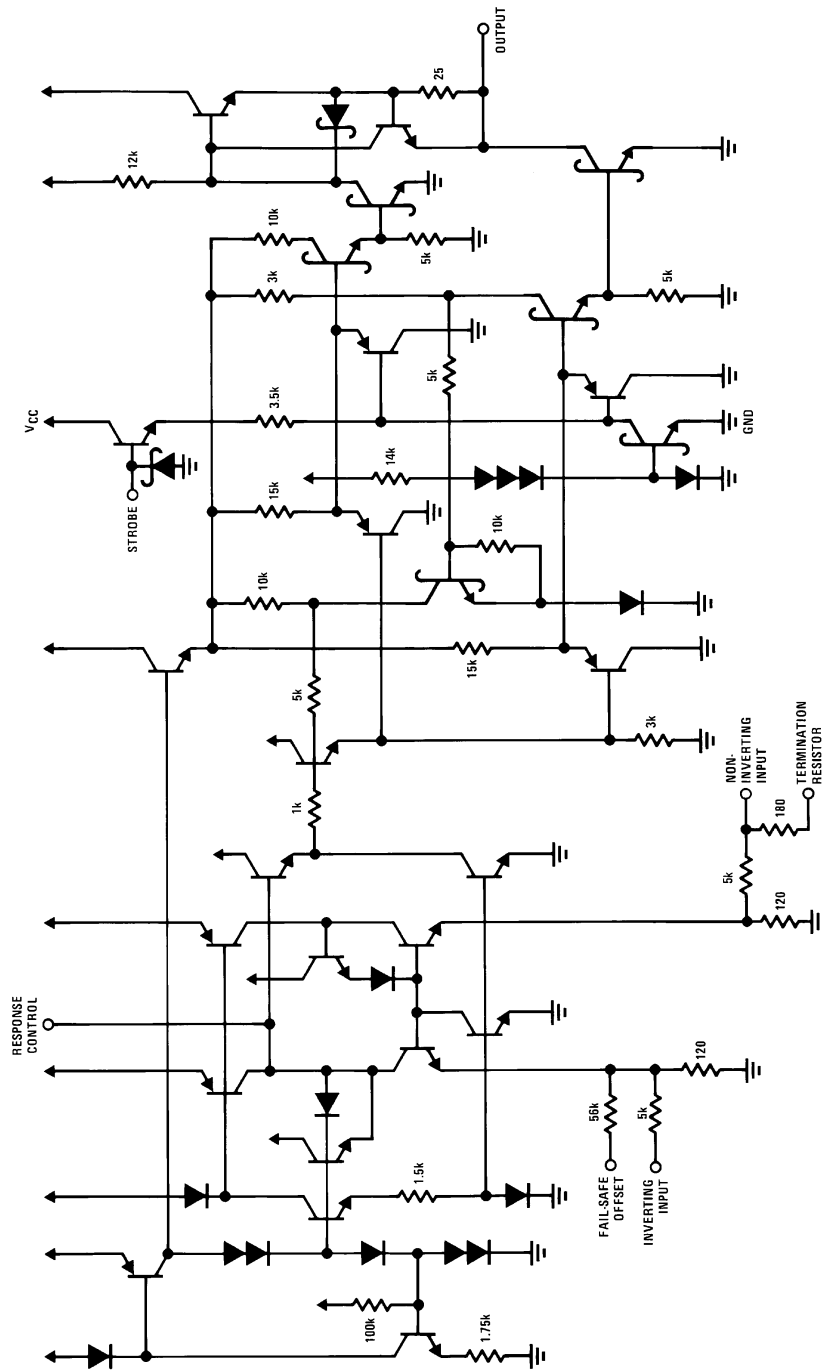

DS90C0601-2

Application Hints

Balanced Data Transmission

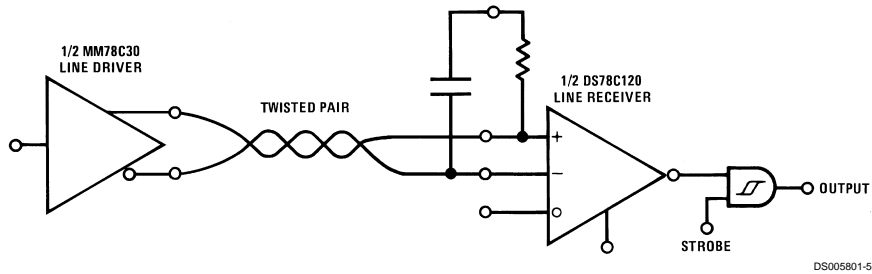

Unbalanced Data Transmission

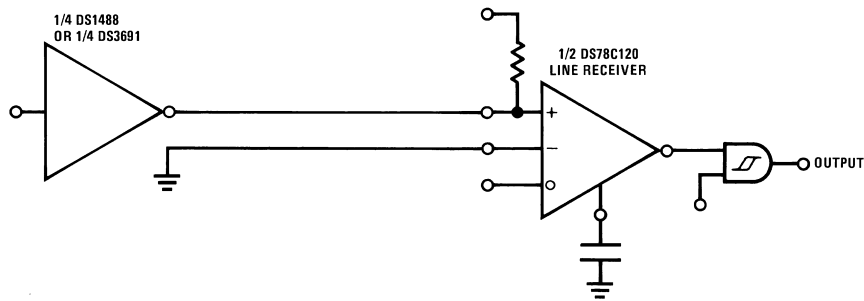

Logic Level Translator

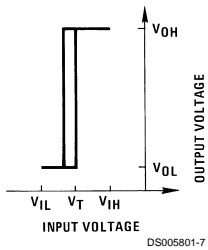
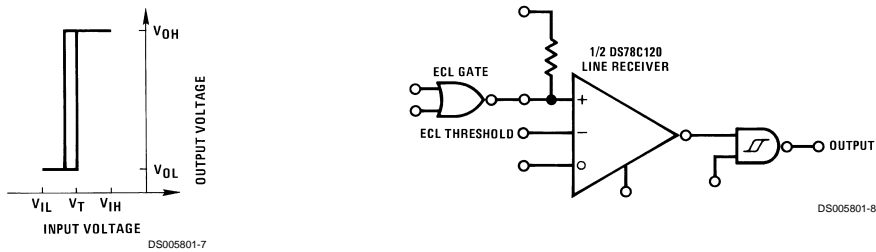

The DS78C120 may be used a level translator to interface between $\pm 12\text{V}$ MOS, ECL, TTL and CMOS. To configure, bias either input to voltage equal to $\frac{1}{2}$ the voltage of the input signal, and the other input to the driving gate.

Application Hints (Continued)

LINE DRIVERS

Line drivers which will interface with the DS78C120 are listed below.

Balanced Drivers

DS26LS31Quad RS-422 Line Driver
 DS7830, DS8830Dual TTL
 DS7831, DS8831Dual TRI-STATE® TTL
 DS7832, DS8832Dual TRI-STATE TTL
 DS1691A, DS3691- Dual RS-422
 DS1692, DS3692 Dual TRI-STATE
 RS-422

DS3587, DS3487Quad TRI-STATE RS-422

Unbalanced Drivers

DS1488Quad RS-232
 DS14C88Quad RS-232
 DS75150Dual RS-232

RESPONSE CONTROL AND HYSTERESIS

In unbalanced (RS-232/RS-423) applications it is recommended that the rise time and fall time of the line driver be controlled to reduce cross-talk. Elimination of switching noise is accomplished in the DS78C120 by the 50 mV of hysteresis incorporated in the output gate. This eliminates the oscillations which may appear in a line receiver due to the input signal slowly varying about the threshold level for extended periods of time.

High frequency noise which is superimposed on the input signal which may exceed 50 mV can be reduced in amplitude by filtering the device input. On the DS78C120, a high impedance response control pin in the input amplifier is available to filter the input signal without affecting the termination impedance of the transmission line. Noise pulse width rejection vs the value of the response control capacitor is shown in *Figure 1* and *Figure 2*. This combination of filters followed by hysteresis will optimize performance in a worse case noise environment.

TRANSMISSION LINE TERMINATION

On a transmission line which is electrically long, it is advisable to terminate the line in its characteristic impedance to prevent signal reflection and its associated noise/cross-talk. A 180Ω termination resistor is provided in the DS78C120 line receiver. To use the termination resistor, connect pins 2 and 3 together and pins 13 and 14 together. The 180Ω resistor provides a good compromise between line reflections, power dissipation in the driver, and IR drop in the transmission line. If power dissipation and IR drop are still a concern, a capacitor may be connected in series with the resistor to minimize power loss.

The value of the capacitor is recommended to be the line length (time) divided by 3 times the resistor value. Example: if the transmission line is 1,000 feet long, (approximately 1000 ns) the capacitor value should be 1852 pF. For additional application details, refer to application notes AN-22 and AN-108.

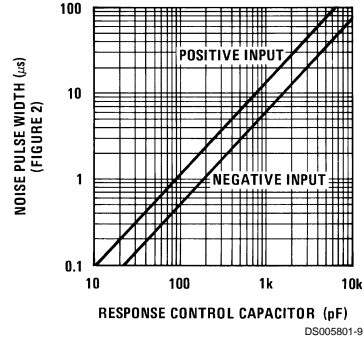

FIGURE 1. Noise Pulse Width vs Response Control Capacitor

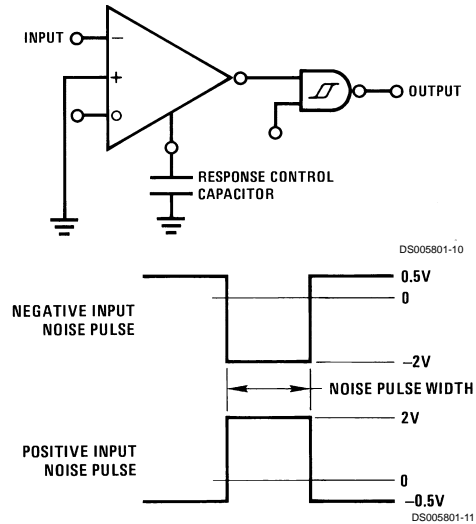

FIGURE 2.

FAIL-SAFE OPERATION

Communication systems require elements of a system to detect the presence of signals in the transmission lines, and it is desirable to have the system shut-down in a fail-safe mode if the transmission line is open or shorted. To facilitate the detection of input opens or shorts, the DS78C120 incorporates an input threshold voltage offset. This feature will force the line receiver to a specific logic state if presence of either fault is a condition.

Given that the receiver input threshold is ± 200 mV, an input signal greater than ± 200 mV insures the receiver will be in a specific logic state. When the offset control input (pins 1 and 15) is connected to $V_{CC} = 5$ V, the input thresholds are offset from 200 mV to 700 mV, referred to the non-inverting input, or -200 mV to -700 mV, referred to the inverting input. Therefore, if the input is open or shorted, the input will be greater than the input threshold and the receiver will remain in a specified logic state.

Application Hints (Continued)

The input circuit of the receiver consists of a 5k resistor terminated to ground through 120Ω on both inputs. This network acts as an attenuator, and permits operation with common-mode input voltages greater than ±15V. The offset control input is actually another input to the attenuator, but its resistor value is 56k. The offset control input is connected to the inverting input side of the attenuator, and the input voltage to the amplifier is the sum of the inverting input plus 0.09 times the voltage on the offset control input. When the offset control input is connected to 5V the input amplifier will see $V_{IN(INVERTING)} + 0.45V$ or $V_{IN(INVERTING)} + 0.9V$ when the control input is connected to 10V. The offset control input will not significantly affect the differential performance of the receiver over its common-mode operating range, and will not change the input impedance balance of the receiver.

It is recommended that the receiver be terminated (500Ω or less) to insure it will detect an open circuit in the presence of noise.

The offset control can be used to insure fail-safe operation for unbalanced interface (RS-423) or for balanced interface (RS-422) operation.

For unbalanced operation, the receiver would be in an indeterminate logic state if the offset control input was open. Connecting the offset to 5V offsets the receiver threshold 0.45V. The output is forced to a logic zero state if the input is open or shorted.

For balanced operation with inputs shorted or open, receiver C will be in an indeterminate logic state. Receivers A and B will be in a logic zero state allowing the NOR gate to detect the short or open condition. The strobe will disable receivers A and B and may therefore be used to sample the fail-safe detector. Another method of fail-safe detection consists of filtering the output of the NOR gate D so it would not indicate a fault condition when receiver inputs pass through the threshold region, generating an output transient.

In a communications system, only the control signals are required to detect input fault condition. Advantages of a balanced data transmission system over an unbalanced transmission system are:

1. High noise immunity
2. High data ratio
3. Long line lengths

Unbalanced RS-423 and RS-232 Fail-Safe

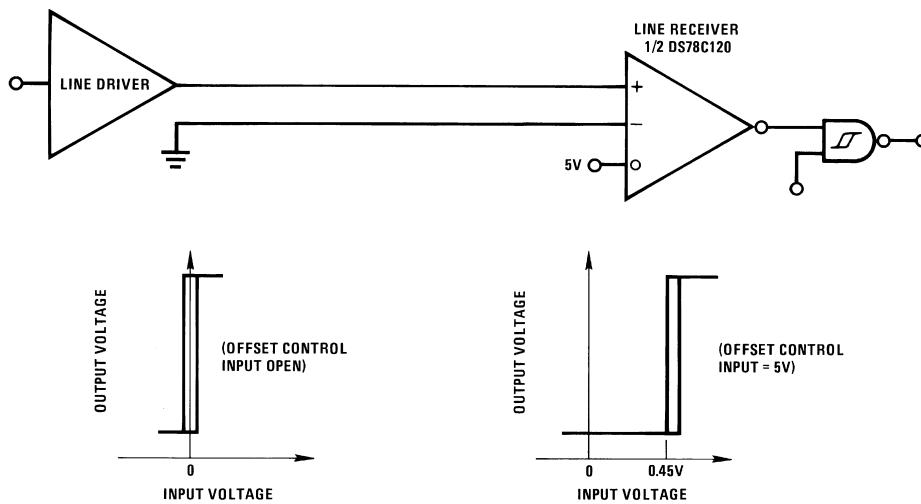

DS005801-12

Application Hints (Continued)

Balanced RS-422 Fail Safe

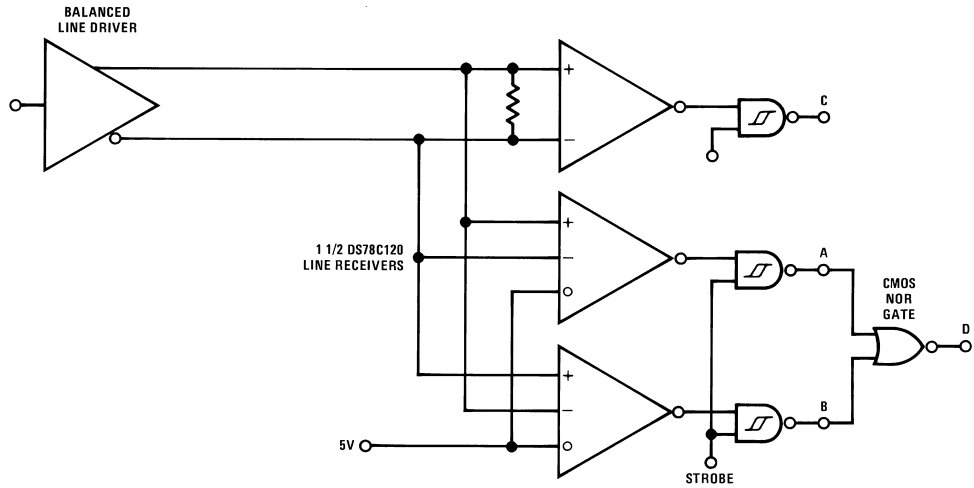

DS005801-13

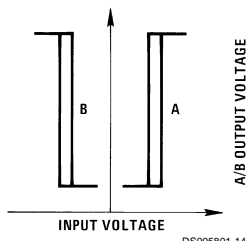

DS005801-14

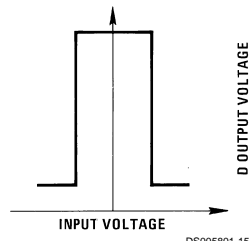

DS005801-15

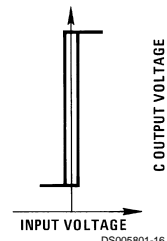

DS005801-16

Truth Table

(For Balanced Fail-Safe)

Input	Strobe	A-OUT	B-OUT	C-OUT	D-OUT
0	1	0	1	0	0
1	1	1	0	1	0
X	1	0	0	X	1
0	0	1	1	0	0
1	0	1	1	0	0
X	0	1	1	0	0

Physical Dimensions inches (millimeters) unless otherwise noted

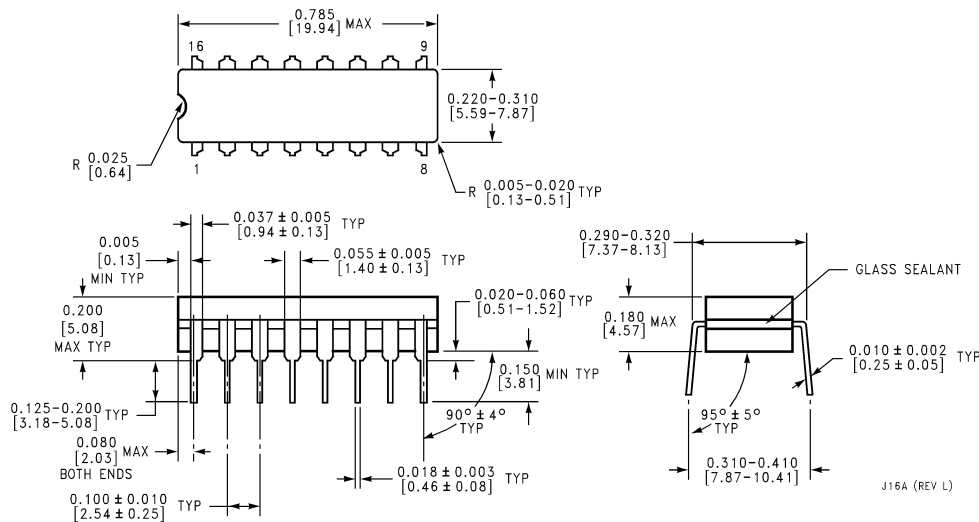

Ceramic Dual-In-Line Package (J)
Order Number DS78C120J/883
NS Package Number J16A

LIFE SUPPORT POLICY

NATIONAL'S PRODUCTS ARE NOT AUTHORIZED FOR USE AS CRITICAL COMPONENTS IN LIFE SUPPORT DEVICES OR SYSTEMS WITHOUT THE EXPRESS WRITTEN APPROVAL OF THE PRESIDENT AND GENERAL COUNSEL OF NATIONAL SEMICONDUCTOR CORPORATION. As used herein:

1. Life support devices or systems are devices or systems which, (a) are intended for surgical implant into the body, or (b) support or sustain life, and whose failure to perform when properly used in accordance with instructions for use provided in the labeling, can be reasonably expected to result in a significant injury to the user.
2. A critical component is any component of a life support device or system whose failure to perform can be reasonably expected to cause the failure of the life support device or system, or to affect its safety or effectiveness.

National Semiconductor Corporation
 Americas
 Tel: 1-800-272-9959
 Fax: 1-800-737-7018
 Email: support@nsc.com

National Semiconductor Europe
 Fax: +49 (0) 1 80-530 85 86
 Email: europe.support@nsc.com
 Deutsch Tel: +49 (0) 1 80-530 85 85
 English Tel: +49 (0) 1 80-532 78 32
 Français Tel: +49 (0) 1 80-532 93 58
 Italiano Tel: +49 (0) 1 80-534 16 80

National Semiconductor Asia Pacific Customer Response Group
 Tel: 65-2544466
 Fax: 65-2504466
 Email: sea.support@nsc.com

National Semiconductor Japan Ltd.
 Tel: 81-3-5639-7560
 Fax: 81-3-5639-7507

www.national.com