

LMX2502/LMX2512 PLLatinum™ Frequency Synthesizer System with Integrated VCO

General Description

LMX2502 and LMX2512 are highly integrated, high performance, low power frequency synthesizer systems optimized for Korean PCS and Korean Cellular CDMA (1xRTT, IS-95) mobile handsets. Using a proprietary digital phase locked loop technique, LMX2502 and LMX2512 generate very stable, low noise local oscillator signals for up and down conversion in wireless communications devices.

LMX2502 and LMX2512 include a voltage controlled oscillator (VCO), a loop filter, and a fractional-N RF PLL based on a delta sigma modulator. In concert these blocks form a closed loop RF synthesizer system. LMX2502 supports the Korean PCS band and LMX2512 supports the Korean Cellular band.

LMX2502 and LMX2512 include an Integer-N IF PLL also. For more flexible loop filter designs, the IF PLL includes a 4-level programmable charge pump. Together with an external VCO and loop filter, LMX2502 and LMX2512 make a complete closed loop IF synthesizer system.

Serial data is transferred to the device via a three-wire MICROWIRE interface (DATA, LE, CLK).

Operating supply voltage ranges from 2.7 V to 3.3 V. LMX2502 and LMX2512 feature low current consumption: 17 mA at 2.8 V.

LMX2502 and LMX2512 are available in a 28-pin leadless leadframe package (LLP).

Features

- Small Size
5.0 mm X 5.0 mm X 0.75 mm 28-Pin LLP Package
- RF Synthesizer System
Integrated RF VCO
Integrated Loop Filter
Low Spurious, Low Phase Noise Fractional-N RF PLL
Based on 11-Bit Delta Sigma Modulator
10 kHz Frequency Resolution
- IF Synthesizer System
Integer-N IF PLL
Programmable Charge Pump Current Levels
Programmable Frequency
- Supports Various Reference Frequencies
19.20/19.68 MHz
- Fast Lock Time: 500 μ s
- Low Current Consumption
17 mA at 2.8 V
- 2.7 V to 3.3 V Operation
- Digital Filtered Lock Detect Output
- Hardware and Software Power Down Control

Applications

- Korean PCS CDMA Systems
- Korean Cellular CDMA Systems

Functional Block Diagram

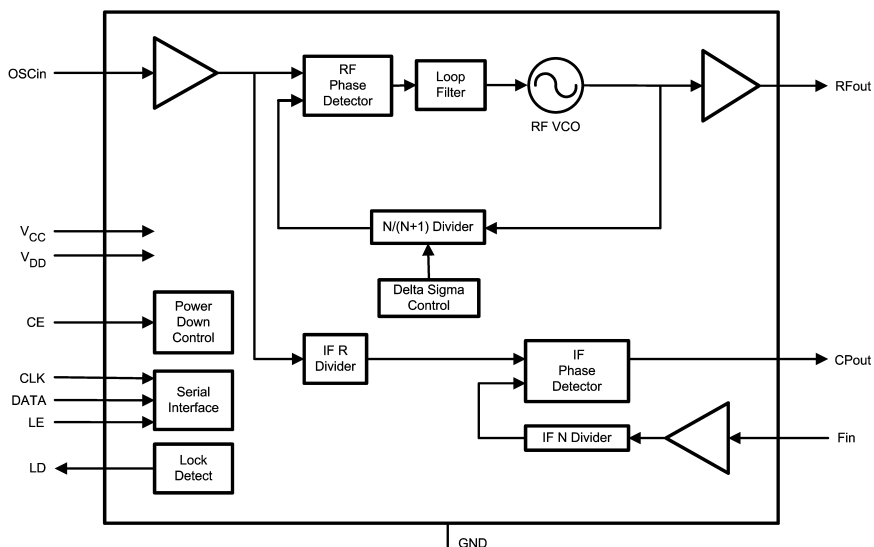

20068001

PLLatinum™ is a trademark of National Semiconductor Corporation.

Connection Diagram

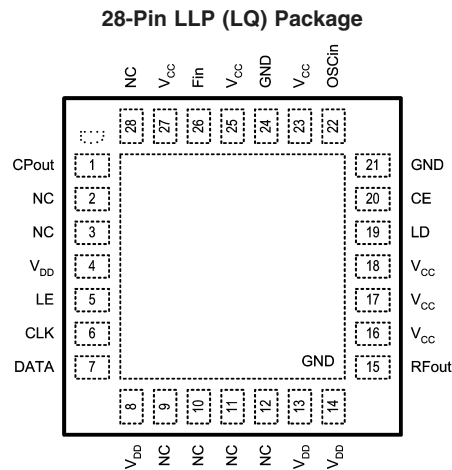

20068002

NOTE: Analog ground connected through exposed die attached pad.

Pin Descriptions

Pin Number	Name	I/O	Description
1	CPout	O	IF PLL charge pump output
2	NC	–	Do not connect to any node on the printed circuit board.
3	NC	–	Do not connect to any node on the printed circuit board.
4	V _{DD}	–	Supply voltage for IF analog circuitry
5	LE	I	MICROWIRE Latch Enable
6	CLK	I	MICROWIRE Clock
7	DATA	I	MICROWIRE Data
8	V _{DD}	–	Supply voltage for VCO
9	NC	–	Do not connect to any node on the printed circuit board.
10	NC	–	Do not connect to any node on the printed circuit board.
11	NC	–	Do not connect to any node on the printed circuit board.
12	NC	–	Do not connect to any node on the printed circuit board.
13	V _{DD}	–	Supply voltage for VCO
14	V _{DD}	–	Supply voltage for VCO output buffer
15	RFout	O	Buffered VCO output
16	V _{CC}	–	Supply voltage for RF prescaler
17	V _{CC}	–	Supply voltage for charge pump
18	V _{CC}	–	Supply voltage for RF digital circuitry
19	LD	O	Lock Detect
20	CE	I	Chip Enable control pin
21	GND	–	Ground for digital circuitry
22	OSCin	I	Reference frequency input
23	V _{CC}	–	Supply voltage for reference input buffer
24	GND	–	Ground for digital circuitry
25	V _{CC}	–	Supply voltage for IF digital circuitry
26	Fin	I	IF buffer/prescaler input
27	V _{CC}	–	Supply voltage for IF buffer/prescaler
28	NC	–	Do not connect to any node on the printed circuit board.

Ordering Information

Part Number	RF Min. (MHz)	RF Max. (MHz)	RF Center (MHz)	IF (MHz)	Package Marking	Supplied As
LMX2502LQX1635	1619.62	1649.62	~1635	440.76	25021635	4500 units on tape and reel
LMX2502LQ1635	1619.62	1649.62	~1635	440.76	25021635	1000 units on tape and reel
LMX2512LQX0967	954.42	979.35	~967	170.76	25120967	4500 units on tape and reel
LMX2512LQ0967	954.42	979.35	~967	170.76	25120967	1000 units on tape and reel
LMX2512LQX1065	1052.64	1077.57	~1065	367.20	25121065	4500 units on tape and reel
LMX2512LQ1065	1052.64	1077.57	~1065	367.20	25121065	1000 units on tape and reel

Part Number Description

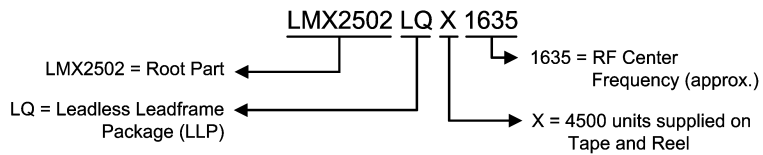

20068003

Absolute Maximum Ratings (Notes 1, 2, 3)

If Military/Aerospace specified devices are required, please contact the National Semiconductor Sales Office/Distributors for availability and specifications.

Parameter	Symbol	Ratings	Units
Supply Voltage	V_{CC}, V_{DD}	-0.3 to 3.6	V
Voltage on any pin to GND	V_I	-0.3 to $V_{CC}+0.3$	V
		-0.3 to $V_{DD}+0.3$	V
Storage Temperature Range	T_{STG}	-65 to 150	°C

Recommended Operating Conditions

Parameter	Symbol	Min	Typ	Max	Units
Ambient Temperature	T_A	-30	25	85	°C
Supply Voltage (to GND)	V_{CC}, V_{DD}	2.7		3.3	V

Note 1: Absolute Maximum Ratings indicate limits beyond which damage to the device may occur. Recommended Operating Conditions indicate conditions for which the device is intended to be functional, but do not guarantee specific performance limits. For guaranteed specifications and test conditions, refer to the Electrical Characteristics section. The guaranteed specifications apply only for the conditions listed.

Note 2: This device is a high performance RF integrated circuit with an ESD rating < 2 kV and is ESD sensitive. Handling and assembly of this device should be done at ESD protected work stations.

Note 3: GND = 0 V.

Electrical Characteristics ($V_{CC} = V_{DD} = 2.8$ V, $T_A = 25$ °C; unless otherwise noted)

Symbol	Parameter	Condition	Min	Typ	Max	Units	
I_{CC} PARAMETERS							
$I_{CC} + I_{DD}$	Total Supply Current	OB_CRL [1:0] = 00		17	19	mA	
$(I_{CC} + I_{DD})_{RF}$	RF PLL Total Supply Current	OB_CRL [1:0] = 00		16	18	mA	
I_{PD}	Power Down Current (Note 4)	CE = LOW or RF_EN = 0 IF_EN = 0			20	µA	
REFERENCE OSCILLATOR PARAMETERS							
f_{OSCin}	Reference Oscillator Input Frequency (Note 5)	19.20 MHz and 19.68 MHz are supported	19.20		19.68	MHz	
V_{OSCin}	Reference Oscillator Input Sensitivity			0.2	V_{CC}	Vp-p	
RF VCO							
f_{RFout}	Frequency Range (Note 6)	LMX2502LQ1635	RF VCO	1619.62		1649.62	MHz
		LMX2512LQ0967		954.42		979.35	MHz
		LMX2512LQ1065		1052.64		1077.57	MHz
P_{RFout}	RF Output Power		OB_CRL [1:0] = 11	-2	1	4	dBm
			OB_CRL [1:0] = 10	-5	-2	1	dBm
			OB_CRL [1:0] = 01	-7	-4	-1	dBm
			OB_CRL [1:0] = 00	-9	-6	-3	dBm
	Lock Time (Note 7)	LMX2502LQ1635	30 MHz Band for RF PLL		500	800	µs
		LMX2512LQ0967	25 MHz Band for RF PLL		500	800	µs
		LMX2512LQ1065	25 MHz Band for RF PLL		500	800	µs
	Reference Spurs					-75	dBc
	RMS Phase Error	RF PLL in all band		1.3			degrees
$L(f)_{RFout}$	Phase Noise	LMX2502LQ1635	@ 100 kHz offset		-113	-112	dBc/Hz
			@ 1.25 MHz offset		-138	-136	dBc/Hz
		LMX2512LQ0967	@ 100 kHz offset		-117	-115	dBc/Hz
			@ 900 kHz offset		-139	-138	dBc/Hz
		LMX2512LQ1065	@ 100 kHz offset		-117	-115	dBc/Hz
			@ 900 kHz offset		-139	-138	dBc/Hz
	2nd Harmonic Suppression					-25	dBc
	3rd Harmonic Suppression					-20	dBc

Electrical Characteristics ($V_{CC} = V_{DD} = 2.8\text{ V}$, $T_A = 25\text{ }^\circ\text{C}$; unless otherwise noted) (Continued)

Symbol	Parameter	Condition	Min	Typ	Max	Units
IF PLL						
f_{Fin}	Operating Frequency (Note 8)	LMX2502LQ1635	IF_FREQ [1:0] = 10, Default Value		440.76	MHz
		LMX2512LQ0967	IF_FREQ [1:0] = 00, Default Value		170.76	MHz
		LMX2512LQ1065	IF_FREQ [1:0] = 01, Default Value		367.20	MHz
P_{Fin}	IF Input Sensitivity		-10		0	dBm
$f_{\Phi IF}$	Phase Detector Frequency			120		kHz
I_{CPout}	Charge Pump Current		IF_CUR [1:0] = 00		100	μA
			IF_CUR [1:0] = 01		200	μA
			IF_CUR [1:0] = 10		300	μA
			IF_CUR [1:0] = 11		800	μA
DIGITAL INTERFACE (DATA, CLK, LE, LD, CE)						
V_{IH}	High-Level Input Voltage		$0.8 V_{DD}$		V_{DD}	V
			$0.8 V_{CC}$		V_{CC}	V
V_{IL}	Low-Level Input Voltage		0		$0.2 V_{DD}$	V
			0		$0.2 V_{CC}$	V
I_{IH}	High-Level Input Current		-10		10	μA
I_{IL}	Low-Level Input Current		-10		10	μA
	Input Capacitance			3		pF
V_{OH}	High-Level Output Voltage		$0.9 V_{DD}$			V
			$0.9 V_{CC}$			V
V_{OL}	Low-Level Output Voltage				$0.1 V_{DD}$	V
					$0.1 V_{CC}$	V
	Output Capacitance				5	pF
MICROWIRE INTERFACE TIMING						
t_{CS}	Data to Clock Set Up Time		50	-	-	ns
t_{CH}	Data to Clock Hold Time		10	-	-	ns
t_{CWH}	Clock Pulse Width HIGH		50	-	-	ns
t_{CWL}	Clock Pulse Width LOW		50	-	-	ns
t_{ES}	Clock to Latch Enable Set Up Time		50	-	-	ns
t_{EW}	Latch Enable Pulse Width		50	-	-	ns

Note 4: In power down mode, set DATA, CLK, and LE pins to 0 V (GND).

Note 5: The reference frequency must also be programmed using the OSC_FREQ control bit. For other reference frequencies, please contact National Semiconductor.

Note 6: For other frequency ranges, please contact National Semiconductor.

Note 7: Lock time is defined as the time difference between the beginning of the frequency transition and the point at which the frequency remains within +/- 1 kHz of the final frequency.

Note 8: Frequencies other than the default value can be programmed using Words R4 and R5. See Programming Description for details.

Microwire Interface Timing Diagram

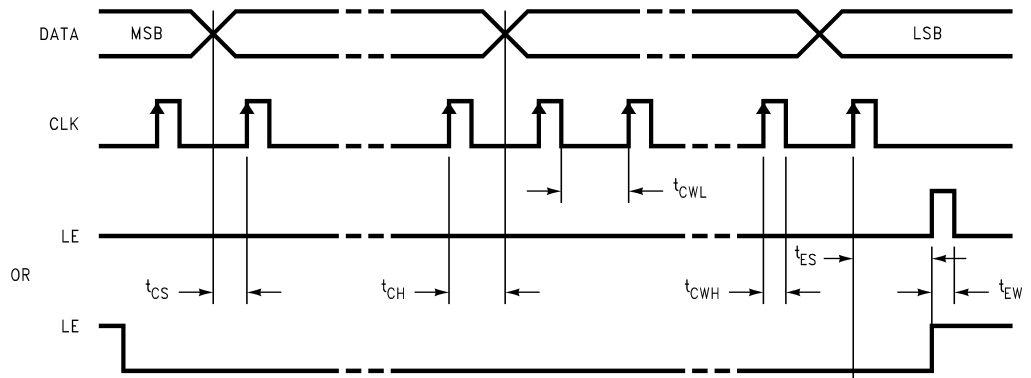

20068004

Functional Description

GENERAL DESCRIPTION

LMX2502/12 is a highly integrated frequency synthesizer system that generates LO signals for PCS and Cellular CDMA applications. These devices include all the functional blocks of a PLL, RF VCO, prescaler, RF phase detector, and loop filter. The need for external components is limited to a few passive elements for matching the output impedance and bypass elements for power line stabilization.

In addition to the RF circuitry, the IC also includes IF frequency dividers, and an IF phase detector to complete the IF synthesis with the external VCO and the loop filter. *Table 1* summarizes the counter values used to generate the default IF frequencies.

Using a low spurious fractional-N synthesizer based on a delta sigma modulator, the circuit can support 10 kHz channel spacing for PCS and Cellular CDMA systems.

The fractional-N synthesizer enables faster lock time, which reduces power consumption and system set-up time. Additionally, the loop filter occupies a smaller area as opposed to the integer-N architecture. This allows the loop filter to be embedded into the circuit, minimizing the external noise coupling and total form factor. The delta sigma architecture delivers very low spurious, which can be a significant problem for other PLL solutions.

The circuit also supports commonly used reference frequencies of 19.20 MHz and 19.68 MHz.

FREQUENCY GENERATION

RF-PLL Section

The divide ratio can be calculated using the following equation:

LMX2502 – PCS CDMA:

$$f_{VCO} = \{8 \times RF_B + RF_A + (RF_FN / f_{OSC}) \times 10^4\} \times f_{OSC}$$

where (RF_A < RF_B)

LMX2512 – Cellular CDMA:

$$f_{VCO} = \{6 \times RF_B + RF_A + (RF_FN / f_{OSC}) \times 10^4\} \times f_{OSC}$$

where (RF_A < RF_B)

where

f_{VCO} : Output frequency of voltage controlled oscillator (VCO)

RF_B: Preset divide ratio of binary 4-bit programmable counter ($2 \leq RF_B \leq 15$)

RF_A: Preset divide ratio of binary 3-bit swallow counter ($0 \leq RF_A \leq 7$ for LMX2502 or $0 \leq RF_A \leq 5$ for LMX2512)

RF_FN: Preset numerator of binary 11-bit modulus counter ($0 \leq RF_FN < 1920$ for $f_{OSC} = 19.20$ MHz or $0 \leq RF_FN < 1968$ for $f_{OSC} = 19.68$ MHz)

f_{OSC} : Reference oscillator frequency

IF-PLL Section

$$f_{VCO} = \{16 \times IF_B + IF_A\} \times f_{OSC} / IF_R$$

where

f_{VCO} : Output frequency of the voltage controlled oscillator (VCO)

IF_B: Preset divide ratio of the binary 9-bit programmable counter ($1 \leq IF_B \leq 511$)

IF_A: Preset divide ratio of the binary 4-bit swallow counter ($0 \leq IF_A \leq 15$)

f_{OSC} : Reference oscillator frequency

IF_R: Preset divide ratio of the binary 9-bit programmable reference counter ($2 \leq IF_R \leq 511$)

From the above equation, the LMX2502/12 generates the fixed IF frequencies as summarized in *Table 1*.

TABLE 1. IF Frequencies

Device Type	F _{VCO} (MHz)	IF_B	IF_A	f _{OSC} /IF_R (kHz)
LMX2502LQ1635	440.76	229	9	120
LMX2512LQ0967	170.67	88	15	120
LMX2512LQ1065	367.20	191	4	120

VCO FREQUENCY TUNING

The center frequency of the RF VCO is determined by the resonant frequency of the tank circuit. This tank circuit is implemented on-chip and requires no external inductor. The LMX2502/12 actively tunes the tank circuit to the required frequency with the built-in tracking algorithm.

BANDWIDTH CONTROL AND FREQUENCY LOCK

During the frequency acquisition period, the loop bandwidth is significantly extended to achieve frequency lock. Once frequency lock occurs, the PLL will return to a steady state condition with the loop bandwidth set to its nominal value. The transition between acquisition and lock modes occurs seamlessly and extremely fast, thereby, meeting the stringent requirements associated with lock time and phase noise. Several controls (BW_DUR, BW_CRL, and BW_EN) are used to optimize the lock time performance.

SPURIOUS REDUCTION

To improve the spurious performance of the device one of two types of spurious reduction schemes can be selected:

- A continuous optimization scheme, which tracks the environmental and voltage variations, giving the best spurious performance over changing conditions
- A one time optimization scheme, which sets the internal compensation values only when the PLL goes into a locked state.

The spurious reduction can also be disabled, but it is recommended that the continuous optimization mode be used for normal operation.

POWER DOWN MODE

The LMX2502 and LMX2512 include a power down mode to reduce the power consumption. The LMX2502/12 enters into the power down mode either by taking the CE pin LOW or by setting the power down bits in Register R1. *Table 2* summarizes the power down function. If CE is set LOW, the circuit is powered down regardless of the register values. When CE is HIGH, the IF and RF circuitry are individually powered down by setting the register bits.

Functional Description (Continued)

TABLE 2. Power Down Configuration

CE Pin	RF_EN	IF_EN	RF Circuitry	IF Circuitry
0	X	X	OFF	OFF
1	0	0	OFF	OFF
1	0	1	OFF	ON
1	1	0	ON	OFF
1	1	1	ON	ON

X = Don't care.

LOCK DETECT

The LD output can be used to indicate the lock status of the RF PLL. Bit 21 in Register R0 determines the signal that appears on the LD pin. When the RF PLL is not locked, the

LD pin remains LOW. After obtaining phase lock, the LD pin will have a logical HIGH level. The output can also be programmed to be ground at all times.

TABLE 3. Lock Detect Modes

LD Bit	Mode
0	Disable (GND)
1	Enable

TABLE 4. Lock Detect Logic

RF PLL Section	LD Output
Locked	HIGH
Not Locked	LOW

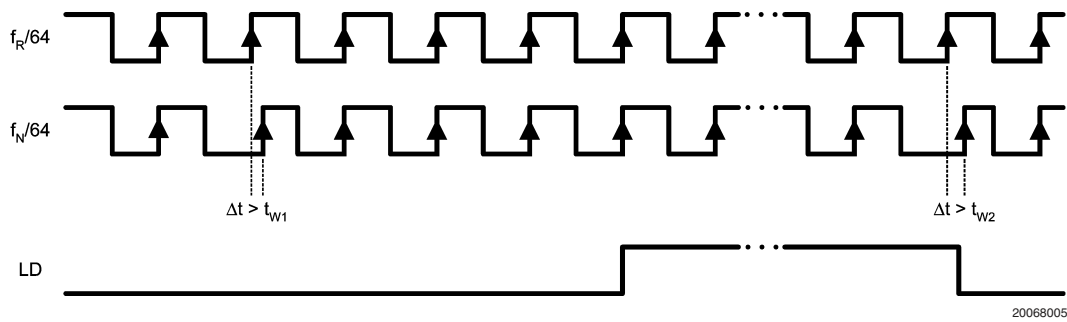

FIGURE 1. Lock Detect Timing Diagram Waveform (Notes 9, 10, 11, 12, 13)

Note 9: LD output becomes LOW when the phase error is larger than t_{W2} .

Note 10: LD output becomes HIGH when the phase error is less than t_{W1} for four or more consecutive cycles.

Note 11: Phase Error is measured on leading edge. Only errors greater than t_{W1} and t_{W2} are labeled.

Note 12: t_{W1} and t_{W2} are equal to 10 ns.

Note 13: The lock detect comparison occurs with every 64th cycle of f_R and f_N .

Functional Description (Continued)

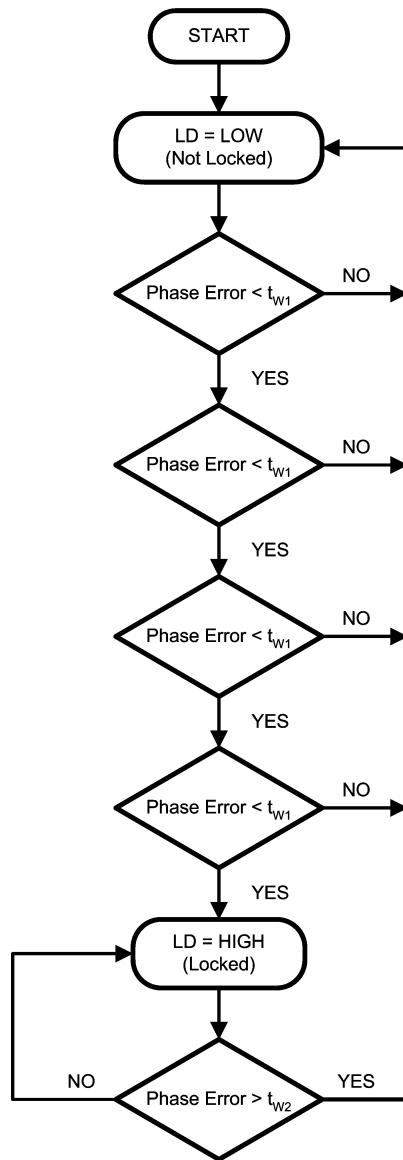

20068006

FIGURE 2. Lock Detect Flow Diagram

MICROWIRE INTERFACE

The programmable register set is accessed via the MICROWIRE serial interface. The interface comprises three signal pins: CLK, DATA, and LE (Latch Enable). Serial data (DATA) is clocked into the 24-bit shift register on the rising

edge of the clock (CLK). The last bits decode the internal control register address. When the latch enable (LE) transitions from LOW to HIGH, data stored in the shift registers is loaded into the corresponding control register.

Programming Description

GENERAL PROGRAMMING INFORMATION

The serial interface has a 24-bit shift register to store the incoming data bits temporarily. The incoming data is loaded into the shift register from MSB to LSB. The data is shifted at the rising edge of the clock signal. When the latch enable signal transitions from LOW to HIGH, the data stored in the shift register is transferred to the proper register depending on the address bit settings. The selection of the particular register is determined by the address bits equal to the binary representation of the number of the control register.

At initial start-up, the MICROWIRE loading requires 4 default words (registers R3, loaded first, to R0, loaded last). After the device has been initially programmed, the RF VCO frequency can be changed using a single register (R0). If an IF frequency other than the default value for the device is desired the SPI_DEF bit should be set to 0, the desired values for IF_A, IF_B, and IF_R entered and words R6 to R0 should be sent.

The control register content map describes how the bits within each control register are allocated to the specific control functions.

COMPLETE REGISTER MAP

Register	SHIFT REGISTER BIT LOCATION																				LSB					
	23	22	21	20	19	18	17	16	15	14	13	12	11	10	9	8	7	6	5	4		3	2	1	0	
R0 (Default)	SPI_DEF	RF_SEL	RF_LD	0	RF_B [3:0]			RF_A [2:0]			RF_FN [10:0]										0	0				
R1 (Default)	IF_FREQ [1:0]		OSC_FREQ	1	0	0	0	0	0	0	0	SPUR_RDT [1:0]		0	0	1	0	1	OB_CRL [1:0]		RF_EN	IF_EN	0	1		
R2 (Default)	IF_CUR [1:0]		0	0	1	0	0	1	1	1	0	1	1	0	1	0	1	0	1	0	0	1	0	1	0	
R3 (Default)	BW_DUR [1:0]		BW_CRL [1:0]		BW_EN		1	0	1	1	1	1	0	1	0	0	0	1	1	0	VCO_CUR [1:0]		0	1	1	
R4	0	0	0	1	0	0	0	IF_A [3:0]			IF_B [8:0]						0	1	1	1						
R5	0	0	1	1	0	0	0	0	1	0	IF_R [8:0]						0	1	1	1	1					
R6	1	0	0	0	0	0	0	0	0	0	0	0	0	0	0	0	0	0	0	0	0	1	1	1	1	1

NOTE: **Bold** numbers represent the address bits.

Programming Description (Continued)

R0 REGISTER

The R0 register address bits (R0 [1:0]) are “00”.

The SPI_DEF bit selects between using the default IF counter values and user programmable values. The use of the default counter values requires that only words R0 to R3 (registers R3, loaded first, to R0, loaded last) be sent after initial power up.

The RF_LD bit activates the lock detect output of the LD pin (pin 19). The lock detect mode shows the lock status of the RF PLL. The waveform of the lock detect mode is shown in *Figure 1*, in the **Functional Description** section on **LOCK DETECT**.

The RF N counter consists of the 4-bit programmable counter (RF_B counter), the 3-bit swallow counter (RF_A counter) and the 11-bit delta sigma modulator (RF_FN counter). The equations for calculating the counter values are presented below.

R0 REGISTER

Register	MSB		SHIFT REGISTER BIT LOCATION																	LSB				
	23	22	21	20	19	18	17	16	15	14	13	12	11	10	9	8	7	6	5	4	3	2	1	0
	Data Field																						Address Field	
R0 (Default)	SPI_DEF	RF_SEL	RF_LD	0	RF_B [3:0]			RF_A [2:0]			RF_FN [10:0]										0	0		

Name	Functions
SPI_DEF	Default Register Selection 0 = OFF (Use values set in R0 to R6) 1 = ON (Use default values set in R0 to R3)
RF_SEL	RF VCO Selection 0 = LMX2512 1 = LMX2502
RF_LD	RF Lock Detect 0 = Hard zero (GND) 1 = Lock detect
RF_B [3:0]	RF_B Counter 4-bit programmable counter $2 \leq RF_B \leq 15$
RF_A [2:0]	RF_A Counter 3-bit swallow counter $0 \leq RF_A \leq 7$ for LMX2502 $0 \leq RF_A \leq 5$ for LMX2512
RF_FN [10:0]	RF Fractional Numerator Counter 11-bit programmable counter $0 \leq RF_FN < 1920$ for $f_{OSC} = 19.20$ MHz $0 \leq RF_FN < 1968$ for $f_{OSC} = 19.68$ MHz

Programming Description (Continued)

RF N Counter Setting:

Counter Name	Symbol	Function
Modulus Counter	RF_FN	RF N Divider $N = \text{Prescaler} \times \text{RF_B} + \text{RF_A} + (\text{RF_FN} / f_{\text{OSC}}) \times 10^4$
Programmable Counter	RF_B	
Swallow Counter	RF_A	

Pulse Swallow Function:

$$f_{\text{VCO}} = \{\text{Prescaler} \times \text{RF_B} + \text{RF_A} + (\text{RF_FN} / f_{\text{OSC}}) \times 10^4\} \times f_{\text{OSC}} \text{ where } (\text{RF_A} < \text{RF_B})$$

where

f_{VCO} : Output frequency of voltage controlled oscillator (VCO)

Prescaler Values:

Device Type	RF Prescaler
LMX2502	8
LMX2512	6

RF_B: Preset divide ratio of binary 4-bit programmable counter ($2 \leq \text{RF_B} \leq 15$)

RF_A: Preset divide ratio of binary 3-bit swallow counter ($0 \leq \text{RF_A} \leq 7$ for LMX2502, $0 \leq \text{RF_A} \leq 5$ for LMX2512)

RF_FN: Preset numerator of binary 11-bit modulus counter ($0 \leq \text{RF_FN} < 1920$ for $f_{\text{OSC}} = 19.20$ MHz; $0 \leq \text{RF_FN} < 1968$ for $f_{\text{OSC}} = 19.68$ MHz).

f_{OSC} : Reference oscillator frequency

NOTE: For the use of reference frequencies other than those specified, please contact National Semiconductor.

Programming Description (Continued)

R1 REGISTER

The R1 register address bits (R1 [1:0]) are "01".

The IF_FREQ bits selects the default IF frequency applicable to the specific CDMA system. For the LMX2502 the default IF frequency is 440.76 MHz, and for the LMX2512 the default IF frequencies are 367.20 MHz and 170.76 MHz, depending on variant.

Reference Frequency Selection bit (OSC_FREQ) selects either 19.20 MHz or 19.68 MHz for the reference oscillator frequency.

The internal spurious reduction scheme is controlled by the SPUR_RDT [1:0] bits. There are two different spur reduction schemes: a continuous tracking mode and a single optimization mode. The continuous tracking mode will adjust for variations in voltage and temperature. The single optimization mode fixes the internal compensation parameters only when the PLL goes into the locked state. The spur reduction can also be disabled, but it is recommended that the continuous mode be used for normal operation.

The OB_CRL [1:0] bits determine the power level of the RF output buffer. The power level can be set according to the system requirement.

The two bits, RF_EN and IF_EN, logically select the active state of the RF synthesizer system and the IF PLL, respectively. The entire IC can be placed in a power down state by using the CE control pin (pin 20).

R1 REGISTER

Register	SHIFT REGISTER BIT LOCATION																				MSB		LSB		
	23	22	21	20	19	18	17	16	15	14	13	12	11	10	9	8	7	6	5	4	3	2	1	0	
	Data Field																						Address Field		
R1 (Default)	IF_FREQ [1:0]		OSC_FREQ		1	0	0	0	0	0	0	0	0	0	0	0	1	0	1	OB_CRL [1:0]		RF_EN	IF_EN	0	1

Name	Functions
IF_FREQ [1:0]	IF Frequency Selection 00 = 170.76 MHz (LMX2512LQ0967) 01 = 367.20 MHz (LMX2512LQ1065) 10 = 440.76 MHz (LMX2502LQ1635)
OSC_FREQ	Reference Frequency Selection 0 = 19.20 MHz 1 = 19.68 MHz
SPUR_RDT [1:0]	Spur Reduction Scheme 00 = No spur reduction 01 = Not Used 10 = Continuous tracking of variation (Recommended) 11 = One time optimization
OB_CRL [1:0]	RF Output Power Control 00 = Minimum Output Power 01 = 10 = 11 = Maximum Output Power
RF_EN	RF Enable 0 = RF Off 1 = RF On
IF_EN	IF Enable 0 = IF Off 1 = IF On

Programming Description (Continued)

R2 REGISTER

The R2 Register address bits (R2 [1:0]) are “10”.

The IF_CUR [1:0] bits program the IF charge-pump current. Considering the external IF VCO and loop filter, the user can select the amount of IF charge pump current to be 100 μ A, 200 μ A, 300 μ A or 800 μ A.

R2 REGISTER

Register	MSB	SHIFT REGISTER BIT LOCATION																		LSB				
	23	22	21	20	19	18	17	16	15	14	13	12	11	10	9	8	7	6	5	4	3	2	1	0
	Data Field																						Address Field	
R2 (Default)	IF_CUR[1:0]	0	0	1	0	0	1	1	1	1	0	1	1	0	1	0	1	0	0	0	1	0	1	0

Name	Functions
IF_CUR [1:0]	IF Charge Pump Current 00 = 100 μ A 01 = 200 μ A 10 = 300 μ A 11 = 800 μ A

Programming Description (Continued)

R3 REGISTER

The R3 register address bits (R3 [2:0]) are “011”.

Register R3 contains the controls for the phase lock bandwidth controls (BW_DUR, BW_CRL, and BW_EN). The duration of the digital controller portion of the bandwidth control is set by BW_DUR [1:0]. The minimum time set with 00 and increasing durations to the maximum value set with 11. BW_CRL [1:0] sets the phase offset criterion for the bandwidth controller. Once the phase offset between the reference clock and the divided VCO signal are within the set criterion, the bandwidth control stops. The maximum phase offset is set with 00 and decreases to the minimum value set with 11. BW_EN enables the bandwidth control in the locking state.

The VCO dynamic current is also controlled in register R3 with VCO_CUR [1:0]. The minimum value corresponds to 00 and increases to a maximum value set at 11.

R3 REGISTER

Register	SHIFT REGISTER BIT LOCATION																				Address Field					
	MSB	23	22	21	20	19	18	17	16	15	14	13	12	11	10	9	8	7	6	5	4	3	2	1	0	LSB
	Data Field																						Address Field			
R3 (Default)	BW_DUR [1:0]	BW_CRL [1:0]	BW_EN	1	0	1	1	1	1	0	1	0	0	0	0	1	1	0	VCO_CUR [1:0]	0	1	1				

Name	Functions
BW_DUR [1:0]	Bandwidth Duration 00 = Minimum value (Recommended) 01 = 10 = 11 = Maximum value
BW_CRL [1:0]	Bandwidth Control 00 = Maximum phase offset (Recommended) 01 = 10 = 11 = Minimum phase offset
BW_EN	Bandwidth Enable 0 = Disable 1 = Enable (Recommended)
VCO_CUR [1:0]	VCO Dynamic Current 00 = Minimum value 01 = 10 = 11 = Maximum value (Recommended)

Programming Description (Continued)

R4 REGISTER

The R4 register address bits (R3 [3:0]) are "0111".

Register R4 is used to set the IF N counters if the default value is not desired. This register is only active if the SPI_DEF bit in register R0 is 0.

R4 REGISTER

Register	MSB	SHIFT REGISTER BIT LOCATION																LSB					
	23	22	21	20	19	18	17	16	15	14	13	12	11	10	9	8	7	6	5	4	3	2	1
	Data Field																Address Field						
R4	0	0	0	1	0	0	0	IF_A [3:0]				IF_B [8:0]					0	1	1	1			

Name	Functions
IF_A [3:0]	IF A Counter 4-bit swallow counter $0 \leq \text{IF_A} \leq 15$
IF_B [8:0]	IF B Counter 9-bit programmable counter $1 \leq \text{IF_B} \leq 511$

IF Frequency Setting:

$$f_{VCO} = \{16 \times \text{IF_B} + \text{IF_A}\} \times f_{OSC} / \text{IF_R} \text{ where } (\text{IF_A} < \text{IF_B})$$

where

f_{VCO} : Output frequency of IF voltage controlled oscillator (IF VCO)

IF_B: Preset divide ratio of binary 9-bit programmable counter ($1 \leq \text{IF_B} \leq 511$)

IF_A: Preset divide ratio of binary 4-bit swallow counter ($0 \leq \text{IF_A} \leq 15$)

IF_R: Preset divide ratio of binary 9-bit programmable reference counter ($2 \leq \text{IF_R} \leq 511$)

f_{OSC} : Reference oscillator frequency

Programming Description (Continued)

R5 REGISTER

The R5 register address bits (R5 [4:0]) are "01111".

Register R5 is used to set the IF_R divider if the default value is not desired. This register is only active if the SPI_DEF bit in register R0 is 0.

R5 REGISTER

Register	MSB	SHIFT REGISTER BIT LOCATION																LSB								
	23	22	21	20	19	18	17	16	15	14	13	12	11	10	9	8	7	6	5	4	3	2	1	0		
	Data Field																Address Field									
R5	0	0	1	1	0	0	0	0	1	0	IF_R [8:0]					0	1	1	1	1						

Name	Functions
IF_R [8:0]	IF R Counter 9-bit programmable counter $2 \leq \text{IF_R} \leq 511$

R6 REGISTER

The R6 register address bits (R6 [5:0]) are "011111".

Register R6 is used for internal testing of the device and is not intended for customer use. This register is only active if the SPI_DEF bit in register R0 is 0.

R6 REGISTER

Register	MSB	SHIFT REGISTER BIT LOCATION																LSB							
	23	22	21	20	19	18	17	16	15	14	13	12	11	10	9	8	7	6	5	4	3	2	1	0	
	Data Field																Address Field								
R6	1	0	0	0	0	0	0	0	0	0	0	0	0	0	0	0	0	0	0	0	1	1	1	1	1

Physical Dimensions inches (millimeters) unless otherwise noted

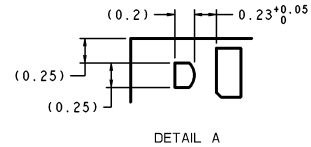
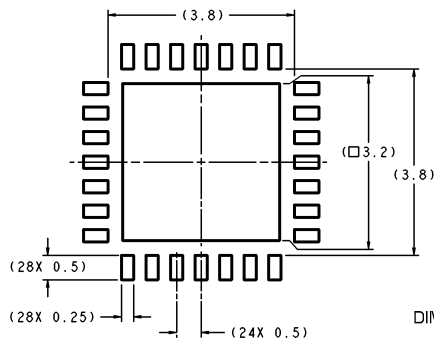

DIMENSIONS ARE IN MILLIMETERS

RECOMMENDED LAND PATTERN
1:1 RATION WITH PKG SOLDER PADS

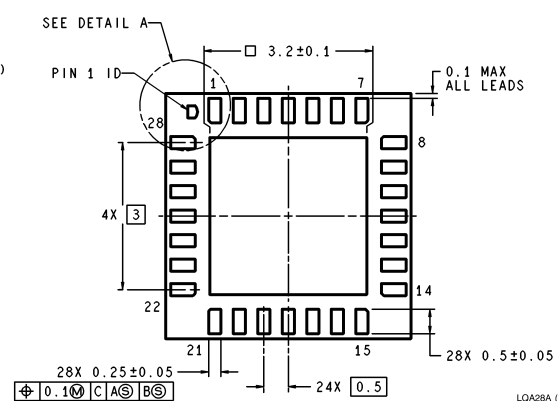
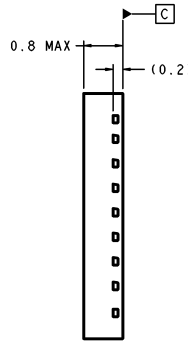
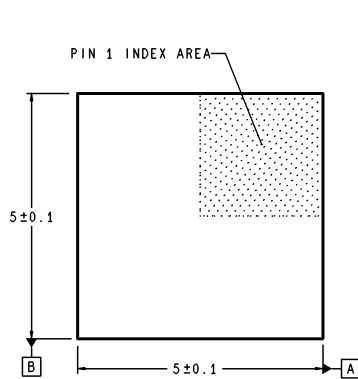

LQA28A (Rev B)

**Leadless Leadframe Package (LLP)
NS Package Number LQA28A**

LIFE SUPPORT POLICY

NATIONAL'S PRODUCTS ARE NOT AUTHORIZED FOR USE AS CRITICAL COMPONENTS IN LIFE SUPPORT DEVICES OR SYSTEMS WITHOUT THE EXPRESS WRITTEN APPROVAL OF THE PRESIDENT AND GENERAL COUNSEL OF NATIONAL SEMICONDUCTOR CORPORATION. As used herein:

1. Life support devices or systems are devices or systems which, (a) are intended for surgical implant into the body, or (b) support or sustain life, and whose failure to perform when properly used in accordance with instructions for use provided in the labeling, can be reasonably expected to result in a significant injury to the user.
2. A critical component is any component of a life support device or system whose failure to perform can be reasonably expected to cause the failure of the life support device or system, or to affect its safety or effectiveness.



**National Semiconductor
Americas Customer
Support Center**
Email: new.feedback@nsc.com
Tel: 1-800-272-9959

**National Semiconductor
Europe Customer Support Center**
Fax: +49 (0) 180-530 85 86
Email: europe.support@nsc.com
Deutsch Tel: +49 (0) 69 9508 6208
English Tel: +44 (0) 870 24 0 2171
Français Tel: +33 (0) 1 41 91 8790

**National Semiconductor
Asia Pacific Customer
Support Center**
Email: ap.support@nsc.com

**National Semiconductor
Japan Customer Support Center**
Fax: 81-3-5639-7507
Email: jpn.feedback@nsc.com
Tel: 81-3-5639-7560

www.national.com