

## LM118/LM218/LM318 Operational Amplifiers

### General Description

The LM118 series are precision high speed operational amplifiers designed for applications requiring wide bandwidth and high slew rate. They feature a factor of ten increase in speed over general purpose devices without sacrificing DC performance.

The LM118 series has internal unity gain frequency compensation. This considerably simplifies its application since no external components are necessary for operation. However, unlike most internally compensated amplifiers, external frequency compensation may be added for optimum performance. For inverting applications, feedforward compensation will boost the slew rate to over  $150\text{V}/\mu\text{s}$  and almost double the bandwidth. Overcompensation can be used with the amplifier for greater stability when maximum bandwidth is not needed. Further, a single capacitor can be added to reduce the 0.1% settling time to under  $1\ \mu\text{s}$ .

The high speed and fast settling time of these op amps make them useful in A/D converters, oscillators, active filters,

sample and hold circuits, or general purpose amplifiers. These devices are easy to apply and offer an order of magnitude better AC performance than industry standards such as the LM709.

The LM218 is identical to the LM118 except that the LM218 has its performance specified over a  $-25^{\circ}\text{C}$  to  $+85^{\circ}\text{C}$  temperature range. The LM318 is specified from  $0^{\circ}\text{C}$  to  $+70^{\circ}\text{C}$ .

### Features

- 15 MHz small signal bandwidth
- Guaranteed  $50\text{V}/\mu\text{s}$  slew rate
- Maximum bias current of 250 nA
- Operates from supplies of  $\pm 5\text{V}$  to  $\pm 20\text{V}$
- Internal frequency compensation
- Input and output overload protected
- Pin compatible with general purpose op amps

### Fast Voltage Follower

(Note 1)

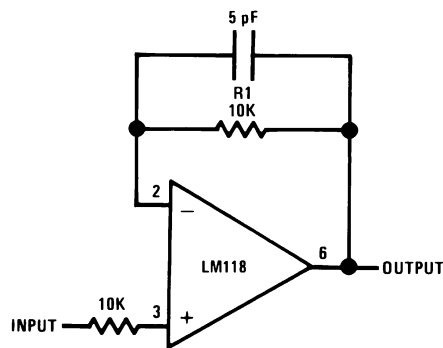

DS007766-13

**Note 1:** Do not hard-wire as voltage follower ( $R1 \geq 5\ \text{k}\Omega$ )

**Absolute Maximum Ratings** (Note 7)

If Military/Aerospace specified devices are required, please contact the National Semiconductor Sales Office/Distributors for availability and specifications.

Supply Voltage	±20V
Power Dissipation (Note 2)	500 mW
Differential Input Current (Note 3)	±10 mA
Input Voltage (Note 4)	±15V
Output Short-Circuit Duration	Continuous
Operating Temperature Range	
LM118	-55°C to +125°C
LM218	-25°C to +85°C
LM318	0°C to +70°C
Storage Temperature Range	-65°C to +150°C

Lead Temperature (Soldering, 10 sec.)

Hermetic Package	300°C
Plastic Package	260°C

Soldering Information

Dual-In-Line Package	
Soldering (10 sec.)	260°C
Small Outline Package	
Vapor Phase (60 sec.)	215°C
Infrared (15 sec.)	220°C

See AN-450 "Surface Mounting Methods and Their Effect on Product Reliability" for other methods of soldering surface mount devices.

ESD Tolerance (Note 8)	2000V
------------------------	-------

**Electrical Characteristics** (Note 5)

Parameter	Conditions	LM118/LM218			LM318			Units
		Min	Typ	Max	Min	Typ	Max	
Input Offset Voltage	$T_A = 25^\circ\text{C}$		2	4		4	10	mV
Input Offset Current	$T_A = 25^\circ\text{C}$		6	50		30	200	nA
Input Bias Current	$T_A = 25^\circ\text{C}$		120	250		150	500	nA
Input Resistance	$T_A = 25^\circ\text{C}$	1	3		0.5	3		MΩ
Supply Current	$T_A = 25^\circ\text{C}$		5	8		5	10	mA
Large Signal Voltage Gain	$T_A = 25^\circ\text{C}$ , $V_S = \pm 15\text{V}$ $V_{OUT} = \pm 10\text{V}$ , $R_L \geq 2\text{ k}\Omega$	50	200		25	200		V/mV
Slew Rate	$T_A = 25^\circ\text{C}$ , $V_S = \pm 15\text{V}$ , $A_V = 1$ (Note 6)	50	70		50	70		V/μs
Small Signal Bandwidth	$T_A = 25^\circ\text{C}$ , $V_S = \pm 15\text{V}$		15			15		MHz
Input Offset Voltage				6			15	mV
Input Offset Current				100			300	nA
Input Bias Current				500			750	nA
Supply Current	$T_A = 125^\circ\text{C}$		4.5	7				mA
Large Signal Voltage Gain	$V_S = \pm 15\text{V}$ , $V_{OUT} = \pm 10\text{V}$ $R_L \geq 2\text{ k}\Omega$	25			20			V/mV
Output Voltage Swing	$V_S = \pm 15\text{V}$ , $R_L = 2\text{ k}\Omega$	±12	±13		±12	±13		V
Input Voltage Range	$V_S = \pm 15\text{V}$	±11.5			±11.5			V
Common-Mode Rejection Ratio		80	100		70	100		dB
Supply Voltage Rejection Ratio		70	80		65	80		dB

**Note 2:** The maximum junction temperature of the LM118 is 150°C, the LM218 is 110°C, and the LM318 is 110°C. For operating at elevated temperatures, devices in the H08 package must be derated based on a thermal resistance of 160°C/W, junction to ambient, or 20°C/W, junction to case. The thermal resistance of the dual-in-line package is 100°C/W, junction to ambient.

**Note 3:** The inputs are shunted with back-to-back diodes for overvoltage protection. Therefore, excessive current will flow if a differential input voltage in excess of 1V is applied between the inputs unless some limiting resistance is used.

**Note 4:** For supply voltages less than ±15V, the absolute maximum input voltage is equal to the supply voltage.

**Note 5:** These specifications apply for  $\pm 5\text{V} \leq V_S \leq \pm 20\text{V}$  and  $-55^\circ\text{C} \leq T_A \leq +125^\circ\text{C}$  (LM118),  $-25^\circ\text{C} \leq T_A \leq +85^\circ\text{C}$  (LM218), and  $0^\circ\text{C} \leq T_A \leq +70^\circ\text{C}$  (LM318). Also, power supplies must be bypassed with 0.1 μF disc capacitors.

**Note 6:** Slew rate is tested with  $V_S = \pm 15\text{V}$ . The LM118 is in a unity-gain non-inverting configuration.  $V_{IN}$  is stepped from -7.5V to +7.5V and vice versa. The slew rates between -5.0V and +5.0V and vice versa are tested and guaranteed to exceed 50V/μs.

**Note 7:** Refer to RETS118X for LM118H and LM118J military specifications.

**Note 8:** Human body model, 1.5 kΩ in series with 100 pF.

# Typical Performance Characteristics LM118, LM218

## Input Current

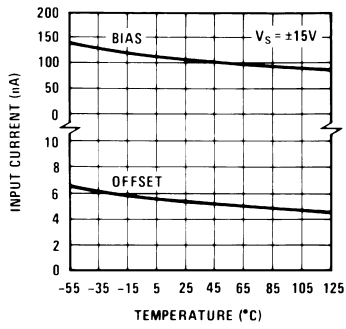

## Voltage Gain

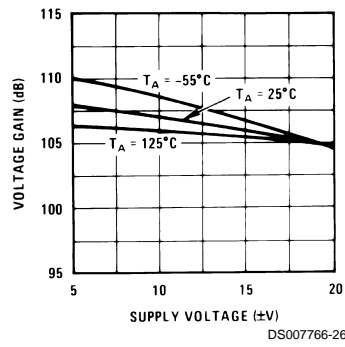

## Power Supply Rejection

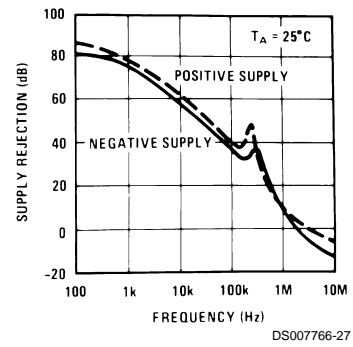

## Input Noise Voltage

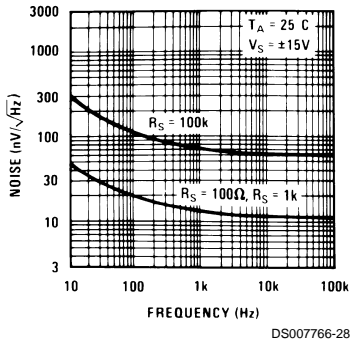

## Common Mode Rejection

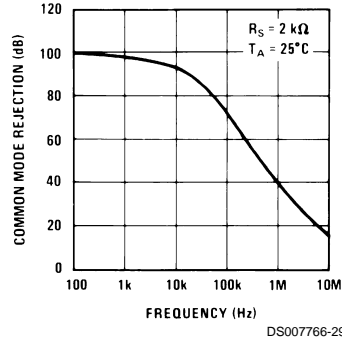

## Supply Current

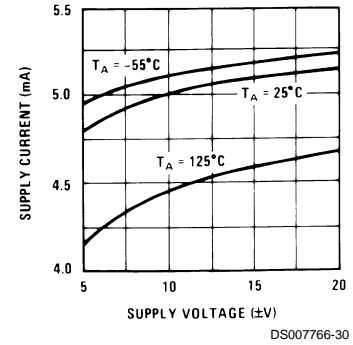

## Closed Loop Output Impedance

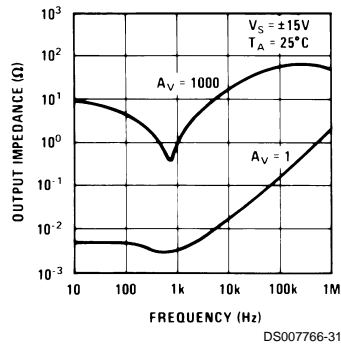

## Current Limiting

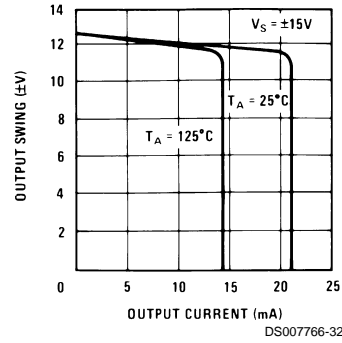

## Input Current

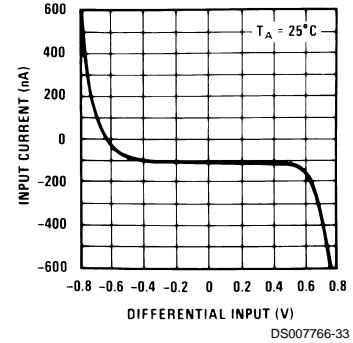

## Unity Gain Bandwidth

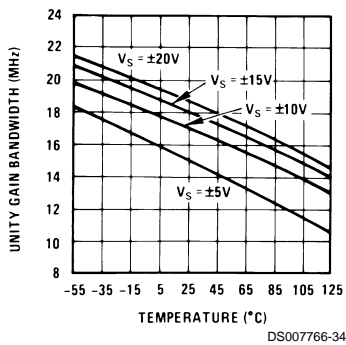

## Voltage Follower Slew Rate

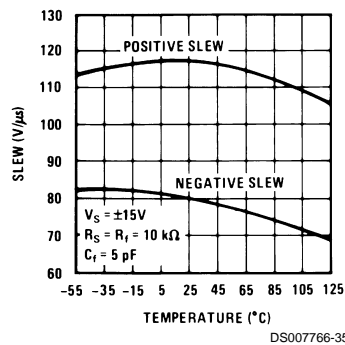

## Inverter Settling Time

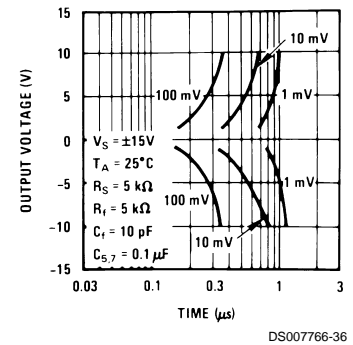

## Typical Performance Characteristics LM118, LM218 (Continued)

Large Signal Frequency Response

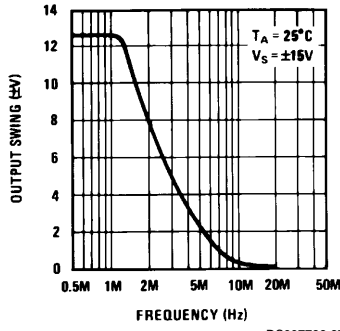

Open Loop Frequency Response

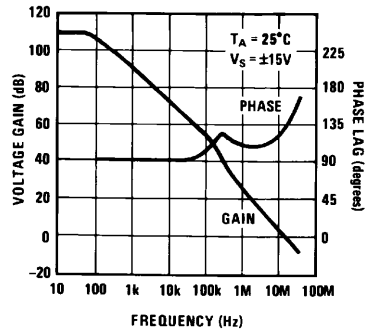

Voltage Follower Pulse Response

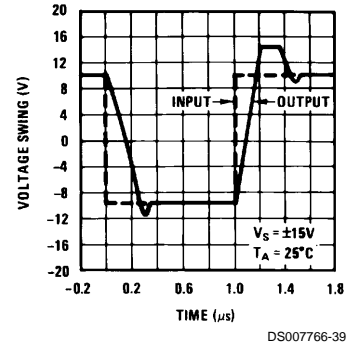

Large Signal Frequency Response

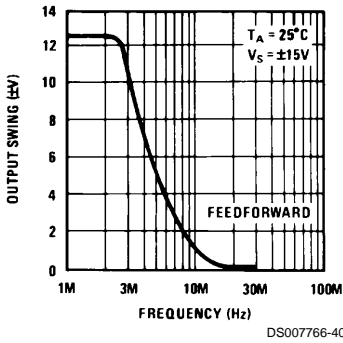

Open Loop Frequency Response

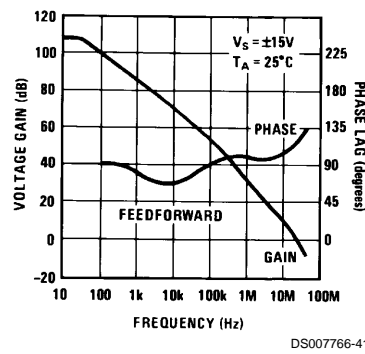

Inverter Pulse Response

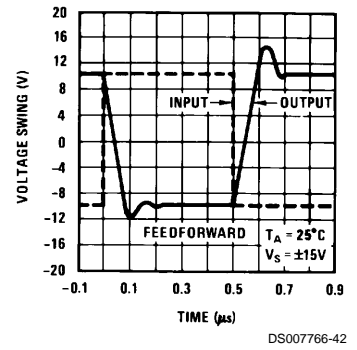

## Typical Performance Characteristics LM318

Input Current

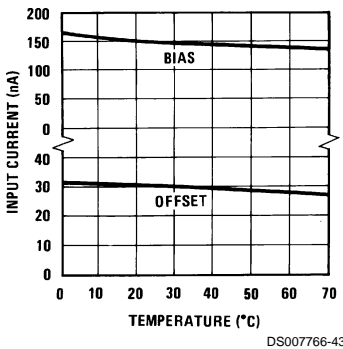

Voltage Gain

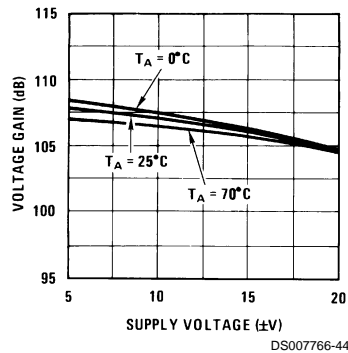

Power Supply Rejection

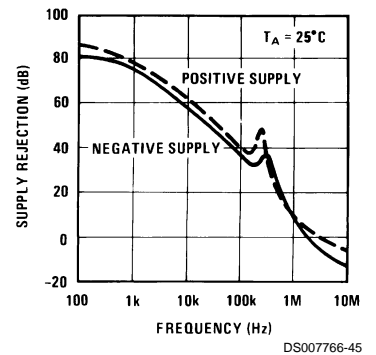

# Typical Performance Characteristics LM318 (Continued)

**Input Noise Voltage**

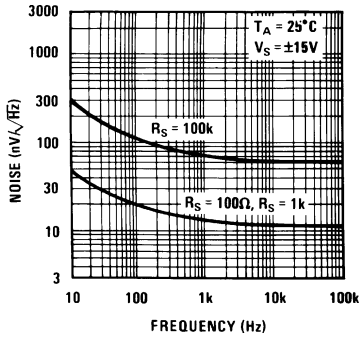

**Common Mode Rejection**

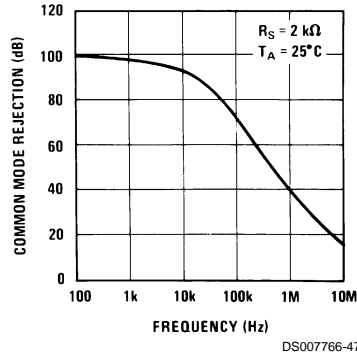

**Supply Current**

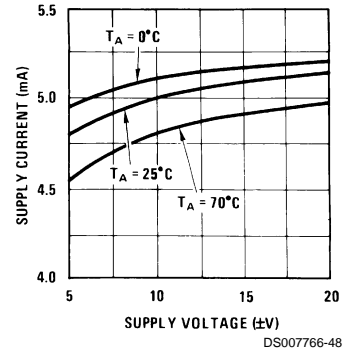

**Closed Loop Output Impedance**

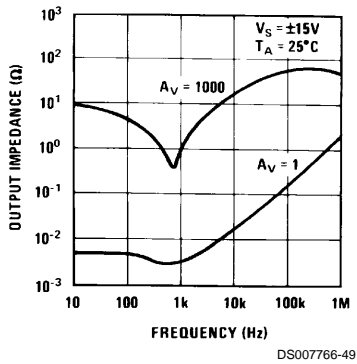

**Current Limiting**

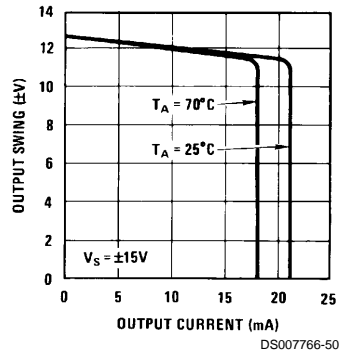

**Input Current**

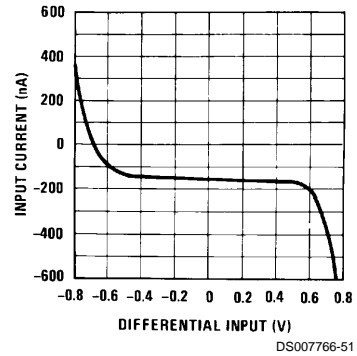

**Unity Gain Bandwidth**

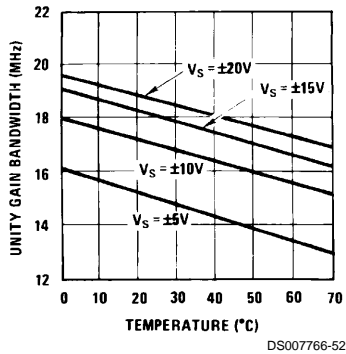

**Voltage Follower Slew Rate**

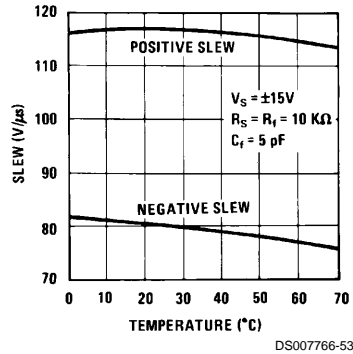

**Inverter Settling Time**

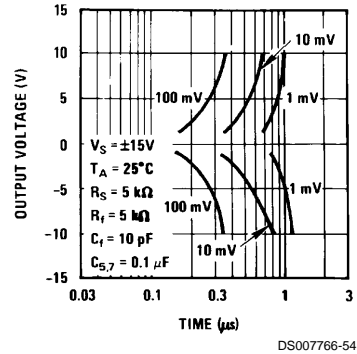

# Typical Performance Characteristics LM318 (Continued)

**Large Signal Frequency Response**

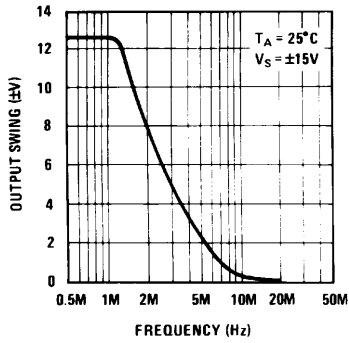

DS007766-55

**Open Loop Frequency Response**

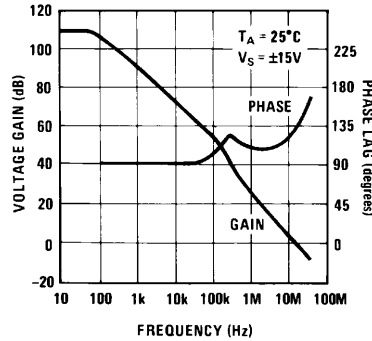

DS007766-56

**Voltage Follower Pulse Response**

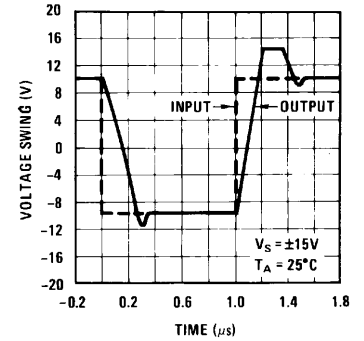

DS007766-57

**Large Signal Frequency Response**

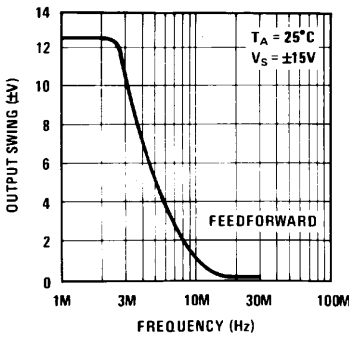

DS007766-58

**Open Loop Frequency Response**

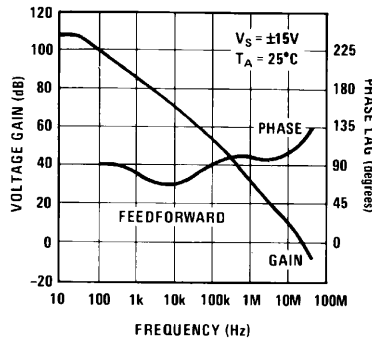

DS007766-59

**Inverter Pulse Response**

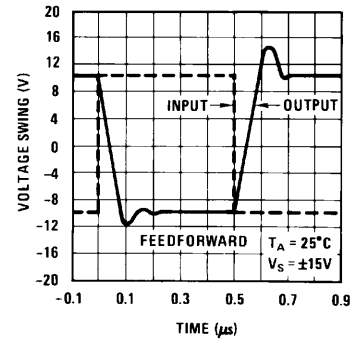

DS007766-60

## Auxiliary Circuits

**Feedforward Compensation for Greater Inverting Slew Rate (Note 9)**

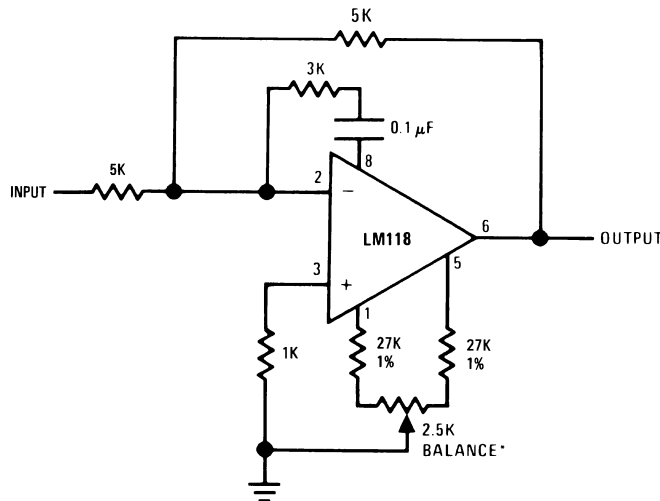

DS007766-8

**Compensation for Minimum Settling Time (Note 10)**

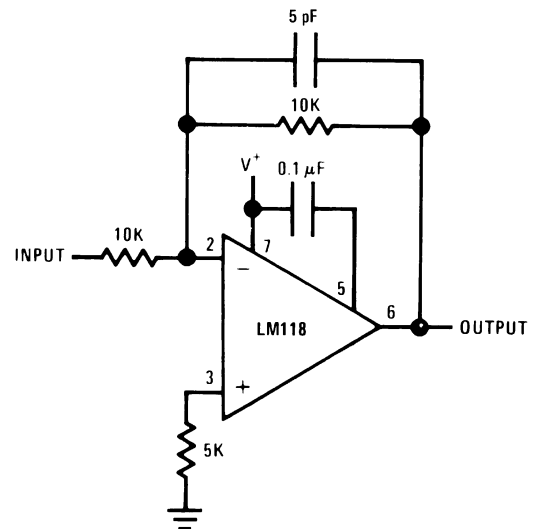

DS007766-9

\*Balance circuit necessary for increased slew.

**Note 9:** Slew rate typically 150V/µs.

**Note 10:** Slew and settling time to 0.1% for a 10V step change is 800 ns.

## Auxiliary Circuits (Continued)

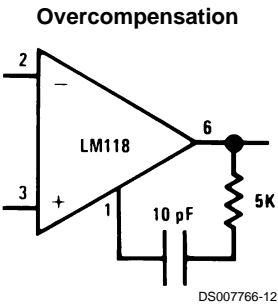
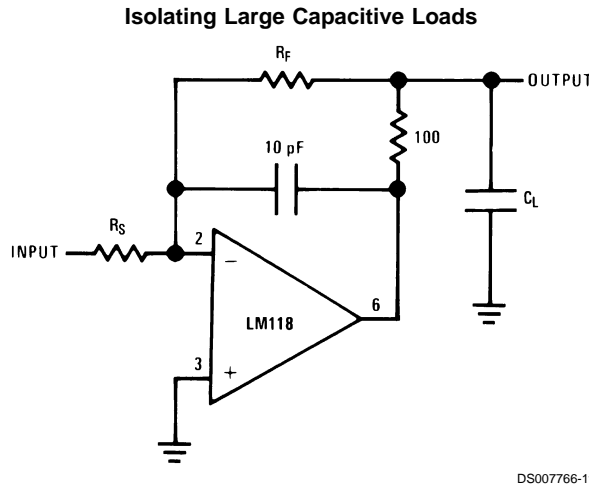
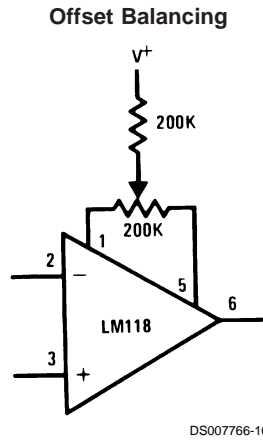

## Typical Applications

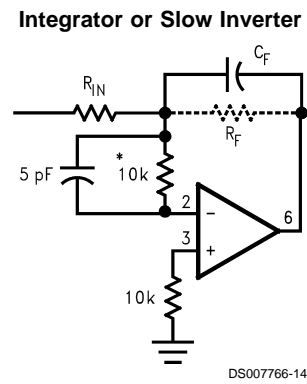
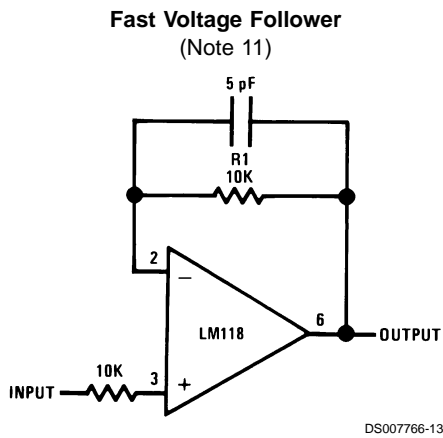

$C_F = \text{Large}$   
( $C_F \geq 50 \text{ pF}$ )

\*Do not hard-wire as integrator or slow inverter; insert a 10k-5 pF network in series with the input, to prevent oscillation.

**Note 11:** Do not hard-wire as voltage follower ( $R_1 \geq 5 \text{ k}\Omega$ )

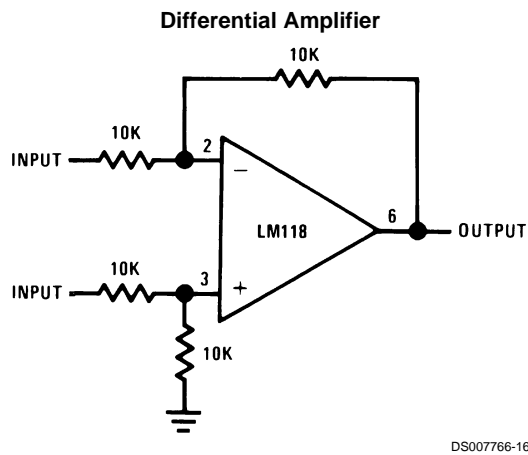
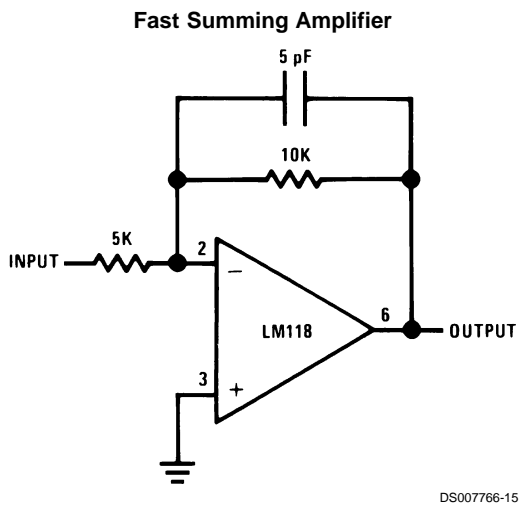

Typical Applications (Continued)

Fast Sample and Hold

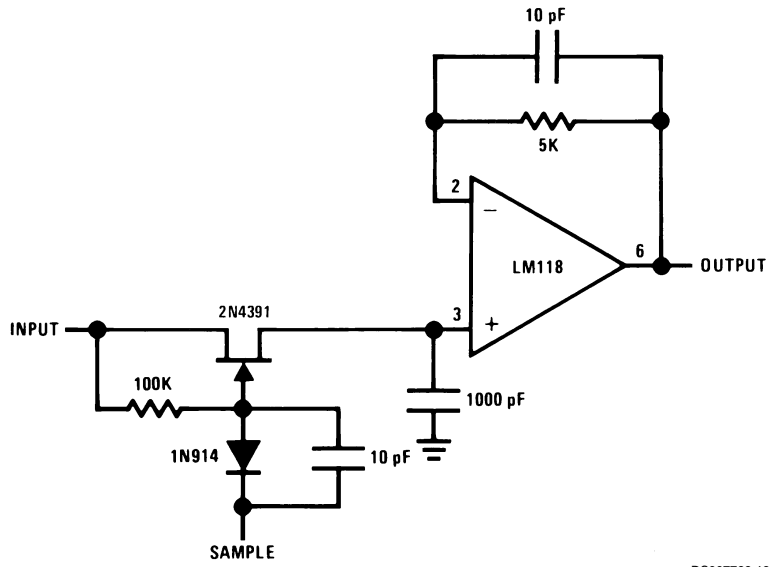

DS007766-18

D/A Converter Using Ladder Network

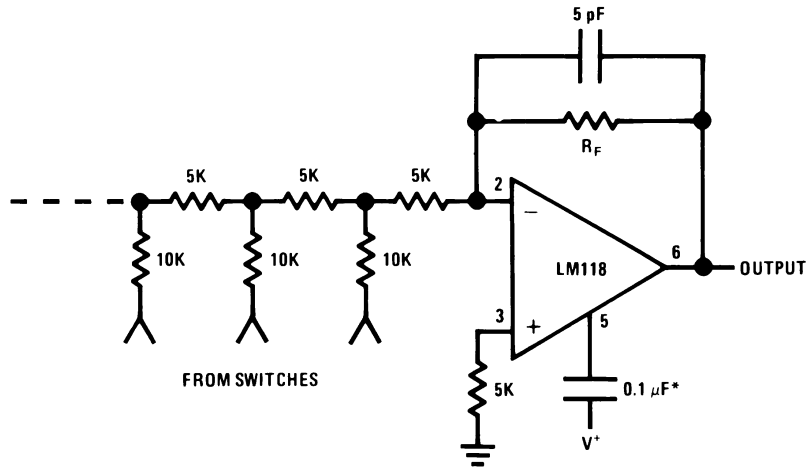

DS007766-19

\*Optional — Reduces settling time.



# Typical Applications (Continued)

Four Quadrant Multiplier

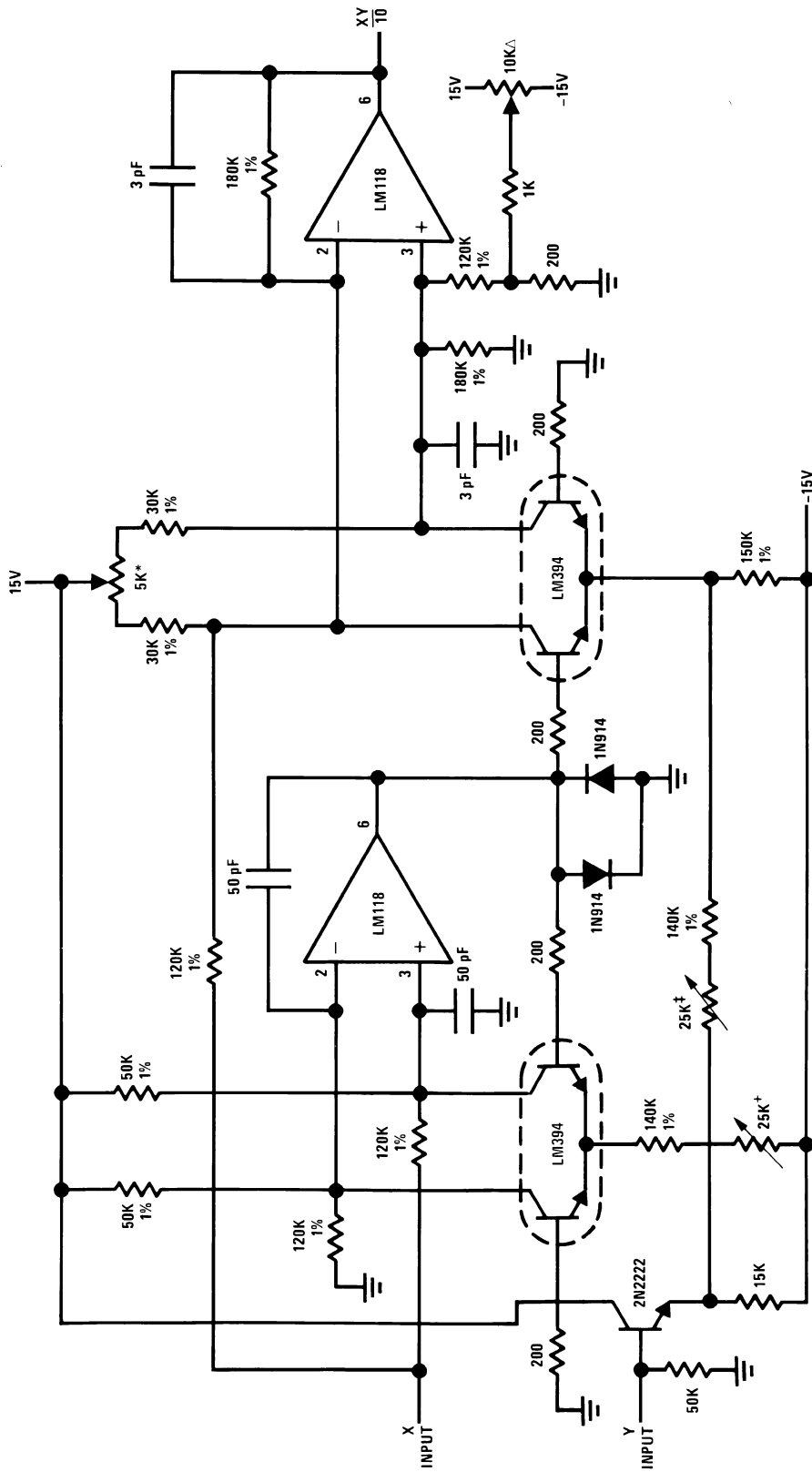

DS00766-17

Δ Output zero.  
 \* "Y" zero  
 + "X" zero  
 ‡ Full scale adjust.

## Typical Applications (Continued)

### D/A Converter Using Binary Weighted Network

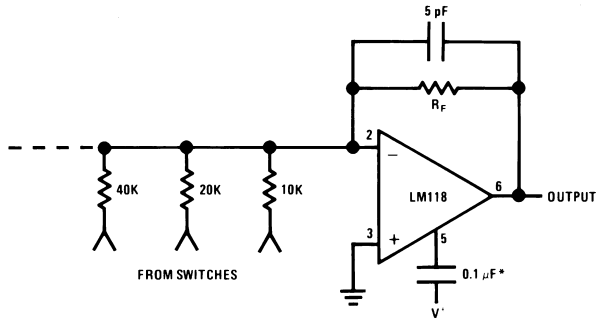

DS007766-20

\*Optional — Reduces settling time.

### Fast Summing Amplifier with Low Input Current

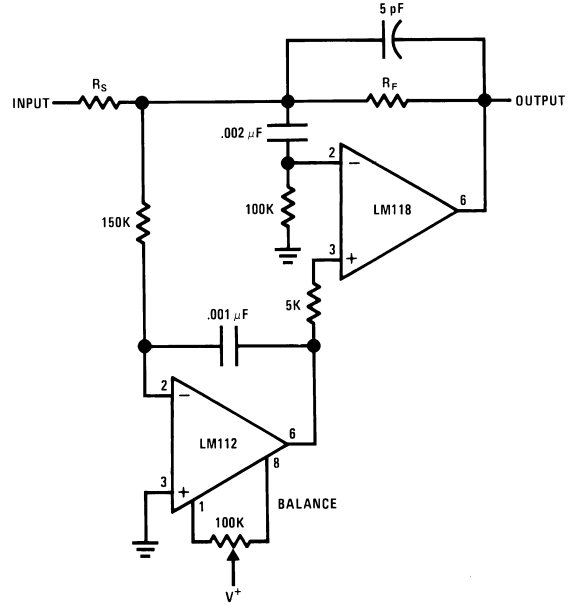

DS007766-21

### Wein Bridge Sine Wave Oscillator

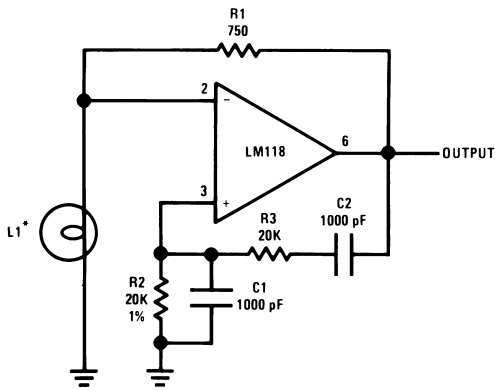

DS007766-22

\*L1—10V—14 mA bulb ELDEMA 1869

R1 = R2

C1 = C2

$$f = \frac{1}{2\pi R_2 C_1}$$

### Instrumentation Amplifier

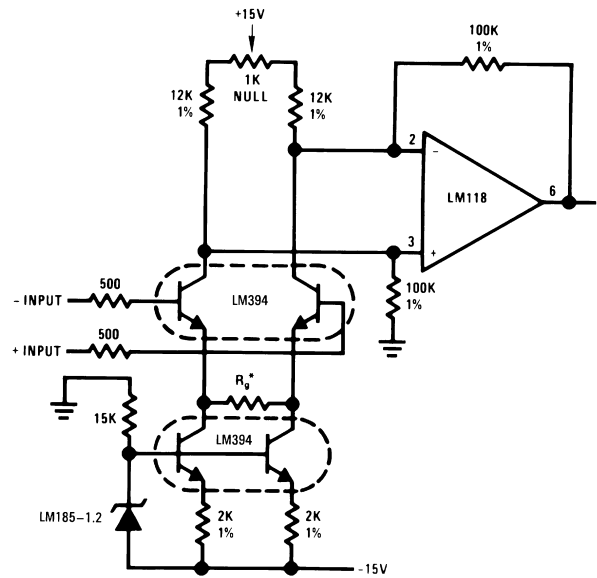

DS007766-23

$$*Gain \geq \frac{200K}{R_g} \text{ for } 1.5K \leq R_g \leq 200K$$

# Schematic Diagram

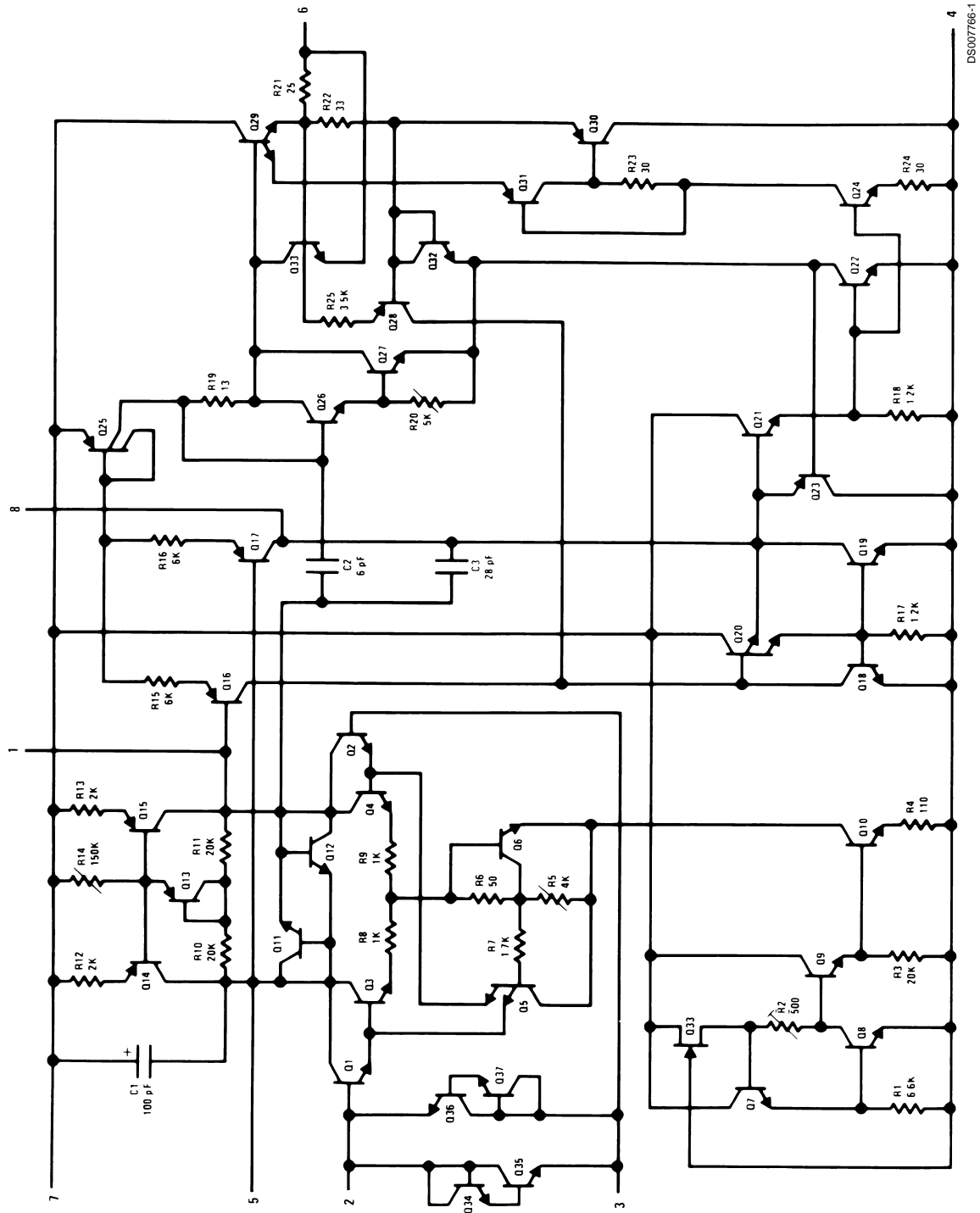

LM118/LM218/LM318

## Connection Diagram

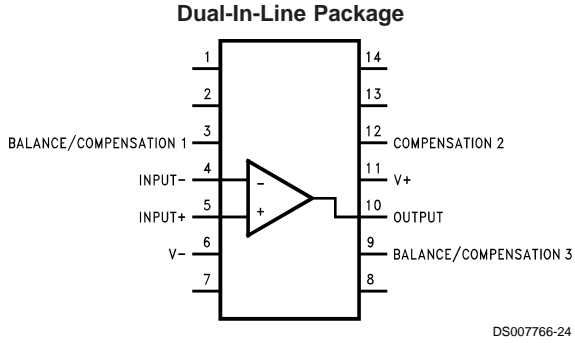

**Top View**  
**Order Number LM118J/883 (Note 13)**  
**See NS Package Number J14A**

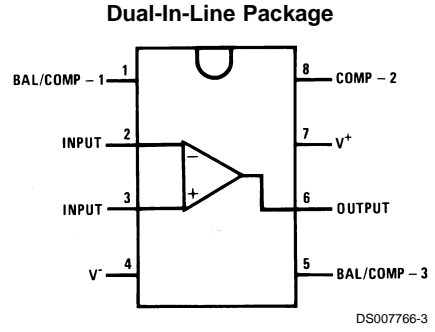

**Top View**  
**Order Number LM118J-8/883 (Note 13),**  
**LM318M or LM318N**  
**See NS Package Number J08A, M08A or N08B**

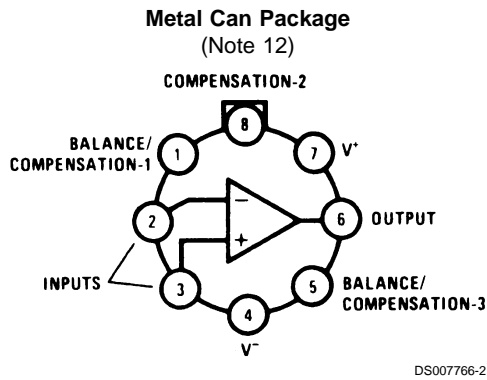

**Top View**  
**Order Number LM118H, LM118H/883 (Note 13),**  
**LM218H or LM318H**  
**See NS Package Number H08C**

**Note 12:** Pin connections shown on schematic diagram and typical applications are for TO-5 package.

**Note 13:** Available per JM38510/10107.



**Physical Dimensions** inches (millimeters) unless otherwise noted (Continued)

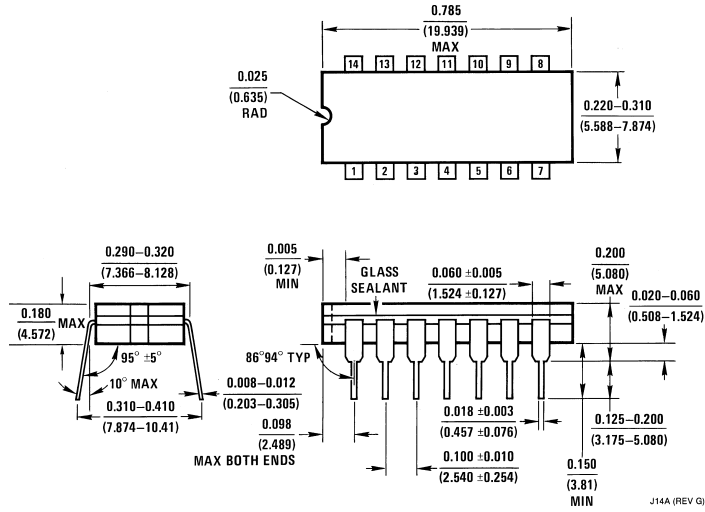

**Ceramic Dual-In-Line Package (J)**  
**Order Number LM118J/883**  
**NS Package Number J14A**

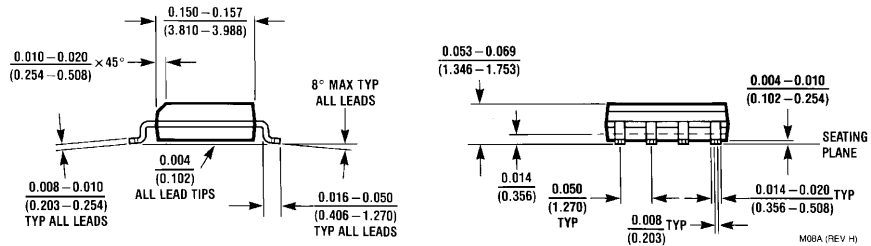
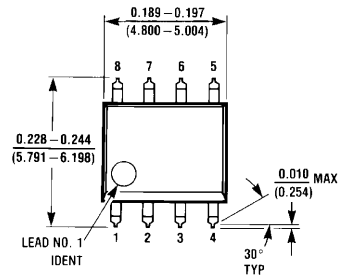

**S.O. Package (M)**  
**Order Number LM318M or LM318MX**  
**NS Package Number M08A**

**Physical Dimensions** inches (millimeters) unless otherwise noted (Continued)

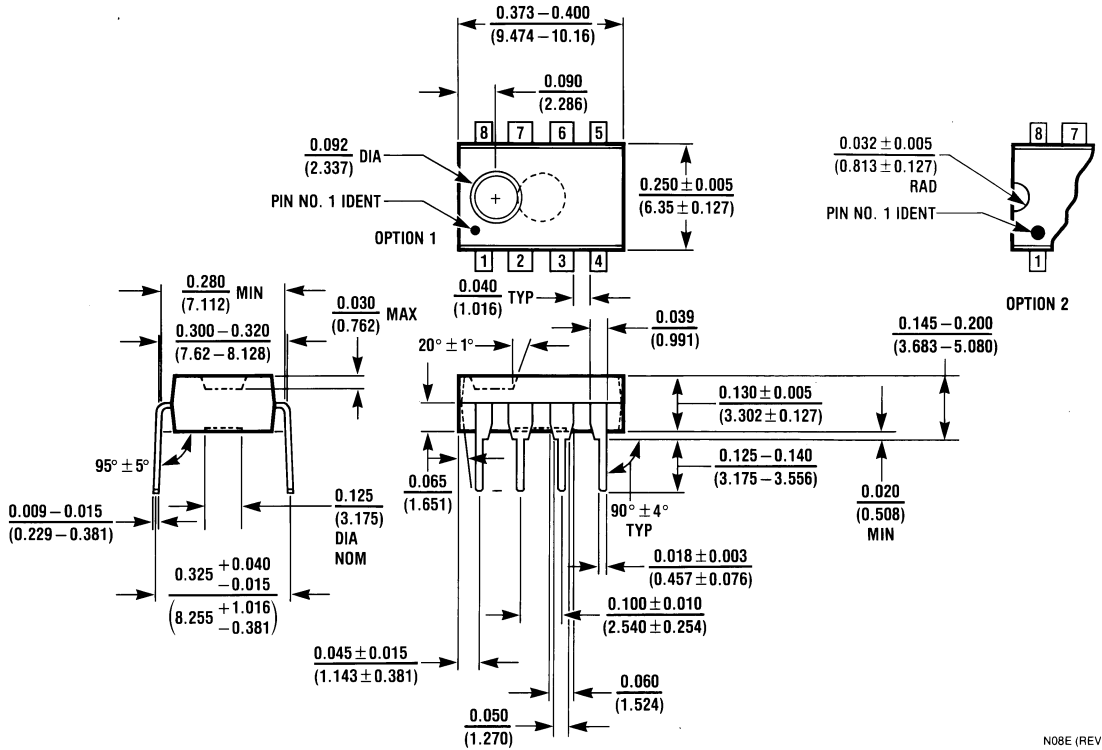

**Molded Dual-In-Line Package (N)**  
**Order Number LM318N**  
**NS Package Number N08E**

N08E (REV F)

**LIFE SUPPORT POLICY**

NATIONAL'S PRODUCTS ARE NOT AUTHORIZED FOR USE AS CRITICAL COMPONENTS IN LIFE SUPPORT DEVICES OR SYSTEMS WITHOUT THE EXPRESS WRITTEN APPROVAL OF THE PRESIDENT AND GENERAL COUNSEL OF NATIONAL SEMICONDUCTOR CORPORATION. As used herein:

1. Life support devices or systems are devices or systems which, (a) are intended for surgical implant into the body, or (b) support or sustain life, and whose failure to perform when properly used in accordance with instructions for use provided in the labeling, can be reasonably expected to result in a significant injury to the user.
2. A critical component is any component of a life support device or system whose failure to perform can be reasonably expected to cause the failure of the life support device or system, or to affect its safety or effectiveness.



**National Semiconductor Corporation**  
Americas  
Tel: 1-800-272-9959  
Fax: 1-800-737-7018  
Email: support@nsc.com  
www.national.com

**National Semiconductor Europe**  
Fax: +49 (0) 180-530 85 86  
Email: europe.support@nsc.com  
Deutsch Tel: +49 (0) 69 9508 6208  
English Tel: +44 (0) 870 24 0 2171  
Français Tel: +33 (0) 1 41 91 87 90

**National Semiconductor Asia Pacific Customer Response Group**  
Tel: 65-2544466  
Fax: 65-2504466  
Email: ap.support@nsc.com

**National Semiconductor Japan Ltd.**  
Tel: 81-3-5639-7560  
Email: nsj.crc@jksmtp.nsc.com  
Fax: 81-3-5639-7507