

## 54LS244/DM74LS244 Octal TRI-STATE® Buffers/Line Drivers/Line Receivers

### General Description

These buffers/line drivers are designed to improve both the performance and PC board density of TRI-STATE buffers/drivers employed as memory-address drivers, clock drivers, and bus-oriented transmitters/receivers. Featuring 400 mV of hysteresis at each low current PNP data line input, they provide improved noise rejection and high fanout outputs and can be used to drive terminated lines down to 133Ω.

### Features

- TRI-STATE outputs drive bus lines directly
- PNP inputs reduce DC loading on bus lines
- Hysteresis at data inputs improves noise margins

- Typical  $I_{OL}$  (sink current)
  - 54LS 12 mA
  - 74LS 24 mA
- Typical  $I_{OH}$  (source current)
  - 54LS -12 mA
  - 74LS -15 mA
- Typical propagation delay times
  - Inverting 10.5 ns
  - Noninverting 12 ns
- Typical enable/disable time 18 ns
- Typical power dissipation (enabled)
  - Inverting 130 mW
  - Noninverting 135 mW

### Connection Diagram

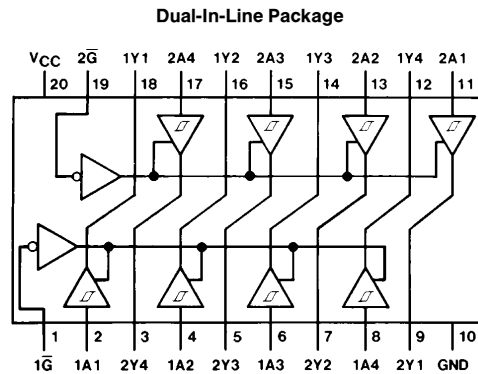

Order Number 54LS244DMQB, 54LS244FMQB, 54LS244LMQB,  
DM74LS244WM or DM74LS244N  
See NS Package Number E20A, J20A, M20B, N20A or W20A

### Function Table

Inputs		Output
$\bar{G}$	A	Y
L	L	L
L	H	H
H	X	Z

L = Low Logic Level  
H = High Logic Level  
X = Either Low or High Logic Level  
Z = High Impedance

TRI-STATE® is a registered trademark of National Semiconductor Corporation.

## Absolute Maximum Ratings (Note)

If Military/Aerospace specified devices are required, please contact the National Semiconductor Sales Office/Distributors for availability and specifications.

Supply Voltage	7V
Input Voltage	7V
Operating Free Air Temperature Range	
54LS	−55°C to +125°C
DM74LS	0°C to +70°C
Storage Temperature Range	−65°C to +150°C

Note: The "Absolute Maximum Ratings" are those values beyond which the safety of the device cannot be guaranteed. The device should not be operated at these limits. The parametric values defined in the "Electrical Characteristics" table are not guaranteed at the absolute maximum ratings. The "Recommended Operating Conditions" table will define the conditions for actual device operation.

## Recommended Operating Conditions

Symbol	Parameter	54LS244			DM74LS244			Units
		Min	Nom	Max	Min	Nom	Max	
V <sub>CC</sub>	Supply Voltage	4.5	5	5.5	4.75	5	5.25	V
V <sub>IH</sub>	High Level Input Voltage	2			2			V
V <sub>IL</sub>	Low Level Input Voltage			0.7			0.8	V
I <sub>OH</sub>	High Level Output Current			−12			−15	mA
I <sub>OL</sub>	Low Level Output Current			12			24	mA
T <sub>A</sub>	Free Air Operating Temperature	−55		125	0		70	°C

## Electrical Characteristics over recommended operating free air temperature range (unless otherwise noted)

Symbol	Parameter	Conditions	Min	Typ (Note 1)	Max	Units	
V <sub>I</sub>	Input Clamp Voltage	V <sub>CC</sub> = Min, I <sub>I</sub> = −18 mA			−1.5	V	
HYS	Hysteresis (V <sub>T+</sub> − V <sub>T−</sub> ) Data Inputs Only	V <sub>CC</sub> = Min	0.2	0.4		V	
V <sub>OH</sub>	High Level Output Voltage	V <sub>CC</sub> = Min, V <sub>IH</sub> = Min V <sub>IL</sub> = Max, I <sub>OH</sub> = −1 mA	DM74	2.7		V	
		V <sub>CC</sub> = Min, V <sub>IH</sub> = Min V <sub>IL</sub> = Max, I <sub>OH</sub> = −3 mA	54LS/DM74	2.4	3.4		
		V <sub>CC</sub> = Min, V <sub>IH</sub> = Min V <sub>IL</sub> = 0.5V, I <sub>OH</sub> = Max	54LS/DM74	2			
V <sub>OL</sub>	Low Level Output Voltage	V <sub>CC</sub> = Min V <sub>IL</sub> = Max V <sub>IH</sub> = Min	I <sub>OL</sub> = 12 mA	54LS/DM74		0.4	V
			I <sub>OL</sub> = Max	DM74		0.5	
I <sub>OZH</sub>	Off-State Output Current, High Level Voltage Applied	V <sub>CC</sub> = Max V <sub>IL</sub> = Max V <sub>IH</sub> = Min	V <sub>O</sub> = 2.7V			20	μA
I <sub>OZL</sub>	Off-State Output Current, Low Level Voltage Applied		V <sub>O</sub> = 0.4V			−20	μA
I <sub>I</sub>	Input Current at Maximum Input Voltage	V <sub>CC</sub> = Max	V <sub>I</sub> = 7V (DM74) V <sub>I</sub> = 10V (54LS)			0.1	mA
I <sub>IH</sub>	High Level Input Current	V <sub>CC</sub> = Max	V <sub>I</sub> = 2.7V			20	μA
I <sub>IL</sub>	Low Level Input Current	V <sub>CC</sub> = Max	V <sub>I</sub> = 0.4V		−0.5	−200	μA
I <sub>OS</sub>	Short Circuit Output Current	V <sub>CC</sub> = Max (Note 2)	54LS	−50	−225	mA	
			DM74	−40			
I <sub>CC</sub>	Supply Current	V <sub>CC</sub> = Max, Outputs Open	Outputs High		13	23	mA
			Outputs Low		27	46	
			Outputs Disabled		32	54	

Note 1: All typicals are at V<sub>CC</sub> = 5V, T<sub>A</sub> = 25°C.

Note 2: Not more than one output should be shorted at a time, and the duration should not exceed one second.

**Switching Characteristics** at  $V_{CC} = 5V$ ,  $T_A = 25^\circ C$  (see Section 1 for Test Waveforms and Output Load)

Symbol	Parameter	Conditions	54LS Max	DM74LS Max	Units
$t_{PLH}$	Propagation Delay Time Low to High Level Output	$C_L = 45 \text{ pF}$ $R_L = 667\Omega$	18	18	ns
$t_{PHL}$	Propagation Delay Time High to Low Level Output	$C_L = 45 \text{ pF}$ $R_L = 667\Omega$	18	18	ns
$t_{PZL}$	Output Enable Time to Low Level	$C_L = 45 \text{ pF}$ $R_L = 667\Omega$	30	30	ns
$t_{PZH}$	Output Enable Time to High Level	$C_L = 45 \text{ pF}$ $R_L = 667\Omega$	23	23	ns
$t_{PLZ}$	Output Disable Time from Low Level	$C_L = 5 \text{ pF}$ $R_L = 667\Omega$	25	25	ns
$t_{PHZ}$	Output Disable Time from High Level	$C_L = 5 \text{ pF}$ $R_L = 667\Omega$	18	18	ns
$t_{PLH}$	Propagation Delay Time Low to High Level Output	$C_L = 150 \text{ pF}$ $R_L = 667\Omega$		21	ns
$t_{PHL}$	Propagation Delay Time High to Low Level Output	$C_L = 150 \text{ pF}$ $R_L = 667\Omega$		22	ns
$t_{PZL}$	Output Enable Time to Low Level	$C_L = 150 \text{ pF}$ $R_L = 667\Omega$		33	ns
$t_{PZH}$	Output Enable Time to High Level	$C_L = 150 \text{ pF}$ $R_L = 667\Omega$		26	ns

**Note:** 54LS Output Load is  $C_L = 50 \text{ pF}$  for  $t_{PLH}$ ,  $t_{PHL}$ ,  $t_{PZL}$  and  $t_{PZH}$ .

**Physical Dimensions** inches (millimeters)

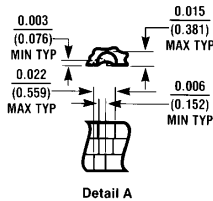
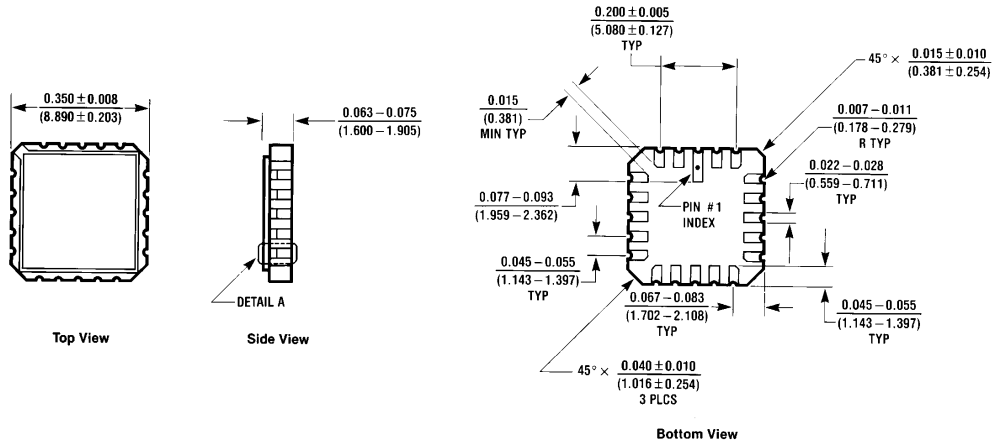

**Ceramic Leadless Chip Carrier Package (E)**  
**Order Number 54LS244LMQB**  
**NS Package Number E20A**

E20A (REV D)

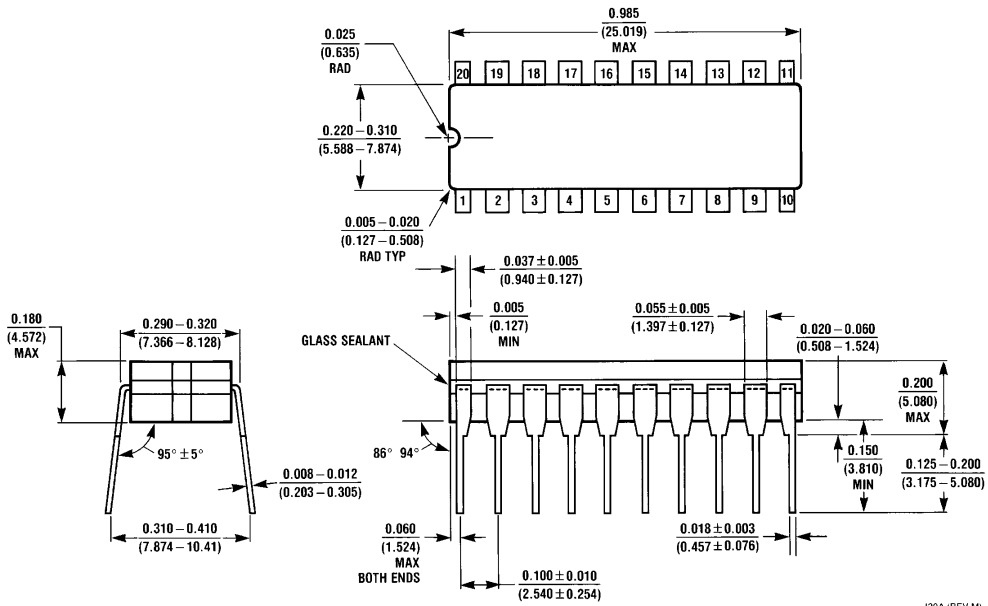

**20-Lead Ceramic Dual-In-Line Package (J)**  
**Order Number 54LS244DMQB**  
**NS Package Number J20A**

J20A (REV M)

**Physical Dimensions** inches (millimeters) (Continued)

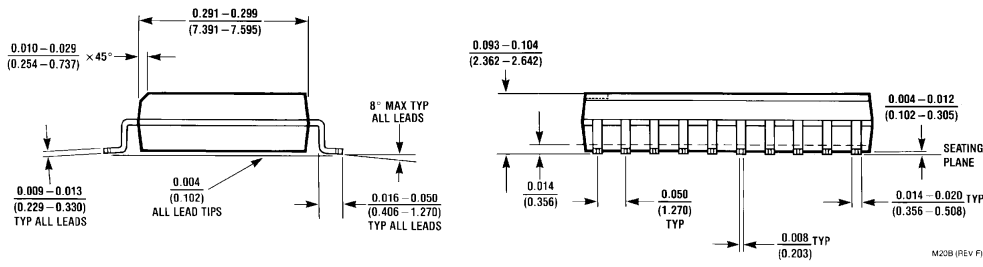
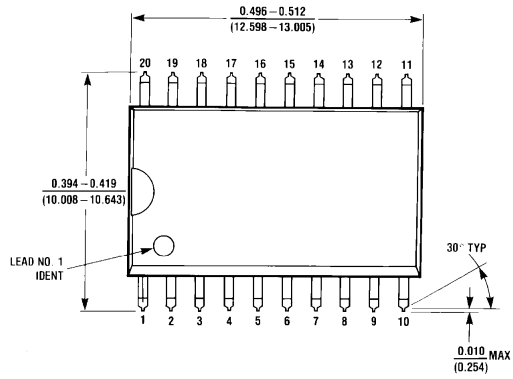

**20-Lead Wide Small Outline Molded Package (M)**  
**Order Number DM74LS244WM**  
**NS Package Number M20B**

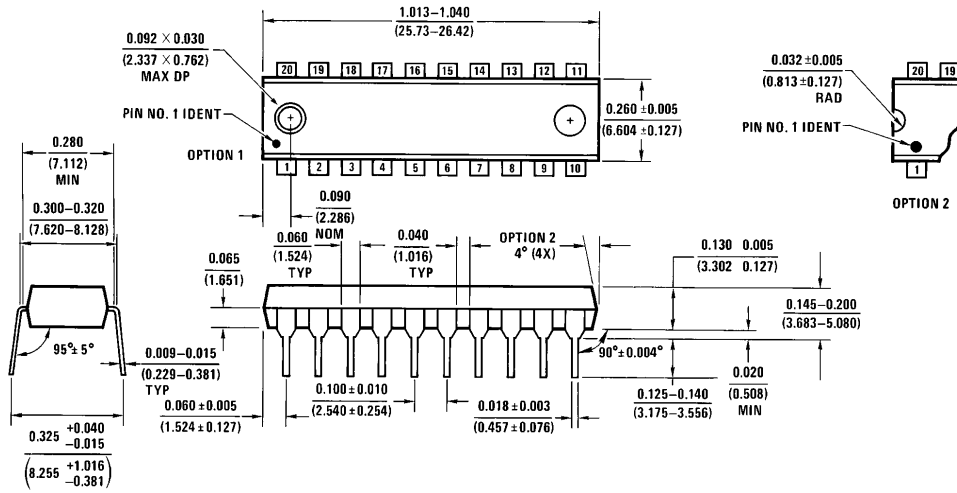

**20-Lead Molded Dual-In-Line Package (N)**  
**Order Number DM74LS244N**  
**NS Package Number N20A**

**Physical Dimensions** inches (millimeters) (Continued)

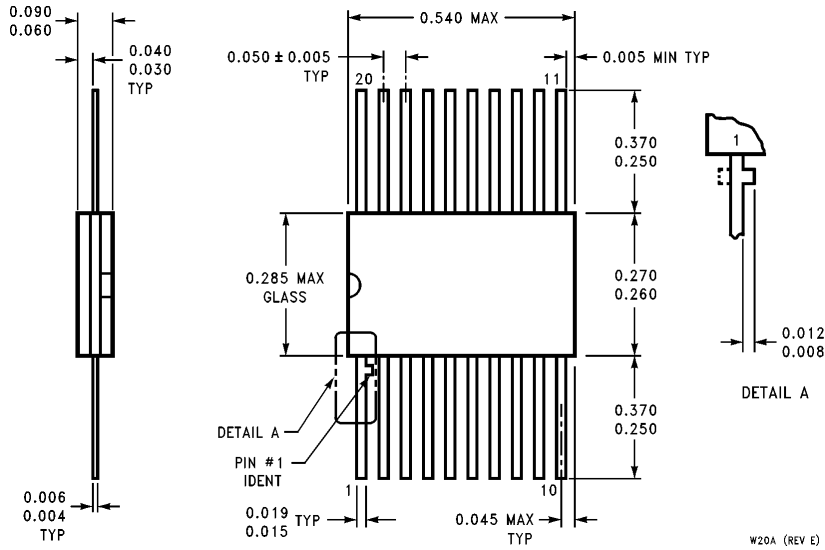

**20-Lead Ceramic Flat Package (W)**  
**Order Number 54LS244FMQB**  
**NS Package Number W20A**

**LIFE SUPPORT POLICY**

NATIONAL'S PRODUCTS ARE NOT AUTHORIZED FOR USE AS CRITICAL COMPONENTS IN LIFE SUPPORT DEVICES OR SYSTEMS WITHOUT THE EXPRESS WRITTEN APPROVAL OF THE PRESIDENT OF NATIONAL SEMICONDUCTOR CORPORATION. As used herein:

1. Life support devices or systems are devices or systems which, (a) are intended for surgical implant into the body, or (b) support or sustain life, and whose failure to perform, when properly used in accordance with instructions for use provided in the labeling, can be reasonably expected to result in a significant injury to the user.
2. A critical component is any component of a life support device or system whose failure to perform can be reasonably expected to cause the failure of the life support device or system, or to affect its safety or effectiveness.



**National Semiconductor Corporation**  
 1111 West Bardin Road  
 Arlington, TX 76017  
 Tel: 1(800) 272-9959  
 Fax: 1(800) 737-7018

**National Semiconductor Europe**  
 Fax: (+49) 0-180-530 85 86  
 Email: cnjwge@tevm2.nsc.com  
 Deutsch Tel: (+49) 0-180-530 85 85  
 English Tel: (+49) 0-180-532 78 32  
 Français Tel: (+49) 0-180-532 93 58  
 Italiano Tel: (+49) 0-180-534 16 80

**National Semiconductor Hong Kong Ltd.**  
 19th Floor, Straight Block,  
 Ocean Centre, 5 Canton Rd.  
 Tsimshatsui, Kowloon  
 Hong Kong  
 Tel: (852) 2737-1600  
 Fax: (852) 2736-9960

**National Semiconductor Japan Ltd.**  
 Tel: 81-043-299-2309  
 Fax: 81-043-299-2408

National does not assume any responsibility for use of any circuitry described, no circuit patent licenses are implied and National reserves the right at any time without notice to change said circuitry and specifications.