

54ACQ/74ACQ821 • 54ACTQ/74ACTQ821

Quiet Series 10-Bit D Flip-Flop with TRI-STATE® Outputs

General Description

The 'ACQ/'ACTQ821 is a 10-bit D flip-flop with non-inverting TRI-STATE outputs arranged in a broadside pinout. The 'ACQ/'ACTQ821 utilizes NSC Quiet Series technology to guarantee quiet output switching and improved dynamic threshold performance. FACT Quiet Series™ features GTO™ output control and undershoot corrector in addition to a split ground bus for superior performance.

The information for the ACQ821 is Advance information only.

Features

- Guaranteed simultaneous switching noise level and dynamic threshold performance
- Guaranteed pin-to-pin skew AC performance
- Non-inverting TRI-STATE outputs for bus interfacing
- 4 kV minimum ESD immunity
- Outputs source/sink 24 mA
- Functionally identical to the AM29821

Logic Symbols

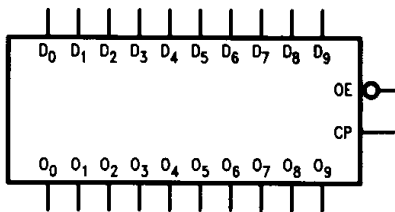

TL/F/10686-1

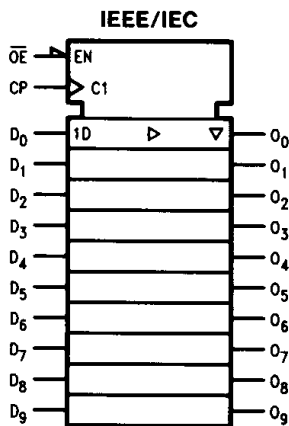

TL/F/10686-2

Pin Names	Description
D ₀ -D ₉	Data Inputs
O ₀ -O ₉	Data Outputs
OE	Output Enable Input
CP	Clock Input

Connection Diagrams

Pin Assignment for DIP, Flatpak and SOIC

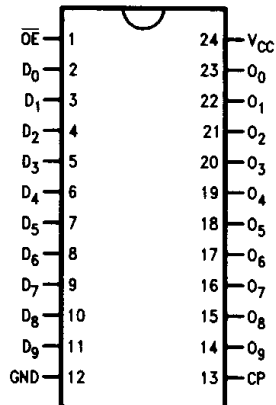

TL/F/10686-3

Pin Assignment for LCC

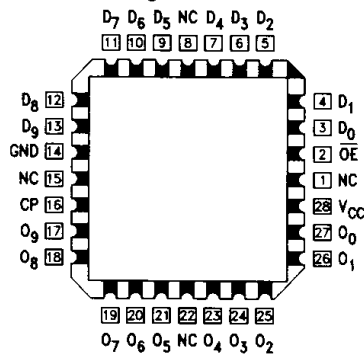

TL/F/10686-4

TRI-STATE® is a registered trademark of National Semiconductor Corporation.
FACT Quiet Series™ and GTO™ are trademarks of National Semiconductor Corporation.

Functional Description

The 'ACQ/'ACTQ821 consists of ten D-type edge-triggered flip-flops. The buffered Clock (CP) and buffered Output Enable (\overline{OE}) are common to all flip-flops. The flip-flops will store the state of their individual D inputs that meet the setup and hold time requirements on the LOW-to-HIGH CP transition. With \overline{OE} LOW the contents of the flip-flops are available at the outputs. When \overline{OE} is HIGH the outputs go to the high impedance state. Operation of the \overline{OE} input does not affect the state of the flip-flops.

The 'ACQ/'ACTQ821 is functionally and pin compatible with the AM29821.

Function Table

Inputs			Internal	Outputs	Function
\overline{OE}	CP	D	Q	O	
H	↗	L	L	Z	High Z
H	↗	H	H	Z	High Z
L	↗	L	L	L	Load
L	↗	H	H	H	Load

H = HIGH Voltage Level
 L = LOW Voltage Level
 Z = HIGH Impedance
 ↗ = LOW-to-HIGH Clock Transition

Logic Diagram

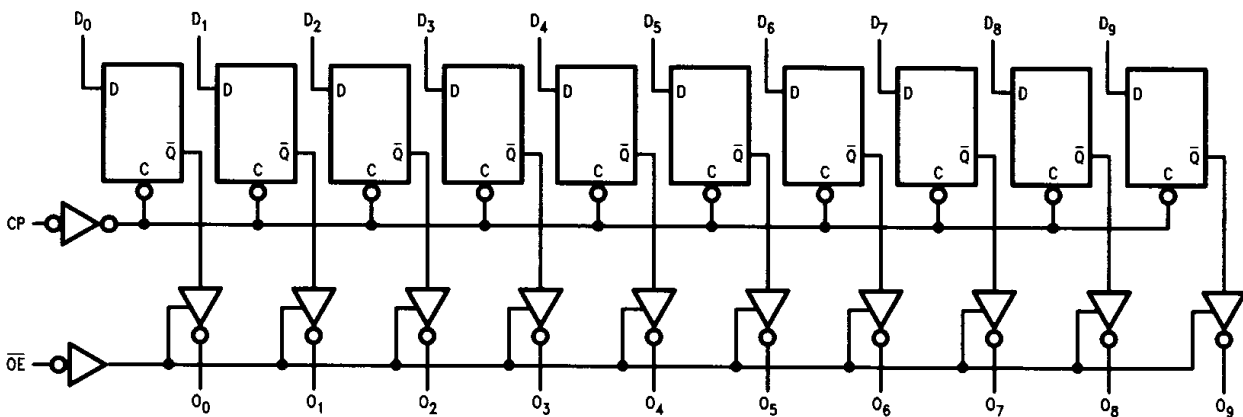

TL/F/10686-5

Please note that this diagram is provided only for the understanding of logic operations and should not be used to estimate propagation delays.

Absolute Maximum Rating (Note 1)

If Military/Aerospace specified devices are required, please contact the National Semiconductor Sales Office/Distributors for availability and specifications.

Supply Voltage (V_{CC})	-0.5V to +7.0V
DC Input Diode Current (I_{IK})	
$V_I = -0.5V$	-20 mA
$V_I = V_{CC} + 0.5V$	+20 mA
DC Input Voltage (V_I)	-0.5V to $V_{CC} + 0.5V$
DC Output Diode Current (I_{OK})	
$V_O = -0.5V$	-20 mA
$V_O = V_{CC} + 0.5V$	+20 mA
DC Output Voltage (V_O)	-0.5V to $V_{CC} + 0.5V$
DC Output Source or Sink Current (I_O)	± 50 mA
DC V_{CC} or Ground Current per Output Pin (I_{CC} or I_{GND})	± 50 mA
Storage Temperature (T_{STG})	-65°C to +150°C
DC Latch-Up Source or Sink Current	± 300 mA
Junction Temperature (T_J)	
CDIP	175°C
PDIP	140°C

Note 1: Absolute maximum ratings are those values beyond which damage to the device may occur. The databook specifications should be met, without exception, to ensure that the system design is reliable over its power supply, temperature, and output/input loading variables. National does not recommend operation of FACT™ circuits outside databook specifications.

Recommended Operating Conditions

Supply Voltage (V_{CC})	
'ACQ	2.0V to 6.0V
'ACTQ	4.5V to 5.5V
Input Voltage (V_I)	0V to V_{CC}
Output Voltage (V_O)	0V to V_{CC}
Operating Temperature (T_A)	
74ACQ/ACTQ	-40°C to +85°C
54ACQ/ACTQ	-55°C to +125°C
Minimum Input Edge Rate $\Delta V/\Delta t$	
'ACQ Devices	
V_{IN} from 30% to 70% of V_{CC}	
V_{CC} @ 3.0V, 4.5V, 5.5V	125 mV/ns
Minimum Input Edge Rate $\Delta V/\Delta t$	
'ACTQ Devices	
V_{IN} from 0.8V to 2.0V	
V_{CC} @ 4.5V, 5.5V	125 mV/ns

DC Electrical Characteristics for 'ACQ Family Devices

Symbol	Parameter	V_{CC} (V)	74ACQ		54ACQ	74ACQ	Units	Conditions	
			$T_A = +25^\circ\text{C}$		$T_A = -55^\circ\text{C to } +125^\circ\text{C}$	$T_A = -40^\circ\text{C to } +85^\circ\text{C}$			
			Typ	Guaranteed Limits					
V_{IH}	Minimum High Level Input Voltage	3.0	1.5	2.1	2.1	2.1	V	$V_{OUT} = 0.1V$ or $V_{CC} - 0.1V$	
		4.5	2.25	3.15	3.15	3.15			
		5.5	2.75	3.85	3.85	3.85			
V_{IL}	Maximum Low Level Input Voltage	3.0	1.5	0.9	0.9	0.9	V	$V_{OUT} = 0.1V$ or $V_{CC} - 0.1V$	
		4.5	2.25	1.35	1.35	1.35			
		5.5	2.75	1.65	1.65	1.65			
V_{OH}	Minimum High Level Output Voltage	3.0	2.99	2.9	2.9	2.9	V	$I_{OUT} = -50 \mu\text{A}$	
		4.5	4.49	4.4	4.4	4.4			
		5.5	5.49	5.4	5.4	5.4			
			3.0		2.56	2.4	2.46	V	* $V_{IN} = V_{IL}$ or V_{IH} -12 mA I_{OH} -24 mA -24 mA
			4.5		3.86	3.7	3.76		
			5.5		4.86	4.7	4.76		
V_{OL}	Maximum Low Level Output Voltage	3.0	0.002	0.1	0.1	0.1	V	$I_{OUT} = 50 \mu\text{A}$	
		4.5	0.001	0.1	0.1	0.1			
		5.5	0.001	0.1	0.1	0.1			
			3.0		0.36	0.50	0.44	V	* $V_{IN} = V_{IL}$ or V_{IH} 12 mA I_{OL} 24 mA 24 mA
			4.5		0.36	0.50	0.44		
			5.5		0.36	0.50	0.44		

*All outputs loaded; thresholds on input associated with output under test.

DC Electrical Characteristics for 'ACQ Family Devices (Continued)

Symbol	Parameter	V _{CC} (V)	74ACQ		54ACQ	74ACQ		Units	Conditions
			T _A = +25°C		T _A = -55°C to +125°C	T _A = -40°C to +85°C			
			Typ	Guaranteed Limits					
I _{IN}	Maximum Input Leakage Current	5.5		±0.1	±1.0		±1.0	μA	V _I = V _{CC} , GND (Note 1)
I _{OLD}	† Minimum Dynamic Output Current	5.5			50		75	mA	V _{OLD} = 1.65V Max
I _{OHD}		5.5			-50		-75	mA	V _{OHD} = 3.85V Min
I _{CC}	Maximum Quiescent Supply Current	5.5		8.0	160.0		80.0	μA	V _{IN} = V _{CC} or GND (Note 1)
I _{OZ}	Maximum TRI-STATE Leakage Current	5.5		±0.5	±10.0		±5.0	μA	V _I (OE) = V _{IL} , V _{IH} V _I = V _{CC} , GND V _O = V _{CC} , GND
V _{OLP}	Quiet Output Maximum Dynamic V _{OL}	5.0	1.1	1.5				V	Figures 1, 2 (Notes 2, 3)
V _{OLV}	Quiet Output Minimum Dynamic V _{OL}	5.0	-0.6	-1.2				V	Figures 1, 2 (Notes 2, 3)
V _{IHD}	Minimum High Level Dynamic Input Voltage	5.0	3.1	3.5				V	(Notes 2, 4)
V _{I LD}	Maximum Low Level Dynamic Input Voltage	5.0	1.9	1.5				V	(Notes 2, 4)

*All outputs loaded; thresholds on input associated with output under test.

†Maximum test duration 2.0 ms, one output loaded at a time.

Note 1: I_{IN} and I_{CC} @ 3.0V are guaranteed to be less than or equal to the respective limit @ 5.5V V_{CC}.

I_{CC} for 54ACQ @ 25°C is identical to 74ACQ @ 25°C.

Note 2: Worst case package.

Note 3: Max number of outputs defined as (n). Data inputs are driven 0V to 5V. One output @ GND.

Note 4: Maximum number of data inputs (n) switching. (n - 1) inputs switching 0V to 5V ('ACQ). Input-under-test switching: 5V to threshold (V_{I LD}), 0V to threshold (V_{I HD}). f = 1 MHz.

DC Electrical Characteristics for 'ACTQ Family Devices

Symbol	Parameter	V _{CC} (V)	74ACTQ		54ACTQ	74ACTQ	Units	Conditions
			T _A = +25°C		T _A = -55°C to +125°C	T _A = -40°C to +85°C		
			Typ	Guaranteed Limits				
V _{IH}	Minimum High Level Input Voltage	4.5 5.5	1.5 1.5	2.0 2.0	2.0 2.0	2.0 2.0	V	V _{OUT} = 0.1V or V _{CC} - 0.1V
V _{IL}	Maximum Low Level Input Voltage	4.5 5.5	1.5 1.5	0.8 0.8	0.8 0.8	0.8 0.8	V	V _{OUT} = 0.1V or V _{CC} - 0.1V
V _{OH}	Minimum High Level Output Voltage	4.5 5.5	4.49 5.49	4.4 5.4	4.4 5.4	4.4 5.4	V	I _{OUT} = -50 μA
		4.5 5.5		3.85 4.86	3.70 4.70	3.76 4.76	V	*V _{IN} = V _{IL} or V _{IH} -24 mA I _{OH} -24 mA
V _{OL}	Maximum Low Level Output Voltage	4.5 5.5	0.001 0.001	0.1 0.1	0.1 0.1	0.1 0.1	V	I _{OUT} = 50 μA
		4.5 5.5		0.36 0.36	0.50 0.50	0.44 0.44	V	*V _{IN} = V _{IL} or V _{IH} 24 mA I _{OL} 24 mA
I _{IN}	Maximum Input Leakage Current	5.5		±0.1	±1.0	±1.0	μA	V _I = V _{CC} , GND
I _{OZ}	Maximum TRI-STATE Leakage Current	5.5		±0.5	±10.0	±5.0	μA	V _I = V _{IL} , V _{IH} V _O = V _{CC} , GND
I _{CC}	Maximum I _{CC} /Input	5.5	0.6		1.6	1.5	mA	V _I = V _{CC} - 2.1V
I _{OLD}	†Maximum Dynamic Output Current	5.5			50	75	mA	V _{OLD} = 1.65V Max
I _{OHD}		5.5			-50	-75	mA	V _{OHD} = 3.85V Min
I _{CC}	Maximum Quiescent Supply Current	5.5		8.0	160.0	80.0	μA	V _{IN} = V _{CC} or GND (Note 1)
V _{OLP}	Maximum High Level Output Noise	5.0	1.1	1.5			V	Figures 1, 2 (Notes 2, 3)
V _{OLV}	Maximum Low Level Output Noise	5.0	-0.6	-1.2			V	Figures 1, 2 (Notes 2, 3)
V _{IHD}	Maximum High Level Dynamic Input Voltage	5.0	1.9	2.2			V	(Notes 2, 4)
V _{ILD}	Maximum Low Level Dynamic Input Voltage	5.0	1.2	0.8			V	(Notes 2, 4)

*All outputs loaded; thresholds on input associated with output under test.

†Maximum test duration 2.0 ms, one output loaded at a time.

Note 1: I_{CC} for 54ACTQ @ 25°C is identical to 74ACTQ @ 25°C.

Note 2: Worst case package.

Note 3: Max number of outputs defined as (n). Data inputs are driven 0V to 3V. One output @ GND.

Note 4: Maximum number of data inputs (n) switching. (n - 1) inputs switching 0V to 3V ('ACTQ). Input-under-test switching: 3V to threshold (V_{ILD}), 0V to threshold (V_{IHD}). f = 1 MHz.

AC Electrical Characteristics

Symbol	Parameter	V _{CC} * (V)	74ACQ			54ACQ		74ACQ		Units
			T _A = +25°C C _L = 50 pF			T _A = -55°C to +125°C C _L = 50 pF		T _A = -40°C to +85°C C _L = 50 pF		
			Min	Typ	Max	Min	Max	Min	Max	
f _{max}	Maximum Clock Frequency	3.3 5.0			120			110	MHz	
t _{PLH} , t _{PHL}	Propagation Delay CP to O _n	3.3 5.0			9.5			10.5	ns	
t _{PZH} , t _{PZL}	Output Enable Time OE to O _n	3.3 5.0			11.0			12.0	ns	
t _{PHZ} , t _{PLZ}	Output Disable Time OE to O _n	3.3 5.0			12.0			13.0	ns	
t _{OSLH} , t _{OSHL}	Output to Output Skew** CP to O _n	3.3 5.0		1.0 0.5	1.5 1.0			1.5 1.0	ns	

*Voltage Range 3.3 is 3.3V ±0.3V

Voltage Range 5.0 is 5.0V ±0.5V

**Skew is defined as the absolute value of the difference between the actual propagation delay for any two outputs within the same packaged device. The specification applies to any outputs switching in the same direction, either HIGH to LOW (t_{OSHL}) or LOW to HIGH (t_{OSLH}). Parameter guaranteed by design. Not tested.

AC Operating Requirements

Symbol	Parameter	V _{CC} * (V)	74ACQ		54ACQ		74ACQ		Units
			T _A = +25°C C _L = 50 pF		T _A = -55°C to +125°C C _L = 50 pF		T _A = -40°C to +85°C C _L = 50 pF		
			Typ	Guaranteed Minimum					
t _s	Setup Time, HIGH or LOW D _n to CP	3.3 5.0		3.0			3.0	ns	
t _h	Hold Time, HIGH or LOW D _n to CP	3.3 5.0		1.5			1.5	ns	
t _w	CP Pulse Width HIGH or LOW	3.3 5.0		5.0			5.0	ns	

*Voltage Range 3.3 is 3.3V ±0.3V

Voltage Range 5.0 is 5.0V ±0.5V

AC Electrical Characteristics

Symbol	Parameter	V _{CC} * (V)	74ACTQ			54ACTQ		74ACTQ		Units
			T _A = +25°C C _L = 50 pF			T _A = -55°C to +125°C C _L = 50 pF		T _A = -40°C to +85°C C _L = 50 pF		
			Min	Typ	Max	Min	Max	Min	Max	
f _{max}	Maximum Clock Frequency	5.0			120			110	MHz	
t _{PLH} , t _{PHL}	Propagation Delay CP to O _n	5.0	3.0	6.5	9.5			2.5	10.5	ns
t _{PZH} , t _{PZL}	Output Enable Time OE to O _n	5.0	3.0	7.5	10.5			2.5	11.5	ns
t _{PHZ} , t _{PLZ}	Output Disable Time OE to O _n	5.0	1.0	6.5	8.5			1.0	9.0	ns
t _{OSLH} , t _{OSHL}	Output to Output Skew** CP to O _n	5.0		0.5	1.0				1.0	ns

*Voltage Range 5.0 is 5.0V ± 0.5V

**Skew is defined as the absolute value of the difference between the actual propagation delay for any two outputs within the same packaged device. The specification applies to any outputs switching in the same direction, either HIGH to LOW (t_{OSHL}) or LOW to HIGH (t_{OSLH}). Parameter guaranteed by design. Not tested.

AC Operating Requirements

Symbol	Parameter	V _{CC} * (V)	74ACTQ		54ACTQ		74ACTQ		Units
			T _A = +25°C C _L = 50 pF		T _A = -55°C to +125°C C _L = 50 pF		T _A = -40°C to +85°C C _L = 50 pF		
			Typ	Guaranteed Minimum					
t _s	Setup Time, HIGH or LOW D _n to CP	5.0		3.0			3.0	ns	
t _h	Hold Time, HIGH or LOW D _n to CP	5.0		1.5			1.5	ns	
t _w	CP Pulse Width HIGH or LOW	5.0		4.5			5.5	ns	

*Voltage Range 5.0 is 5.0V ± 0.5V

Capacitance

Symbol	Parameter	Typ	Units	Conditions
C _{IN}	Input Capacitance	4.5	pF	V _{CC} = 5.0V
C _{PD}	Power Dissipation Capacitance	55.0	pF	V _{CC} = 5.0V

FACT Noise Characteristics

The setup of a noise characteristics measurement is critical to the accuracy and repeatability of the tests. The following is a brief description of the setup used to measure the noise characteristics of FACT.

Equipment:

Hewlett Packard Model 8180A Word Generator
 PC-163A Test Fixture
 Tektronics Model 7854 Oscilloscope

Procedure:

1. Verify Test Fixture Loading: Standard Load 50 pF, 500Ω.
2. Deskew the word generator so that no two channels have greater than 150 ps skew between them. This requires that the oscilloscope be deskewed first. Swap out the channels that have more than 150 ps of skew until all channels being used are within 150 ps. It is important to deskew the word generator channels before testing. This will ensure that the outputs switch simultaneously.
3. Terminate all inputs and outputs to ensure proper loading of the outputs and that the input levels are at the correct voltage.
4. Set V_{CC} to 5.0V.
5. Set the word generator to toggle all but one output at a frequency of 1 MHz. Greater frequencies will increase DUT heating and affect the results of the measurement.

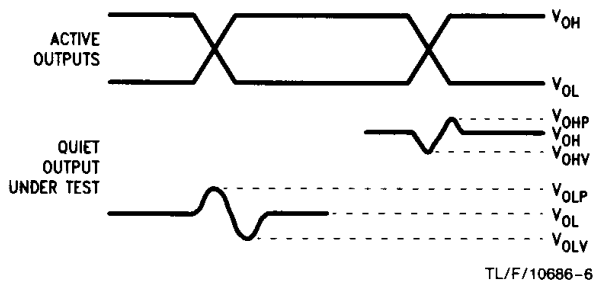

FIGURE 8. Quiet Output Noise Voltage Waveforms

Note A: V_{OHV} and V_{OLP} are measured with respect to ground reference.

Note B: Input pulses have the following characteristics: $f = 1$ MHz, $t_r = 3$ ns, $t_f = 3$ ns, skew < 150 ps.

6. Set the word generator input levels at 0V LOW and 3V HIGH for ACT devices and 0V LOW and 5V HIGH for AC devices. Verify levels with a digital volt meter.

V_{OLP}/V_{OLV} and V_{OHP}/V_{OHV} :

- Determine the quiet output pin that demonstrates the greatest noise levels. The worst case pin will usually be the furthest from the ground pin. Monitor the output voltages using a 50Ω coaxial cable plugged into a standard SMB type connector on the test fixture. Do not use an active FET probe.
- Measure V_{OLP} and V_{OLV} on the quiet output during the HL transition. Measure V_{OHP} and V_{OHV} on the quiet output during the LH transition.
- Verify that the GND reference recorded on the oscilloscope has not drifted to ensure the accuracy and repeatability of the measurements.

V_{ILD} and V_{IHD} :

- Monitor one of the switching outputs using a 50Ω coaxial cable plugged into a standard SMB type connector on the test fixture. Do not use an active FET probe.
- First increase the input LOW voltage level, V_{IL} , until the output begins to oscillate. Oscillation is defined as noise on the output LOW level that exceeds V_{IL} limits, or on output HIGH levels that exceed V_{IH} limits. The input LOW voltage level at which oscillation occurs is defined as V_{ILD} .
- Next increase the input HIGH voltage level on the word generator, V_{IH} until the output begins to oscillate. Oscillation is defined as noise on the output LOW level that exceeds V_{IL} limits, or on output HIGH levels that exceed V_{IH} limits. The input HIGH voltage level at which oscillation occurs is defined as V_{IHD} .
- Verify that the GND reference recorded on the oscilloscope has not drifted to ensure the accuracy and repeatability of the measurements.

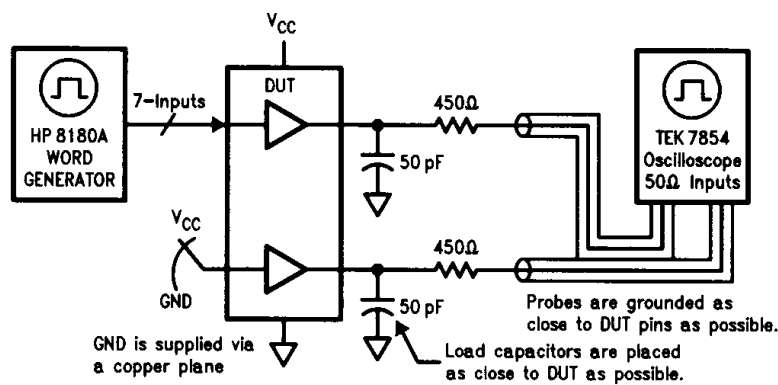
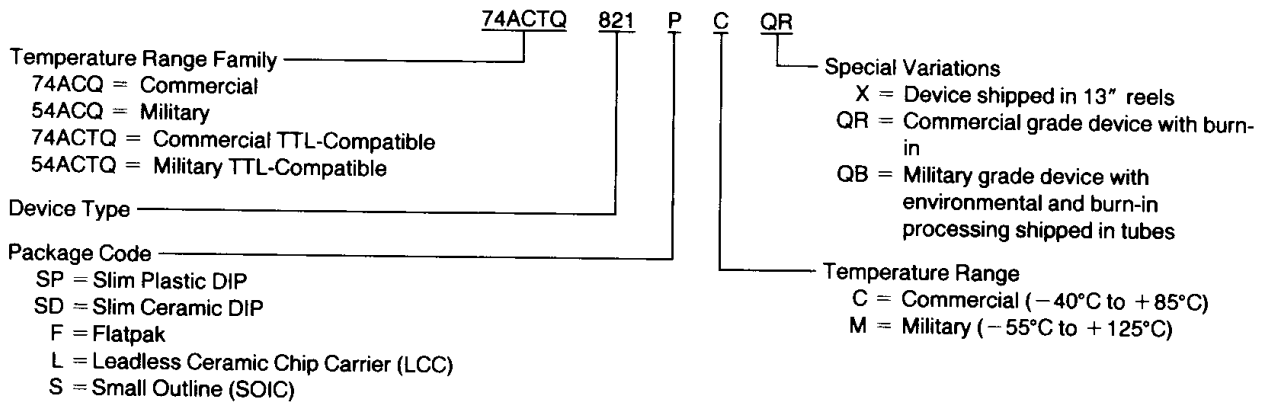

FIGURE 9. Simultaneous Switching Test Circuit

Ordering Information

The device number is used to form part of a simplified purchasing code where the package type and temperature range are defined as follows:



Physical Dimensions inches (millimeters)

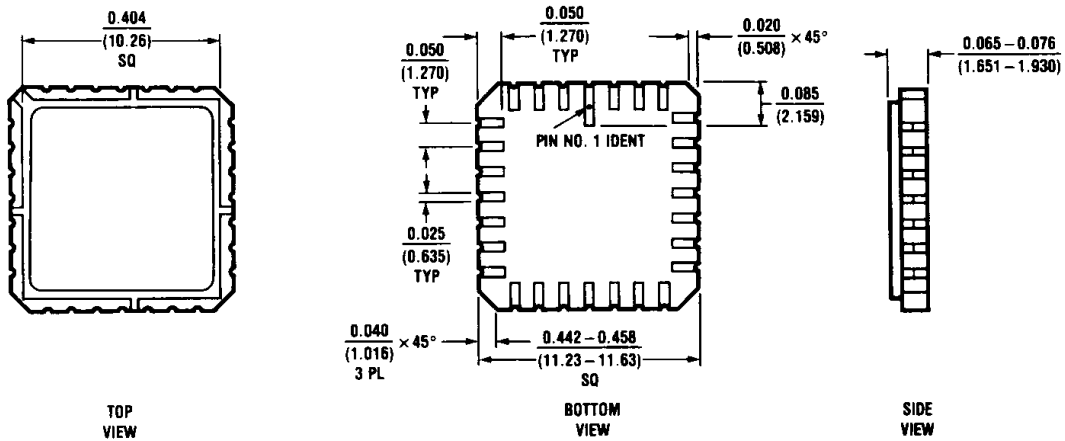

**28 Terminal Ceramic Leadless Chip Carrier (L)
NS Package Number E28A**

E28A (REV C)

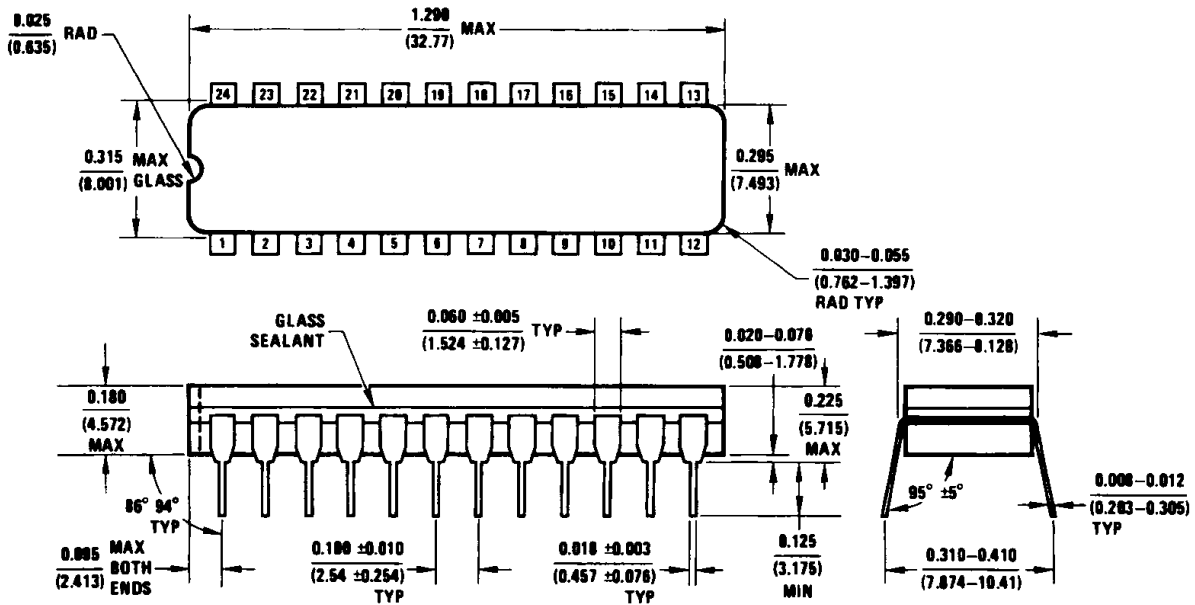

**24 Lead Slim (0.300" Wide) Ceramic Dual-In-Line Package (SD)
NS Package Number J24F**

J24F (REV G)