



8-Bit Microcontroller for Monitor

Features

- Operating voltage range: 4.5V to 5.5V
- CMOS technology for low power consumption
- 6502 8-bit CMOS CPU core
- 8 MHz operation frequency
- 32K/24K/16K bytes of ROM
- 512 bytes of RAM
- One 8-bit base timer
- 13 channels of 8-bit PWM outputs with 5V open drain
- 4 channel A/D converters with 6-bit resolution
- 25 bi-directional I/O port pins (8 dedicated I/O pins)
- Hsync/Vsync signals processor for separate & composite signals which includes hardware sync signals polarity detection and frequency counters with 2 sets of Hsync counting intervals
- Hsync/Vsync polarity controlled output, 5 selectable free run output signals and self-test patterns, auto-mute function, half freq. I/O function
- Add a jitter filter at the front end of Hsync input path, reduce the jitter interference of Hsync input
- Two built-in I²C bus interfaces support VESA DDC1/2B+
- Two layers of interrupt management
 - NMI interrupt sources
 - INTE0 (External INT with selectable edge trigger)
 - INTMUTE (Auto Mute Activated)
 - IRQ interrupt sources
 - INTS0/1 (SCL Go-low INT)
 - INTA0/1 (Slave Address Matched INT)
 - INTTX0/1 (Shift Register INT)
 - INTRX0/1 (Shift Register INT)
 - INTNAK0/1 (No Acknowledge)
 - INTSTOP0/1 (Stop Condition Occurred INT)
 - INTE1 (External INT with Selectable Edge Trigger)
 - INTV (VSYNC INT)
 - INTMR (Base Timer INT)
 - INTADC (AD Conversion Done INT)
- Hardware Watch-dog timer function
- 40-pin P-DIP and 42-pin S-DIP packages

General Description

The NT6862 is a new generation monitor μ C for auto-sync and digital control applications. Particularly, this chip supports various and efficient functions to allow users to easily develop USB monitors. It contains the 6502 8-bit CPU core, 512 bytes of RAM used as working RAM and stack area, 32K bytes of OTP ROM, 13-channels of 8-bit PWM D/A converters, 4-channel A/D converters for key detection which save I/O pins, one 8-bit pre-loadable base timer, internal Hsync and Vsync signals processor, a Watch-dog timer which prevents the system from abnormal

operation, and two I²C bus interfaces. The user can store EDID data in the 128 bytes of RAM for DDC1/2B, so that user can reduce a dedicated EEPROM for EDID. A Half frequency output function can save external one-shot circuit. These designs are committed to reduce component cost. The 42 pin S-DIP IC provides two additional I/O pins – port40 & port41, Part number NT6862U represents the S-DIP IC. For future reference, port40 & port42 are only available for the 42 pin S-DIP IC.

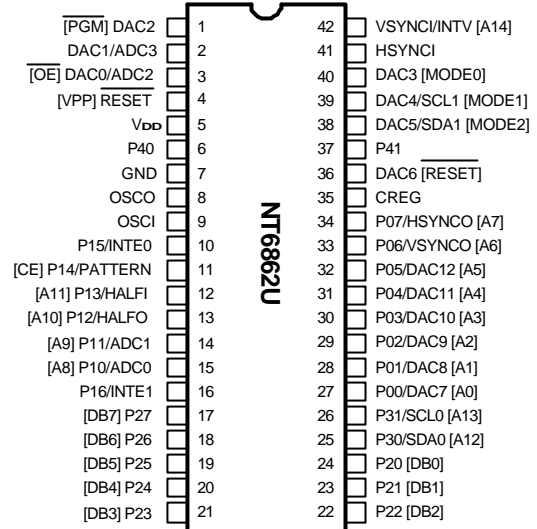
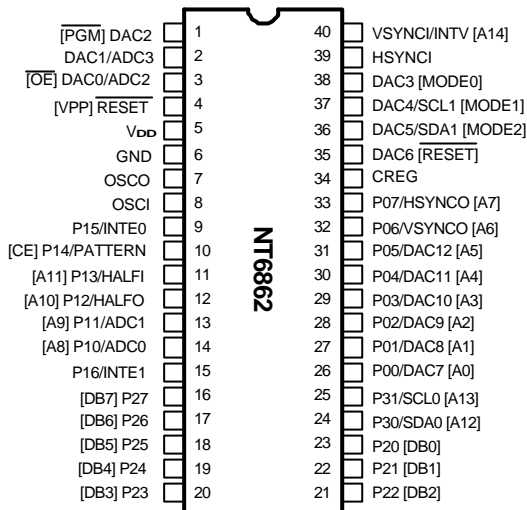
Pin Configurations
40-Pin P-DIP

* []: OTP Mode

* []: OTP Mode

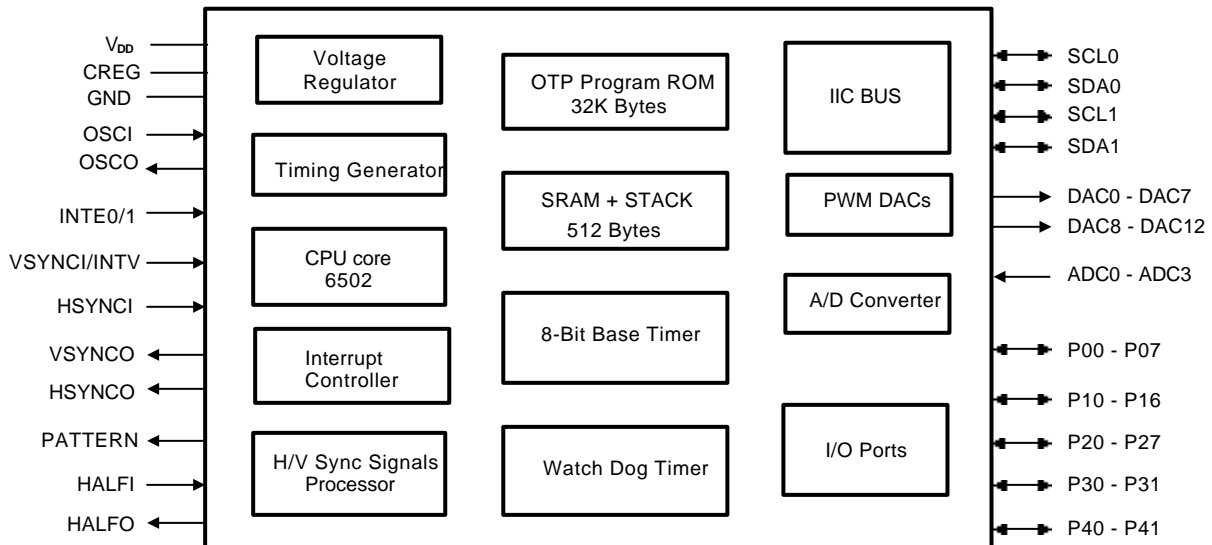
42-Pin S-DIP
Block Diagram

Pin Description

Pin No.		Designation	Reset Init.	I/O	Description
40 Pin	42 Pin				
1	1	DAC2 [$\overline{\text{PGM}}$]		O [I]	Open drain 5V, D/A converter output 2 [OTP ROM program control]
2	2	DAC1/ADC3	DAC1	O	Open drain 5V, D/A converter output 1, shared with A/D converter channel 3 input
3	3	DAC0/ADC2 [$\overline{\text{OE}}$]	DAC0	O	Open drain 5V, D/A converter output 0, shared with A/D converter channel 2 input [OTP ROM program output enable]
4	4	$\overline{\text{RESET}}$ [VPP]		I [P]	Schmitt Trigger input pin, low active reset with internal pulled down 50K Ω register * [OTP ROM program supply voltage]
5	5	V _{DD}		P	Power
6	7	GND		P	Ground
7	8	OSCO		O	Crystal OSC output
8	9	OSCI		I	Crystal OSC input
9	10	P15/INTE0		I/O	Bi-directional I/O pin with internally pulled up 22K Ω register, shared with input pin of external interrupt source0 (NMI), with Schmitt Trigger, selectable triggered, and internally pulled up 22K Ω register
10	11	P14/PATTERN [A15/CE]		I/O [I]	Bi-directional I/O pin with internally pulled up 22K Ω register, shared with the output of self test pattern [OTP ROM program address buffer & chip enable]
11	12	P13/HALFI [A11]	P13	I/O [I]	Bi-directional I/O pin with internally pulled up 22K Ω register, shared with half Hsync input. [OTP ROM program address buffer]
12	13	P12/HALFO [A10]	P12	I/O [I]	Bi-directional I/O pin with internally pulled up 22K Ω register, shared with half Hsync output [OTP ROM program address buffer]
13	14	P11/ADC1 [A9]	P11	I/O [I]	Bi-directional I/O pin with internally pulled up 22K Ω register, shared with A/D converter channel 1 input [OTP ROM program address buffer]
14	15	P10/ADC0 [A8]	P10	I/O [I]	Bi-directional I/O pin with internally pulled up 22K Ω register, shared with A/D converter channel 0 input [OTP ROM program address buffer]
15	16	P16/INTE1	P16	I/O	Bi-directional I/O pin with internally pulled up 22K Ω register, shared with input pin of external interrupt source1, with Schmitt Trigger, selectable triggered, and an internal pulled up 22K Ω register

Pin Description (continued)

Pin No.		Designation	Reset Init.	I/O	Description
40 Pin	42 Pin				
16 - 23	17 - 24	P27 – P20 [DB7] – [DB0]		I/O [I/O]	Bi-directional I/O pin, push-pull structure with high current drive/sink capability [OTP ROM program data buffer]
24	25	P30/SDA0 [A12]	P30	I/O [I]	Open drain 5V bi-directional I/O pin P30, shared with SDA0 pin of I ² C bus Schmitt Trigger buffer [OTP ROM program address buffer]
25	26	P31/SCL0 [A13]	P31	I/O [I]	Open drain 5V bi-directional I/O pin P31, shared with SCL0 pin of I ² c bus Schmitt Trigger buffer [OTP ROM program address buffer]
26	27	P00/DAC7 [A0]	P00	I/O [I]	Bi-directional I/O pin with internally pulled up 22K Ω register, shared with open drain 5V D/A converter output 8 [OTP ROM program address buffer]
27	28	P01/DAC8 [A1]	P01	I/O [I]	Bi-directional I/O pin with internally pulled up 22K Ω register, shared with open drain 5V D/A converter output 9 [OTP ROM program address buffer]
28	29	P02/DAC9 [A2]	P02	I/O [I]	Bi-directional I/O pin with internally pulled up 22K Ω register, shared with open drain 5V D/A converter output 10 [OTP ROM program address buffer]
29	30	P03/DAC10 [A3]	P03	I/O [I]	Bi-directional I/O pin with internally pulled up 22K Ω register, shared with open drain 5V D/A converter output 11 [OTP ROM program address buffer]
30	31	P04/DAC11 [A4]	P04	I/O [I]	Bi-directional I/O pin with internally pulled up 22K Ω register, shared with open drain 5V D/A converter output 12 [OTP ROM program address buffer]
31	32	P05/DAC12 [A5]	P05	I/O [I]	Bi-directional I/O pin with internally pulled up 22K Ω register, shared with open drain 5V D/A converter output 13 [OTP ROM program address buffer]
32	33	P06/VSYNCO [A6]	P06	I/O [I]	Bi-directional I/O pin with internally pulled up 22K Ω register, shared with vsync out [OTP ROM program address buffer]
33	34	P07/HSYNCO [A7]	P07	I/O [I]	Bi-directional I/O pin with internally pulled up 22K Ω register, shared with hsync out [OTP ROM program address buffer]
34	35	CREG		O	On chip voltage regulator output. [Connect external regulating cap. (10 μ F - 100 μ F) here]
35	36	DAC6 [RESET]		O [I]	Open drain 5V, D/A converter output 6 [OTP ROM reset]

Pin Description (continued)

Pin No.		Designation	Reset Init.	I/O	Description
40 Pin	42 Pin				
36	38	DAC5/SDA1 [MODE2]		O [1]	Open drain 5V, D/A converter output 5, shared with open drain SDA1 line of I ² C bus, Schmitt Trigger buffer [OTP ROM mode select]
37	39	DAC4/SCL1 [MODE1]		O [1]	Open drain 5V, D/A converter output 4, shared with open drain SCL1 line of I ² C bus, Schmitt Trigger buffer [OTP ROM mode select]
38	40	DAC3 [MODE0]		O [1]	Open drain 5V, D/A converter output 3 [OTP ROM mode select]
39	41	HSYNCl		I	Debouncing & Schmitt Trigger input pin for video horizontal sync signal internally pulled high, shared with composite sync input. A jitter filter is added at the front end, it could effectually reduce the jitter interference of external noisy Hsync input.
40	42	VSYNCl/INTV [A14]	VSYNCl	I [1]	Debouncing & Schmitt Trigger input pin for video vertical sync signal, internal pull high, shared with input pin of external interrupt source intv with Schmitt Trigger, selectable triggered, and internal pulled up 22K Ω register [OTP ROM program address buffer]
-	6	P40		I/O	Bi-directional I/O pin with internal pulled up 22K Ω register, only 42 pin S-DIP available
-	37	P41		I/O	Bi-directional I/O pin with internal pulled up 22K Ω register, only 42 pin S-DIP available

* This $\overline{\text{RESET}}$ pin must be pulled high by an external pulled-up register (5K Ω suggestion), or it will remain in low voltage and continually keep the system in a rest state..

Functional Description
1. 6502 CPU

The 6502 is an 8-bit CPU that provides 56 instructions, decimal and binary arithmetic, thirteen addressing modes, true indexing capability, programmable stack pointer and variable length stack, a wide selection of addressable memory ranges, and interrupt input options.

The CPU clock cycle is 4MHz (8MHz system clock divided by 2). Please refer to the 6502 data sheet for more detailed information.

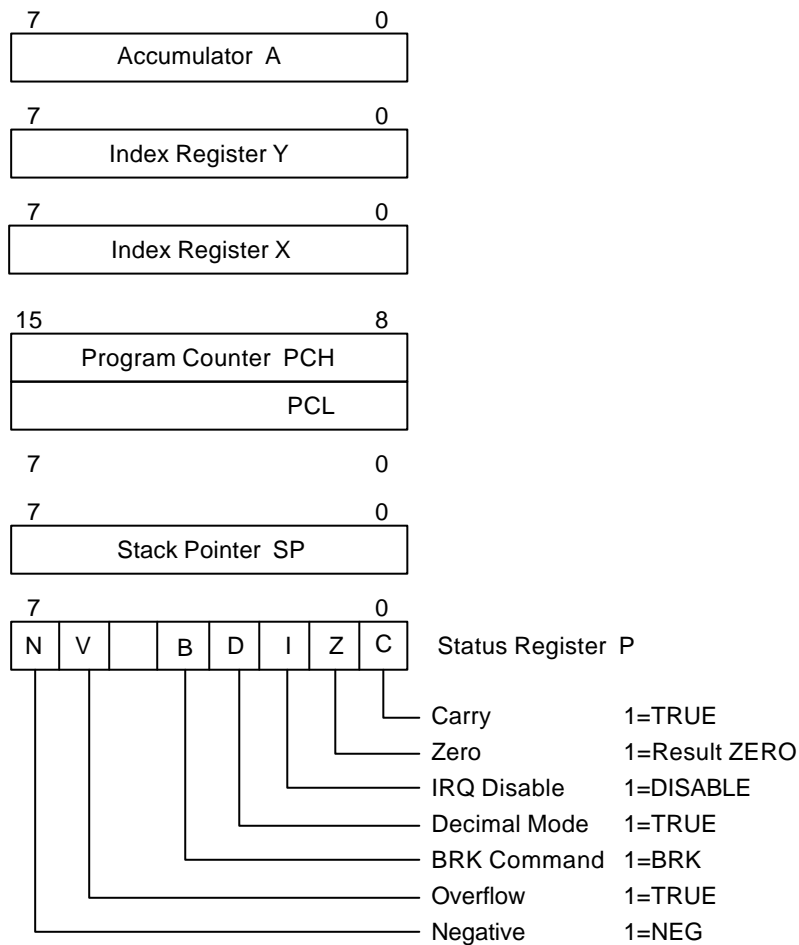

Figure 1.1. The 6502 CPU Registers and Status Flags

2. Instruction Set List

Instruction Code	Meaning	Operation
ADC	Add with carry	$A + M + C \rightarrow A, C$
AND	Logical AND	$A \wedge M \rightarrow A$
ASL	Shift left one bit	$C \leftarrow M_7 \dots M_0 \leftarrow 0$
BCC	Branch if carry clears	Branch on $C = 0$
BCS	Branch if carry sets	Branch on $C = 1$
BEQ	Branch if equal to zero	Branch on $Z = 1$
BIT	Bit test	$A \wedge M, M_7 \rightarrow N, M_6 \rightarrow V$
BMI	Branch if minus	Branch on $N = 1$
BNE	Branch if not equal to zero	Branch on $Z = 0$
BPL	Branch if plus	Branch on $N = 0$
BRK	Break	Forced Interrupt $PC+2 \rightarrow PC$
BVC	Branch if overflow clears	Branch on $V = 0$
BVS	Branch if overflow sets	Branch on $V = 1$
CLC	Clear carry	$0 \rightarrow C$
CLD	Clear decimal mode	$0 \rightarrow D$
CLI	Clear interrupt disable bit	$0 \rightarrow I$
CLV	Clear overflow	$0 \rightarrow V$
CMP	Compare Accumulator to memory	$A - M$
CPX	Compare with index register X	$X - M$
CPY	Compare with index register Y	$Y - M$
DEC	Decrement memory by one	$M - 1 \rightarrow M$
DEX	Decrement index X by one	$X - 1 \rightarrow X$
DEY	Decrement index Y by one	$Y - 1 \rightarrow Y$
EOR	Logical exclusive-OR	$A \oplus M \rightarrow A$
INC	Increment memory by one	$M + 1 \rightarrow M$
INX	Increment index X by one	$X + 1 \rightarrow X$
INY	Increment index Y by one	$Y + 1 \rightarrow Y$

Instruction Set List (continued)

Instruction Code	Meaning	Operation
JMP	Jump to new location	(PC+1) PCL, (PC+2) PCH
JSR	Jump to subroutine	PC+2, (PC+1) PCL, (PC+2) PCH
LDA	Load accumulator with memory	M A
LDX	Load index register X with memory	M X
LDY	Load index register Y with memory	M Y
LSR	Shift right one bit	0 M7 ..M0 C
NOP	No operation	No operation (2 cycles)
ORA	Logical OR	A + M A
PHA	Push accumulator on stack	A
PHP	Push status register on stack	P
PLA	Pull accumulator from stack	A
PLP	Pull status register from stack	P
ROL	Rotate left through carry	C M7 ..M0 C
ROR	Rotate right through carry	C M7 ..M0 C
RTI	Return from interrupt	P, PC
RTS	Return from subroutine	PC, PC+1 PC
SBC	Subtract with borrow	A - M - C A, C
SEC	Set carry	1 C
SED	Set decimal mode	1 D
SEI	Set interrupt disable status	1 I
STA	Store accumulator in memory	A M
STX	Store index register X in memory	X M
STY	Store index register Y in memory	Y M
TAX	Transfer accumulator to index X	A X
TAY	Transfer accumulator to index Y	A Y
TSX	Transfer stack pointer to index X	S X
TXA	Transfer index X to accumulator	X A
TXS	Transfer index X to stack pointer	X S
TYA	Transfer index Y to accumulator	Y A

* Refer to 6502 programming data book for more details.

3. RAM: 512 X 8 bits

The built-in 512 X 8-bit SRAM is used for data memory and stack area. The RAM addressing range is from \$0080 to \$027F. The contents of RAM are undetermined at power-up and are not affected by system reset. Software programmers can allocate stack area in the RAM by setting stack pointer register (S). Because the 6502 default stack pointer is \$01FF, programmers must set S register to FFH when starting the program.

```
as;  LDX  #$FF
      TXS
```

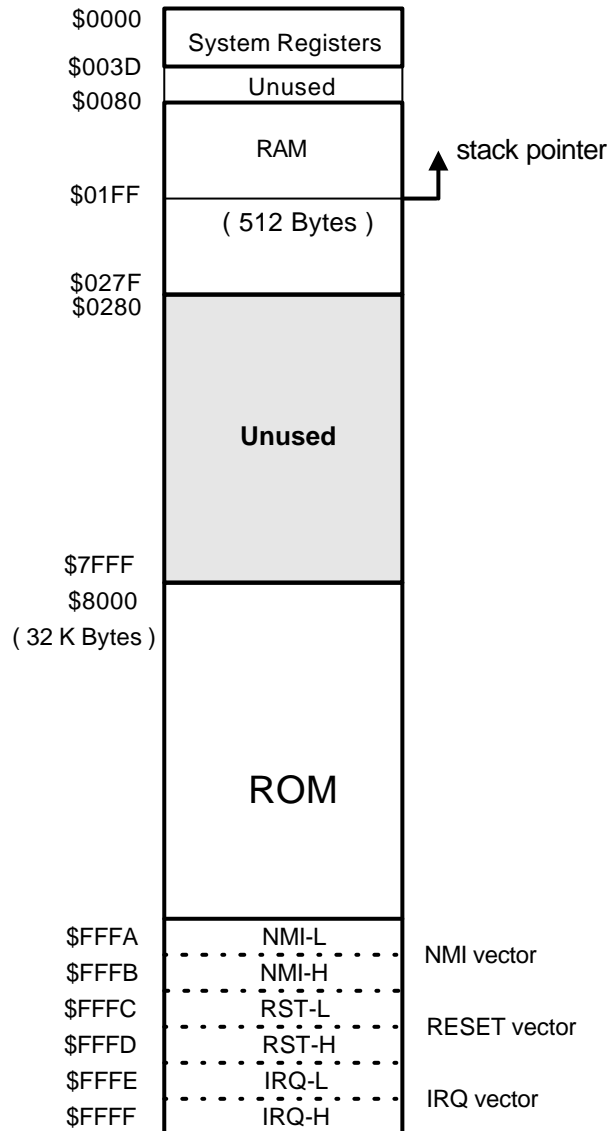

4. ROM: 32K X 8 bits

NT6862 provides maximum 32K ROM space for code. The ROM space is located from \$8000 to \$FFFF. The addresses, from \$FFFA to \$FFFF, are reserved for the 6502 CPU vectors, thus users must arrange them separately.

5. System Registers

Addr.	Register	INIT	Bit7	Bit6	Bit5	Bit4	Bit3	Bit2	Bit1	Bit0	R/W
Control Registers for I/O Port0 & Port1											
\$0000	PT0	FFH	P07	P06	P05	P04	P03	P02	P01	P00	RW
\$0001	PT1	7FH	-	P16	P15	P14	P13	P12	P11	P10	RW
Control Register to Control Port2 I/O Direction											
\$0002	PT2DIR	FFH	$\overline{P27OE}$	$\overline{P26OE}$	$\overline{P25OE}$	$\overline{P24OE}$	$\overline{P23OE}$	$\overline{P22OE}$	$\overline{P21OE}$	$\overline{P20OE}$	W
Control Registers for I/O Port2 - 4											
\$0003	PT2	FFH	P27	P26	P25	P24	P23	P22	P21	P20	RW
\$0004	PT3	03H	-	-	-	-	-	-	P31	P30	RW
\$0005	PT4	03H	Only available for the 42 Pin SDIP version					-	P41	P40	RW
Control Registers for Synprocessor											
\$0006	SYNCON	FFH	-	-	-	-	\overline{INSEN}	-	\overline{HSEL}	S/ \overline{C}	R
		FFH	-	-	-	-	\overline{INSEN}	\overline{ENHSEL}	\overline{HSEL}	S/ \overline{C}	W
\$0007	HV CON	FFH	-	-	HSYNCI	VSYNCI	HPOLI	VPOLI	HPOLO	VPOLO	R
		FFH	\overline{ENHOUT}	\overline{ENHOUT}	-	-	-	-	HPOLO	VPOLO	W
\$0008	HCNT L	00H	HCL7	HCL6	HCL5	HCL4	HCL3	HCL2	HCL1	HCL0	R
\$0009	HCNT H	00H	HCNTOV	-	-	-	HCH3	HCH2	HCH1	HCH0	R
			CLRHOV	-	-	-	-	-	-	-	W
\$000A	VCNT L	00H	VCL7	VCL6	VCL5	VCL4	VCL3	VCL2	VCL1	VCL0	R
\$000B	VCNT H	00H	VCNTOV	-	VCH5	VCH4	VCH3	VCH2	VCH1	VCH0	R
			CLRVOV	-	-	-	-	-	-	-	W
\$000C	FREECON	FFH	\overline{ENPAT}	$\overline{PAT1}$	-	-	-	$\overline{FREQ2}$	$\overline{FREQ1}$	$\overline{FREQ0}$	W
\$000D	HALFCON	FFH	\overline{ENHALF}	\overline{NOHALF}	$\overline{HALFPOL}$	-	-	-	-	-	W
\$000E	AUTOMUTE	FFH	$\overline{ENHDIFF}$	\overline{ENPOL}	\overline{ENOVER}	-	HDIFFVL3	HDIFFVL2	HDIFFVL1	HDIFFVL0	W
Control Registers to Enable PWM 7 - 12 Channels											
\$000F	ENDAC	FFH	-	-	$\overline{ENDK12}$	$\overline{ENDK11}$	$\overline{ENDK10}$	$\overline{ENDK9}$	$\overline{ENDK8}$	$\overline{ENDK7}$	W
Control Registers for ADC 0 - 3 Channels											
\$0010	ENADC	FFH	\overline{CSTA}	-	-	-	$\overline{ENADC3}$	$\overline{ENADC2}$	$\overline{ENADC1}$	$\overline{ENADC0}$	W
\$0011	AD0 REG	C0H	-	-	AD05	AD04	AD03	AD02	AD01	AD00	R
\$0012	AD1 REG	00H	-	-	AD15	AD14	AD13	AD12	AD11	AD10	R
\$0013	AD2 REG	00H	-	-	AD25	AD24	AD23	AD22	AD21	AD20	R
\$0014	AD3 REG	00H	-	-	AD35	AD34	AD33	AD32	AD31	AD30	R

System Registers (continued)

Addr.	Register	INIT	Bit7	Bit6	Bit5	Bit4	Bit3	Bit2	Bit1	Bit0	R/W
Control Register for Polling (Read) Interrupt Groups & Clearing (Write) INTE0 & INTMUTE Interrupt Requests											
\$0016	NMIPOLL	00H	-	-	-	-	-	-	INTE0	INTMUTE	R
			-	-	-	-	-	-	CLRE0	CLRMUTE	W
\$0017	IRQPOLL	00H	-	-	-	-	-	IRQ2	IRQ1	IRQ0	R
Control Registers of Interrupt Enable											
\$0018	IENMI	00H	-	-	-	-	-	-	INTE0	INTMUTE	RW
\$0019	IEIRQ0	00H	-	-	INTS0	INTA0	INTTX0	INTRX0	INTNAK0	INTSTOP0	RW
\$001A	IEIRQ1	00H	-	-	INTS1	INTA1	INTTX1	INTRX1	INTNAK1	INTSTOP1	RW
\$001B	IEIRQ2	00H	-	-	-	-	INTADC	INTV	INTE1	INTMR	RW
Control Registers for Polling (Read) & Clearing (Write) Interrupt Requests											
\$001C	IRQ0	00H	-	-	INTS0	INTA0	INTTX0	INTRX0	INTNAK0	INTSTOP0	R
			-	-	CLRS0	CLRA0	CLRTX0	CLRRX0	CLRNAK0	CLRSTOP0	W
\$001D	IRQ1	00H	-	-	INTS1	INTA1	INTTX1	INTRX1	INTNAK1	INTSTOP1	R
			-	-	CLRS1	CLRA1	CLRTX1	CLRRX1	CLRNAK1	CLRSTOP1	W
\$001E	IRQ2	00H	-	-	-	-	INTADC	INTV	INTE1	INTMR	R
			-	-	-	-	CLRADC	CLRV	CLRE1	CLRMR	W
Selection of Edge Triggered for INTV, INTE0 & 1 Interrupts											
\$001F	TRIGGER	FFH	-	-	-	-	-	INTVR	INTE1R	INTE0R	R/W
Control Registers for Clearing Watch Dog Timer											
\$0020	CLR WDT	-	0	1	0	1	0	1	0	1	W
Control Register for DDC1/2B+ of Channel 0											
\$0021	CH0ADDR	A0H	ADR7	ADR6	ADR5	ADR4	ADR3	ADR2	ADR1	-	W
\$0022	CH0TXDAT	00H	TX7	TX6	TX5	TX4	TX3	TX2	TX1	TX0	W
\$0023	CH0RXDAT	00H	RX7	RX6	RX5	RX4	RX3	RX2	RX1	RX0	R
\$0024	CH0CON	E0H	$\overline{\text{ENDDC}}$	$\text{MD1}/\overline{2}$	-	START	STOP	-	$\overline{\text{TXACK}}$	-	W
			-	-	$\overline{\text{SRW}}$	START	STOP	-	-	-	R
\$0025	CH0CLK	FFH	$\overline{\text{MODE}}$	$\overline{\text{MRW}}$	$\overline{\text{RSTART}}$	-	-	DDC2BR2	DDC2BR1	DDC2BR0	W
Control Register for DDC1/2B+ of Channel 1											
\$0026	CH1ADDR	A0H	ADR7	ADR6	ADR5	ADR4	ADR3	ADR2	ADR1	-	W
\$0027	CH1TXDAT	00H	TX7	TX6	TX5	TX4	TX3	TX2	TX1	TX0	W
\$0028	CH1RXDAT	00H	RX7	RX6	RX5	RX4	RX3	RX2	RX1	RX0	R

System Registers (continued)

Addr.	Register	INIT	Bit7	Bit6	Bit5	Bit4	Bit3	Bit2	Bit1	Bit0	R/W
\$0029	CH1CON	E0H	$\overline{\text{ENDDC}}$	$\text{MD1}/\overline{2}$	-	START	STOP	-	$\overline{\text{TXACK}}$	-	W
			-	-	$\overline{\text{SRW}}$	START	STOP	-	-	-	R
\$002A	CH1CLK	FFH	$\overline{\text{MODE}}$	$\overline{\text{MRW}}$	$\overline{\text{RSTART}}$	-	-	DDC2BR2	DDC2BR1	DDC2BR0	W
Control Registers for Base Timer											
\$002E	BT	00H	BT7	BT6	BT5	BT4	BT3	BT2	BT1	BT0	W
\$002F	BTCON	03H	-	-	-	-	-	-	$\overline{\text{BTCLK}}$	$\overline{\text{ENBT}}$	W
Control Registers for PWM Channel 0 - 12											
\$0030	DACH0	80H	DKVL7	DKVL6	DKVL5	DKVL4	DKVL3	DKVL2	DKVL1	DKVL0	RW
\$0031	DACH1	80H	DKVL7	DKVL6	DKVL5	DKVL4	DKVL3	DKVL2	DKVL1	DKVL0	RW
\$0032	DACH2	80H	DKVL7	DKVL6	DKVL5	DKVL4	DKVL3	DKVL2	DKVL1	DKVL0	RW
\$0033	DACH3	80H	DKVL7	DKVL6	DKVL5	DKVL4	DKVL3	DKVL2	DKVL1	DKVL0	RW
\$0034	DACH4	80H	DKVL7	DKVL6	DKVL5	DKVL4	DKVL3	DKVL2	DKVL1	DKVL0	RW
\$0035	DACH5	80H	DKVL7	DKVL6	DKVL5	DKVL4	DKVL3	DKVL2	DKVL1	DKVL0	RW
\$0036	DACH6	80H	DKVL7	DKVL6	DKVL5	DKVL4	DKVL3	DKVL2	DKVL1	DKVL0	RW
\$0037		-	-	-	-	-	-	-	-	-	
\$0038	DACH7	80H	DKVL7	DKVL6	DKVL5	DKVL4	DKVL3	DKVL2	DKVL1	DKVL0	RW
\$0039	DACH8	80H	DKVL7	DKVL6	DKVL5	DKVL4	DKVL3	DKVL2	DKVL1	DKVL0	RW
\$003A	DACH9	80H	DKVL7	DKVL6	DKVL5	DKVL4	DKVL3	DKVL2	DKVL1	DKVL0	RW
\$003B	DACH10	80H	DKVL7	DKVL6	DKVL5	DKVL4	DKVL3	DKVL2	DKVL1	DKVL0	RW
\$003C	DACH11	80H	DKVL7	DKVL6	DKVL5	DKVL4	DKVL3	DKVL2	DKVL1	DKVL0	RW
\$003D	DACH12	80H	DKVL7	DKVL6	DKVL5	DKVL4	DKVL3	DKVL2	DKVL1	DKVL0	RW

6. Timing Generator

This block generates the system timing and control signal to be supplied to the CPU and on-chip peripherals. A crystal quartz, ceramic resonator, or an external clock signal which will be provided to the OSCI pin generates system timing. It generates 8MHz system clock, 4MHz for the CPU. Although internal circuits have a feedback resistor

and capacitor included, users can externally add these components for proper operating.

The typical clock frequency is 8MHz. Different frequencies will affect the operation of those on-chip peripherals whose operating frequency is based on the system clock.

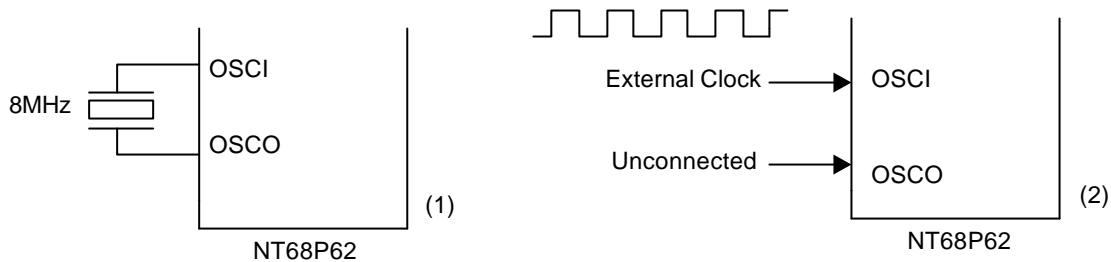

Figure 6.1. Oscillator Connections

7. RESET

The NT6862 can be reset by the external reset pin or by the internal Watch-dog timer. This is used to reset or start the microcontroller from a POWER DOWN condition. During the time that this reset pin is held LOW, writing to or from the μC is inhibited. (*The reset line must be held LOW for at least two CPU clock cycles) When a positive edge is detected on the RESET input, the μC will immediately begin the reset sequence.

After a system initialization time of six CPU clock cycles, the mask interrupt flag will be set and the μC will load the program counter from the memory vector locations \$FFFC and \$FFFD. This is the start location for program control.

An internal Schmitt Trigger buffer at the $\overline{\text{RESET}}$ pin is provided to improve noise immunity.

The reset status is as follows:

1. PORT0、PORT1、PORT2、PORT3 (& PORT4) pins will act as I/O ports with HIGH output
2. Sync processor counters reset and VCNT | HCNT latches cleared
3. All sync outputs are disabled
4. Base timer is disabled and cleared
5. Various Interrupt sources are disabled and cleared
6. A/D converter is disabled and stopped
7. DDC1/2B+ function is disabled
8. PWM DAC0 – DAC6 output 50% duty waveform and DAC7 - DAC12 is disabled
9. Watch-dog timer is cleared and enabled

8. A/D Converters

The structure of these analog to digital converters is 6-bit successive approximation. Analog voltage is supplied from external sources to the A/D input pins and the result of the conversion is stored in the 6-bit data latch registers (\$0011 & \$0014). The A/D channels are activated by clearing the correspondent control bits in the ENADC control register. When users write '0' to one of the enable control bits, its correspondent I/O pin or DAC will be switched to the A/D converter input pin (ADC0 & ADC1 shared with PORT10 & PORT 11; ADC2 & ADC3 shared with DAC0 & DAC1).

Conversion will be started by clearing \overline{CSTA} bit

(CONVERSION START) in the ENADC control register. When conversion is finished, system will set this INTADC bit. Users can monitor this bit to get the valid A/D conversion data in the AD latch registers (\$0011 - \$0014). Users can also open interrupt sources to remind users to get the stable digital data. Note that latched data is only available at the activated A/D channel.

The analog voltage to be measured should be stabled during the conversion operation and the variation will not exceed LSB for the best accuracy in measurement.

Addr.	Register	INIT	Bit7	Bit6	Bit5	Bit4	Bit3	Bit2	Bit1	Bit0	R/W
\$0010	ENADC	FFH	\overline{CSTA}	-	-	-	$\overline{ENADC3}$	$\overline{ENADC2}$	$\overline{ENADC1}$	$\overline{ENADC0}$	W
\$0011	AD0 REG	C0H	-	-	AD05	AD04	AD03	AD02	AD01	AD00	R
\$0012	AD1 REG	00H	-	-	AD15	AD14	AD13	AD12	AD11	AD10	R
\$0013	AD2 REG	00H	-	-	AD25	AD24	AD23	AD22	AD21	AD20	R
\$0014	AD3 REG	00H	-	-	AD35	AD34	AD33	AD32	AD31	AD30	R
\$001B	IEIRQ2	00H	-	-	-	-	INTADC	INTV	INTE1	INTMR	R/W
\$001E	IRQ2	00H	-	-	-	-	INTADC	INTV	INTE1	INTMR	R
			-	-	-	-	CLRADC	CLRV	CLRE1	CLRMR	W

Reference ADC Table ($V_{DD} = 5.0V$)

15	1.53V	1C	2.07V	23	2.62V	2A	3.16V
16	1.62V	1D	2.16V	24	2.70V	2B	3.25V
17	1.69V	1E	2.23V	25	2.77V	2C	3.33V
18	1.76V	1F	2.31V	26	2.85V	2D	3.40V
19	1.84V	20	2.39V	27	2.93V	2E	3.48V
1A	1.92V	21	2.47V	28	3.01V	2F	3.56V
1B	2.00V	22	2.54V	29	3.09V	30	3.64V

Note: It is strongly recommended that the ADC's input signal should be allocated in the ADC's linear voltage range (1.5V - 3.5V) to obtain a stable digital value. Do not use the outer ranges (0V - 1.4V & 3.6V - 5.0V) in which the converted digital value is not guaranteed.

9. PWM DACs (Pulse Width Modulation D/A Converters)

There are 13 PWM D/A converters with 8-bit resolution in NT6862. All of these D/A (DAC0 - DAC12) converters are open-drain output structure with an external 5V applied maximum. DAC0 – DAC6 are dedicated PWM channels, and DAC7 - DAC12 are shared with I/O pins. Those shared PWM channels are activated by clearing the correspondent control bits in the ENDAC control register (\$000F). When users write '0' into one of the enable control bits, its correspondent I/O pin will be switched to PWM output pin.

The PWM refresh rate is 62.5KHz operating on 8MHz system clock. There are 13 readable DACH registers corresponding to 13 PWM channels (\$0030 - \$003D). Each PWM output pulse width is programmable by setting the 8 bit digital to the corresponding DACH registers. When these DACH registers are set to 00H, the DAC will output LOW (GND level) and every 1 bit addition will add 62.5ns pulse width. After reset, all DAC outputs are set to 80H (1/2 duty output). Please refer to Figure 9.1 for the detailed timing diagram of PWM D/A output.

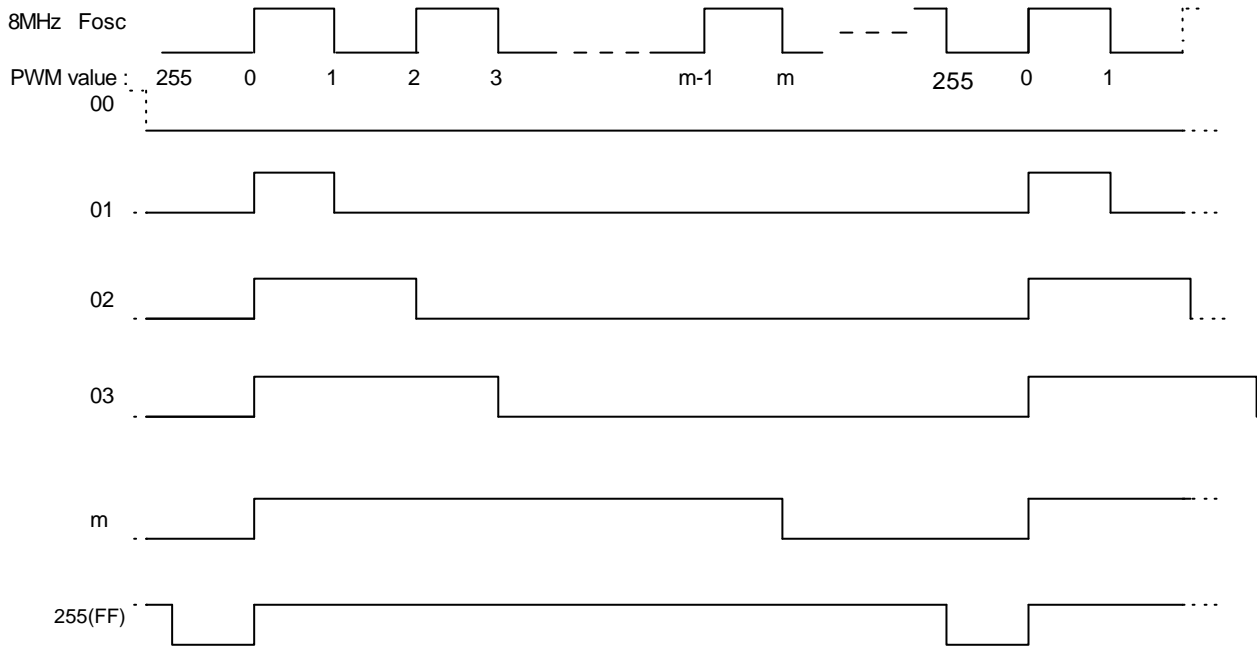

Figure 9.1. The DAC Output Timing Diagram and Wave Table

PWM DACs (continued)

DAC0 & DAC1 are shared with ADC2 & ADC3 input pins respectively. If ENADC2/3 bit in the ENADC control register is cleared to LOW, A/D converters will activate simultaneously. After the chip is reset, ENADC2/3 bits will be in HIGH state and DAC0 & DAC1 will act as PWM output pins.

DAC4 & DAC5 are shared with SCL1 & SDA1 I/O pins respectively. If users clear the ENDDC bit in the CH1CON control register to LOW, channel 1 of DDC will be activated. When used as DDC channel, the I/O port will be an open drain structure and include a Schmitt Trigger buffer for noise immunity. After the chip is reset, ENDDC bits will be in HIGH state and DAC4 - DAC5 will act as PWM output pins.

Addr.	Register	INIT	Bit7	Bit6	Bit5	Bit4	Bit3	Bit2	Bit1	Bit0	R/W
\$000F	ENDAC	FFH	-	-	ENDK12	ENDK11	ENDK10	ENDK9	ENDK8	ENDK7	W
\$0010	ENADC	FFH	CSTA	-	-	-	ENADC3	ENADC2	ENADC1	ENADC0	W
\$0030	DACH0	80H	DKVL7	DKVL6	DKVL5	DKVL4	DKVL3	DKVL2	DKVL1	DKVL0	RW
\$0031	DACH1	80H	DKVL7	DKVL6	DKVL5	DKVL4	DKVL3	DKVL2	DKVL1	DKVL0	RW
\$0032	DACH2	80H	DKVL7	DKVL6	DKVL5	DKVL4	DKVL3	DKVL2	DKVL1	DKVL0	RW
\$0033	DACH3	80H	DKVL7	DKVL6	DKVL5	DKVL4	DKVL3	DKVL2	DKVL1	DKVL0	RW
\$0034	DACH4	80H	DKVL7	DKVL6	DKVL5	DKVL4	DKVL3	DKVL2	DKVL1	DKVL0	RW
\$0035	DACH5	80H	DKVL7	DKVL6	DKVL5	DKVL4	DKVL3	DKVL2	DKVL1	DKVL0	RW
\$0036	DACH6	80H	DKVL7	DKVL6	DKVL5	DKVL4	DKVL3	DKVL2	DKVL1	DKVL0	RW
\$0037		-	-	-	-	-	-	-	-	-	
\$0038	DACH7	80H	DKVL7	DKVL6	DKVL5	DKVL4	DKVL3	DKVL2	DKVL1	DKVL0	RW
\$0039	DACH8	80H	DKVL7	DKVL6	DKVL5	DKVL4	DKVL3	DKVL2	DKVL1	DKVL0	RW
\$003A	DACH9	80H	DKVL7	DKVL6	DKVL5	DKVL4	DKVL3	DKVL2	DKVL1	DKVL0	RW
\$003B	DACH10	80H	DKVL7	DKVL6	DKVL5	DKVL4	DKVL3	DKVL2	DKVL1	DKVL0	RW
\$003C	DACH11	80H	DKVL7	DKVL6	DKVL5	DKVL4	DKVL3	DKVL2	DKVL1	DKVL0	RW
\$003D	DACH12	80H	DKVL7	DKVL6	DKVL5	DKVL4	DKVL3	DKVL2	DKVL1	DKVL0	RW

DAC control register (\$000F) and DAC value register (\$0030 - \$003D)

10. Watch-Dog Timer (WDT)

The NT6862 implements a Watch-dog timer reset to avoid system stop or malfunction. The clock of the WDT is from on-chip RC oscillator which does not require any external components. Thus, the WDT will run, even if the clock on the OSCI/OSCO pins of the device have been stopped. The WDT time interval is about 0.5 second. The WDT must

be cleared within every 0.5 second when the software is in normal sequence, otherwise the WDT will overflow and cause a reset. The WDT is cleared and enabled after the system is reset, and can not be disabled by the software. Users can clear the WDT by writing 55H to CLRWDT register (\$0020).

```
as;  LDA  #$55
      STA  $0020
```

Addr.	Register	INIT	Bit7	Bit6	Bit5	Bit4	Bit3	Bit2	Bit1	Bit0	R/W
\$0020	CLR WDT	-	0	1	0	1	0	1	0	1	W

11. Interrupt Controller

The system provides two kinds of interrupt sources: NMI & IRQ. The NMI can not be masked and if enabling NMI interrupt sources, users can execute the NMI interrupt vector anytime when sources are activated. The IRQ interrupts can be masked by executing a CLI instruction or setting the interrupt mask flag directly in the μ C status register. In process IRQ interrupt, if the interrupt mask flag is not set, the μ C will begin an interrupt sequence. The program counter and processor status register will be stored in the stack. The μ C will then set the interrupt mask flag HIGH so that no further interrupts may occur. At the end of this cycle, the program counter will be loaded from addresses \$FFFE & \$FFFF, then transferring program control to the memory vector located at these addresses. For NMI interrupt, μ C will transfer execution sequence to the memory vector located at addresses \$FFFA & \$FFFB.

When manipulating various interrupt sources, NT6862 divides them into two groups for accessing them easily. One is NMI group and the other is IRQ group.

- The NMI group includes INTE0, INTMUTE.
- The IRQ group includes subgroup of IRQ0, IRQ1, IRQ2:
 - IRQ0: DDC1/2B+ Channel 0 interrupt sources; It includes INTS0, INTA0, INTTX0, INTRX0, INTNAK0 and INTSTOP0 interrupts.
 - IRQ1: DDC1/2B+ Channel 1 interrupt sources; It includes INTS0, INTA1, INTTX1, INTRX1, INTNAK1 and INTSTOP1.
 - IRQ2: It includes INTADC, INTV, INTE1 and INTMR interrupt sources.

The interrupt sources are shown below.

Nonmaskable Interrupt Group:

Interrupt	Meaning	Action
INTE0 INT	External 0 INT	It will be activated by the rising edge or falling edge of external interrupt pulse. The triggered edge can be selected by EDGE0 bit.
INTMUTE	Auto Mute	It will be activated when the mute condition occurs (Hsync frequency change). Please refer the synprocessor section for more details.

Maskable Interrupt Group:

Interrupt	Meaning	Action
INTADC	A/D Conversion Done	User activates the ADC by clearing the $\overline{\text{CSTART}}$ bit. When AD conversion is done, this bit will be set.
INTV INT	Vsync INT	It will be activated as the rising edge of every Vsync pulse.
INTE1 INT	External 1 INT	It will be activated by the rising edge or falling edge of external interrupt pulse. The triggered edge can be selected by EDGE1 bit.
INTMR INT	Timer INT	It will be activated as the rising edge of every when the Base Timer counter overflows and counting from \$FF to \$00.

DDC Channel 0/1 Maskable Interrupt Sources:

Interrupt	Meaning	Action
INTS INT	SCL Go-Low INT	In DDC1 mode, it will be activated when the external device proceed a DDC2 communication. This action includes pull the SCL line to ground or send out an 'START' condition directly. System will respond to this action by changing DDC1 mode to DDC2 SLAVE mode.
INTA INT	Address Matched INT	It will be activated at DDC2 slave mode when the external device call NT6862 slave address. If this calling address matches the NT6862 address, system will generate this interrupt to remind user
INTTX INT	Transfer Buffer Empty INT	It will be activated at DDC2 mode when transmission buffer, IIC_TXDAT, is empty at TRAMMISSION mode.
INTRX INT	Receiving Buffer Overflow INT	It will be activated at DDC2 mode when new data have store in the IIC_RXDAT register at RECEIVE mode.
INTNAK INT	No Acknowledge INT	At transmission mode, this interrupt will be activated when NT6862 have send out one byte data but the external device does not respond an acknowledge bit to it.
INTSTOP INT	DDC2 Stop INT	In SLAVE mode, this interrupt will be activated when the NT6862 receives an 'STOP' condition.

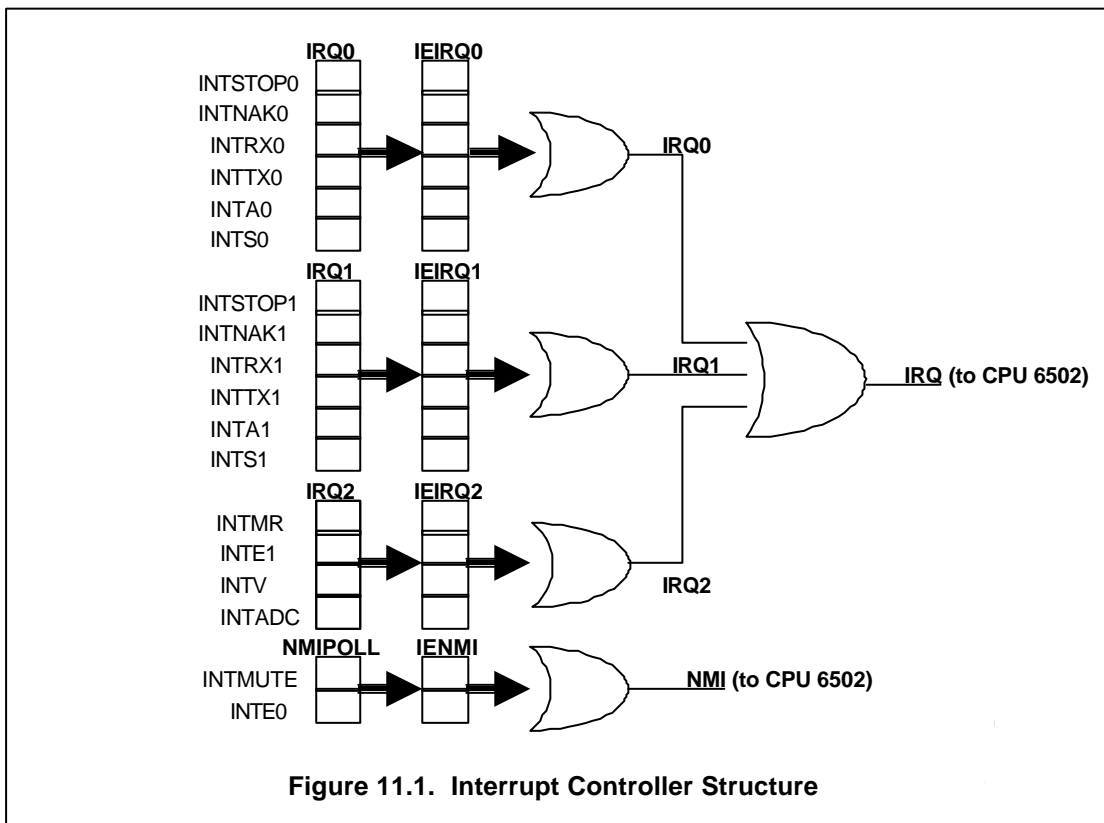

Enabling Interrupts: The system will disable all of these interrupts after reset. Users can enable each of the interrupts by setting the interrupt enable bits at IENMI, IEIRQ0 - IEIRQ3 control registers. For example, if users want to enable external interrupt 0 (INTE0), they should write '1' to INTE0 bit in the IENMI control register. At the INTE0 pin, whenever NT6862 has detected an interrupt message, it will generate an interrupt sequence to fetch the NMI vector. Because these IEX control registers can be read, users can read back what interrupts they have been activated. At polling sequence, users need not poll those unactivated interrupts.

To request interrupts to be set: Regardless whether the user has set the interrupt enable bits or not, if the interrupt triggered condition is matched, the system will set the correspondent bits in the IRQ0 - IRQ3 control registers or in the NMIPOLL control register (INTE0 & INTMUTE bits). For example, if at VSYNCl pin, the system has detected a pulse occurring, system will set the INTV bit in the IRQ2 control register.

Interrupt Groups: System divides IRQ interrupt sources into several groups, ex IRQ0, IRQ1, IRQ2 and IRQ3. At each of these groups, if its membership in the one of the interrupt groups has been activated, its group bit in the IRQPOLL control register will be set. For example, if the INTS0 of the first DDC1/2B+ channel is activated, the INTS0 bit in the IRQ0 will be set and the IRQ0 bit in the IRQPOLL control register also will be set. Notice that the IRQ0 bit will be cleared by system when all of its membership of interrupt sources, INTS0, INTTX0, INTRX0, INTNAK0 and INTSTOP0 have been cleared by the user or system. The NMI group is also operating the same procedure as IRQ groups.

Polling Interrupts: When NMI interrupt occurs, at NMI interrupt service routine, users must poll the INTE0 & INTMUTE bit in the NMIPOLL control register to confirm the NMI interrupt source. The polling sequence decides the priority of NMI interrupt acceptance. When IRQ interrupt occurs, at IRQ interrupt service routine, users must poll the IRQ0 - IRQ3 in the IRQPOLL control register to confirm the IRQ interrupt source. In the same way, the polling sequence decides the priority of IRQ interrupt acceptance. When deciding the IRQ source, users can further confirm the real interrupt source by polling the Correspondent IRQX control register (\$001C - \$001E).

Clearing the Interrupt Request bit: When interrupt occurs, the CPU will jump to the address defined by the interrupt vector to execute interrupt service routine. Users can check which one of the interrupt sources is activated and operating a task. It is that upon entering the interrupt service routine, the request bit that caused the interrupt must be cleared by user before finishing the service routine and returning to normal instruction sequence. If users forget to clear this request bit, after returning to main program, it will interrupt CPU again because the request bit remains activated. Simply, users just need write '1' to the polling bits in the NMIPOLL & IRQX registers (\$0016 & \$001C - \$001E) to clear those completed interrupt sources.

Selecting interrupt triggered edge: At INTV, INTE0 & INTE1 interrupt sources, these are now edge triggered type. System provides the selection of rising or falling edge triggered under user's control. After reset, the rising edge triggered are provided and the content is 'FF' in the TRIGGER control register (\$001F). User just clear control bits in this TRIGGER register and switch these interrupts to falling edge triggered.

Control Bit Description

Addr.	Register	INIT	Bit7	Bit6	Bit5	Bit4	Bit3	Bit2	Bit1	Bit0	R/W
Control Register for Polling Interrupt											
\$0016	NMIPOLL	00H	-	-	-	-	-	-	INTE0	INTMUTE	R
			-	-	-	-	-	-	CLRE0	CLRMUTE	W
\$0017	IRQPOLL	00H	-	-	-	-	-	IRQ2	IRQ1	IRQ0	R
Control Registers of Interrupt Enable											
\$0018	IENMI	00H	-	-	-	-	-	-	INTE0	INTMUTE	RW
\$0019	IEIRQ0	00H	-	-	INTS0	INTA0	INTTX0	INTRX0	INTNAK0	INTSTOP0	RW
\$001A	IEIRQ1	00H	-	-	INTS1	INTA1	INTTX1	INTRX1	INTNAK1	INTSTOP1	RW
\$001B	IEIRQ2	00H	-	-	-	-	INTADC	INTV	INTE1	INTMR	RW
Control Registers for Polling (Read) & Clearing (Write) Interrupt Requests											
\$001C	IRQ0	00H	-	-	INTS0	INTA0	INTTX0	INTRX0	INTNAK0	INTSTOP0	R
			-	-	CLRS0	CLRA0	CLRTX0	CLRRX0	CLRNAK0	CLRSTOP0	W
\$001D	IRQ1	00H	-	-	INTS1	INTA1	INTTX1	INTRX1	INTNAK1	INTSTOP1	R
			-	-	CLRS1	CLRA1	CLRTX1	CLRRX1	CLRNAK1	CLRSTOP1	W
			-	-	-	-	CLRADC	CLRV	CLRE1	CLMR	W
Selection of Edge Triggered for INTE0 & 1 Interrupt											
\$001F	TRIGGER	FFH	-	-	-	-	-	INTVR	INTE1R	INTE0R	R/W

12. I/O PORTS

The NT6862 has 25 pins dedicated to input and output. These pins are grouped into 4 ports.

12.1. PORT0: P00 - P07

PORT0 is an 8-bit bi-directional CMOS I/O port with PMOS as internal pull-up (Figure 12.1). Each pin of PORT0 may be bit programmed as an input or output port without software control the data direction register. When PORT0 works as output, the data to be output are latched to the port data register and output to the pin. PORT0 pins that have '1's written to them are pulled HIGH by the internal PMOS pull-ups. In this state they can be used as input, then the input signal can be read. This port output is HIGH after reset.

P00 - P05 are shared with DAC7 - DAC12 respectively. If $\overline{\text{ENDK7}} - \overline{\text{ENDK12}}$ is set to LOW in ENDAC register, P00 - P05 will act as DAC7 - DAC12 respectively (Figure 12.2).

After the chip is reset, $\overline{\text{ENDK7}} - \overline{\text{ENDK12}}$ will be in the HIGH state and P00 - P05s will act as I/O ports.

P06、P07 are shared with VSYNCO & HSYNCO respectively. If $\overline{\text{ENHOUT}}、\overline{\text{ENVOUT}}$ is set to LOW in HVCON register, P06、P07 will act as VSYNCO & HSYNCO respectively (Figure 12.3). After the chip is reset, $\overline{\text{ENHOUT}} \& \overline{\text{ENVOUT}}$ will be in the HIGH state and P06、P07 will act as I/O pins.

Addr.	Register	INIT	Bit7	Bit6	Bit5	Bit4	Bit3	Bit2	Bit1	Bit0	R/W
\$0000	PT0	FFH	P07	P06	P05	P04	P03	P02	P01	P00	RW
\$0007	HV CON	FFH	-	-	HSYNCI	VSYNCI	HPOLI	VPOLI	HPOLO	VPOLO	R
		FFH	$\overline{\text{ENHOUT}}$	$\overline{\text{ENVOUT}}$	-	-	-	-	HPOLO	VPOLO	W
\$000F	ENDAC	FFH	-	-	$\overline{\text{ENDK12}}$	$\overline{\text{ENDK11}}$	$\overline{\text{ENDK10}}$	$\overline{\text{ENDK9}}$	$\overline{\text{ENDK8}}$	$\overline{\text{ENDK7}}$	W

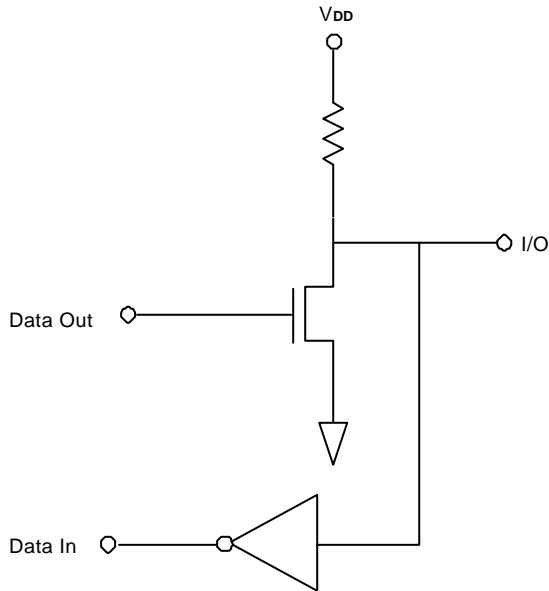

Figure 12.1. I/O Structure

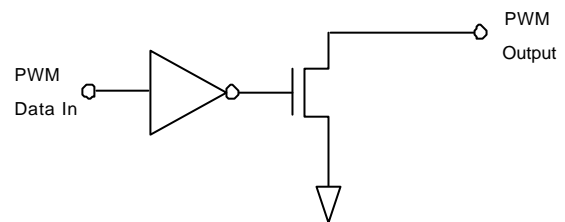

Figure 12.2. PWM Output Structure

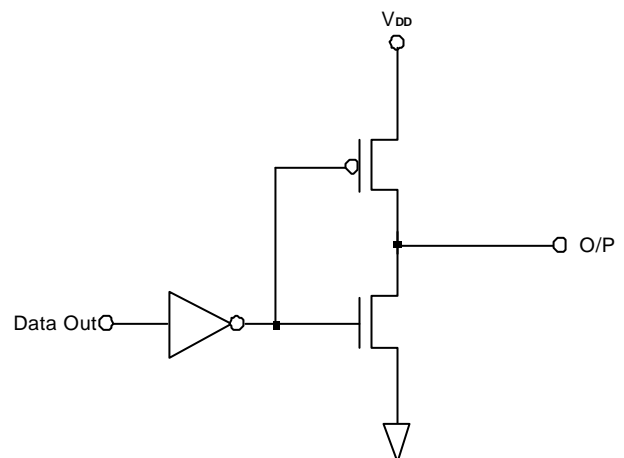

Figure 12.3. Output Structure

12.2. Port1: P10 - P16

PORT10 - PORT16 is a 7-bit bi-directional CMOS I/O port with PMOS as internal pull-up (Figure 12.1). Each bi-directional I/O pin may be bit programmed as an input or output port without software control the data direction register. When PORT1 works as output, the data to be output is latched to the port data register and output to the pin. PORT1 pins that have '1's written to them are pulled HIGH by the internal PMOS pull-ups. In this state they can be used as input, then the input signal can be read. This port output HIGH after reset.

P10 & P11 are shared with AD0 & AD1 input pins respectively. If the ENADC0/1 bit in the ENADC control register is cleared to LOW, A/D converters will activate simultaneously. After the chip is reset, ENADC0/1 bits will be in the HIGH state and P10 - P11 will act as I/O pins.

P12, P13 are shared with HALF SIGNALS input and OUTPUT pins by accessing the OUTCON control register.

If the ENHALF bit is cleared to LOW, P13 will switch to HALFHI pin (input pin) and P12 will switch to HALFHO pin (output pin, Figure 12.3). For HALFHI & HALFHO pin description, please refer half frequency function in the H/V

sync processor paragraph. After the chip is reset, the ENHALF bits will be in HIGH state and P12, P13 will act as I/O pins.

P14 is shared with output pin of self test pattern. If users clear the PATTERN bit in the SYNCON control register and the free running function has been activated, the P14 will switch to output pin of the self test pattern. This pattern output pin is push-pull structure. After the chip is reset, PATTERN bits will be in the HIGH state and P14 will act as I/O pin. (Refer the 'Syncprocessor' section for more detailed information.)

P15 & P16 can be shared with external interrupt INTE0 & INTE1 pins if the INTE0/1 bits are set in the control register of interrupt enable (\$0016 & \$0019). These interrupt pin have 'Schmitt Trigger' input buffers. After the chip is reset, INTE0/1 bits will be in HIGH state and P15 & P16 will act as I/O pin.

Refer 'INTERRUPT CONTROLLER' paragraph above for more details about the interrupt function.

Addr.	Register	INIT	Bit7	Bit6	Bit5	Bit4	Bit3	Bit2	Bit1	Bit0	R/W
\$0001	PT1	7FH	-	P16	P15	P14	P13	P12	P11	P10	RW
\$000C	FREECON	FFH	ENPAT	PAT0	-	-	-	FREQ2	FREQ1	FREQ0	W
\$0010	ENADC	FFH	CSTA	-	-	-	ENADC3	ENADC2	ENADC1	ENADC0	W
\$0018	IENMI	00H	-	-	-	-	-	-	INTE0	INTMUTE	RW
\$001B	IEIRQ2	00H	-	-	-	-	-	INTV	INTE1	INTMR	RW

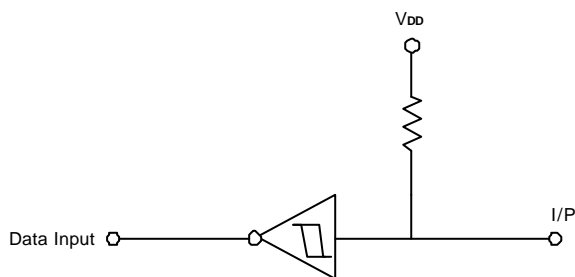

Figure 12.4. Schmitt Input Structure

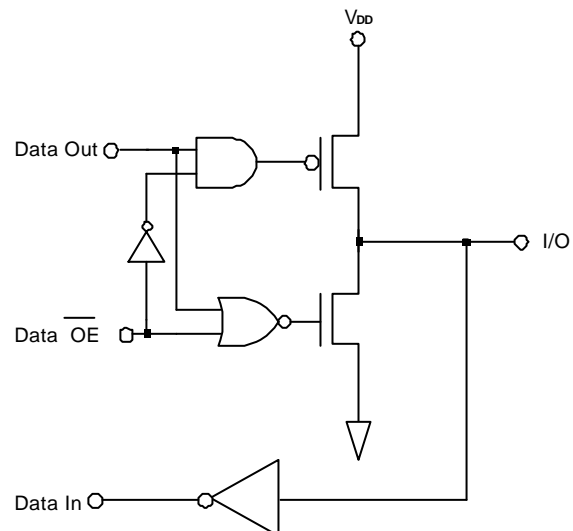

Figure 12.5. I/O Structure

12.3. PORT2: P20 - P27

PORT2, an 8-bit bi-directional I/O port (Figure 12.5), may be programmed as an input or output pin by the software control. When setting the PT2DIR control bit to '0', its correspondent pin will act as an output pin. On the other hand, clear PT2DIR bit to '1', act as input pin. When programmed as an input, it has an internal pull-up resistor. When programmed as an output, the data to be output is latched to the port data register and output to the pin with push-pull structure. This port acts as input port after reset.

Addr.	Register	INIT	Bit7	Bit6	Bit5	Bit4	Bit3	Bit2	Bit1	Bit0	R/W
\$0002	PT2DIR	FFH	$\overline{P27OE}$	$\overline{P26OE}$	$\overline{P25OE}$	$\overline{P24OE}$	$\overline{P23OE}$	$\overline{P22OE}$	$\overline{P21OE}$	$\overline{P20OE}$	W
\$0003	PT2	FFH	P27	P26	P25	P24	P23	P22	P21	P20	RW
\$0010	ENADC	FFH	\overline{CSTA}	-	-	-	$\overline{ENADC3}$	$\overline{ENADC2}$	$\overline{ENADC1}$	$\overline{ENADC0}$	W
\$0029	CH1CON	FFH	\overline{ENDDC}	MD1/2	\overline{SRW}	START	STOP	RXACK	TXACK	-	RW

12.4. PORT3: P30 - P31

PORT3 is an 2 bit bi-directional open-drain I/O port (Figure 12.6). Each pin of PORT3 may be bit programmed as an input or output port with open drain structure. When PORT3 works as output, the data to be output is latched to the port data register and output to the pin. When PORT3 pins that have '1's written to them, users must connect PORT3 with external pulled-up resistor and then PORT3 can be used as input (the input signal can be read). This port output HIGH after reset.

P30、P31 include Schmitt Trigger buffers for noise immunity and can be configured as the I²C pins SDA0 & SCL0 respectively. If set \overline{ENDDC} to LOW in CH0DDC control register, P30、P31 will act as SDA0 & SCL0 I/O pins respectively and will be an open drain structure (Figure 12.6). After the chip is reset, this \overline{ENDDC} bit will be in HIGH state and PORT3 will act as I/O pins.

Addr.	Register	INIT	Bit7	Bit6	Bit5	Bit4	Bit3	Bit2	Bit1	Bit0	R/W
\$0004	PT3	FFH	-	-	-	-	-	-	P31	P30	RW
\$0029	CH1CON	FFH	\overline{ENDDC}	MD1/2	\overline{SRW}	START	STOP	RXACK	TXACK	-	RW

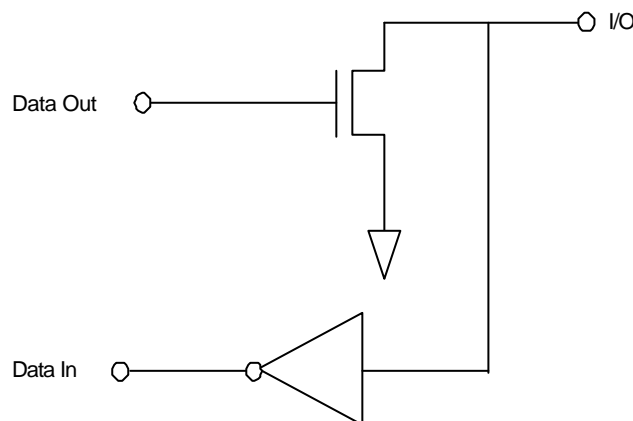

Figure 12.6. PORT3

12.5. PORT4: P40 - P41

PORT4 is available only on the 42pin SDIP IC. PORT40 - PORT41 is an 2-bit bi-directional CMOS I/O port with PMOS as internal pull-up (Figure 12.1). Each bi-directional I/O pin may be bit programmed as an input or output port without software control the data direction register. When PORT4 works as output, the data to be output is latched to the port data register and output to the pin. PORT4 pins that have '1's written to them are pulled HIGH by the internal PMOS pull-ups. In this state they can be used as input. The input signal can be read. This port outputs HIGH after reset.

Addr.	Register	INIT	Bit7	Bit6	Bit5	Bit4	Bit3	Bit2	Bit1	Bit0	R/W
\$0005	PT4	FFH	-	-	-	-	-	-	P41	P40	RW

13. H/V Sync Signals Processor

The functions of the sync processor include polarity detection, Hsync & Vsync signals counting, and programmable sync signals output. It also provides 3-sets of free running signals and special output of test pattern at burn-in process when activating the free running output function. The NT6862 can properly handle either composite or separate sync signal inputs even without sync signal input. As to processing the composite sync signal, a hardware separator will be activated to extract the HSYNC signal under user controlled. The input at HSYNCI can be either a pure horizontal sync signal or a composite sync signal. For the sync waveform refer to Figure 13.1 & Figure 13.2.

The sync processor block diagram is shown in Figure 13.3. The HSYNCI pin contains a jitter filter. For the Hsync signal from VGA card with heavy jitter, the filter could effectually reduce the jitter interference. Both VSYNCI & HSYNCI pins have Schmitt Trigger and filtering process to improve noise immunity. Any pulse that is shorter than 125 ns, will be regarded as a glitch and will be ignored.

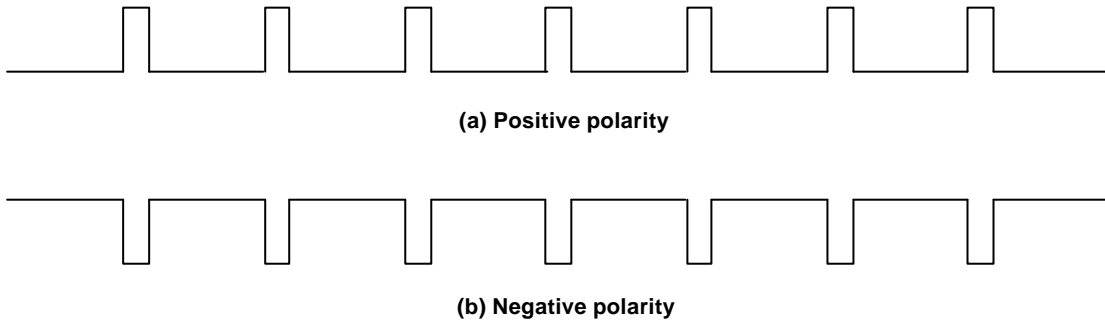

Figure 13.1. Separate H Sync. Waveform

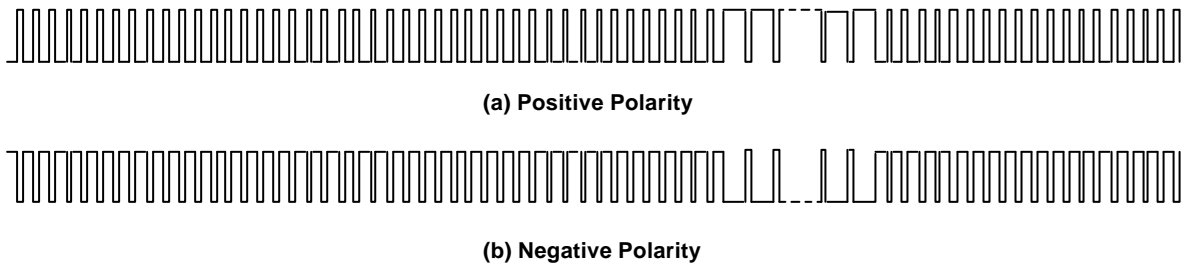

Figure 13.2. Composite H Sync. Waveform

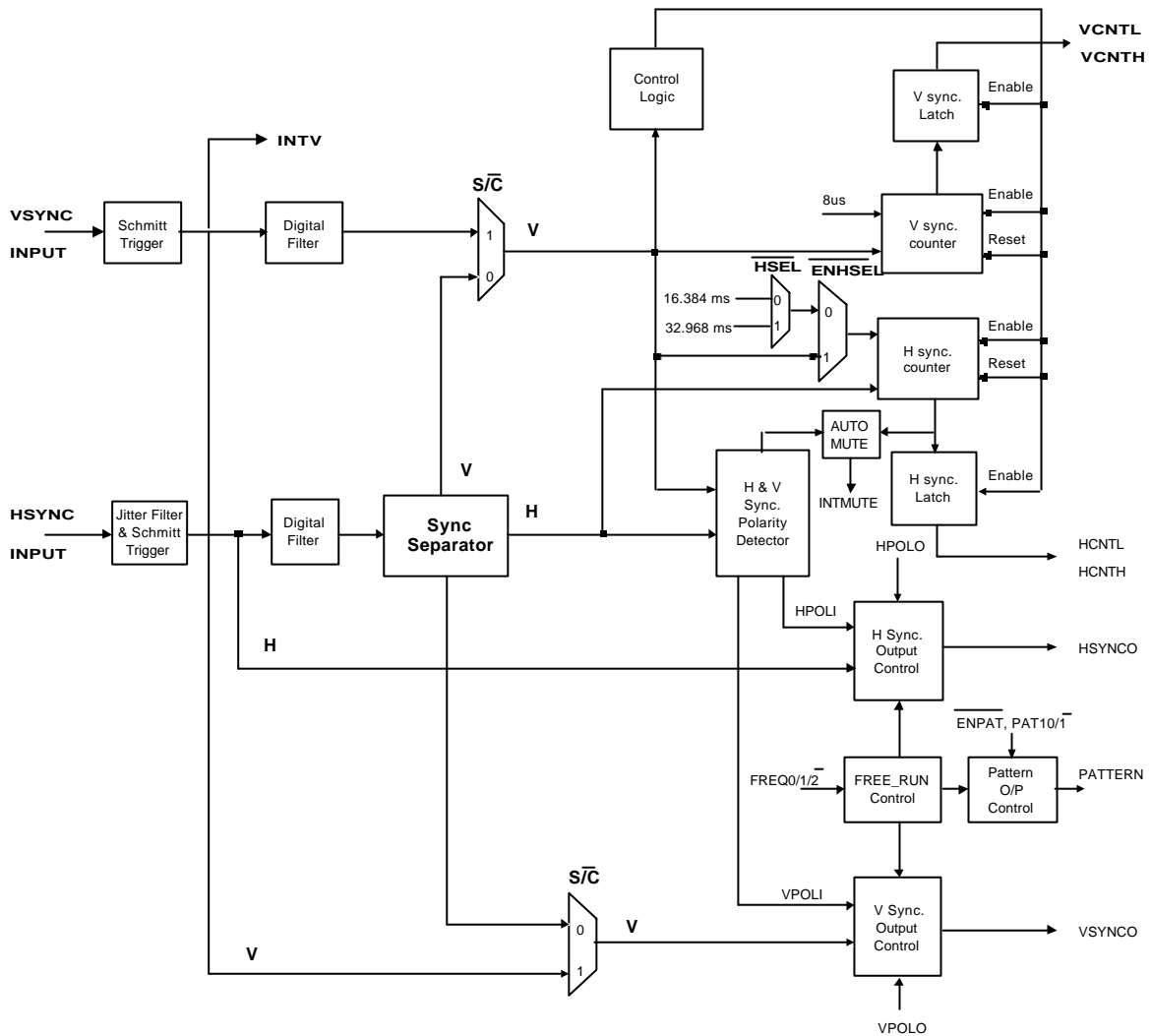

Figure 13.3. Sync. Processor Block Diagram

13.1. V & H Counter Register: VCNTL/H, HCNTL/H

Vsync counter: VCNTL/H, the 14-bit READ ONLY register, contains information of the Vsync frequency. An internal counter counts the numbers of 8us pulse between two VSYNC pulses. When a next VSYNC signal is recognized, the counter is stopped and the VCNTL/H register latches the counter value and then the counter counts from zero again for evaluating next VSYNC time interval. The counted data can be converted to the time duration between two successive Vsync pulses by time 8 us. If no VSYNC incoming, the counter will overflow and set VCNTOV bit (in VCNTL register) to HIGH. Once the VCNTOV set to HIGH, it keeps in the HIGH state until writing '1' to it (CLRVOV bit).

Hsync counter: If the $\overline{\text{ENHSEL}}$ bit is set to HIGH, the internal counter counts the Hsync pulses between two Vsync pulses. The HCNTL/H control registers contain the numbers of Hsync pulse between two Vsync pulses. These data can determine if the Hsync frequency is valid or not to determine the accurate video mode.

The system supports two other options of interval for user counting the frequency of Hsync pulses. If users clear the $\overline{\text{ENHSEL}}$ and set the $\overline{\text{HSEL}}$ bits properly, this internal counter counts the Hsync pulses during this system defined time interval. The time interval is defined below:

$\overline{\text{ENHSEL}}$	$\overline{\text{HSEL}}$	Hsync Freq	Note
1	-	Vsync	After system reset or users disabling
0	0	16.384 ms	
0	1	32.768 ms	

After system reset, this interval will be disabled and the content of $\overline{\text{ENHSEL}}$ & $\overline{\text{HSEL0}}$ bits are '1'. When this function is disabled, the HCNTL/H counter is working on the VSYNC pulse. It is invalid to write '00' to them.

Latching the hsync counter: The counted value will be latched by the HCNTL/H register pairs which are updated by Vsync pulse or system defined time interval. (Refer the Figure 13.4 for the operation of HCNTL/H counter.) If the counter overflows, the HCNTOV bit (in HCNTL register) will be set to HIGH. Once the HCNTOV is set to HIGH, it keeps in the HIGH state until writing '1' to it (CLRHOV bit). When setting this CLRHOV bit, the HCNT counter will not be reset to zero.

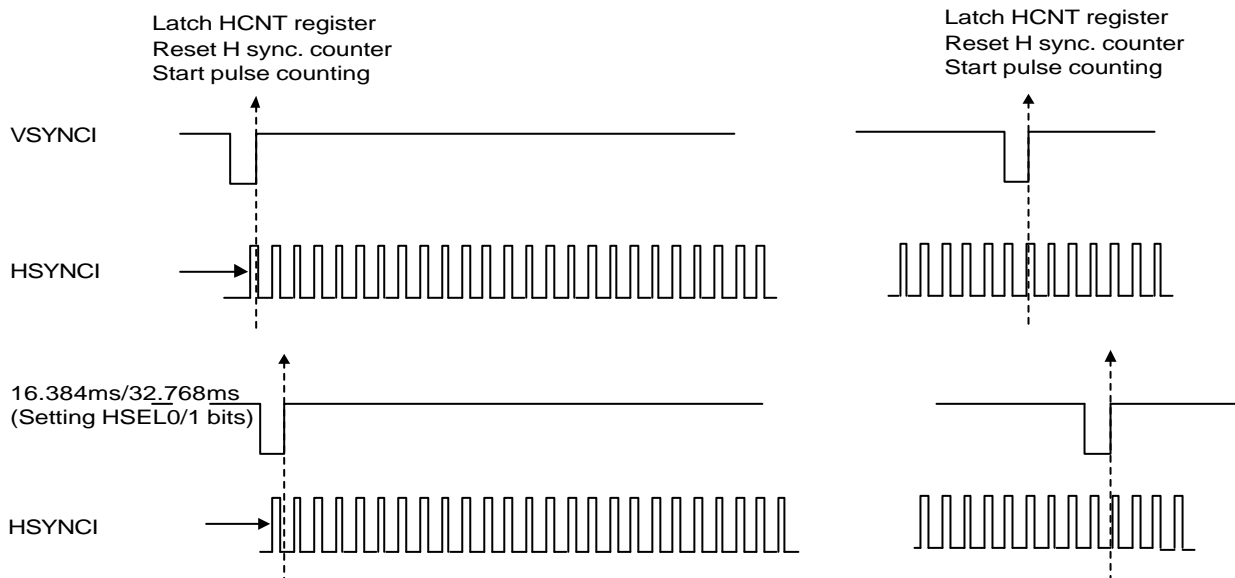

Figure 13.4. Hsync Counter Operation

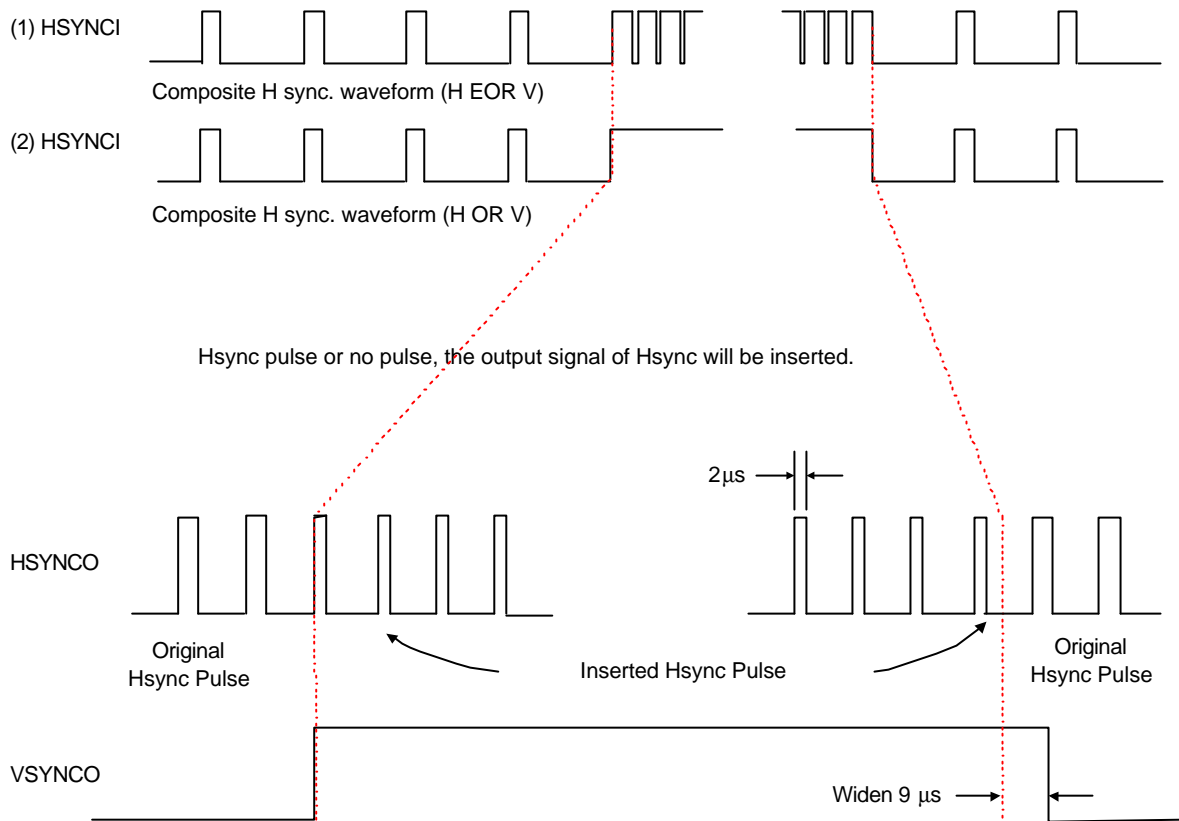

Figure 13.5. Composite H & V Sync. Processing

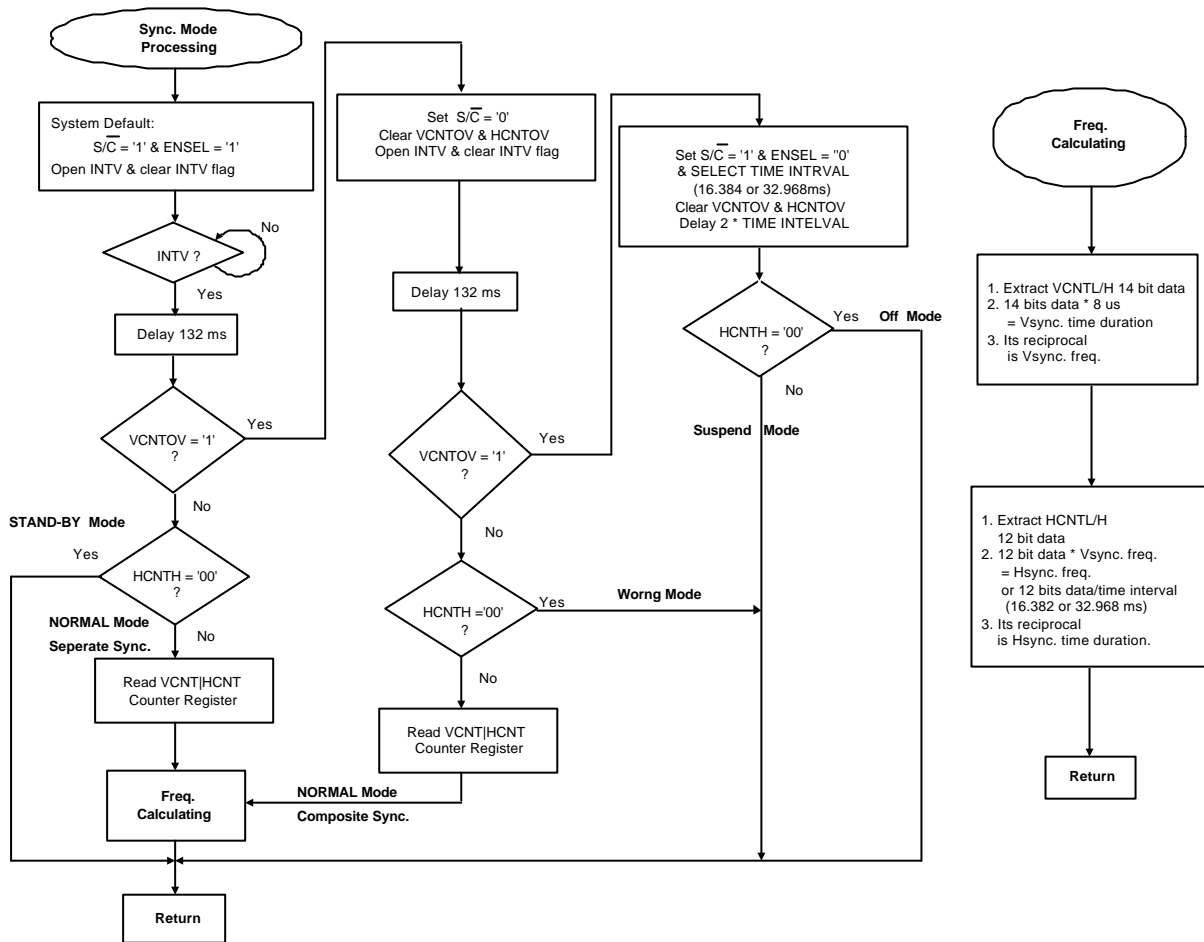

Figure 13.6. H & V Sync. Software Control Flow Chart (for reference only)

13.2. Sync Processor Control Register:

Polarity: The detection of Hsync or Vsync polarity is achieved by hardware circuit that samples the sync signal's voltage level periodically. Users can read HPOLI & VPOLI bit from HVCON register, which bit = '1' represents positive polarity and '0' represents negative polarity. Furthermore, users can read HSYNCI and VSYNCI bit in HVCON register to detect H & V sync input signal. Users can control the polarity of H & V sync output signal by writing the appropriate data to the HPOLO and VPOLO bits in the HVCON register, '1' represents positive polarity and '0', negative polarity.

Composite sync: Users have to determine whether the incoming signal is separate sync or composite sync and set $\overline{S/C}$ & $\overline{ENHSEL}/\overline{HSEL}$ bit properly. If the input sync signal is composite, after set $\overline{S/C}$ to '0', the sync separator block will be activated (please refer Figure 13.5). At the area of Vsync pulse, there can exist Hsync pulses or not. For the output of Hsync, users can active hardware to interpolate the Hsync pulses in that area by clearing the \overline{INSEN} bit. The width of these inserted pulses is 2 μ S fixed and the time interval is the same as previous one. According to the last Hsync pulse outside the Vsync pulse duration, the hardware will arrange the interval of these hardware interpolated pulses. These inserted Hsync pulse have 125 nS phase deviation maximum. The Vsync pulse can be extracted by hardware from composite Hsync signal, and the delay time of output Vsync signal will be limited below 20ns. For inserting Hsync pulse safely, the extracted Vsync pulse will be widens about 9 μ s. Because evenly inserting the Hsync pulse, the last inserted Hsync pulse will have different frequency from original ones. System will not implement this insertion function, users must clear \overline{INSEN} bit in the SYNCON control register to activate this function. After reset, $\overline{S/C}$ & \overline{INSEN} bits default value is HIGH and clear the VCNT | HCNT counter latches to zero.

Sync output: In pin assignment, VSYNCO & HSYNCO represent Vsync & Hsync output which are shared with P06 & P07 respectively. If \overline{ENVOUT} & \overline{ENHOUT} is set to '0' in HVCON register, P06 & P07 will act as VSYNCO & HSYNCO output pins. When the input sync is separate signal, the V/HSYNCO will output the same signal as input without delay. But if the input sync is composite signal, the VSYNCO signal will have fixed delay time about 20ns and the HSYNCO has nonfixed delay time about 125ns.

Half frequency Input and output: In pin assignment, when users set \overline{ENHALF} bits to '0' in HALFCON register, the HALFHO pin will act as output pin and output half of input signal in the HALFHI pin with 50% duty (see Figure 13.7). If set \overline{NOHALF} to '0', HALFHO will output the same signal in the HALFHI pin and user can control its polarity of output HALFHO by setting HALFPOLO bit, '1' for positive and '0' for negative polarity. After the chip is reset, \overline{ENHALF} , \overline{NOHALF} & HALFPOLO will be in the HIGH state and P12 & P13 will act as I/O pins. It is recommended to add a Schmitt Trigger buffer at front of the HALFHI pin.

Free run signal output: User can select one of free running frequency (list below) outputting to HSYNCO & VSYNCO pin by setting the $\overline{FREQ0}/\overline{1/2}$ bits. If user does not enable H/VSYNCO by clearing \overline{ENVOUT} or \overline{ENHOUT} bits, any setting of $\overline{FREQ0}/\overline{1/2}$ bits will be invalid. After system reset, NT6862 does not provide free running frequency and both of $\overline{FREQ0}/\overline{1/2}$ bits are set to '1'. The free running frequency can be set according the table below:

Free Running Freq.	$\overline{FREQ2}$	$\overline{FREQ1}$	$\overline{FREQ0}$	Hsync Freq.	Vsync Freq.	Note
1	0	0	0	8M/256=31.2K	Hsync/512=61.0Hz	Refer to Figure 13.7
2	0	0	1	8M/4/9/5=44.4K	Hsync/512=86.8Hz	
3	0	1	0	8M/128=62.5K	Hsync/3/5/7/8=74.4Hz	
4	0	1	1	8M/4/5/5=80K	Hsync/1024=78.1Hz	
5	1	0	0/1	8M/4/2/11=90.9K	Hsync/1024=88.7Hz	
	1	1	0			
	1	1	1	Disabled Free Run function		After System Reset

Self testing pattern: At activating free running function, the system will generate the testing pattern when clearing the $\overline{\text{ENPAT}}$ bit. The PORT14 pin will switch from I/O pin to pattern output pin (push-pull structure). The system provides four types of testing patterns. Refer the figure below. Set the $\overline{\text{PAT0}}$ bits to select the pattern type (Figure 13.8). If the free run function has not been enabled, any change of $\overline{\text{ENPAT}}$ & $\overline{\text{PAT0}}$ bits will be invalid. Refer the Figure 13.9 for the porch time of video pattern.

$\overline{\text{PAT0}}$	Test Pattern	Note
0	(1)	Only activated on $\overline{\text{ENPAT}}$ bit be cleared
1	(2)	

The porch of self test pattern are listed below:

Free Running Freq.	Front Porch of VBLANK	BACK Porch of VBLANK	Front Porch of HBLANK	BACK Porch of HBLANK	VSYNC PULSE WIDTH	HSYNC PULSE WIDTH
1	128 μs	864 μs	460ns	2.00 μs	64 μs	1 μs
2	90.5 μs	589 μs	1.18 μs	1.93 μs	64 μs	1 μs
3	51 μs	528 μs	424ns	1.92 μs	64 μs	1 μs
4	51.5 μs	596 μs	185ns	1.94 μs	64 μs	1 μs
5	46.6 μs	515 μs	436ns	1.94 μs	64 μs	1 μs

Mode change detection: The system provides a hardware detection of Sync signal changed and support user to respond to this transition an proper process as soon as possible. There are three kinds of detections to set INTMUTE bit.

Hsync counter: Users can enable HDIFF comparison by clearing $\overline{\text{ENHDIFF}}$ bit and then preload an difference value to HDIFF0-3 bits in the AUTOMUTE control register (\$000E). The system will latch the new value of Hsync counter and compare it with the last latched value. If this difference is great than this user defined value at HDIFF0-3 bits, system will set the INTMUTE interrupt bit.

H/V polarity: Users can enable polarity detection by clearing $\overline{\text{ENPOL}}$ bit. The system will set the INTMUTE bit when the polarity of Hsync or Vsync have been changed.

H/V counter overflow: Users can enable the detection of sync counters overflow by clearing $\overline{\text{ENOVER}}$ bit. The system will set the INTMUTE bit whenever the counter of Hsync or Vsync has been overflowed.

The above three sources of setting this INTMUTE bit can be enabled or disabled by user. If user opens this interrupt, the system will generate an NMI interrupt to remind users anytime. At user's manipulation, a software debounce to confirm the transition of sync signal for one more times will make this system stable and reliable, but it will affect the response time. After system reset, this 'automute' function will be disabled and the HDIFF0-2 control bits will be cleared to '\$0F'.

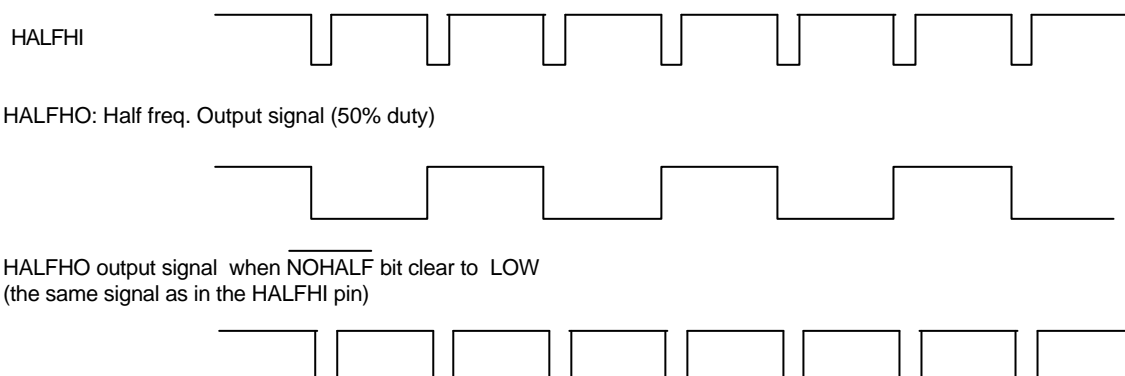

Figure 13.7. Half Freq. Sync. Waveform

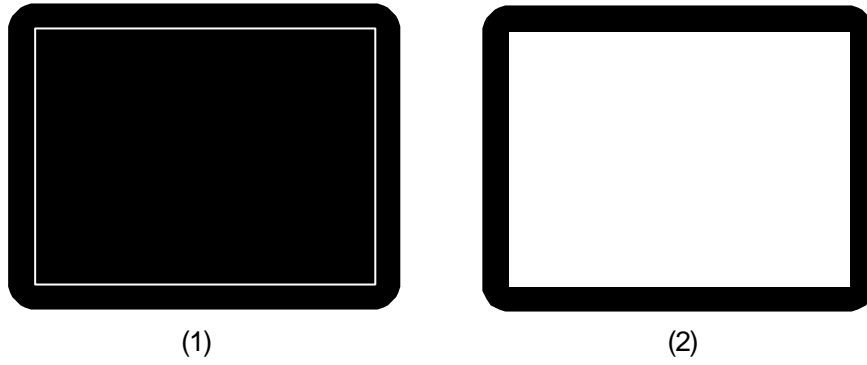

Figure 13.8. Two Types of Testing Pattern

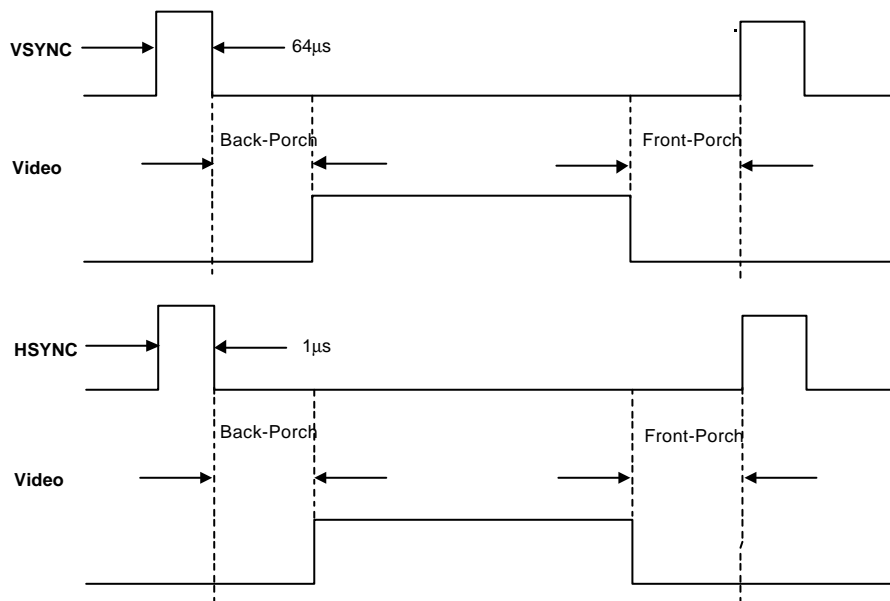

Figure 13.9. The Porch of Free Running Self Test Pattern

13.3 Power Saving Mode detect:

Video mode is listed as below, especially from mode 2 to mode 4 just for power saving. All of modes can be detected by NT6862 (Figure 13.6). These modes can be easily be detected.

Mode	H-Sync	V-Sync
(1) Normal	Active	Active
(2) Stand-by	Inactive	Active
(3) Suspend	Active	Inactive
(4) Off	Inactive	Inactive

Control Bit Description:

Addr.	Register	INIT	Bit7	Bit6	Bit5	Bit4	Bit3	Bit2	Bit1	Bit0	R/W
Control Registers for Synprocessor											
\$0006	SYNCON	FFH	-	-	-	-	$\overline{\text{INSEN}}$	-	$\overline{\text{HSEL}}$	S/ $\overline{\text{C}}$	R
		FFH	-	-	-	-	$\overline{\text{INSEN}}$	$\overline{\text{ENHSEL}}$	$\overline{\text{HSEL}}$	S/ $\overline{\text{C}}$	W
\$0007	HV CON	FFH	-	-	HSYNCI	VSYNCI	HPOLI	VPOLI	HPOLO	VPOLO	R
		FFH	$\overline{\text{ENHOUT}}$	$\overline{\text{ENVOUT}}$	-	-	-	-	HPOLO	VPOLO	W
\$0008	HCNT L	00H	HCL7	HCL6	HCL5	HCL4	HCL3	HCL2	HCL1	HCL0	R
\$0009	HCNT H	00H	HCNTOV	-	-	-	HCH3	HCH2	HCH1	HCH0	R
			CLRHOV	-	-	-	-	-	-	-	W
\$000A	VCNT L	00H	VCL7	VCL6	VCL5	VCL4	VCL3	VCL2	VCL1	VCL0	R
\$000B	VCNT H	00H	VCNTOV	-	VCH5	VCH4	VCH3	VCH2	VCH1	VCH0	R
			CLRVOV	-	-	-	-	-	-	-	W
\$000C	FREECON	FFH	$\overline{\text{ENPAT}}$	$\overline{\text{PAT0}}$	-	-	-	$\overline{\text{FREQ2}}$	$\overline{\text{FREQ1}}$	$\overline{\text{FREQ0}}$	W
\$000D	HALFCON	FFH	$\overline{\text{ENHALF}}$	$\overline{\text{NOHALF}}$	HALFPOL	-	-	-	-	-	W
\$000E	AUTOMUTE	FFH	$\overline{\text{ENHDIFF}}$	$\overline{\text{ENPOL}}$	$\overline{\text{ENOVER}}$	-	HDIFFVL3	HDIFFVL2	HDIFFVL1	HDIFFVL0	W

14. Base Timer (BT)

The BASE TIMER is an 8-bit counter, and its clock source can be chosen with 1 μ s or 1ms by setting the BTCLK bit ('0' for 1 μ s and '1' for 1ms). The BT can be enabled or disabled by the $\overline{\text{ENBT}}$ bit in the BTCON register. The BT will start counting while clearing the $\overline{\text{ENBT}}$ bit to '0'. After the chip is reset, the BTCLK and $\overline{\text{ENBT}}$ bits are set to '1' (the BT is disabled). Before enabling the BT, it can be preloaded with

a value by writing a value to the BT register (write only) at any time and then the BT will start to count up from this preloaded value. When the BT's value reaches FFH, it will generate a timer interrupt if the timer interrupt is enabled, and then the counter will wrap around to 00H. The timer's maximum interval is 256ms or 256 μ s depending on the BTCLK value.

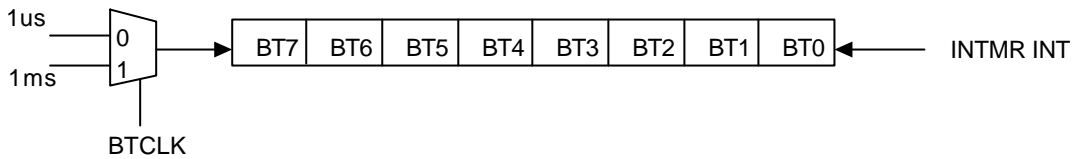

Control Bit Description:

Addr.	Register	INIT	Bit7	Bit6	Bit5	Bit4	Bit3	Bit2	Bit1	Bit0	R/W
\$002E	BT	00H	BT7	BT6	BT5	BT4	BT3	BT2	BT1	BT0	W
\$002F	BT CON	03H	-	-	-	-	-	-	$\overline{\text{BTCLK}}$	$\overline{\text{ENBT}}$	W

15. I²C Bus Interface: DDC1 & DDC2B Slave Mode

Interface: I²C bus interface is a two-wire, bi-directional serial bus which provides a simple, efficient way for data communication between devices, and minimizes the cost of connecting among various peripheral devices. NT6862 provides two I²C channels. Both of them are shared with I/O pins and their structures are open drain. When the system is reset, these channels are originally general I/O pins structure. All of these I²C bus function will be activated only after their $\overline{\text{ENDDC}}$ bits are cleared to '0' (CH0/1CON registers).

DDC1 & DDC2B+ function: Two modes of operation have been implemented in NT6862, uni-directional mode (DDC1 mode) and bi-directional mode (DDC2B+ mode). These channels will be activated as DDC1 function initially when users enable DDC function. These channels will switch automatically to DDC2B+ function from DDC1 function when a low pulse greater than 500ns is detected on the SCL line. Users can start a master communication directly from DDC1 communication by clearing $\overline{\text{MODE}}$ bit in the CH0/1CLK control register.

The channels can return to DDC1 function when users set the MD1/ $\overline{2}$ bit to '1' in the CH0/1CON registers.

15.1. DDC1 bus interface

Vsync input and SDA pin: In DDC1 function, the Vsync pin is used as input clock pin and SDA pin is used as data output pin. This function comprises two data buffers: one is preloading data buffer for putting one byte data in advance by user (CH0/1TXDAT), and the other is shift register for shifting out one bit data to SDA line, which users can not access directly. These two data buffer cooperate properly.

For the timing diagram please refer to Figure 15.1. After system resets, the I²C bus interface is in DDC1 mode.

Data transfer: At first, user must put one byte transmitted data into CH0/1TXDAT register in advance, and activate I²C bus by setting $\overline{\text{ENDDC}}$ bit to '0'. Then open INTTX0/1 interrupt source by setting INTTX0/1 to '1' in the IEIRQ0/1 registers. On the first 9 rising edges of Vsync, system will shift out invalid bit in shift register to SDA pin to empty shift register. When shift register is empty and on next rising edge of Vsync, it will load data in the CH0/1TXDAT registers to internal shift register. At the same time, NT6862 will shift out MSB bit and generate an INTTX0/1 interrupts to remind user to put next byte data into CH0/1TXDAT register. After eight rising clocks, there have been eight bits shifted out in proper order and shift register becomes empty again. At the ninth rising clock, it will shift the ninth bit (null bit '1') out to SDA. And on the next rising edge of Vsync clock, system will generate an INTTX0/1 interrupts again. By the same way, NT6862 will load new data from CH0/1TXDAT registers to internal shift register and shift out one bit right away. Beware that user should put one new data into CH0/1TXDAT registers properly before the shift register is empty (the next INTTX0/1 interrupt). If not, the hardware will transmit the last byte data repeatedly.

Vsync clock: Only in the separate SYNC mode, can the Vsync pulse be used as data transfer clock, its frequency can be up to 25KHz maximum. In composite Vsync mode, NT6862 can not transmit any data to SDA pin, regardless whether the Vsync can be extracted from composite Hsync signal.

Control Bit Description:

Addr.	Register	INIT	Bit7	Bit6	Bit5	Bit4	Bit3	Bit2	Bit1	Bit0	R/W
\$0016	NMIPOLL	00H	-	-	-	-	-	-	INTE0	INTMUTE	R
			-	-	-	-	-	-	CLRE0	CLRMUTE	W
\$0017	IRQPOLL	00H	-	-	-	-	-	IRQ2	IRQ1	IRQ0	R
\$0019	IEIRQ0	00H	-	-	INTS0	INTA0	INTTX0	INTRX0	INTNAK0	INTSTOP0	RW
\$001A	IEIRQ1	00H	-	-	INTS1	INTA1	INTTX1	INTRX1	INTNAK1	INTSTOP1	RW
\$001C	IRQ0	00H	-	-	INTS0	INTA0	INTTX0	INTRX0	INTNAK0	INTSTOP0	R
			-	-	CLRS0	CLRA0	CLRTX0	CLRRX0	CLRNAK0	CLRSTOP0	W
\$001D	IRQ1	00H	-	-	INTS1	INTA1	INTTX1	INTRX1	INTNAK1	INTSTOP1	R
			-	-	CLRS1	CLRA1	CLRTX1	CLRRX1	CLRNAK1	CLRSTOP1	W
Control Register for DDC1/2B+ of Channel 0											
\$0021	CH0ADDR	A0H	ADR7	ADR6	ADR5	ADR4	ADR3	ADR2	ADR1	-	W
\$0022	CH0TXDAT	00H	TX7	TX6	TX5	TX4	TX3	TX2	TX1	TX0	W
\$0023	CH0RXDAT	00H	RX7	RX6	RX5	RX4	RX3	RX2	RX1	RX0	R
\$0024	CH0CON	E0H	$\overline{\text{ENDDC}}$	$\text{MD1}/\overline{2}$	-	START	STOP	-	TXACK	-	W
			-	-	$\overline{\text{SRW}}$	START	STOP	RXACK	-	-	R
\$0025	CH0CLK	FFH	$\overline{\text{MODE}}$	$\overline{\text{MRW}}$	$\overline{\text{RSTART}}$	-	-	DDC2BR2	DDC2BR1	DDC2BR0	W
Control Register for DDC1/2B+ of Channel 1											
\$0026	CH1ADDR	A0H	ADR7	ADR6	ADR5	ADR4	ADR3	ADR2	ADR1	-	W
\$0027	CH1TXDAT	00H	TX7	TX6	TX5	TX4	TX3	TX2	TX1	TX0	W
\$0028	CH1RXDAT	00H	RX7	RX6	RX5	RX4	RX3	RX2	RX1	RX0	R
\$0029	CH1CON	E0H	$\overline{\text{ENDDC}}$	$\text{MD1}/\overline{2}$	-	START	STOP	-	TXACK	-	W
			-	-	$\overline{\text{SRW}}$	START	STOP	RXACK	-	-	R
\$002A	CH1CLK	FFH	$\overline{\text{MODE}}$	$\overline{\text{MRW}}$	$\overline{\text{RSTART}}$	-	-	DDC2BR2	DDC2BR1	DDC2BR0	W

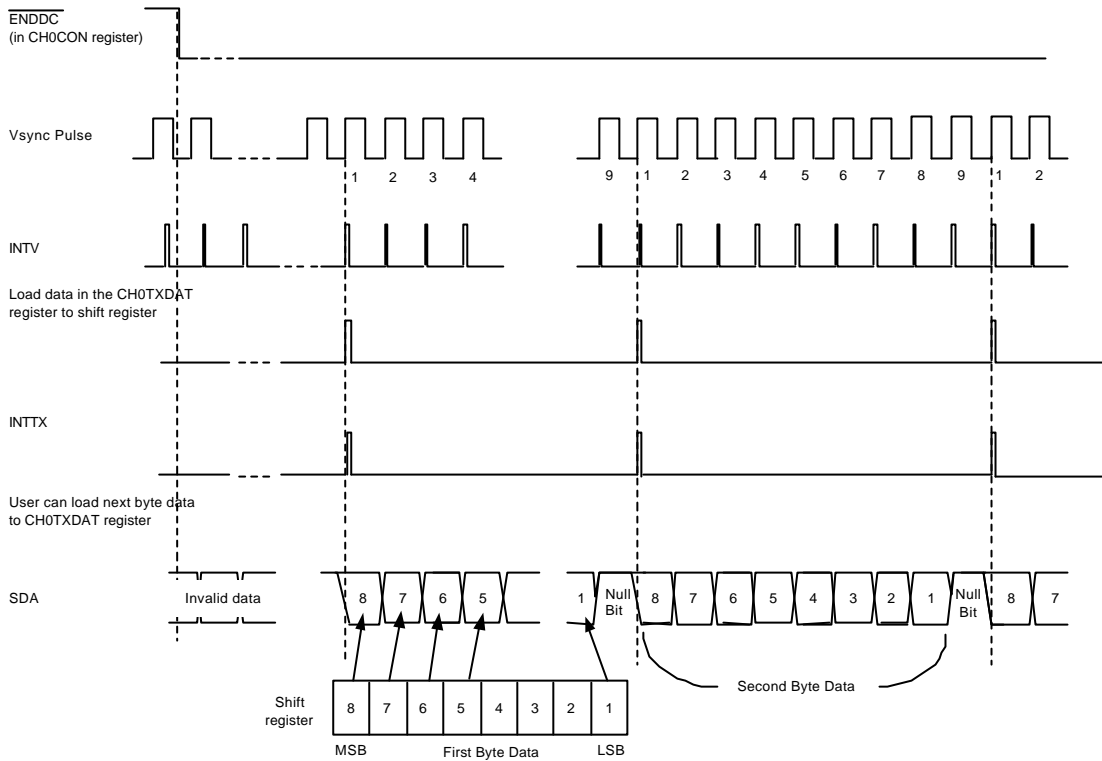

Figure 15.1. DDC1 Mode Timing Diagram

15.2. DDC2B + Slave & Master Mode Bus Interface

The built-in DDC2B+ I²C bus Interface features as follows :

- SLAVE mode (NT6862 is addressed by a master which drives SCL signal)
- MASTER mode (NT6862 addresses external device and send out SCL clock)
- Compatible with I²C bus standard
- One default address (A0H) and one programable address
- Automatic wait state insertion
- Interrupt generation for status control
- Detection of START and STOP signals

The DDC2B+ will be activated as SLAVE mode initially.

Users can switch to MASTER mode by clearing the MODE bit under either of these conditions listed as follows:

1. After entering to DDC1 function and clearing this bit, the system will be changed from DDC1 to DDC2B+ MASTER mode operation.
2. After entering to DDC2B+ slave mode function and clearing this bit, the system will be changed from slave mode into master mode operation.

As clearing MODE bit, system will send out a 'START' condition and wait for user to put the calling address into CH0/1TXDAT control register. Notice that user must predetermine the direction of master mode transmission before putting calling address.

Below is the DDC2B+ function with channel 0, and the manipulation of channel 1 is the same as channel 0.

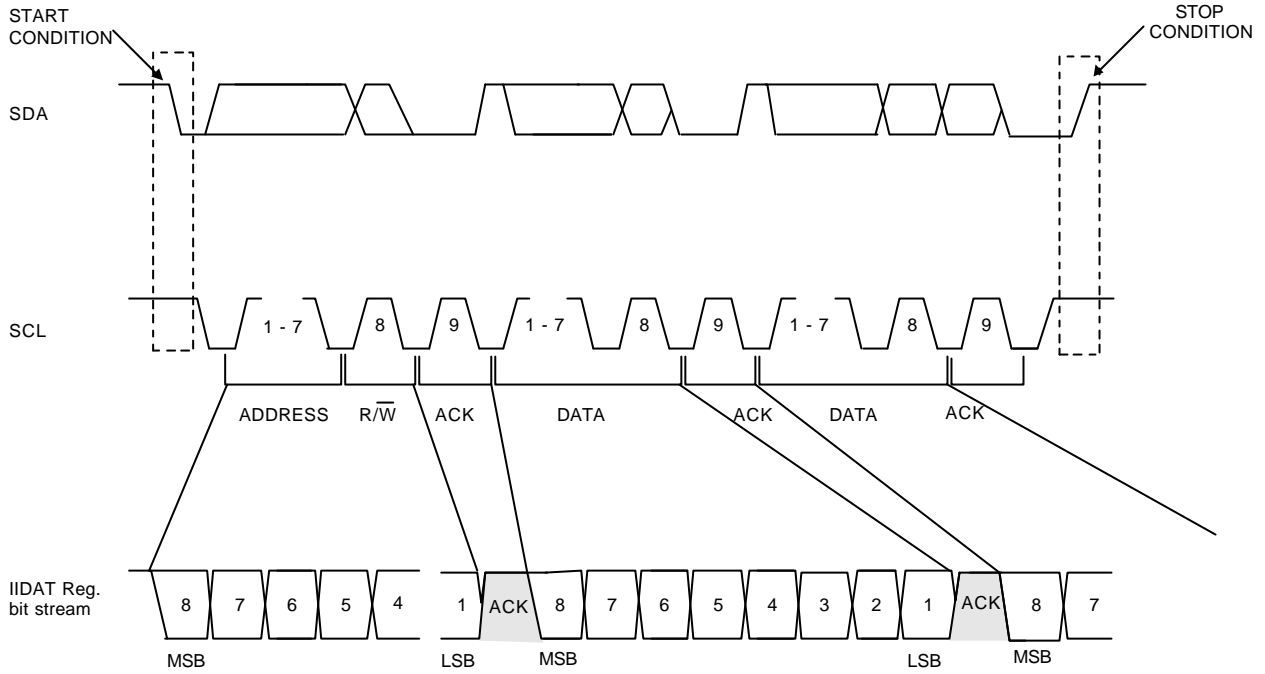
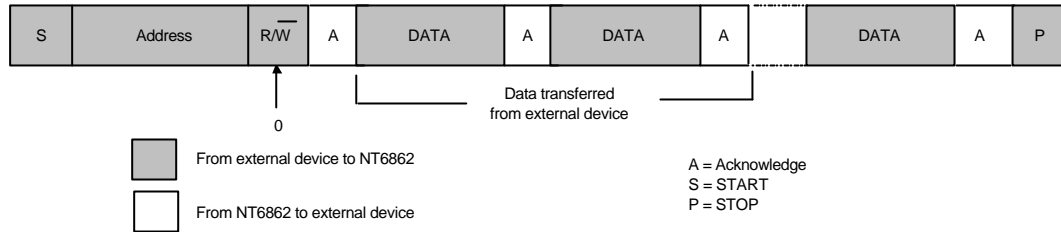
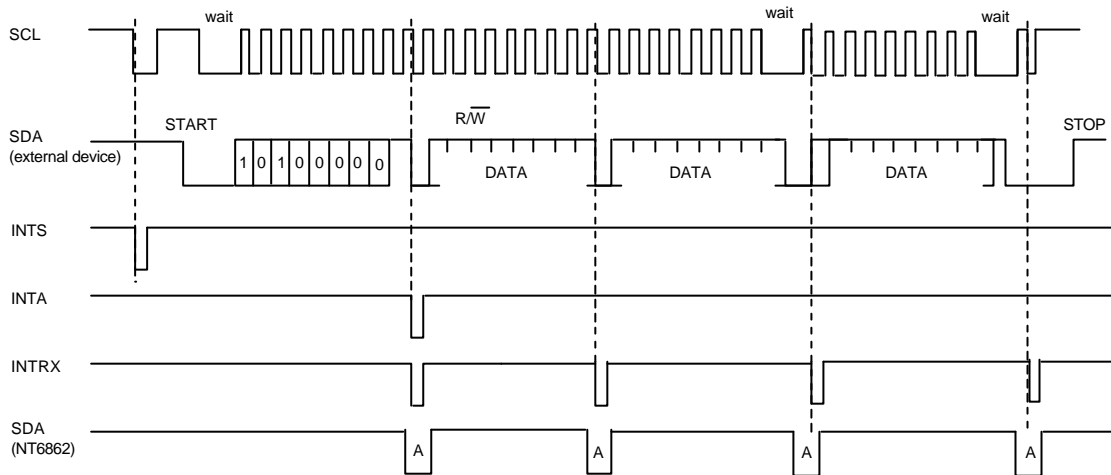

Figure 15.2. DDC2B Data Transfer



(a) WRITE Mode Data Format



(b) WRITE Mode Timing Diagram

Figure 15.3. DDC2B Write Mode Spec.

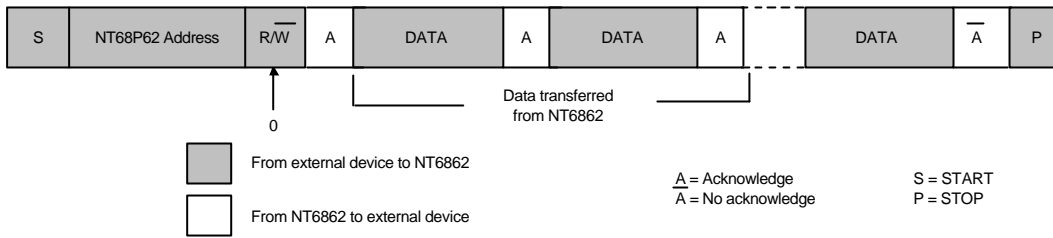

(a) Read Mode Data Format

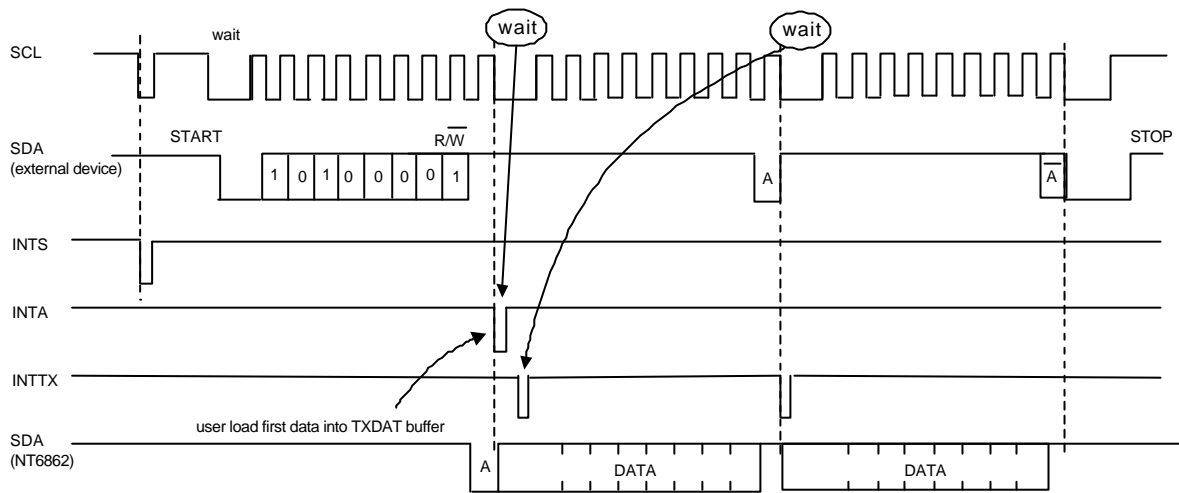

(b) READ Mode Timing Diagram

Figure 15.4. DDC2B Read Mode Spec.

15.3. DDC2B Slave Mode Bus Interface

Enable I²C and INTS: After user clears the $\overline{\text{ENDDC}}$ to '0', NT6862 will enter into DDC1 mode, and it will switch to DDC2B SLAVE mode while a low pulse is detected on SCL line. The DDC2B bus consists of two wires, SCL and SDA; SCL is the data transmission clock and SDA is the data line. NT6862 will remind user that the mode has changed by generating a INTS interrupt. When users set $\text{MD1}/\overline{2}$ to '1' at this time, the NT6862 will return back to DDC1 mode. (For DDC2B please refer to Figure 15.2.) The figure exhibits what are important in I²C: START signal, slave ADDRESS, transferred data (proceed byte by byte) and a STOP signal.

Start condition: When SCL & SDA lines are at HIGH state, an external device (master) may initiate communication by sending a START signal (defined as SDA from high to low transition while SCL is at high state). When there is a START condition, NT6862 will set the 'START' bit to '1' and user can poll this status bit to control DDC2B transmission at any time. This bit will keep '1' until user clears it. After sending a START signal for DDC2B communication, an external device can repeatedly send start condition without sending a STOP signal to terminate this communication. This is used by external device to communicate with another slave or with the same slave in different mode (Read or Write mode) without releasing the bus.

Address matched and INTA0: After the START condition, a slave address is sent by an external device. When I²C bus interface changes to DDC2B mode, NT6862 will act as a receiver first to receive this one byte data. This address data is 7 bits long followed by the eighth bit (R/W) that indicates data transfer direction. When the NT6862 system

receives an address data from an external device, it will store it in the CH0RXDAT register. The system supports 'A0' default address and another one set of addresses which can be accessed by writing the CH0ADDR register. Upon receiving the calling address from an external device, the system will compare this received data with the default 'A0' address and data in the CH0ADDR register. Either of these address matched, the system will set the INTA0 bit in the IRQ0 register. If the user sets INTA0 bit to '1' (in IEIRQ0 register) in advanced and addresses match, the NT6862 will generate a INTA0 interrupt. Under the address matching condition, the NT6862 will send an acknowledge bit to an external device. If address does not match, the NT6862 will not generate INTA0 interrupt and neglect the data change on SDA line in the future.

Data transmission direction: In INTA0 interrupt servicing routine, user must check the LSB of address data in CH0RXDAT register. According to I²C bus protocol, this bit indicates the DDC2B data transfer direction in later transmission; '1' indicates a request for 'READ MODE' action (external master device read data from system), '0' indicates a 'WRITE MODE' action (external master device write data to system). The timing about READ mode and WRITE mode please refer to Figure 15.3 and Figure 15.4. The data transfer can proceed byte by byte in a direction specified by the $\text{R}/\overline{\text{W}}$ bit after a successful slave address is received.

The system will switch to either 'READ' mode or 'WRITE' mode automatically which is determined by this direction bit.

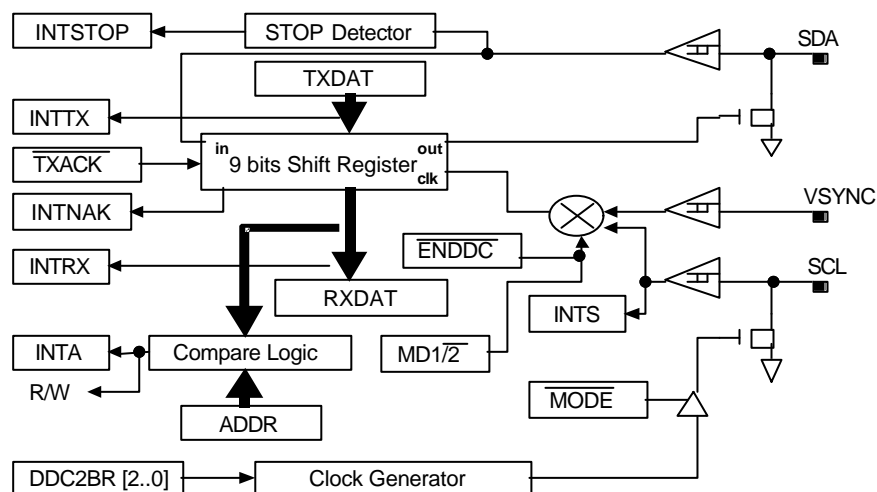

Figure 15.5. DDC Structure Block

Data transfer and wait: The data on the SDA line must be stable during the HIGH period of the clock on the SCL line. The HIGH and LOW state of the SDA line can only change when the clock signal on the SCL line is LOW. Each byte data is eight bits long and one clock pulse for one bit of data transfer. Data is transferred with the most significant bit (MSB) first. In the wired-AND connection, any slower device can hold the SCL line LOW to force the faster device into a wait state. Data transmission will be suspended until the slower device is ready for the next byte transfer by releasing the SCL line.

Acknowledge: The acknowledgment will be generated at ninth clock by whom receiving data. In the WRITE MODE, NT6862 system must respond to this acknowledgment.

Users should clear the $\overline{\text{TXACK}}$ bit in the CH0CON to open the 'ACK' function. After receiving one byte data from external device, NT6862 will automatically send this acknowledgment bit.

In the READ mode, an external device must respond to the acknowledgment bit after every byte data is sent out. The system will set the INTNAK bit when external device does not send out the '0' acknowledgment bit. Furthermore, user can open this interrupt source by clearing the INTNAK bit in the IEIRQ0 register.

The INTTX0 & INTRX0 interrupt: After NT6862 complete one byte transmission or receiving, it will generate an INTTX0 (READ mode) & INTRX0 (WRITE mode) interrupts. These interrupts are generated at the falling edge of the ninth clock. Users can control the flow of DDC2B transmission at these interrupts.

The INTRX0 on the WRITE mode: NT6862 read data from external master device. When users detect an INTRX0 interrupt, it means there has one byte data received and user can read out by accessing CH0RXDAT control register. At the same time, if user responded an 'ACK' signal beforehand, the shift register will send out this 'ACK' bit (low voltage) and continue to receive the next byte data. If both of shift register and CH0RXDAT register are full and user still did not load data from CH0RXDAT register, the SCL will be held LOW and waiting for NT6862. After user obtains one byte data from CH0RXDAT register, the SCL will be released for generation of SCL transmission clock. External device can continue sending next byte data to NT6862. The timing diagram refers to Figure 15.3. User must responde a NAK signal in advance to stop the transmission.

The INTTX0 on the READ mode: External device read data from NT6862. At INTTX0 interrupt, the system will load new data from CH0TXDAT register which has been put by user beforehand into internal shift register and continue sending out this new data. After this new loading data be shifted out according every SCL clock, system will request user to put next byte data into CH0TXDAT register.

If both of shift register and CH0TXDAT register are empty and user still not load data to CH0TXDAT register, the SCL will be held LOW and waiting by NT6862 after receiving the acknowledgment bit.

At SCL holded low by system, after user has put one new byte data into CH0TXDAT register, the SCL will be released for generation of SCL transmission clock. At this time, system will load this byte data into shift register and generate a INTTX0 interrupt again to remind user putting next byte into CH0TXDAT register. The timing diagram refer to Figure 15.4.

After every one byte data transfer, system will monitor if external master device has sent out this acknowledgment bit or not. If not, system will set the INTNAK bit (the acknowledgment is LOW signal). Users will get a INTNAK interrupt if INTNAK has been enabled as a interrupt source.

STOP condition: When SCL & SDA line have been released (hold on 'high' state), DDC2B data transfer is always terminated by a STOP condition generated by external device. A STOP signal is defined as a LOW to HIGH transition of SDA while SCL is at HIGH state. When there is a STOP condition, NT6862 will set the 'STOP' bit & INTSTOP bit to '1' and user can poll this status bit or open a INTSTOP interrupt to control DDC2B transmission at any time. This bit will keep '1' until user clears it by writing '1' to this bit. Notice the SCL and SDA lines must conform to I²C bus specifications. For the software flowchart can please refer Figure 15.6. Please refer to the standard I²C bus specification for details.

Change to DDC1 mode: After an external device terminates DDC2 transmission by sending a STOP condition, users can set MD1/ $\overline{2}$ to '1' for changing to DDC1 mode. On the other hand, when the SCL line has been released (pulled-up), user can force NT6862 to DDC1 mode communication at any time.

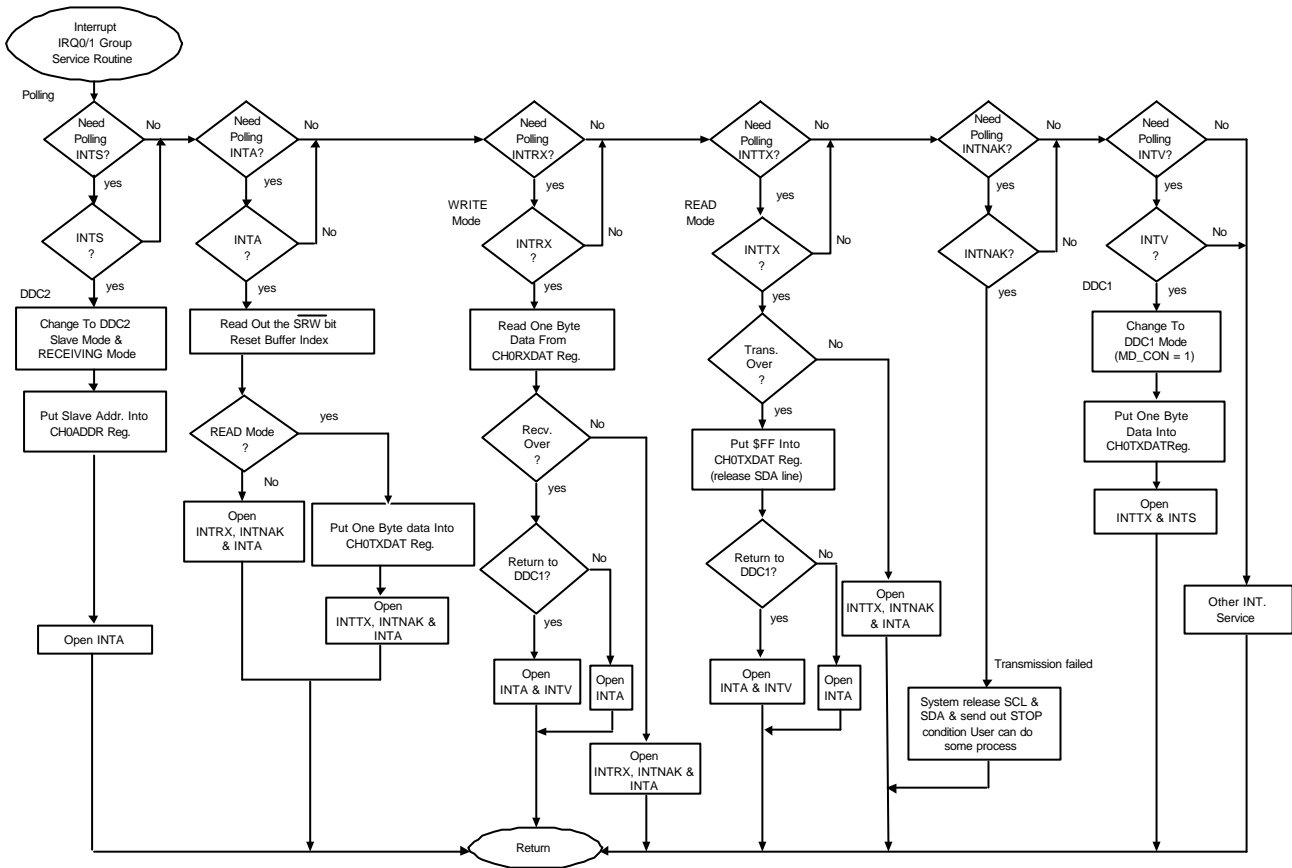

SLAVE Mode Operation

Figure 15.6. Slave Mode INT Operation

15.4 DDC2B+ Master Mode Bus Interface

Most of the DDC manipulation is the same as SLAVE mode except the SCL clock generation. In the MASTER mode, the control of SCL clock source belongs to NT6862. Users must set the calling address and transmission direction in advance. Access the \overline{MODE} & \overline{MRW} bits to control the transmission flow of DDC2B+ master mode communication.

Start condition: After user clearing \overline{ENDDC} & \overline{MODE} bit, the system will generate a 'START' condition on the SCL & SDA lines and wait for user to put the calling address into TXDAT buffer and send to SDA line. The frequency of SCL is dependant on the baud-rate setting value (DDCBR0 - DDCBR2) in register CH0CLK. And the data transmission direction will be dependant on the \overline{MRW} bit and the LSB of calling address, '1' for read operation and '0' for write operation.

Calling address: Calling address is 8 bits long. It should be put in the CH0TXDAT. The setting of LSB bit in this TXDAT buffer should be as same as \overline{MRW} bit.

STOP condition: There are several cases that the system will send out 'STOP' condition on the SCL & SDA lines. First, in the 'READ' operation, if user sets TXACK bit to '1', the system will send out 'NAK' condition on the bus after receiving one byte data and then send out 'STOP' condition automatically later. Second, in the 'START' condition and after sending out calling address, if no slave has respond to a 'ACK' signal, the master will send out 'STOP' condition automatically. Third, if user sets \overline{MODE} bit to '1', the system will generate a 'STOP' condition after the current byte transmission is done. Notice that if slave device did not released SCL and SDA line, the system can not send out 'STOP' condition.

After 'STOP' condition, the master will release SCL & SDA lines and return to SLAVE mode.

The INTTX0 & INTRX0 interrupt: After NT6862 completing one byte transmission or receiving, it will generate an INTTX0 (WRITE mode) & INTRX0 (READ mode) interrupts. Users can control the flow of DDC2B transmission at these interrupts.

The INTRX0 on the read mode: NT6862 reads data from external slave device. When users detect a INTRX0 interrupt, it means there is one byte data received and user can read out by accessing CH0RXDAT control register. At the same time, if the user responded an 'ACK' signal

beforehand, the shift register will send out an 'ACK' bit (low voltage) and continue to receive next byte data. If both the shift register and CH0RXDAT register are full and user still did not load data from CH0RXDAT register, the SCL will be held LOW and wait for NT6862. After user has received one byte data from CH0RXDAT register, the SCL will be released for generation of SCL transmission clock. An external device can continue sending next byte data to NT6862. Refer Figure 15.7 for the timing diagram. User must respond to a NAK signal in advance to stop the transmission. Before the last two bytes of data is received, user should respond an 'NAK' signal. Then, system will send out 'NAK' bit after receiving the last byte data and 'STOP' condition to notify the slave terminated current transmission.

The INTTX0 on the WRITE mode: External device read data from NT6862. At INTTX0 interrupt, the system will load new data from CH0TXDAT register which has been put by user beforehand into internal shift register and continue sending out this new data. After this new loading data be shifted out according every SCL clock, system will request user to put next byte data into CH0TXDAT register.

If both of shift register and CH0TXDAT register are empty and user still not load data to CH0TXDAT register, the SCL will be held LOW and wait for NT6862 after receiving the acknowledgment bit.

If SCL is held low by system, and user has put one new byte data into CH0TXDAT register, the SCL will be released for generation of SCL transmission clock. At this time, system will load this byte data into shift register and generate an INTTX0 interrupt again to remind user putting next byte into CH0TXDAT register. Refer to Figure 15.8 for the timing diagram.

Repeat start condition: If clearing the \overline{RSTART} bit to '0' in the 'WRITE' operation, system will send out a REPEAT START'. Notice that if slave device did not release SCL and SDA line, the system can not send out 'REPEAT START' condition.

SCL baud rate selection: There are three Baud Rate bits for user to select one of eight clock rates on the SCL line. After system reset, the default value of these Baud Rate bits (DDC2BR0-2) are '111'.

DDC2BR2	DDC2BR1	DDC2BR0	Baud Rate
0.00	0.00	0.00	400K
0.00	0.00	1.00	200K
0.00	1.00	0.00	100K
0.00	1.00	1.00	50K
1.00	0.00	0.00	25K
1.00	0.00	1.00	12.5K
1.00	1.00	0.00	6.25K
1.00	1.00	1.00	3.125K

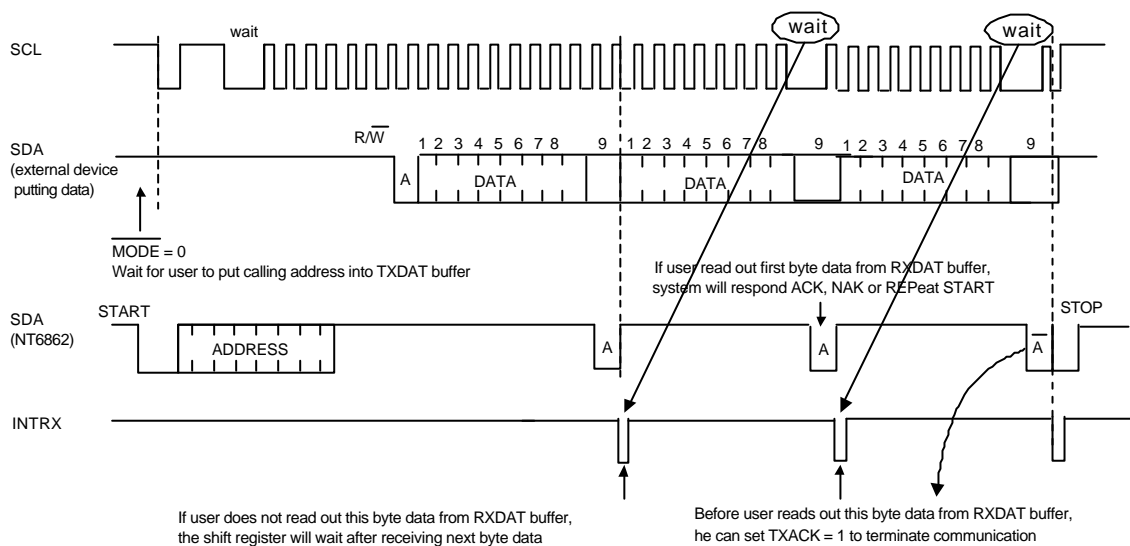
Figure 15.7. DDC2B+ MASTER READ Mode Timing

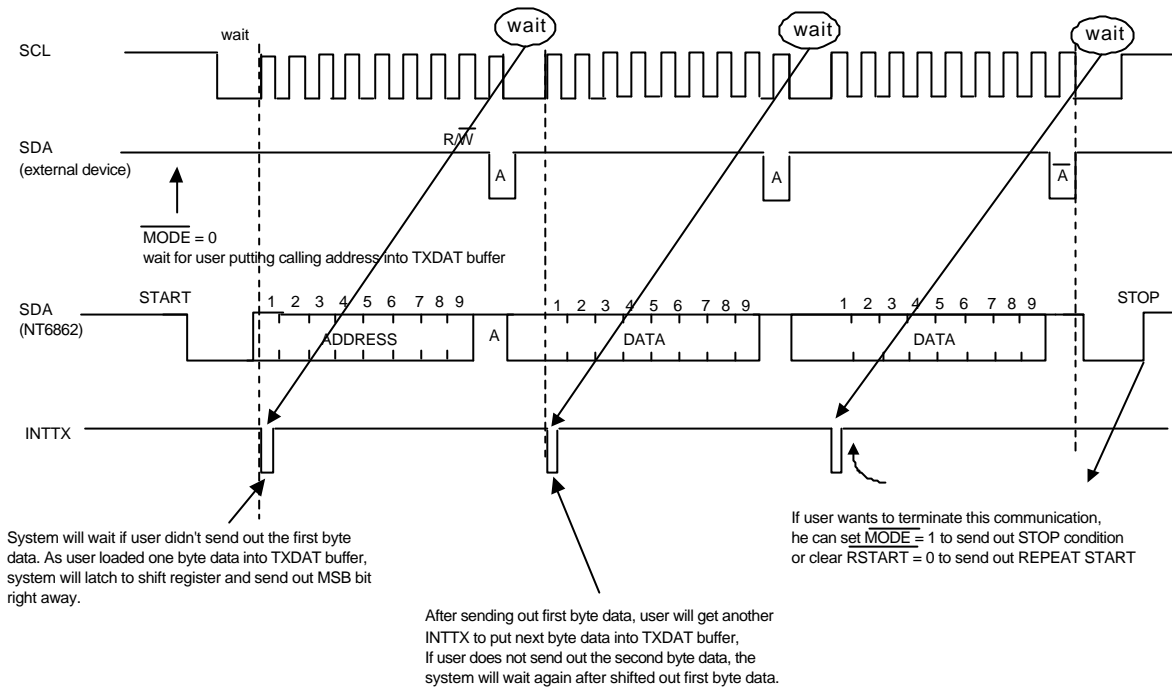

Figure 15.8. DDC2B+ MASTER WRITE Mode Timing

Control Register:

Addr	Register	INIT	Bit7	Bit6	Bit5	Bit4	Bit3	Bit2	Bit1	Bit0	R/W
Control Register for Polling Interrupt Groups											
\$0016	NMIPOLL	00H	-	-	-	-	-	-	INTE0	INTMUTE	R
			-	-	-	-	-	-	CLRE0	CLRMUTE	W
\$0017	IRQPOLL	00H	-	-	-	-	-	IRQ2	IRQ1	IRQ0	R
Control Registers of Interrupt Enable											
\$0018	IENMI	00H	-	-	-	-	-	-	INTE0	INTMUTE	W
\$0019	IEIRQ0	00H	-	-	INTS0	INTA0	INTTX0	INTRX0	INTNAK0	INTSTOP0	W
\$001A	IEIRQ1	00H	-	-	INTS1	INTA1	INTTX1	INTRX1	INTNAK1	INTSTOP1	W
\$001B	IEIRQ2	00H	-	-	-	-	-	INTV	INTE1	INTMR	W
Control Registers for Polling Interrupt Requests											
\$001C	IRQ0	00H	-	-	INTS0	INTA0	INTTX0	INTRX0	INTNAK0	INTSTOP0	R
			-	-	CLRS0	CLRA0	CLRTX0	CLRRX0	CLRNAK0	CLRSTOP0	W
\$001D	IRQ1	00H	-	-	INTS1	INTA1	INTTX1	INTRX1	INTNAK1	INTSTOP1	R
			-	-	CLRS1	CLRA1	CLRTX1	CLRRX1	CLRNAK1	CLRSTOP1	W
\$001E	IRQ2	00H	-	-	-	-	INTADC	INTV	INTE1	INTMR	R
			-	-	-	-	CLRADC	CLRV	CLRE1	CLMR	W
Control Register for DDC1/2B+ of Channel 0											
\$0021	CH0ADDR	A0H	ADR7	ADR6	ADR5	ADR4	ADR3	ADR2	ADR1	-	W
\$0022	CH0TXDAT	00H	TX7	TX6	TX5	TX4	TX3	TX2	TX1	TX0	W
\$0023	CH0RXDAT	00H	RX7	RX6	RX5	RX4	RX3	RX2	RX1	RX0	R
\$0024	CH0CON	E0H	$\overline{\text{ENDDC}}$	$\text{MD1}/\overline{2}$	-	START	STOP	-	$\overline{\text{TXACK}}$	-	W
			-	-	$\overline{\text{SRW}}$	START	STOP	-	-	-	R
\$0025	CH0CLK	FFH	$\overline{\text{MODE}}$	$\overline{\text{MRW}}$	$\overline{\text{RSTART}}$	-	-	DDC2BR2	DDC2BR1	DDC2BR0	W
Control Register for DDC1/2B+ of Channel 1											
\$0026	CH1ADDR	A0H	ADR7	ADR6	ADR5	ADR4	ADR3	ADR2	ADR1	-	W
\$0027	CH1TXDAT	00H	TX7	TX6	TX5	TX4	TX3	TX2	TX1	TX0	W
\$0028	CH1RXDAT	00H	RX7	RX6	RX5	RX4	RX3	RX2	RX1	RX0	R
\$0029	CH1CON	E0H	$\overline{\text{ENDDC}}$	$\text{MD1}/\overline{2}$	-	START	STOP	-	$\overline{\text{TXACK}}$	-	W
			-	-	$\overline{\text{SRW}}$	START	STOP	-	-	-	R
\$002A	CH1CLK	FFH	$\overline{\text{MODE}}$	$\overline{\text{MRW}}$	$\overline{\text{RSTART}}$	-	-	DDC2BR2	DDC2BR1	DDC2BR0	W

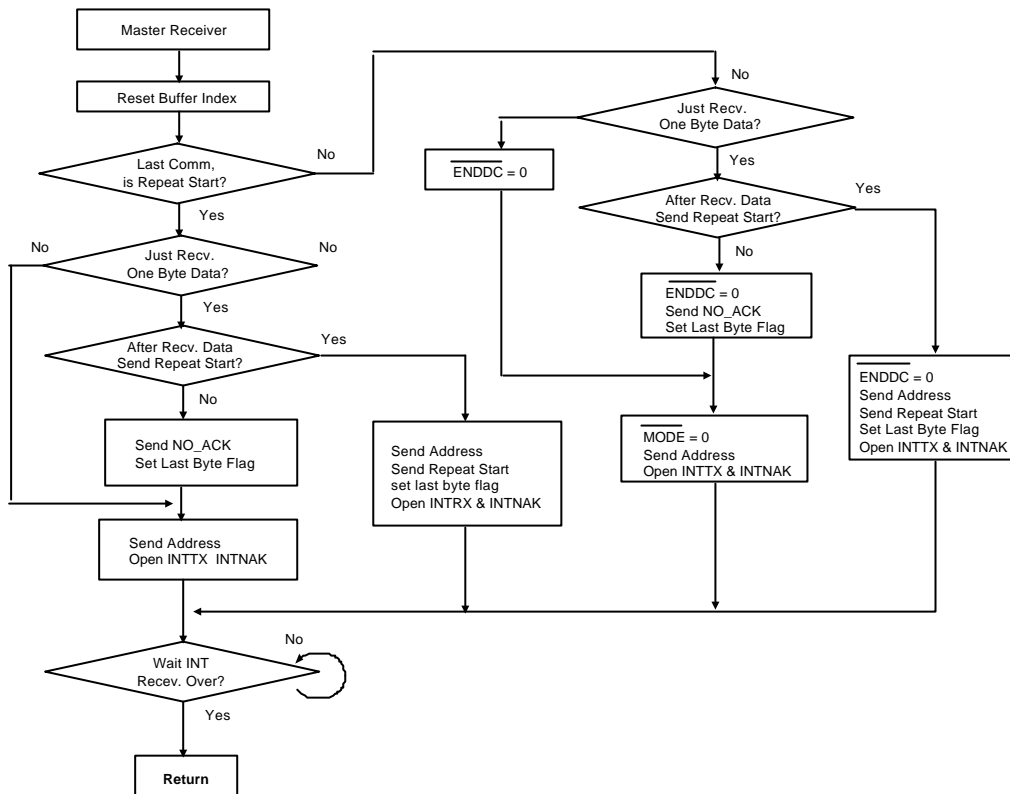

Figure 15.9. Master Receiver Operation

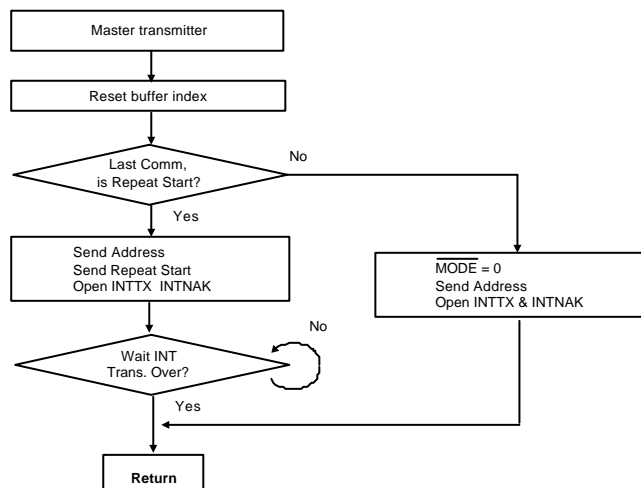

Figure 15.10. Master Transmitter Operation

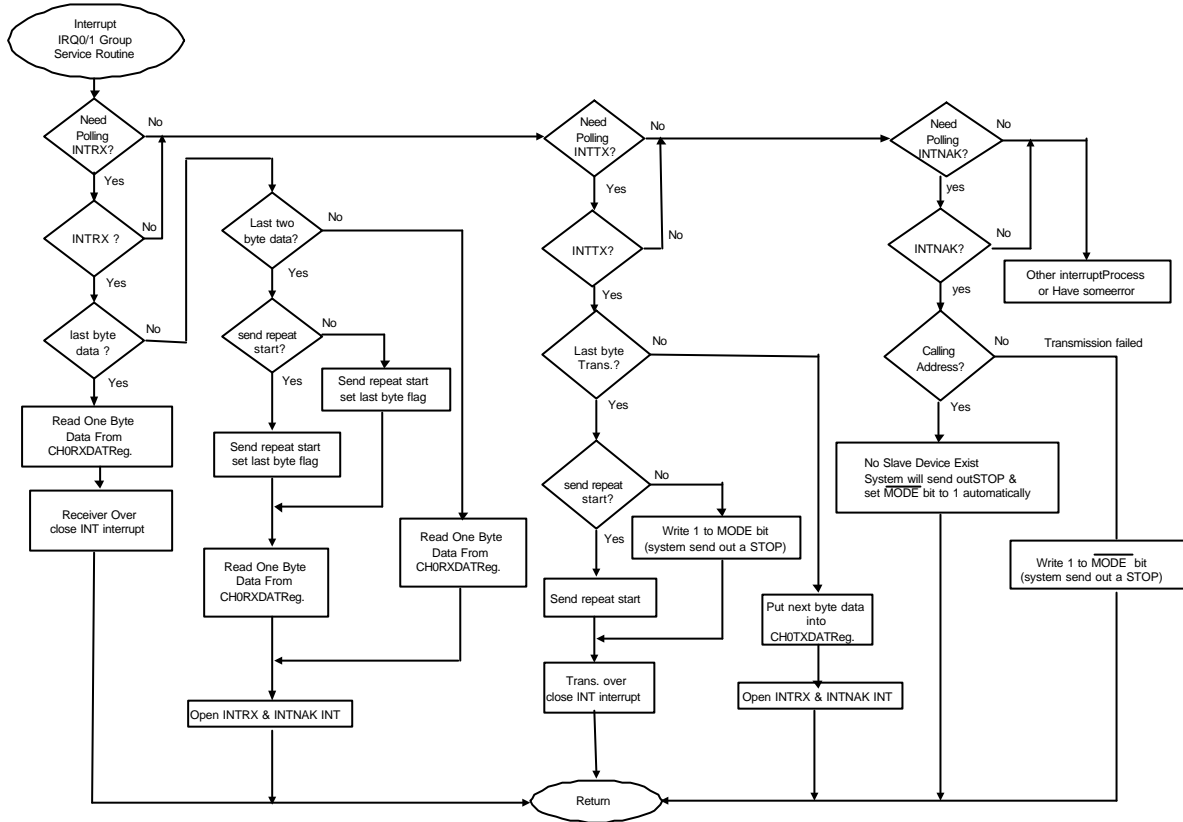

Figure 15.11. Master Mode INT Operation

User Referenced Flow Chart
Comparison With NT68P61A

Item	NT6861 Status	NT6862 Status	Notes
Maximum ROM Size	24K Bytes	32K Bytes	
RAM Size	256 Bytes	512 Bytes	
PWM Channel	14 channels 5V & 12V Open Drain O/P	13 channels 5V Open Drain O/P Only	
PWM Channel Refresh Rate	31.25 KHz	62.5 KHz	
A/D Converter Channel	2 channels	4 channels	6 bit resolution
V Counter Bit No.	12 Bits (handle Vsync freq. down to 30.5Hz)	14 Bits (handle Vsync freq. down to 7.6Hz)	
H Interval	8.192 ms	16.384 & 32.768 ms	
Auto Mute	X	O	
Free Run Freq.	2 sets	5 sets	
Self Test Pattern	X	O	2 self test patterns
IIC Bus Channel	1 channel	2 channels	
IIC Bus Baud Rate	Max 100KHz	Max 400KHz	
IIC Mode Supported	DDC1/2B	DDC1/2B+	
External Interrupt	1 set	2 sets	
NMI Interrupt	X	O	
Interrupt Trigger Edge Programmable	X	O	

DC Electrical Characteristics ($V_{DD} = 5V$, $T_A = 25^\circ C$, Oscillator freq. = 8MHz, Unless otherwise specified)

Symbol	Parameter	Min.	Typ.	Max.	Unit	Conditions
I_{DD}	Operating Current			20	mA	No Loading
V_{IH1}	Input High Voltage	2			V	P00-P07, P12-P16, P20-P27, P40, P41 \overline{RESET} , VSYNCl, HALFHI INTE0, INTE1
V_{IH2}	Input High Voltage	3			V	SCL0/1, SDA0/1, P10, P11, P30, P31 pins
V_{IH3}	Input High Voltage	2.2			V	HSYNCl
V_{IL1}	Input Low Voltage			0.8	V	P00-P07, P12-P16, P20-P27, P40, P41 \overline{RESET} , VSYNCl, HSYNCl, HALFHI, INTE0, INTE1
V_{IL2}	Input Low Voltage			1.5	V	SCL0/1, SDA0/1, P10, P11 P30 ,P31 pins
$V_{jitterH}$	Input Jitter Low Voltage	1.6		2.0	V	HSYNCl
$V_{jitterL}$	Input Jitter High Voltage	1.0		1.4	V	HSYNCl
I_{IH}	Input High Current		-200	-350	μA	P00-P07, P10-P16, P20-P27, P40,P41 VSYNCl, HSYNCl, HALFHI, \overline{RESET} ($V_{IH}=2.4V$);
V_{OH1}	Output High Voltage	2.4			V	P00-P07, P10-P16, P40, P41 ($I_{OH} = -100\mu A$) VSYNCO, HSYNCO ($I_{OH} = -4mA$) HALFHO ($I_{OH} = -4mA$) PATTERN, P20-P27 ($I_{OH} = -10mA$)
V_{OH2}	Output High Voltage (DAC0-DAC12)			5	V	external applied voltage
V_{OL}	Output Low Voltage			0.4	V	P00-P07, P10-P16, P40, P41, DAC0-12 ($I_{OL} = 4mA$) SCL0/1, SDA0/1 ($I_{OL} = 5mA$) VSYNCO, HSYNCO ($I_{OL} = 4mA$) HALFHO ($I_{OL} = 4mA$) PATTERN, P20-P27 ($I_{OL} = 10mA$)
R_{OL}	Pull Down Resistor (\overline{RESET})	50	100	150	$K\Omega$	
R_{OH1}	Pull up Resistor (INTE0, INTE1)	11	22	33	$K\Omega$	
R_{OH2}	Pull up Resistor (PORT0, PORT1, & PORT4)	11	22	33	$K\Omega$	
R_{OH3}	Pull up Resistor	11	22	33	$K\Omega$	

	(HSYNCI & VSYNCI & HALF1)					
--	---------------------------	--	--	--	--	--

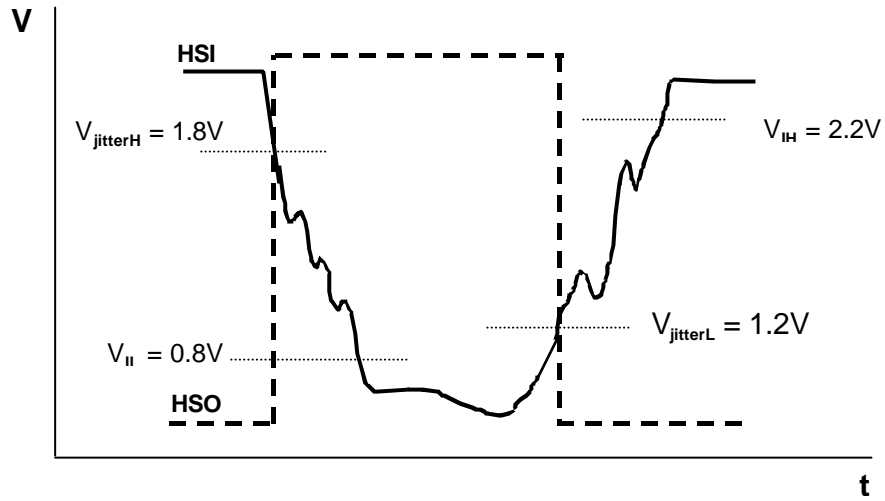

AC Electrical Characteristics ($V_{DD} = 5V$, $T_A = 25^\circ C$, Oscillator freq. = 8MHz, unless otherwise specified)

Symbol	Parameter	Min.	Typ.	Max.	Unit	Conditions
Fsys	System Clock		8		MHz	
tcNVT	A/D Conversion Time			750	μs	
Voffset	A/D Converter Error			1	LSB	
Vlinear	A/D Input Dynamic Range of Linearity Conversion	1.5		3.5	V	
tDELAY	The Delay Time of Vsync input and Vsync output			20	ns	Composite sync with fixed delay (Refer Figure 13.5)
tRESET	Reset Pulse Width Low	2			tcycle	tcycle = 2/ Fsys
Fvsync	Vsync Input Frequency			25K	Hz	tvsync = 1/Fvsync
tvpw	Vsync Input Pulse Width	8		2000	μs	
Fhsync	Hsync Input Frequency			120	KHz	tHsync = 1/Fhsync
tHPW1	Maximum Pulse Width of Hsync Input High (Positive Polarity)	0.25		7	μs	
tHPW2(sep)	Minimum Pulse Width of Hsync Input Low (Positive Polarity)	8			μs	Separate sync mode
tHPW2(comp)	Minimum Pulse Width of Hsync Input Low (Positive Polarity)	9.125			μs	Composite sync mode
tERROR1	Counting Deviation of Base Timer			1	μs	1 μs clock source
tERROR2	Counting Deviation of Base Timer			1	ms	1ms clock source

DDC1 Mode

Symbol	Parameter	Min.	Typ.	Max.	Unit	Conditions
t_{VPW}	Vsync High Time	0.50		2000	μs	
F_{Vsync}	Vsync Input Frequency	32		25K	Hz	$t_{Vsync} = 1/F_{Vsync}$
t_{DD}	Data Valid	200		500	ns	
t_{MODE}	Time for Transition to DDC2B Mode			500	ns	

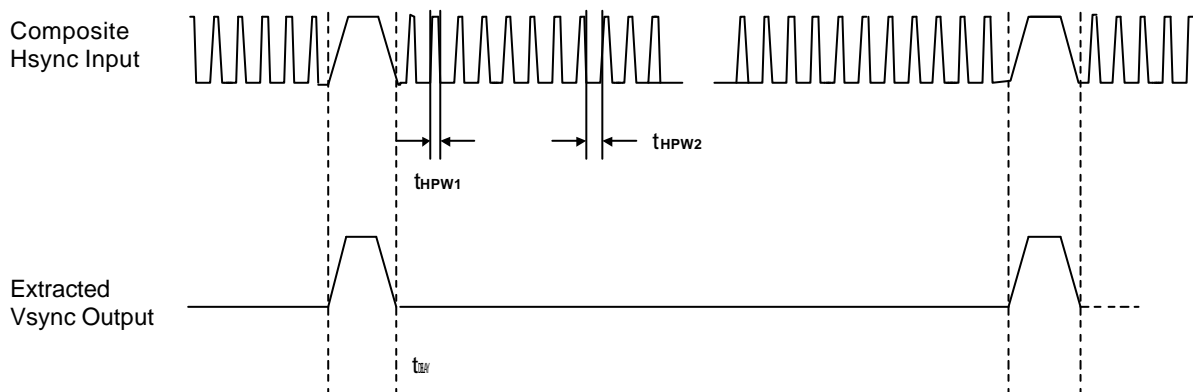
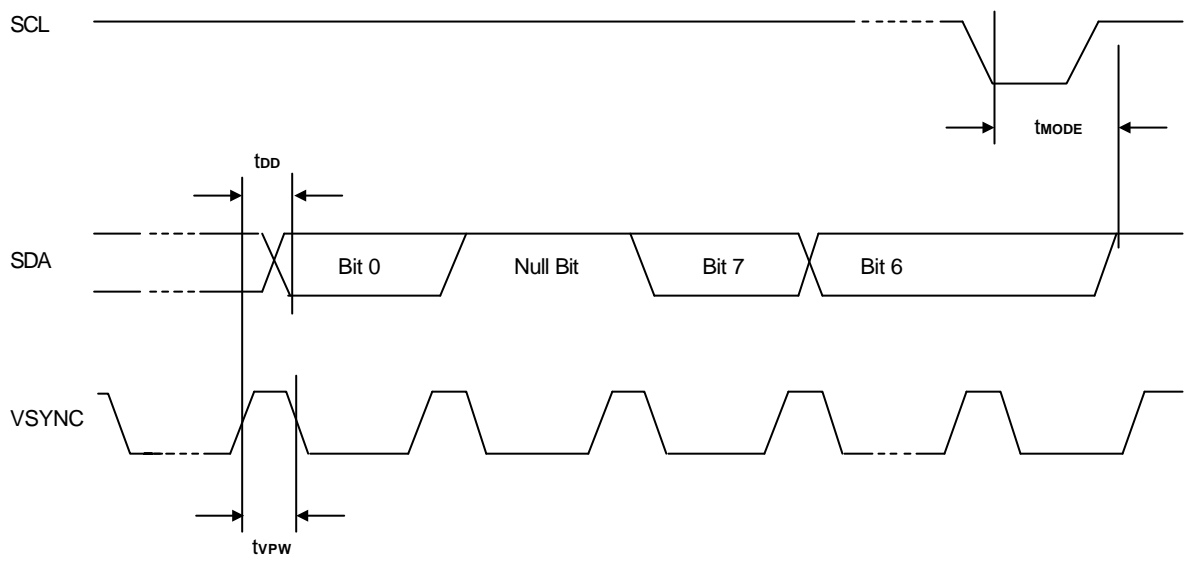

DDC2B+ Mode

Symbol	Parameter	Min.	Typ.	Max.	Unit
f _{SCL}	SCL Clock Frequency			400	KHz
t _{BUF}	Bus Free Between a STOP and START Condition	4.7			μs
t _{HD; STA}	Hold Time for START Condition	0.8			μs
t _{LOW}	LOW Period of The SCL Clock	1.3			μs
t _{HIGH}	HIGH Period of The SCL Clock	0.8			μs
t _{SU; STA}	Set-up Time for a Repeated START Condition	1.3			μs
t _{HD; DAT}	Data Hold Time	200			ns
t _{SU; DAT}	Data Set-up Time	300			ns
t _R	Rise Time of Both SDA and SCL Signals			1	μs
t _F	Fall Time of Both SDA and SCL Signals			300	ns
t _{SU; STO}	Set-up Time for STOP Condition	0.80			μs

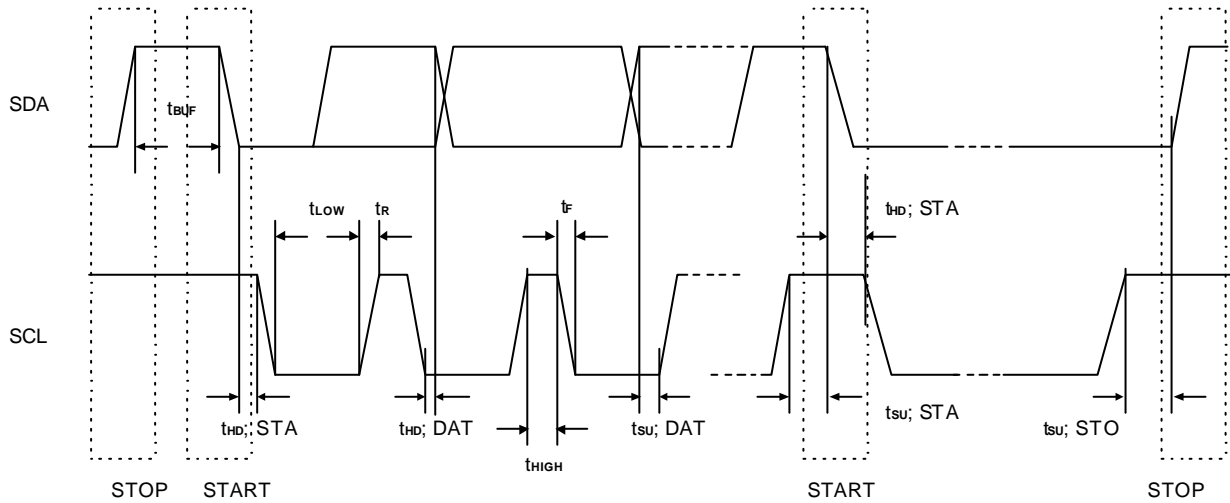

Ordering Information

Part No.	Packages
NT6862	40L P-DIP
NT6862U	42L S-DIP

Package Information
P-DIP 40L Outline Dimensions

unit: inches/mm

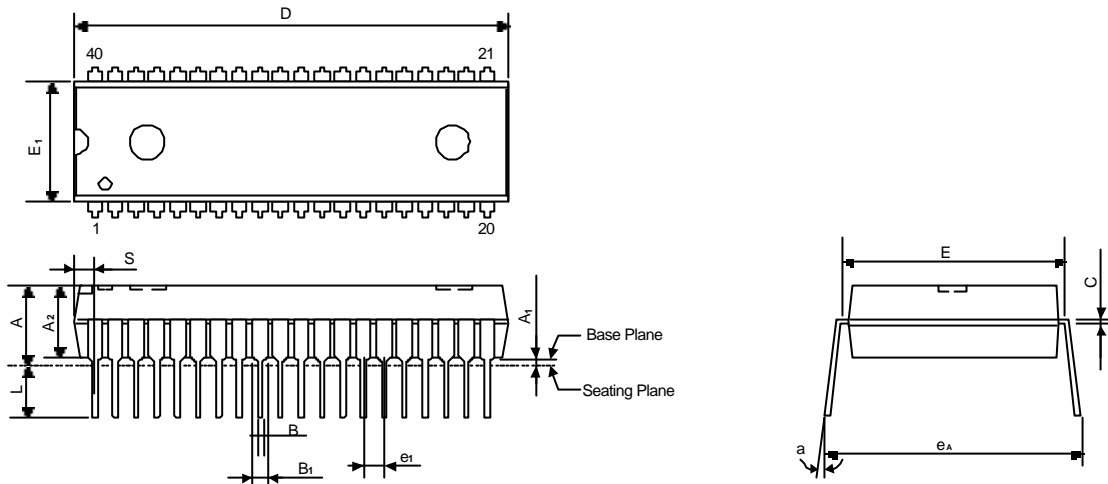

Symbol	Dimensions in inches	Dimensions in mm
A	0.210 Max.	5.33 Max.
A1	0.010 Min.	0.25 Min.
A2	0.155±0.010	3.94±0.25
B	0.018 +0.004 -0.002	0.46 +0.10 -0.05
B1	0.050 +0.004 -0.002	1.27 +0.10 -0.05
C	0.010 +0.004 -0.002	0.25 +0.10 -0.05
D	2.055 Typ. (2.075 Max.)	52.20 Typ. (52.71 Max.)
E	0.600±0.010	15.24±0.25
E1	0.550 Typ. (0.562 Max.)	13.97 Typ. (14.27 Max.)
e1	0.100±0.010	2.54±0.25
L	0.130±0.010	3.30±0.25
α	0° ~ 15°	0° ~ 15°
eA	0.655±0.035	16.64±0.89
S	0.093 Max.	2.36 Max.

Notes:

1. The maximum value of dimension D includes end flash.
2. Dimension E1 does not include resin fins.
3. Dimension S includes end flash.

Package Information
S-DIP 42L Outline Dimensions

unit: inches/mm

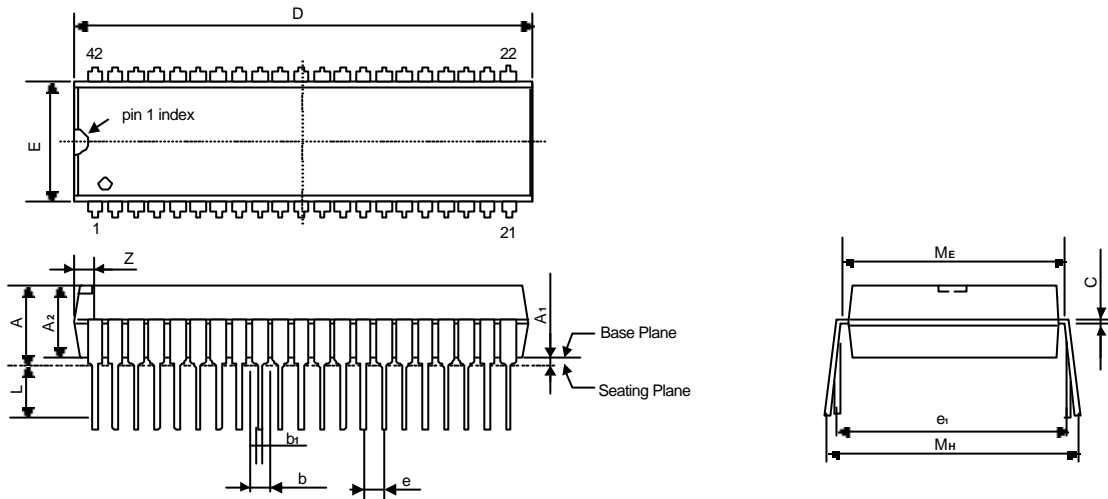

Symbol	Dimensions in inches	Dimensions in mm
A	0.200 Max.	5.08 Max.
A ₁	0.020 Min.	0.51 Min.
A ₂	0.157 Max.	4.0 Max.
b	0.051 Max. 0.031 Min.	1.3 Max. 0.8 Min.
b ₁	0.021 Max. 0.016 Min.	0.53 Max. 0.40 Min.
c	0.013 Max. 0.010 Min.	0.32 Max. 0.23 Min.
D ⁽¹⁾	1.531 Max. 1.512 Min.	38.9 Max. 38.4 Min.
E ⁽¹⁾	0.551 Max. 0.539 Min.	14.0 Max. 13.7 Min.
e	0.070	1.778
e ₁	0.600	15.24
L	0.126 Max. 0.114 Min.	3.2 Max. 2.9 Min.
M _E	0.622 Max. 0.600 Min.	15.80 Max. 15.24 Min.
M _H	0.675 Max. 0.626 Min.	17.15 Max. 15.90 Min.
w	0.007	0.18
Z ⁽¹⁾	0.068 Max.	1.73 Max.

Notes:

1. Plastic or metal protrusions of 0.25 mm maximum per side are not included.