

NX25Mxxx NX26Mxxx



NX25Mxxx AND NX26Mxxx SERIES REMOVABLE SERIAL FLASH MODULES

PRELIMINARY
FEBRUARY 1999

FEATURES

- **Serial Flash Module (SFM)**
 - Removable package for Serial Flash Memories
 - 128KB, 256KB, 512KB, 1MB, 2MB, and 4MB-byte capacities
 - Ideal for small portable/mobile products that store voice, images or data
 - Enables unlimited storage, revision updates and capacity upgrades
- **Smallest Removable Flash Card**
 - Relatively flat 15mm x 45mm (1.8" x 0.6") form factor. Less than 15% area of PCMCIA Card
- **Ultra-low Power and Fast Programming**
 - Single 5V or 3V supply for read, Erase/Write
 - As low as 5 mA @3V, less than 1 μ A standby
 - Up to 200KB/sec for Erase/Write
- **Simple Interface**
 - Supports NX25Fxxx SPI (4-pin) or NX26Fxxx NXS (2-pin) interfaces
 - Smart card style self-cleaning connector, only 8-contact pads
 - Device Information Sector allows identification of capacity, voltage and other characteristics
 - Optional electronic serial number
- **Reduces Overall System Costs**
 - Smaller case, simple PCB, low-cost connector
 - Fewer pins, simple microcontroller
 - Reduced power management, lower battery usage
- **Development Support**
 - PC-based Development Kit and Software

DESCRIPTION

The NX25Mxxx and NX26Mxxx Serial Flash Modules (SFM) provide the benefits of *NexFlash's* Serial Flash Memories in an innovative removable package. SFM support capacities of 128KB, 256KB, 512KB, 1MB, 2MB, and 4MB. SFM's are ideal for microcontroller-based applications, small portable and mobile products, and other resource-limited systems that store data, voice, and images. SFM's have a space-efficient form factor of 15mm (0.6") by 45mm (1.8") that is easy to handle and transport (see Figure 1). Simple electrical contacts, similar to those used in smart cards, provide for a reliable and cost-effective interface to a surface-mount slide-in connector (commonly used in GSM phones). Up to two Serial Flash Memories can be mounted onto the module which is made of standard FR4 Epoxy Glass PCB material.

There are two Serial Flash Module package types available: TSOP and Chip on Board (COB). The leads of the TSOP package are covered in molded epoxy. The COB version, which offers a thinner profile, has the chip mounted directly on the PCB covered in epoxy. Depending on the Serial Flash device used, modules can be read from and written to at supply voltages of 5V or 3V. Current consumption is as low

as 5 mA active and 1 μ A standby making them highly suitable for battery operation. The SFM's can accommodate *NexFlash's* NX25Fxxx SPI 4-pin interface or NX26Fxxx NXS 2-pin interface Serial Flash memory devices. DOS compatible sectors allow for sustained Erase/Write rates of over 200K bytes/sec. Other features of the Serial Flash Module include on-chip SRAM, electronic ID, flexible write protection and insertion/removal detection. (Note: This document is supplementary to the NX25Fxxx and NX26Fxxx Serial Flash Memory data sheets.)

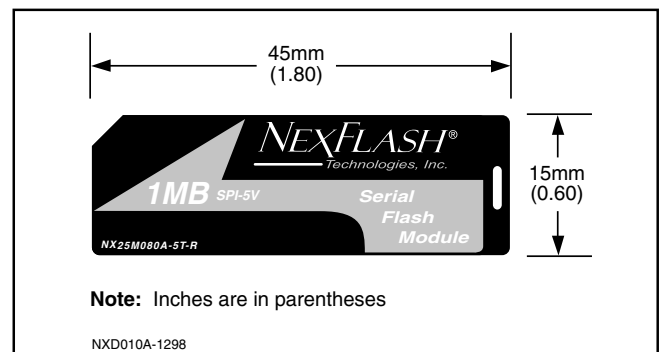

Figure 1. Serial Flash Module

This document contains PRELIMINARY INFORMATION. NexFlash reserves the right to make changes to its product at any time without notice in order to improve design and supply the best possible product. We assume no responsibility for any errors which may appear in this publication. © Copyright 1998, NexFlash Technologies, Inc.

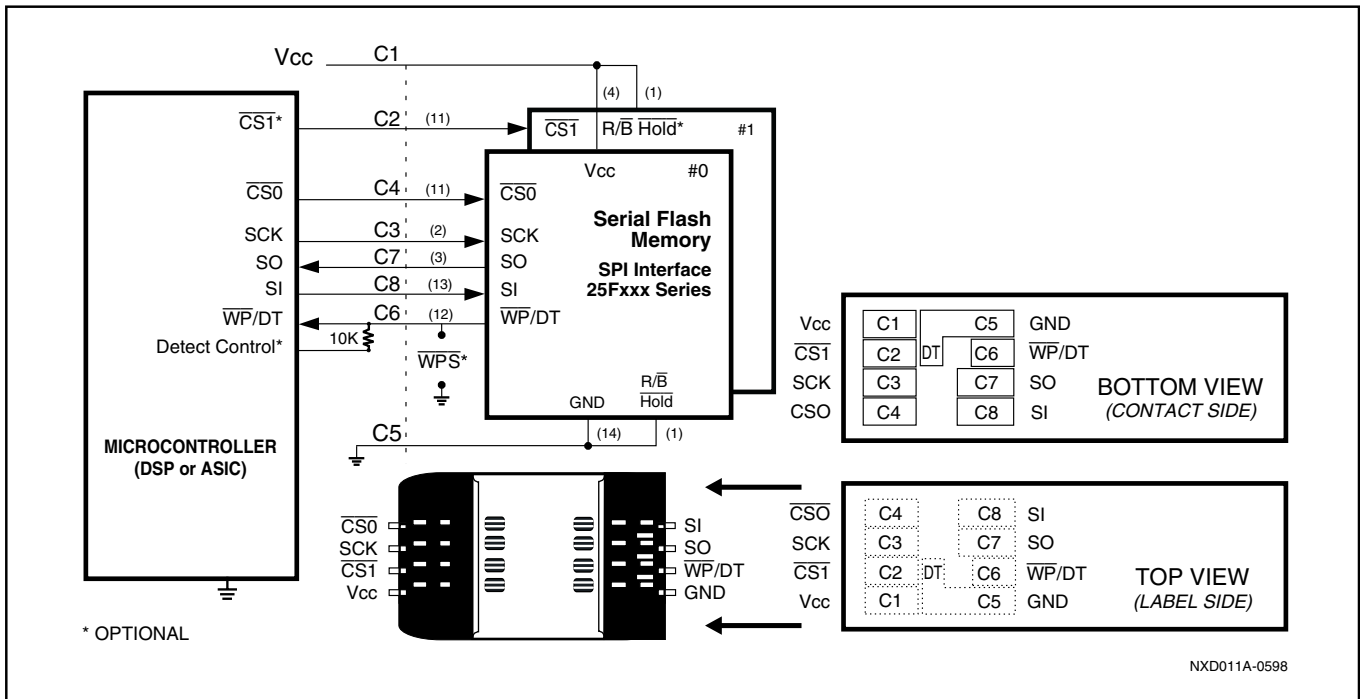

Figure 2. Typical interface for Serial Flash Module with SPI Interface using NX25Fxxx Series Devices.

Equivalent pin numbers for TSOP (Type II) are listed in parentheses. SPI contact assignments are shown for Bottom and Top Views of Serial Flash Module and Top View of the ITT Cannon Slide-insertion Connector (Model CCM-03-3504).

PIN DESCRIPTIONS

SPI NX25Fxxx Series

Note: See NX25Fxxx Data Sheets for further information

Power Supply Pins (Vcc and Gnd)

Supply source for 5V or 3V. Contact layout allows for the module to be inserted and removed while power is applied (“hot-socketing”) without damaging the module’s memory device.

Serial Data Input (SI)

The SPI bus Serial Data Input (SI) provides a means for commands or data to be written to (shifted into) the device.

Serial Data Output (SO)

The SPI bus Serial Data Output (SO) provides a means for data to be read from (shifted out of) the device. When the device is deselected ($\overline{CS}=1$) SO pin is in a high-impedance state.

Serial Clock (SCK)

All commands and data written to the Serial Input (SI) are clocked relative to the rising edge of Serial Clock (SCK). All data read from the Serial Data Output (SO) is clocked relative to the falling edge of SCK.

Chip Selects ($\overline{CS0}$ and $\overline{CS1}$)

$\overline{CS0}$ selects device location 0, which is on the contact side of the module. $\overline{CS1}$ selects device location 1, which is located on the opposite side of module from device #0. $\overline{CS1}$ is only used when a module has two serial flash memories. Chip select inputs are asserted low.

Write Protect/Detect ($\overline{WP/DT}$)

The Write Protect/Detect pin is an optional dual function pin.

Write Protect (\overline{WP})

Used as a Write Protect Input (\overline{WP}), when \overline{WP} is asserted (active low) the entire flash memory array is Write Protected. \overline{WP} can be controlled by the interface or as an optionally available contact pad directly on the module.

Detect (DT)

Using a pull-up resistor, a card detect (DT) can provide a low to high or high to low transition when the module is inserted or removed. The pulse is best used in conjunction with an interrupt input of a microcontroller or processor.

R/B Hold

The Ready/Busy-Hold pin function is not available for use with the SFM. This pin must be set to “No Connect” in the NX25Fxxx configuration register.

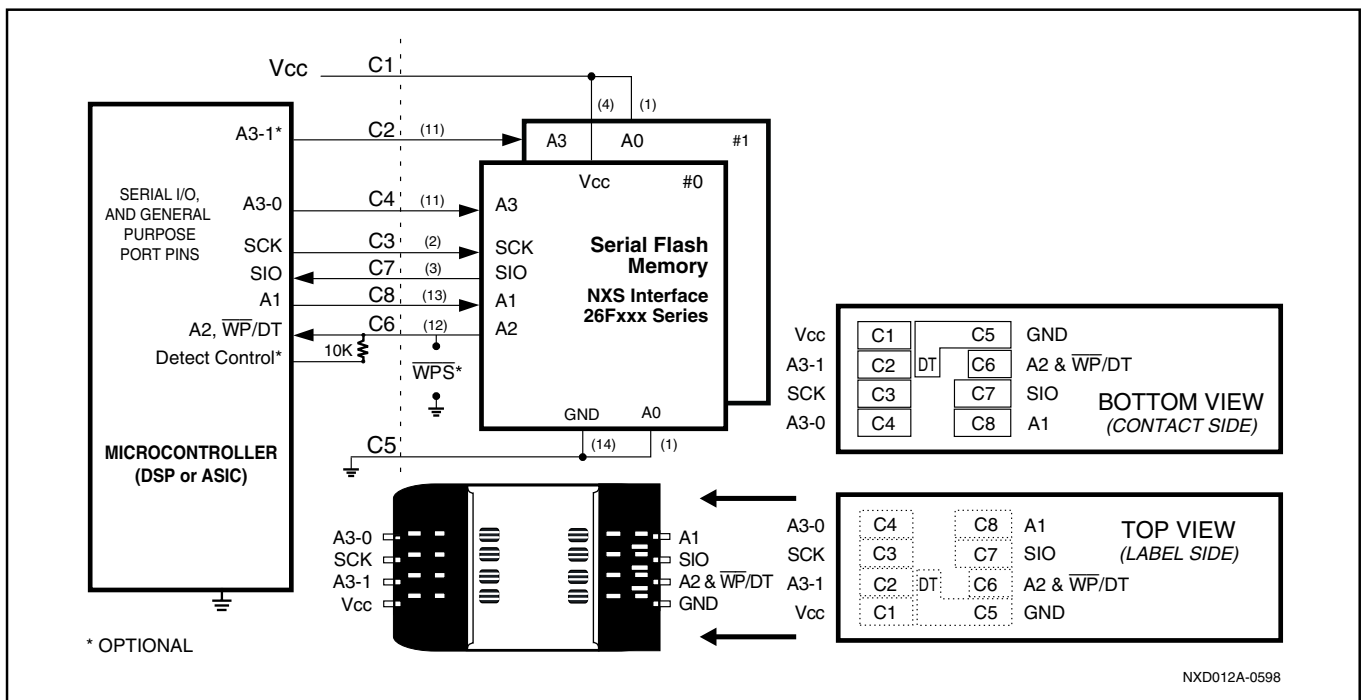

Figure 3. Typical interface for Serial Flash Module with NXS Interface using NX26Fxxx Series Devices.

Equivalent pin numbers for TSOP (Type II) are listed in parentheses. NXS contact assignments are shown for Bottom and Top Views of Serial Flash Module and Top View of the ITT Cannon Slide-insertion Connector (Model CCM-03-3504).

PIN DESCRIPTIONS

NXS NX26Fxxx Series

Note: See *NX26Fxxx Data Sheets* for further information

Power Supply Pins (Vcc and Gnd)

Supply source for 5 or 3.0V. Contact layout allows for the module to be inserted and removed while power is applied (“hot-socketing”) without damaging the module’s memory device.

Serial Data Input/Output (SIO)

The NXS bus Serial Data Input/Output (SIO) provides a means for commands or data to be written to (shifted into) the device or read from (shifted out of) the device. When the device is deselected SIO pin is in a high-impedance state.

Serial Clock (SCK)

All commands and data written to the Serial Input (SI) are clocked relative to the rising edge of Serial Clock (SCK). All data read from the Serial Data Output (SO) is clocked relative to the falling edge of SCK.

Device Address Pins (A0, A1, A2, A3)

There is no separate chip select signal for the NXS interface (NX26Fxxx series), instead four static address signals (A0, A1, A2, and A3) are provided for decoding one of 16 possible addresses. The A0 address signal, which is not

available on the contact pad, is tied low for device #0 (on the contact side) and is tied high for device #1 (optionally used on the top side). A1, A2, A3-0, and A3-1, which are available on the contact pad, must be tied high or low at the connector according to the desired address of device #0 or #1.

Write Protect/Detect (\overline{WP}/DT)

The Write Protect/Detect pin is an optional dual function pin.

Write Protect (\overline{WP})

Write Protect Input (\overline{WP}) can be used as a status indicator for the firmware to determine if a write protect condition exists on the SFM (if optional \overline{WP} switch or contact pad is available on the SFM). Unlike the NX25Fxxx SPI series the low on \overline{WP} does not provide a direct electrical protection of the device. Note that this pin also serves as the A2 address. If used for write protect status the change in device address must be taken into consideration.

Detect (DT)

Using a pull-up resistor, a card detect (DT) can provide a low-to-high or high-to-low transition when the module is inserted or removed. The pulse is best used in conjunction with an interrupt input of a microcontroller or processor. Note that this pin also serves as the A2 address. If used for detect status the device address must be taken into consideration.

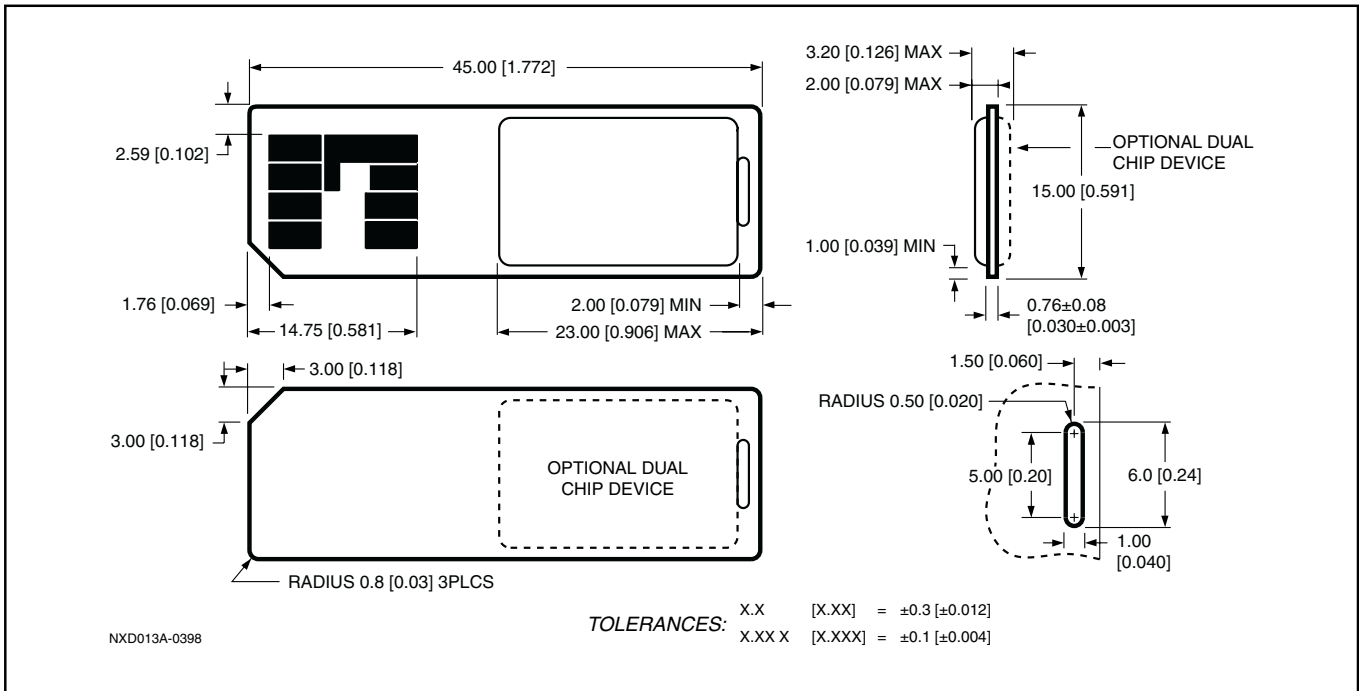

Figure 4. Serial Flash Module Package Dimensions TSOP with epoxy version
(Inches are in parentheses)

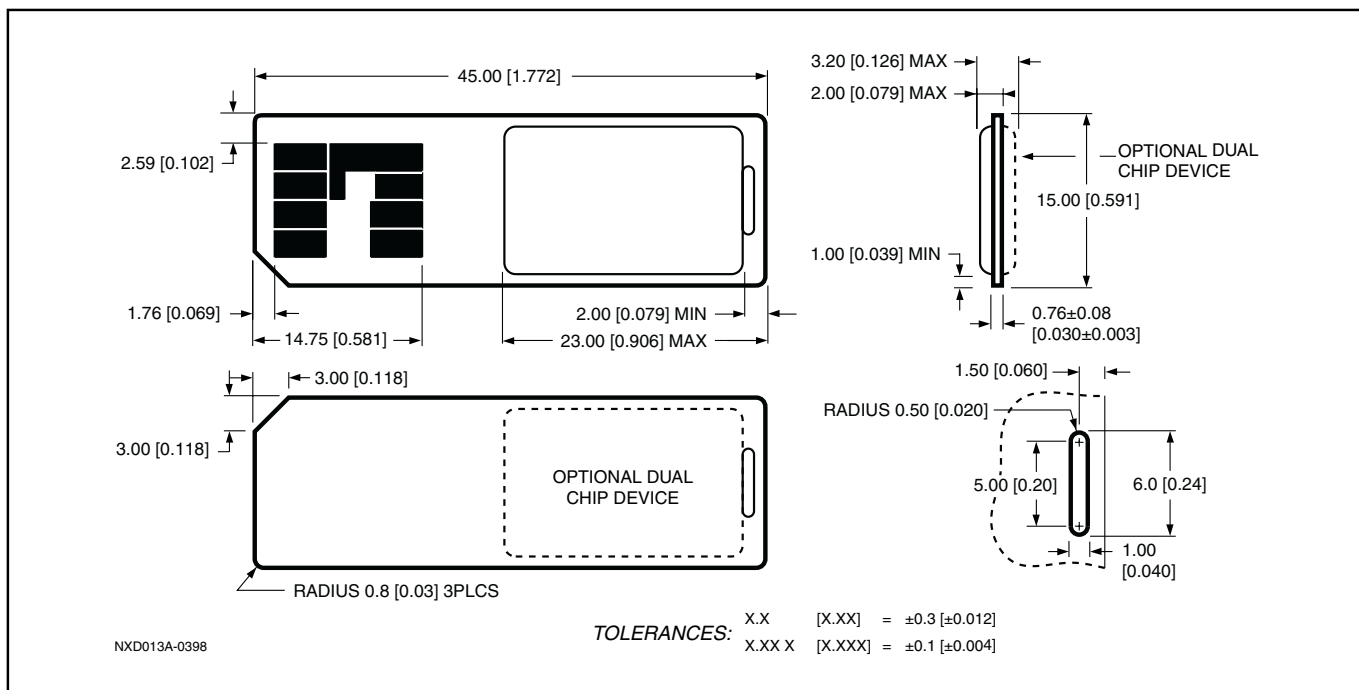

Figure 5. Serial Flash Module Package Dimensions COB with epoxy version
(Inches are in parentheses)

ABSOLUTE MAXIMUM RATINGS (1, 2)

Symbol	Parameter	Conditions	Range	Unit
V _{CC}	Supply Voltage		0 to 7.0	V
V _{IN} , V _{OUT}	Voltage Applied to Any Pin	Relative to Ground	-0.5 to V _{CC} + 0.5	V
EDC	Electro-static Discharge: Contact to Insulating or Conductive Plate.	JEIDA 4.1 Specification (Non A version devices)	±7,000	V
		JEIDA 4.1 Specification (A version devices)	±8,000	V
EDA	Electro-static Discharge: Air Discharge to Insulating or Conductive Plate.	IEC-1000-4-2 Specification (Non A version devices)	±7,000	V
		IEC-1000-4-2 Specification (A version devices)	±8,000	V
T _{ST}	Storage Temperature		-40 to +85	°C

Note:

1. This device has been designed and tested for the specified operation ranges. Proper operation outside of these levels is not guaranteed. Exposure beyond absolute maximum ratings (listed above) may cause permanent damage.
2. Proper care and handling of the Serial Flash Module is mandatory to ensure reliable operation. Avoid bending or subjecting the module to sudden impact. Avoid directly touching the connectors to protect from damage caused by static discharge. *NexFlash* cannot accept and hereby disclaims liability for any damage to the modules, including data corruption that may occur due to mishandling.

OPERATING RANGES

Symbol	Parameter	Conditions	Min	Typ	Max	Unit
V _{CC}	Supply Voltage for Reading and Writing Main Flash Array	See specific Serial Flash memory data sheet for 5V or 3V operating range.				
V _{CCDIS}	Supply Voltage for Reading Device Information Sector (DIS) to Identify Specified Voltage of Module.	DIS Read-only Voltage	2.7	—	5.5	V
T _A	Ambient Temperature, Operating	Commercial	0	—	+55	°C
		Extended ⁽²⁾	-15	—	+70	°C
		Industrial ⁽²⁾	-40	—	+85	°C
I _{RO}	Mechanical Insertion and Removal Cycles ⁽¹⁾	Office Environment Using ITT Cannon Connector CCM03-3504	5,000	10,000	—	Cycles

Note:

1. Tested on a sample basis or specified via design or characterization data.
2. Contact NexFlash for availability of extended and industrial grade devices.

AC AND DC ELECTRICAL CHARACTERISTICS

See associated NX25Fxxx or NX26Fxxx Serial Flash Memory Data Sheet

ORDERING INFORMATION

Size	Order Part No.	Package
128K-Byte	NX25M011A-3V-R	SPI, SFM, TSOP (V Type I) ≤32 RS, 3V
128K-Byte	NX25M011A-5V-R	SPI, SFM, TSOP (V Type I) ≤32 RS, 5V
128K-Byte	NX26M011A-3V-R	NXS, SFM, TSOP (V Type I) ≤32 RS, 3V
128K-Byte	NX26M011A-5V-R	NXS, SFM, TSOP (V Type I) ≤32 RS, 5V
512K-Byte	NX25M041A-3V-R	SPI, SFM, TSOP (V Type I) ≤32 RS, 3V
512K-Byte	NX25M041A-5V-R	SPI, SFM, TSOP (V Type I) ≤32 RS, 5V
512K-Byte	NX26M041A-3V-R	NXS, SFM, TSOP (V Type I) ≤32 RS, 3V
512K-Byte	NX26M041A-5V-R	NXS, SFM, TSOP (T Type I) ≤32 RS, 5V
1M-Byte	NX25M080A-3T-R	SPI, SFM, TSOP (T Type II) ≤64 RS, 3V
1M-Byte	NX25M080A-5T-R	SPI, SFM, TSOP (T Type II) ≤64 RS, 5V
1M-Byte	NX26M080A-3T-R	NXS, SFM, TSOP (T Type II) ≤64 RS, 3V
1M-Byte	NX26M080A-5T-R	NXS, SFM, TSOP (T Type II) ≤64 RS, 5V
2M-Byte	NX25M080A-3T2-R	SPI, SFM, Dual TSOP (T Type II) ≤64 RS, 3V
2M-Byte	NX25M080A-5T2-R	SPI, SFM, Dual TSOP (T Type II) ≤64 RS, 5V
2M-Byte	NX26M080A-3T2-R	NXS, SFM, Dual TSOP (T Type II) ≤64 RS, 3V
2M-Byte	NX26M080A-5T2-R	NXS, SFM, Dual TSOP (T Type II) ≤64 RS, 5V
2M-Byte	NX26M160-3T-R	NXS, SFM, TSOP (T Type II) ≤64 RS, 3.0-3.6V
2M-Byte	NX26M160-3C-R	NXS, SFM, COB (T Type II) ≤64 RS, 3.0-3.6V
2M-Byte	NX26M160-5T-R	NXS, SFM, TSOP (T Type II) ≤64 RS, 5V
2M-Byte	NX26M160-5C-R	NXS, SFM, COB (T Type II) ≤64 RS, 5V
4M-Byte	NX26M160-3T2-R	NXS, SFM, Dual TSOP (T Type II) ≤64 RS, 3.0-3.6V
4M-Byte	NX26M160-3C2-R	NXS, SFM, Dual COB (T Type II) ≤64 RS, 3.0-3.6V
4M-Byte	NX26M160-5T2-R	NXS, SFM, Dual TSOP (T Type II) ≤64 RS, 5V
4M-Byte	NX26M160-5C2-R	NXS, SFM, Dual COB (T Type II) ≤64 RS, 5V

Note: To order SFM's without labels contact *NexFlash's* Serial Flash Marketing Department.

PRELIMINARY DESIGNATION

The “Preliminary” designation on an *NexFlash* data sheet indicates that the product is not fully characterized. The specifications are subject to change and are not guaranteed. *NexFlash* or an authorized sales representative should be consulted for current information before using this product.

IMPORTANT NOTICE

NexFlash reserves the right to make changes to the products contained in this publication in order to improve design, performance or reliability. *NexFlash* assumes no responsibility for the use of any circuits described herein, conveys no license under any patent or other right, and makes no representation that the circuits are free of patent infringement. Charts and schedules contained herein reflect representative operating parameters, and may vary depending upon a user’s specific application. While the information in this publication has been carefully checked, *NexFlash* shall not be liable for any damages arising as a result of any error or omission.

LIFE SUPPORT POLICY

NexFlash does not recommend the use of any of its products in life support applications where the failure or malfunction of the product can reasonably be expected to cause failure in the life support system or to significantly affect its safety or effectiveness. Products are not authorized for use in such applications unless *NexFlash* receives written assurances, to its satisfaction, that:

- (a) the risk of injury or damage has been minimized;
- (b) the user assumes all such risks; and
- (c) potential liability of *NexFlash* is adequately protected under the circumstances.

Trademarks:

NexFlash is a trademark of *NexFlash Technologies, Inc.* All other marks are the property of their respective owner.



2711 North First Street • San Jose, CA 95134
Ph: 408-907-3600 • Fx: 408-907-3601 • sales@nexflash.com
www.nexflash.com