

ML64168

4-Bit Microcontroller with Built-in RC Oscillation Type A/D Converter and LCD Driver

GENERAL DESCRIPTION

The ML64168 is a low power 4-bit microcontroller incorporating the Oki's original CPU core nX-4/30. The ML64168 provides a minimum instruction execution time of 4.3 μ s (@700kHz).

The ML64168 contains 8160-byte program memory, 512-nibble data memory, three 4-bit input-output ports, 4-bit input port, 4-bit output port, 2-channel RC oscillation type A/D converter, LCD driver for up to 120 segments, and buzzer output port.

The ML64P168 is the one-time-programmable ROM version of ML64168, having one-time PROM(OTP) as internal program memory. The ML64P168 is used to evaluate the software development.

APPLICATION

The ML64168 is best suited for low power, high precision thermometers and hygrometers.

FEATURES

- Processing speed
 - Minimum instruction execution time : 4.3 μ s @700 kHz
91.6 μ s @32.768 kHz
- Clock generation circuit
 - Low-speed clock : 32.768 kHz crystal oscillator
 - High-speed clock : 700 kHz RC oscillator (with an external resistor)
 - CPU clock is selectable as Low-speed clock / High-speed clock by software.
- Operating voltage : 1.5 V spec. / 3.0 V spec. (selectable by mask option)
 - 1.25 to 1.70 V (1.5 V spec.)
 - 2.0 to 3.50 V (3.0 V spec.)
 - 2.2 to 3.50 V (3.0 V spec., 1/2duty)
- Operating temperature : - 40 to +85°C
- Memory space
 - Internal program memory : 8160 bytes
 - Internal data memory : 512 nibbles
- RC oscillation type A/D converter : 2 channels
 - Time division 2-channel method
 - Counter A : $1 / (10^4 \times 8) \times 1$
 - Counter B : $1 / 2^{14} \times 1$

The information contained herein can change without notice owing to product and/or technical improvements. Before using the product, please make sure that the information being referred to is up-to-date.

- I/O port
 - Input-output port : 3 ports × 4 bits
 - Input port : 1 port × 4 bits
 - Output port : 1 port × 4 bits
(8 out of the 34 LCD driver outputs can be used as output-only ports by mask option.)
- LCD driver : 34 outputs
 - (1) At 1/4 duty and 1/3 bias : 120 segments (max.)
 - (2) At 1/3 duty and 1/3 bias : 93 segments (max.)
 - (3) At 1/2 duty and 1/2 bias : 64 segments (max.)
- Voltage Regulator for LCD Driver (selectable by mask option)

The LCD panel display is stable regardless of temporary supply voltage drop, because the voltage generated by the voltage regulator for LCD driver is supplied to the bias voltage generator as a reference voltage.
- LCD Operating Voltage
 - When the voltage regulator for LCD driver is used
 - : 3.6 V (Duty cycle = 1/4 or 1/3)
 - : 2.4 V (Duty cycle = 1/2)
 - When the voltage regulator for LCD driver is not used
 - : 4.5 V (Duty cycle = 1/4 or 1/3)
 - : 3.0 V (Duty cycle = 1/2)
- Buzzer driver : 1 output (4 output modes selectable)
- Serial port : Synchronous 8-bit transfer
Selectable as external clock / internal clock
Selectable as MSB first / LSB first
- Capture circuit : 2 channels (32Hz, 64Hz, 128Hz, 256Hz)
- Battery check circuit : 1 (incorporated into the input-only port)
- Watchdog timer
- Interrupt
 - External interrupt : 2 sources
 - Internal interrupt : 8 sources
- Package:
 - 80-pin plastic QFP (QFP80-P-1420-0.80-BK) : (Product name : ML64168-xxxGP)
 - 80-pin plastic QFP (QFP80-P-1414-0.65-K) : (Product name : ML64168-xxxGA)
 - 80-pin plastic TQFP (TQFP80-P-1212-0.50-K):(Product name : ML64168-xxxTB)
 - Chip : (Product name : ML64168-xxx)
xxx indicates a code number.

PROGRAM DEVELOPMENT ENVIRONMENT

- Structured Assembler : SASM64K
- In Circuit Emulator : EASE64168
- Debugger : DT64K
- OTP version product : ML64P168
(replaces the built-in program memory with one-time PROM)

BLOCK DIAGRAM

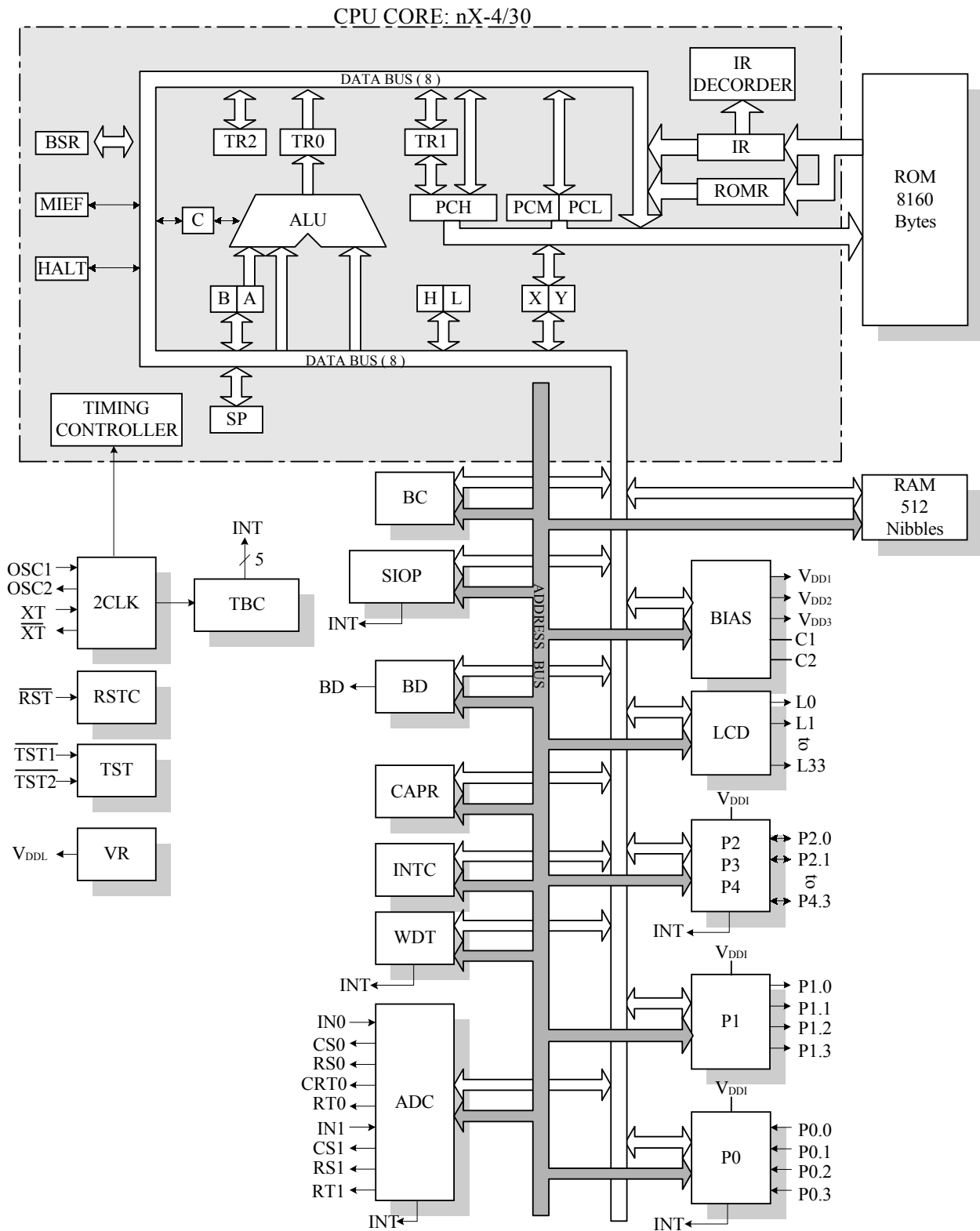

PIN CONFIGURATION (TOP VIEW)

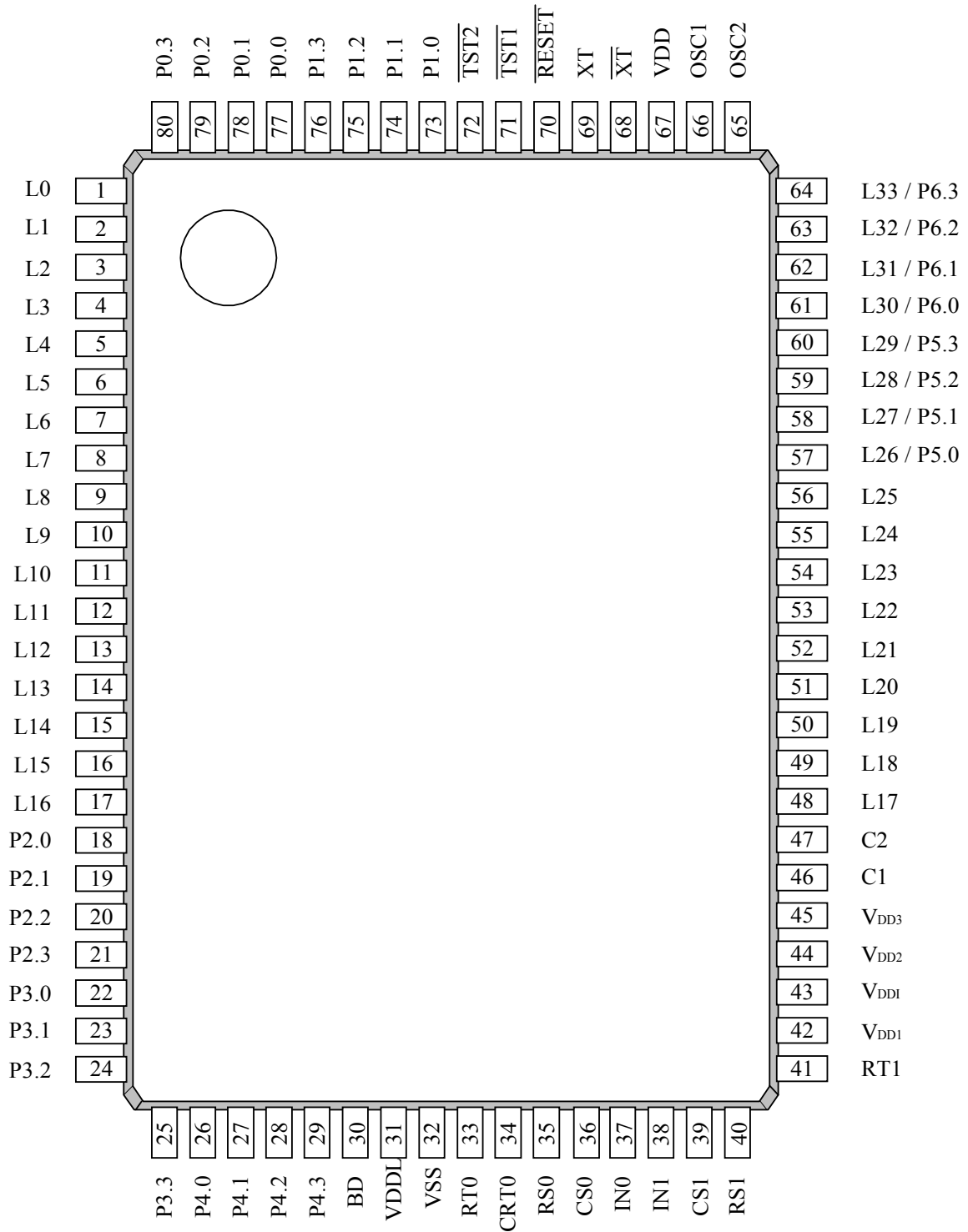

(GP : QFP80-P-1420-0.80-BK)

80-Pin Plastic QFP

PAD CONFIGURATION

Pad Layout

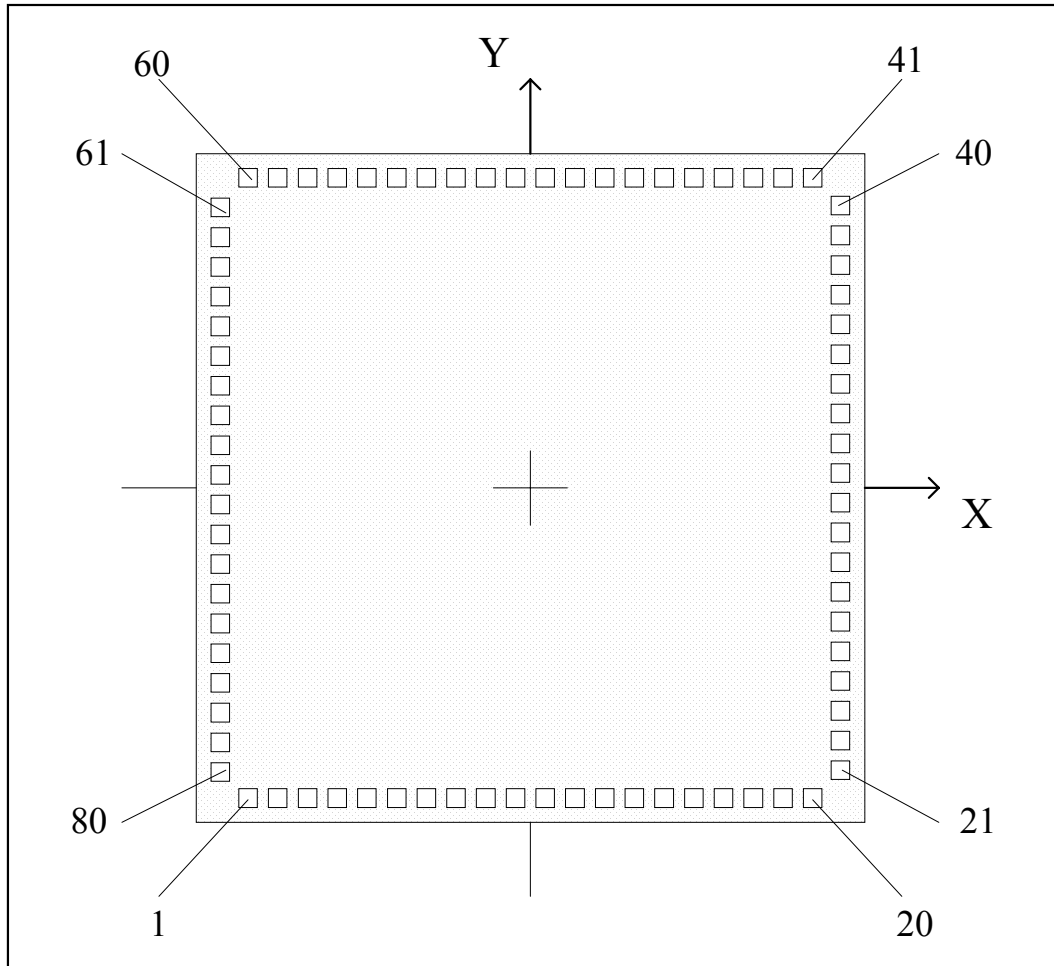

Pad Coordinates

Pad No	CARD NAME	X (um)	Y (um)	Pad No	CARD NAME	X (um)	Y (um)
1	L2	-2115.0	-2555.0	41	VDDI	2110.0	2555.0
2	L3	-1843.5	-2555.0	42	VDD2	1845.0	2555.0
3	L4	-1575.0	-2555.0	43	VDD3	1575.0	2555.0
4	L5	-1365.0	-2555.0	44	C1	1365.0	2555.0
5	L6	-1155.0	-2555.0	45	C2	1155.0	2555.0
6	L7	-945.0	-2555.0	46	L17	945.0	2555.0
7	L8	-735.0	-2555.0	47	L18	765.0	2555.0
8	L9	-525.0	-2555.0	48	L19	585.0	2555.0
9	L10	-315.0	-2555.0	49	L20	405.0	2555.0
10	L11	-105.0	-2555.0	50	L21	225.0	2555.0
11	L12	105.0	-2555.0	51	L22	45.0	2555.0
12	L13	315.0	-2555.0	52	L23	-135.0	2555.0
13	L14	525.0	-2555.0	53	L24	-315.0	2550.0
14	L15	735.0	-2555.0	54	L25	-667.0	2508.0
15	L16	945.0	-2555.0	55	L26	-987.0	2508.0
16	P2.0	1155.0	-2555.0	56	L27	-1307.0	2508.0
17	P2.1	1365.0	-2555.0	57	L28	-1487.0	2508.0
18	P2.2	1575.0	-2555.0	58	L29	-1697.0	2508.0
19	P2.3	1819.5	-2555.0	59	L30	-1907.0	2508.0
20	P3.0	2110.0	-2555.0	60	L31	-2117.0	2508.0
21	P3.1	2390.0	-2285.0	61	L32	-2390.0	2285.0
22	P3.2	2390.0	-2005.0	62	L33	-2390.0	2005.0
23	P3.3	2390.0	-1725.0	63	OSC2	-2390.0	1725.0
24	P4.0	2390.0	-1495.0	64	OSC1	-2390.0	1495.0
25	P4.1	2390.0	-1265.0	65	VDD	-2390.0	1265.0
26	P4.2	2390.0	-1035.0	66	\overline{XT}	-2390.0	1035.0
27	P4.3	2390.0	-805.0	67	XT	-2390.0	805.0
28	BD	2390.0	-575.0	68	\overline{RESET}	-2390.0	575.0
29	VDDL	2390.0	-345.0	69	$\overline{TST1}$	-2390.0	345.0
30	VSS	2390.0	-115.0	70	$\overline{TST2}$	-2390.0	115.0
31	RT0	2390.0	115.0	71	P1.0	-2390.0	-115.0
32	CRT0	2390.0	345.0	72	P1.1	-2390.0	-345.0
33	RS0	2390.0	575.0	73	P1.2	-2390.0	-575.0
34	CS0	2390.0	805.0	74	P1.3	-2390.0	-805.0
35	IN0	2390.0	1035.0	75	P0.0	-2390.0	-1035.0
36	IN1	2390.0	1265.0	76	P0.1	-2390.0	-1265.0
37	CS1	2390.0	1495.0	77	P0.2	-2390.0	-1495.0
38	RS1	2390.0	1725.0	78	P0.3	-2390.0	-1725.0
39	RT1	2390.0	2005.0	79	L0	-2390.0	-2005.0
40	VDD1	2390.0	2285.0	80	L1	-2390.0	-2285.0

PIN DESCRIPTIONS

The basic functions of each pin of the ML64168 is described in Table 1.

A symbol with a slash (/) denotes a pin that has a secondary function.

Refer to Table 2 for secondary functions.

For Type, “ - ” denotes a power supply pin, “ I ” an input pin, “ O ” an output pin, and “ I/O ” an input-output pin.

Table 1 Pin Descriptions (Basic Functions)

Function	Symbol	Pin No.		Pad No.	Type	Description
		GP	GA, TB			
Power Supply	V _{SS}	32	30	30	-	0V power supply
	V _{DD}	67	65	65	-	Positive power supply
	V _{DD1}	42	40	40	-	Bias output for driving LCD (+1.5V, +1.2V*)
	V _{DD2}	44	42	42	-	Bias output for driving LCD (+3.0V, +2.4V*)
	V _{DD3}	45	43	43	-	Bias output for driving LCD (+4.5V, +3.6V*)
	V _{DDI}	43	41	41	-	Positive power supply for I/O port interface
	V _{DDL}	31	29	29	-	Positive power supply for internal logic (An internally generated constant voltage is present at this pin.)
	C1	46	44	44	-	Pins for connecting a capacitor for generating LCD driving bias
	C2	47	45	45	-	
Oscillation	$\overline{\text{XT}}$	69	67	67	I	Low-speed clock oscillation input and output pins. Connect to a crystal (32.768kHz).
	XT	68	66	66	O	
	OSC1	66	64	64	I	High-speed clock oscillation input and output pins. Connect to an external resistor for oscillation (Ros).
	OSC2	65	63	63	O	
Test	$\overline{\text{TST1}}$	71	69	69	I	Input pins for testing. A pull-up resistor is internally connected to these pins.
	$\overline{\text{TST2}}$	72	70	70	I	
Reset	$\overline{\text{RESET}}$	70	68	68	I	System reset input pin. Setting this pin to “ L ” level puts this device into a reset state. Then, setting this pin to “ H ” level starts executing an instruction from address 0000H.

* When the voltage regulator for LCD driver is used.

Table 1 Pin Descriptions (Basic Functions) (continued)

Function	Symbol	Pin No.		Pad No.	Type	Description
		GP	GA, TB			
Ports	P0.0/ INT1/ CAPIN0	77	75	75	I	4-bit input port (Port 0) Selectable as pull-up resistor input, pull-down resistor input, or high impedance input by the port 01 control register (P01CON).
	P0.1/ INT1/ CAPIN1	78	76	76		
	P0.2/ INT1	79	77	77		
	P0.3/ INT1/ CMP	80	78	78		
	P1.0	73	71	71	O	4-bit output port (Port 1) Selectable as NMOS open drain output or CMOS output by the port 01 control register (P01CON). P1.0 is a high current drive output port.
	P1.1	74	72	72		
	P1.2	75	73	73		
	P1.3	76	74	74		
	P2.0/ INT0	18	16	16	I/O	4-bit input-output port (Port 2) Following can be specified for each bit by the port 2 control registers 0 to 3 (P20CON to P23CON). (1) input or output (2) pull-up/pull-down resistor input or high impedance input (3) NMOS open drain output or CMOS output
	P2.1/ INT0	19	17	17		
	P2.2/ INT0	20	18	18		
	P2.3/ INT0	21	19	19		
	P3.0/ INT0	22	20	20	I/O	4-bit input-output port (Port 3) Following can be specified for each bit by the port 3 control registers 0 to 3 (P30CON to P33CON). (1) input or output (2) pull-up/pull-down resistor input or high impedance input (3) NMOS open drain output or CMOS output
	P3.1/ INT0	23	21	21		
	P3.2/ INT0	24	22	22		
	P3.3/ INT0/ SIN	25	23	23		
P4.0/ INT0/ SOUT	26	24	24	I/O	4-bit input-output port (Port 4) Following can be specified for each bit by the port 4 control registers 0 to 3 (P40CON to P43CON). (1) input or output (2) pull-up/pull-down resistor input or high impedance input (3) NMOS open drain output or CMOS output	
P4.1/ INT0/ SPR	27	25	25			
P4.2/ INT0/ SCLK	28	26	26			
P4.3/ INT0/ MON	29	27	27			

Table 1 Pin Descriptions (Basic Functions) (continued)

Function	Symbol	Pin No.		Pad No.	Type	Description
		GP	GA, TB			
Buzzer	BD	30	28	28	O	Output pin for the buzzer driver.
A/D Converter	RT0	33	31	31	O	Resistance temperature sensor connection pin (for channel 0)
	CRT0	34	32	32	O	Resistance/capacitance temperature sensor connection pin (for channel 0)
	RS0	35	33	33	O	Reference resistor connection pin (for channel 0)
	CS0	36	34	34	O	Reference capacitor connection pin (for channel 0)
	IN0	37	35	35	I	Input pin for RC oscillator circuit (for channel 0)
	RT1	41	39	39	O	Resistance temperature sensor connection pin (for channel 1)
	RS1	40	38	38	O	Reference resistor connection pin (for channel 1)
	CS1	39	37	37	O	Reference capacitor connection pin (for channel 1)
	IN1	38	36	36	I	Input pin for RC oscillator circuit (for channel 1)

Table 1 Pin Descriptions (Basic Functions) (continued)

Function	Symbol	Pin No.		Pad No.	Type	Description
		GP	GA, TB			
LCD Driver	L0	1	79	79	O	LCD segment and common signals output pins.
	L1	2	80	80	O	
	L2	3	1	1	O	
	L3	4	2	2	O	
	L4	5	3	3	O	
	L5	6	4	4	O	
	L6	7	5	5	O	
	L7	8	6	6	O	
	L8	9	7	7	O	
	L9	10	8	8	O	
	L10	11	9	9	O	
	L11	12	10	10	O	
	L12	13	11	11	O	
	L13	14	12	12	O	
	L14	15	13	13	O	
	L15	16	14	14	O	
	L16	17	15	15	O	
	L17	48	46	46	O	
	L18	49	47	47	O	
	L19	50	48	48	O	
	L20	51	49	49	O	
	L21	52	50	50	O	
	L22	53	51	51	O	
	L23	54	52	52	O	
	L24	55	53	53	O	
	L25	56	54	54	O	
	L26 / P5.0	57	55	55	O	LCD segment and common signals output pins. These pins can be configured to be output ports by a mask option.
	L27 / P5.1	58	56	56	O	
	L28 / P5.2	59	57	57	O	
	L29 / P5.3	60	58	58	O	
	L30 / P6.0	61	59	59	O	
	L31 / P6.1	62	60	60	O	
	L32 / P6.2	63	61	61	O	
L33 / P6.3	64	62	62	O		

Table 2 Pin Descriptions (Secondary Functions)

Function	Symbol	Pin No.		Pad No.	Type	Description
		GP	GA, TB			
External Interrupt	P2.0/ INT0	18	16	16	I	Secondary functions of P2.0 to P2.3, P3.0 to P3.3, and P4.0 to P4.3: Level-triggered external 0 interrupt input pins. The change of input signal level causes an interrupt to occur.
	P2.1/ INT0	19	17	17		
	P2.2/ INT0	20	18	18		
	P2.3/ INT0	21	19	19		
	P3.0/ INT0	22	20	20	I	
	P3.1/ INT0	23	21	21		
	P3.2/ INT0	24	22	22		
	P3.3/ INT0	25	23	23	I	
	P4.0/ INT0	26	24	24		
	P4.1/ INT0	27	25	25		
	P4.2/ INT0	28	26	26		
	P4.3/ INT0	29	27	27	I	
P0.0/ INT1	77	75	75			
P0.1/ INT1	78	76	76			
P0.2/ INT1	79	77	77			
P0.3/ INT1	80	78	78	I		
P0.0/ CAPIN0	77	75	75			
Capture trigger	P0.1/ CAPIN1	78	76	76	I	Secondary functions of P0.0: This pin is assigned the capture circuit trigger input pin of CAPR0 function .
						Secondary functions of P0.1: This pin is assigned the capture circuit trigger input pin of CAPR1 function .
Serial port	P3.3/ SIN	25	23	23	I	Secondary functions of P3.3: This pin is assigned the data input of a serial port.
	P4.0/ SOUT	26	24	24	O	Secondary functions of P4.0: This pin is assigned the data output of a serial port.
	P4.1/ SPR	27	25	25	O	Secondary functions of P4.1: This pin is assigned the ready output of a serial port.
	P4.2/ SCLK	28	26	26	I/O	Secondary functions of P4.2: This pin is assigned the clock input-output of a serial port.

Table 2 Pin Descriptions (Secondary Functions) (continued)

Function	Symbol	Pin No.		Pad No.	Type	Description
		GP	GA, TB			
RC Oscillation Monitor	P4.3/ MON	29	27	27	O	Secondary functions of P4.3: This pin is a monitor output of the RC oscillation clock for an A/D converter and a 700kHz RC oscillation clock for a system clock.
Battery Check	P0.3/ CMP	80	78	78	I	Secondary functions of P0.3: This pin is an analog comparator input pin for battery check circuit.

MEMORY MAPS

Program Memory

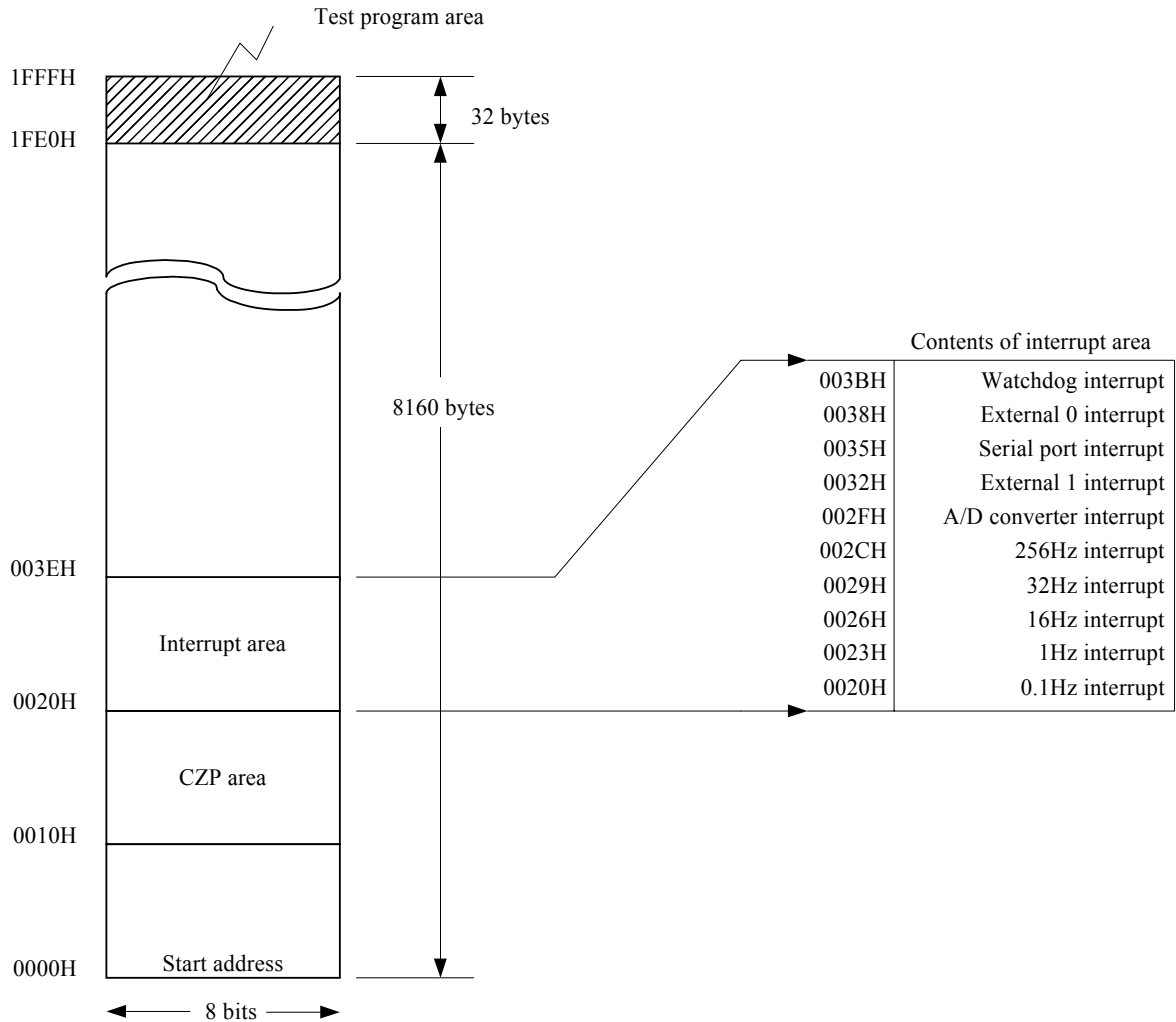

Program Memory Map

Address 0000H is the instruction execution start address by the system reset.

The CZP area from address 0010H to address 001FH is the start address for the CZP subroutine of 1-byte call instruction.

The start address of interrupt subroutine is assigned to the interrupt address from address 0020H to 003DH.

The user area has 8160 bytes of address 0000H to 1FDFH. No program can be stored in the test program area.

Data Memory

The data memory area consists of 8 banks and each bank has 256 nibbles (256 × 4 bits).
 The data RAM is assigned to BANK 6, BANK 7 and peripheral ports are assigned to BANK 0.

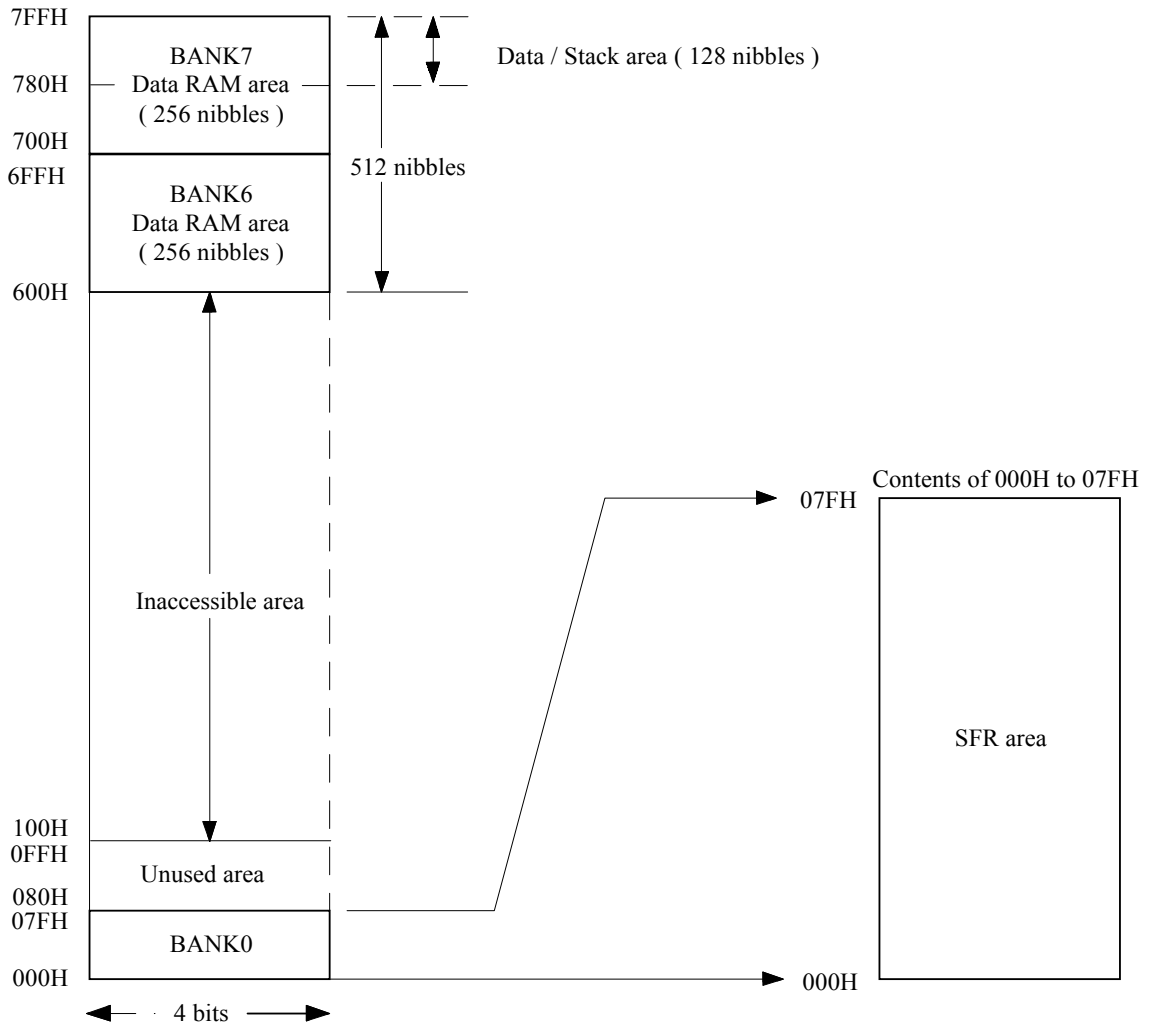

Data Memory Map

Half the BANK 7 of Data RAM area (128 nibbles) is shared by the stack area. The stack is a memory starting from address 7FFH toward the low-order addresses where 4 nibbles are used by Subroutine Call Instruction and 8 nibbles are used by an interrupt.

The addresses 080H to 0FFH of BANK 0 are not assigned as the data memory, so access to these addresses has no effect. Moreover, it is impossible to access BANK 1 to BANK 5.

ABSOLUTE MAXIMUM RATINGS (1.5 V Spec.)(V_{SS} = 0 V)

Parameter	Symbol	Condition	Rating	Unit
Power supply voltage 1	V _{DD1}	T _a = 25°C	-0.3 to + 2.0	V
Power supply voltage 2	V _{DD2}	T _a = 25°C	-0.3 to + 4.0	V
Power supply voltage 3	V _{DD3}	T _a = 25°C	-0.3 to + 5.5	V
Power supply voltage 4	V _{DDL}	T _a = 25°C	-0.3 to + 2.0	V
Power supply voltage 5	V _{DDI}	T _a = 25°C	-0.3 to + 5.5	V
Power supply voltage 6	V _{DD}	T _a = 25°C	-0.3 to + 2.0	V
Input voltage 1	V _{IN1}	V _{DD} input, T _a = 25°C	-0.3 to V _{DD} + 0.3	V
Input voltage 2	V _{IN2}	V _{DDI} input, T _a = 25°C	-0.3 to V _{DDI} + 0.3	V
Input voltage 3	V _{IN3}	V _{DDL} input, T _a = 25°C	-0.3 to V _{DDL} + 0.3	V
Output voltage 1	V _{OUT1}	V _{DD1} output, T _a = 25°C	-0.3 to V _{DD1} + 0.3	V
Output voltage 2	V _{OUT2}	V _{DD2} output, T _a = 25°C	-0.3 to V _{DD2} + 0.3	V
Output voltage 3	V _{OUT3}	V _{DD3} output, T _a = 25°C	-0.3 to V _{DD3} + 0.3	V
Output voltage 4	V _{OUT4}	V _{DD} output, T _a = 25°C	-0.3 to V _{DD} + 0.3	V
Output voltage 5	V _{OUT5}	V _{DDL} output, T _a = 25°C	-0.3 to V _{DDL} + 0.3	V
Output voltage 6	V _{OUT6}	V _{DDI} output, T _a = 25°C	-0.3 to V _{DDI} + 0.3	V
Power Dissipation	PD	T _a = -40 to + 85°C QFP80-P-1420-0.80-BK	191	mW
		T _a = -40 to + 85°C QFP80-P-1414-0.65-K	167	mW
		T _a = -40 to + 85°C TQFP80-P-1212-0.50-K	149	mW
Storage temperature	T _{STG}	-	-55 to + 150	°C

RECOMMENDED OPERATING CONDITIONS (1.5V Spec.)(V_{SS} = 0V)

Parameter	Symbol	Condition	Rating	Unit
Operating Temperature*	T _{OP}	-	-40 to + 85	°C
Operating Voltage*	V _{DD}	-	1.25 to 1.7	V
	V _{DDI}	-	V _{DD} to 5.25	V
External 700kHz RC Oscillator Resistance*	R _{OS}	-	60 to 200	kΩ
Crystal oscillation frequency*	f _{XT}	-	30 to 35	kHz

* : At Non-regulated LCD driver.

In case of select a voltage regulated LCD driver, see P.38/49.

ELECTRICAL CHARACTERISTICS (1.5 V Spec.)**DC Characteristics (1.5 V Spec.)**

(VSS=0V, VDD1=VDDI=VDD=1.5V, Ta=-40 to +85°C unless otherwise specified)

Parameter	Symbol	Condition	Min.	Typ.	Max.	Unit	Measuring Circuit
VDD2 Voltage*	VDD2	Ca, Cb, C12=0.1μF +100% -50%	2.8	3.0	3.2	V	1
VDD3 Voltage*	VDD3	Ca, Cb, C12=0.1μF +100% -50%	4.3	4.5	4.7	V	
VDDL Voltage	VDDL	-	0.6	1.4	1.5	V	
Crystal Oscillation Start Voltage	VSTA	Oscillation start time: within 5 seconds	1.45	-	-	V	
Crystal Oscillation Hold Voltage	VHOLD	-	1.25	-	-	V	
Crystal Oscillation Stop Detection Time	TSTOP	-	0.1	-	1000	ms	
Internal Crystal Oscillator Capacitance	CG	-	10	15	20	pF	
External Crystal Oscillator Capacitance	CGEX	When external CG used	10	-	30	pF	
Internal Crystal Oscillator Capacitance	CD	-	10	15	20	pF	
Internal 700kHz RC Oscillator Capacitance	COS	-	8	12	16	pF	
700kHz RC Oscillation Frequency	fOSC	External resistor ROS=160kΩ VDD1 = 1.25 to 1.7V	80	280	350	kHz	
POR Generation Voltage	VPOR1	When VDD is between VPOR1 and 1.5V	0	-	0.4	V	
POR Non-generation Voltage	VPOR2	No POR when VDD is between VPOR2 and 1.5V	1.2	-	1.5	V	
Battery Check Reference Voltage	VRB	Ta = 25°C	0.50	0.60	0.70	V	
VRB Temperature Variation	ΔVRB	-	-	-2	-	mV/°C	

Notes: 1."POR" denotes Power On Reset.

2."TSTOP" indicates that if the crystal oscillator stops over the value of TSTOP, the system reset occurs.

* : At Non-regulated LCD driver.

In case of select a voltage regulated LCD driver, see P.38/49.

DC Characteristics (1.5 V Spec.) (Continued)(V_{SS}=0V, V_{DD1}=V_{DDI}=V_{DD}=1.5V, Ta=-40 to +85°C unless otherwise specified)

Parameter	Symbol	Condition	Min.	Typ.	Max	Unit	Measuring Circuit	
Supply current 1*	I _{DD1}	CPU in halt state (700kHz RC oscillation stop)	-	2	5	μA	1	
Supply current 2*	I _{DD2}	CPU in operating state (700kHz RC oscillation stop)	-	5	15	μA		
Supply current 3	I _{DD3}	CPU in operating state (700kHz RC oscillation in operation)	-	60	100	μA		
Supply current 4	I _{DD4}	Serial transfer, f _{SCK} =300kHz, CPU in operating state (700kHz RC oscillation stop)	-	7	50	μA		
Supply current 5	I _{DD5}	CPU in halt state (700kHz RC oscillation stop)	R _{T0} =10kΩ	-	150	230		μA
		RC oscillation for A/D converter is in operating state	R _{T0} =2kΩ	-	600	900		μA
Supply current 6	I _{DD6}	Battery check circuit in operating state, CPU in operating state (700kHz RC oscillation stop)	-	10	80	μA		

* : At Non-regulated LCD driver.

In case of select a voltage regulated LCD driver, see P.38/49.

DC Characteristics (1.5 V Spec.) (Continued)

(VSS=0V, VDD1=VDDI=VDD=1.5V, VDD2=3.0V, VDD3=4.5V, Ta=-40 to +85°C unless otherwise specified)

Parameter	Symbol	Condition	Min.	Typ.	Max.	Unit	Measuring Circuit
Output current 1 (P1.0)	IOH1	VOH1 = VDDI - 0.5V	-2.1	-0.7	-0.2	mA	2
	IOL1	VOL1 = 0.5V	1	3	9		
	IOH1S	VDDI = 5.0V, VOH1S = VDDI - 0.5V	-9	-3	-1		
	IOL1S	VDDI = 5.0V, VOL1S = 0.5V	4	8	20		
Output current 2 (P1.1 to P1.3) (P2.0 to P2.3) (P3.0 to P3.3) (P4.0 to P4.3)	IOH2	VOH2 = VDDI - 0.5V	-2.1	-0.7	-0.2		
	IOL2	VOL2 = 0.5V	0.2	0.7	2.1		
	IOH2S	VDDI = 5.0V, VOH2S = VDDI - 0.5V	-9	-3	-1		
	IOL2S	VDDI = 5.0V, VOL2S = 0.5V	1	3	9		
Output current 3 (BD)	IOH3	VOH3 = VDD - 0.7V	-1.8	-0.6	-0.1		
	IOL3	VOL3 = 0.7V	0.2	2.0	4.0		
Output current 4 (RT0, RT1, RS0, RS1, CRT0, CS0, CS1)	IOH4	VOH4 = VDD - 0.1V	-1.1	-0.6	-0.2		
	IOL4	VOL4 = 0.1V	0.3	0.6	1.1		
Output current 5 (When the pins L26 to L33 are configured as output ports)	IOH5	VOH5 = VDDI - 0.5V	-1.5	-0.5	-0.1		
	IOL5	VOL5 = 0.5V	0.1	0.5	1.5		
	IOH5S	VDDI = 5V, VOH5S = VDDI-0.5V	-2.0	-1	-0.2		
	IOL5S	VDDI=5V, VOL5S=0.5V	0.2	1	2.0		
Output current 6 (OSC2)	IOH6	VOH6=VDD-0.5V	-2.1	-0.7	-0.15		
	IOL6	VOL6=0.5V	0.15	0.7	2.1		
Output current 7 (L0 to L33)	IOH7	VOH7 = VDD3 - 0.2V (VDD3 level)	-	-	-4	μA	-
	IOMH7	VOMH7 = VDD2 + 0.2V (VDD2 level)	4	-	-		
	IOMH7S	VOMH7S = VDD2 - 0.2V (VDD2 level)	-	-	-4		
	IOML7	VOML7 = VDD1 + 0.2V (VDD1 level)	4	-	-		
	IOML7S	VOML7S = VDD1 - 0.2V (VDD1 level)	-	-	-4		
	IOL7	VOL7 = VSS + 0.2V (VSS level)	4	-	-		
Output Leakage Current (P1.0 to P1.3) (P2.0 to P2.3) (P3.0 to P3.3) (P4.0 to P4.3) (RT0, RT1, RS0, RS1, CRT0, CS0, CS1)	IOOH	VOH = VDD	-	-	0.3		
	IOL	VOL = VSS	-0.3	-	-		

DC Characteristics (1.5 V Spec.) (Continued)

(VSS=0V, VDD1=VDDI=VDD=1.5V, VDD2=3.0V, VDD3=4.5V, Ta=-40 to +85°C unless otherwise specified)

Parameter	Symbol	Condition	Min.	Typ.	Max.	Unit	Measuring Circuit
Input Current 1 (P0.0 to P0.3) (P2.0 to P2.3) (P3.0 to P3.3) (P4.0 to P4.3)	I _{IH1}	V _{IH1} = V _{DDI} (when pulled down)	2	10	60	μA	3
	I _{IL1}	V _{IL1} =V _{SS} (when pulled up)	-60	-10	-3		
	I _{IH1S}	V _{IH1} =V _{DDI} =5V (when pulled down)	70	250	660		
	I _{IL1S}	V _{IL1} =V _{SS} , V _{DDI} =5V (when pulled up)	-660	-250	-70		
	I _{IH1Z}	V _{IH1} =V _{DDI} (in a high impedance)	0	-	1		
	I _{IL1Z}	V _{IL1} =V _{SS} (in a high impedance)	-1	-	0		
Input Current 2 (IN0, IN1)	I _{IH2}	V _{IH2} =V _{DD} (when pulled down)	2	8	60		
	I _{IH2Z}	V _{IH2} =V _{DD} (in a high impedance)	0	-	1		
	I _{IL2Z}	V _{IL2} =V _{SS} (in a high impedance)	-1	-	0		
Input Current 3 (OSC1)	I _{IL3}	V _{IL3} =V _{SS} (when pulled up)	-60	-18	-5		
	I _{IH3Z}	V _{IH3} =V _{DD} (in a high impedance)	0	-	1		
	I _{IL3Z}	V _{IL3} =V _{SS} (in a high impedance)	-1	-	0		
Input Current 4 (RESET, TST1, TST2)	I _{IH4}	V _{IH} =V _{DD}	0	-	1		
	I _{IL4}	V _{IL4} =V _{SS}	-1.0	-0.3	-0.05		
Input Voltage 1 (P0.0 to P0.3) (P2.0 to P2.3) (P3.0 to P3.3) (P4.0 to P4.3)	V _{IH1}	-	1.2	-	1.5	V	4
	V _{IL1}	-	0	-	0.3		
	V _{IH1S}	V _{DDI} =5.0V	4	-	5		
	V _{IL1S}	V _{DDI} =5.0V	0	-	1		
Input Voltage 2 (IN0, IN1, OSC1)	V _{IH2}	-	1.2	-	1.5		
	V _{IL2}	-	0	-	0.3		
Input Voltage 3 (RESET, TST1, TST2)	V _{IH3}	-	1.2	-	1.5		
	V _{IL3}	-	0	-	0.3		

DC Characteristics (1.5 V Spec.) (Continued)

(VSS=0V, VDD1=VDDI=VDD=1.5V, VDD2=3.0V, VDD3=4.5V, Ta=-40 to +85°C unless otherwise specified)

Parameter	Symbol	Condition	Min.	Typ.	Max.	Unit	Measuring Circuit
Hysteresis Width (P0.0 to P0.3) (P2.0 to P2.3) (P3.0 to P3.3) (P4.0 to P4.3)	ΔV_{T1}	-	0.05	0.1	0.3	V	4
	ΔV_{T1S}	VDDI=5.0V	0.25	1.0	1.5		
Hysteresis Width (RESET, TST1, TST2)	ΔV_{T2}	-	0.05	0.1	0.3		
Input Pin Capacitance (P0.0 to P0.3) (P2.0 to P2.3) (P3.0 to P3.3) (P4.0 to P4.3)	C _{IN}	-	-	-	5	pF	1

Measuring circuit 1

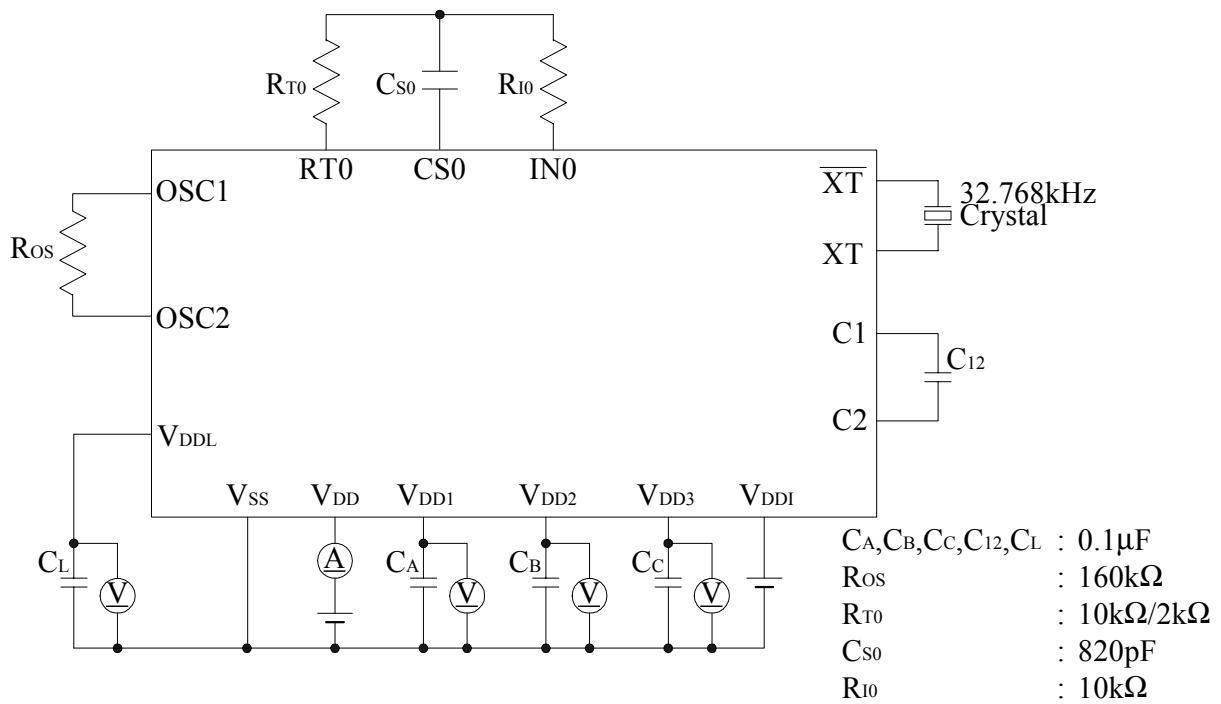

Measuring circuit 2

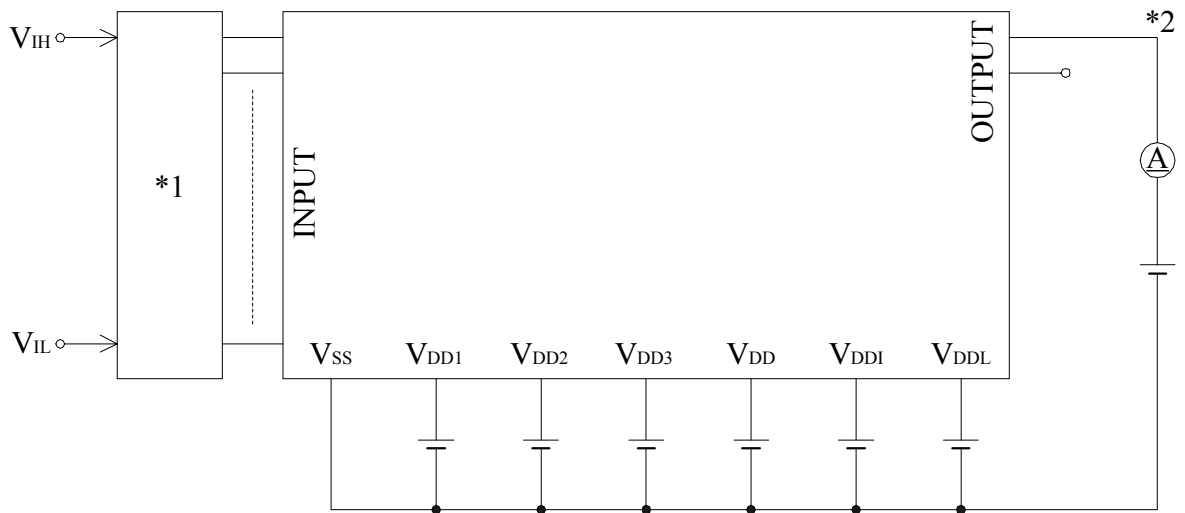

Measuring circuit 3

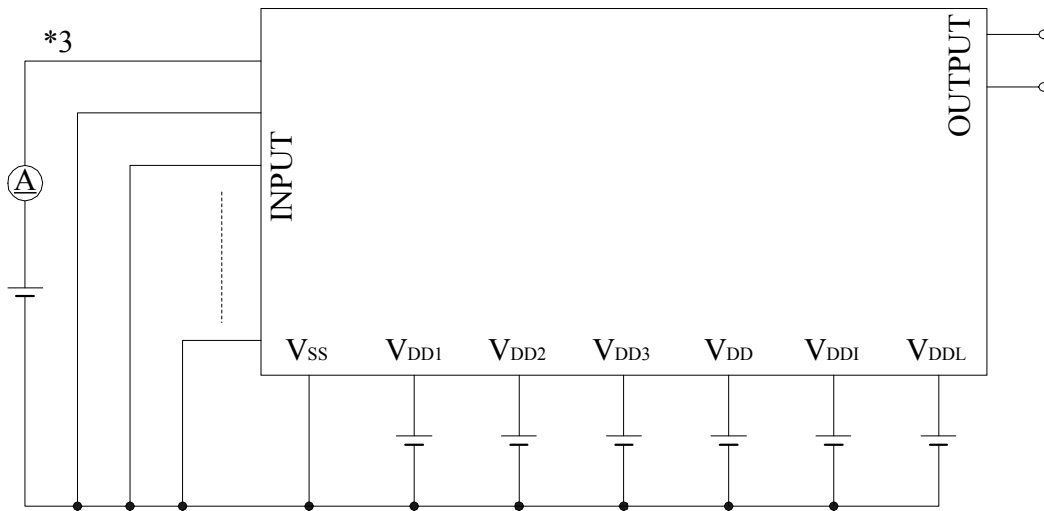

Measuring circuit 4

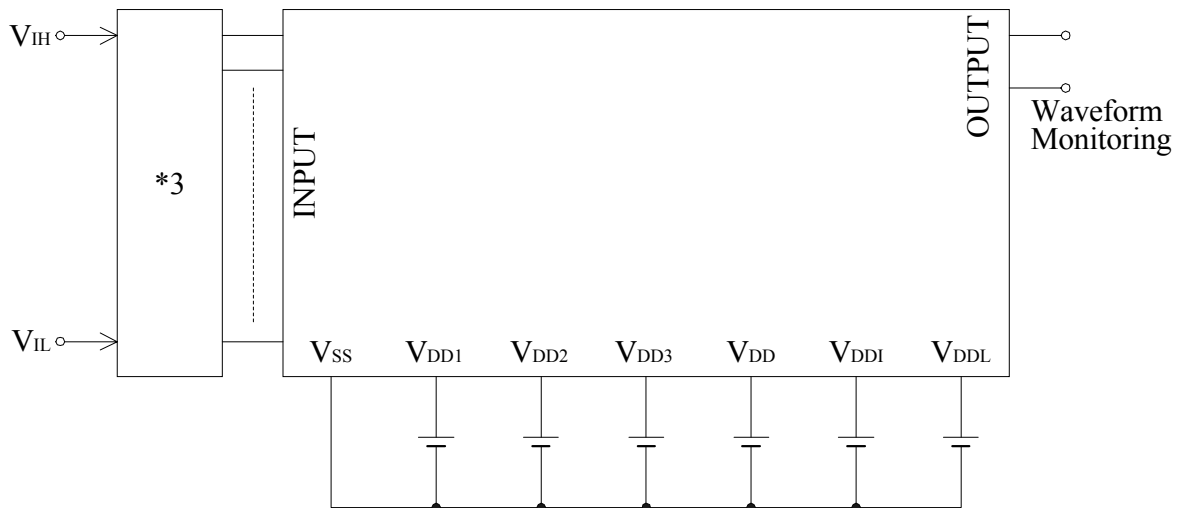

- *1 Input logic circuit to determine the specified measuring conditions.
- *2 Measured at the specified output pins.
- *3 Measured at the specified input pins.

A/D Converter Characteristics (1.5V Spec.)

(VSS=0V, VDD1=VDDI=VDD=1.5V, Ta=-40 to +85°C unless otherwise specified)

Parameter	Symbol	Condition	Min.	Typ.	Max.	Unit	Measuring Circuit
Resistor for Oscillation	RS0, RS1, RT0, RT0-1, RT1	CS0, CT0, CS1 ≥ 740pF	2	-	-	kΩ	5
Input Current Limiting Resistor	RT0, RT1	-	1	10	-	kΩ	
Oscillation Frequency	fOSC1	Resistor for oscillation =2 kΩ	165	221	256	kHz	
	fOSC2	Resistor for oscillation =10 kΩ	41.8	52.2	60.6	kHz	
	fOSC3	Resistor for oscillation =200 kΩ	2.55	3.04	3.53	kHz	
RS•RT Oscillation Frequency Ratio (*)	Kf1	RT0, RT0-1, RT1 = 2 kΩ	3.89	4.18	4.35	-	
	Kf2	RT0, RT0-1, RT1 = 10 kΩ	0.990	1.000	1.010	-	
	Kf3	RT0, RT0-1, RT1 = 200 kΩ	0.0561	0.0584	0.0637	-	

* Kfx is the ratio of the oscillation frequency by a sensor resistor to the oscillation frequency by a reference resistor in the same condition.

$$Kf_x = \frac{f_{OSC_x}(RT_0 - CS_0 \text{ Oscillation})}{f_{OSC_x}(RS_0 - CS_0 \text{ Oscillation})}, \quad \frac{f_{OSC_x}(RT_0-1 - CS_0 \text{ Oscillation})}{f_{OSC_x}(RS_0 - CS_0 \text{ Oscillation})}, \quad \frac{f_{OSC_x}(RT_1 - CS_1 \text{ Oscillation})}{f_{OSC_x}(RS_1 - CS_1 \text{ Oscillation})}$$

(x = 1, 2, 3)

Measuring circuit 5

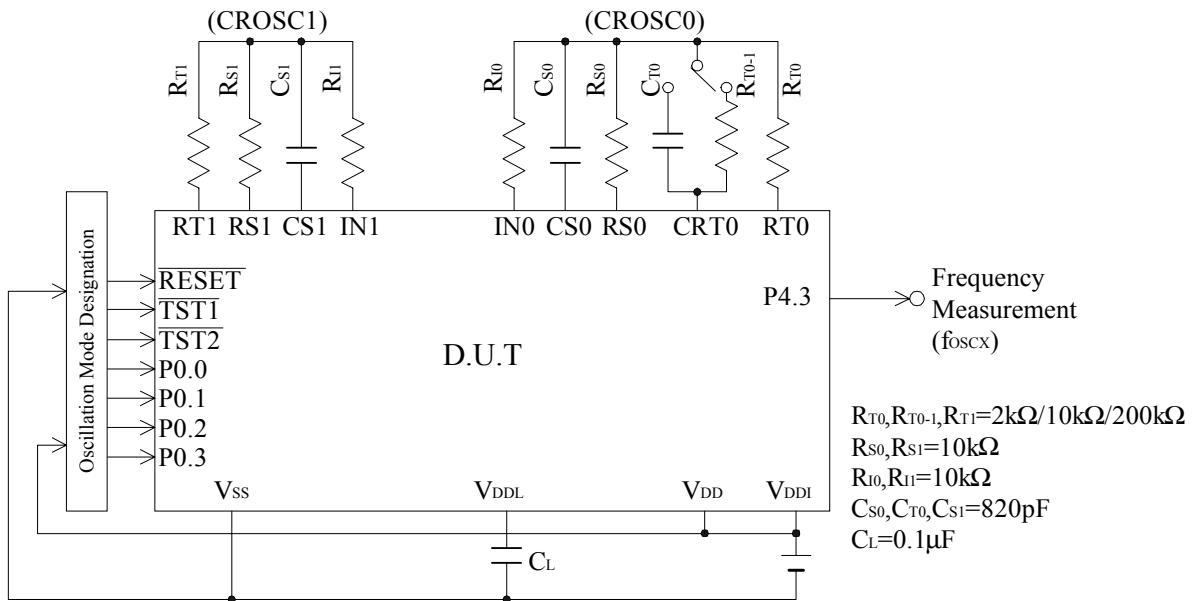

AC Characteristics (1.5 V Spec.) (Serial Interface)

(VSS=0v, VDDI=5.0V, VDD=1.5V , Ta=-40 to +85°C unless otherwise specified)

Parameter	Symbol	Condition	Min.	Typ.	Max.	Unit
SCLK Input Fall Time	t_f	-	-	15	50	ns
SCLK Input Rise Time	t_r	-	-	15	50	ns
SCLK Input “L” Level Pulse Width	t_{CWL}	-	0.8	-	-	μ s
SCLK Input “H” Level Pulse Width	t_{CWH}	-	0.8	-	-	μ s
SCLK Input Cycle Time	t_{CYC}	-	2.0	-	-	μ s
SCLK Output Cycle Time	$t_{CYC1(O)}$	CPU is operating at 32.768kHz	-	30.5	-	μ s
SCLK Output Cycle Time	$t_{CYC2(O)}$	CPU is operating at 700kHz	-	1.43	-	μ s
SOUT Output Delay Time	t_{DDR}	$C_L=10pF$	-	-	0.4	μ s
SIN Input Setup Time	t_{DS}	-	0.5	-	-	μ s
SIN Input Hold Time	t_{DH}	-	0.8	-	-	μ s

Synchronous communication timing

(“H” level = 4.0V, “L” level = 1.0V)

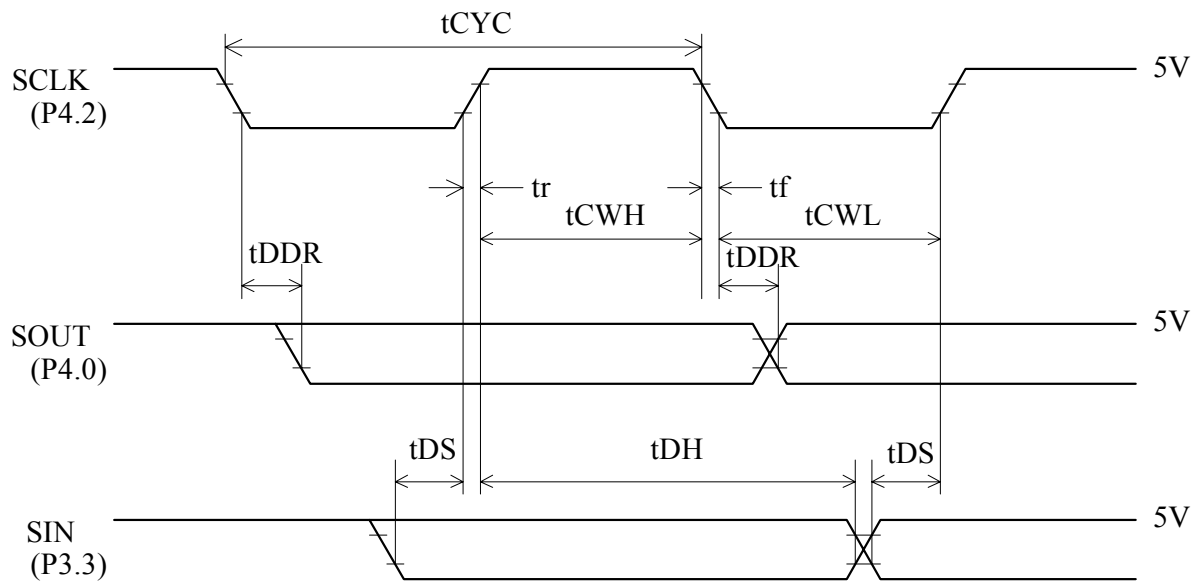

ABSOLUTE MAXIMUM RATINGS (3.0 V Spec.)(V_{SS} = 0V)

Parameter	Symbol	Condition	Rating	Unit
Power supply voltage 1	V _{DD1}	T _a = 25°C	-0.3 to + 2.0	V
Power supply voltage 2	V _{DD2}	T _a = 25°C	-0.3 to + 4.0	V
Power supply voltage 3	V _{DD3}	T _a = 25°C	-0.3 to + 5.5	V
Power supply voltage 4	V _{DDL}	T _a = 25°C	-0.3 to + 2.0	V
Power supply voltage 5	V _{DDI}	T _a = 25°C	-0.3 to + 5.5	V
Power supply voltage 6	V _{DD}	T _a = 25°C	-0.3 to + 2.0	V
Input voltage 1	V _{IN1}	V _{DD} input, T _a = 25°C	-0.3 to V _{DD} + 0.3	V
Input voltage 2	V _{IN2}	V _{DDI} input, T _a = 25°C	-0.3 to V _{DDI} + 0.3	V
Input voltage 3	V _{IN3}	V _{DDL} input, T _a = 25°C	-0.3 to V _{DDL} + 0.3	V
Output voltage 1	V _{OUT1}	V _{DD1} output, T _a = 25°C	-0.3 to V _{DD1} + 0.3	V
Output voltage 2	V _{OUT2}	V _{DD2} output, T _a = 25°C	-0.3 to V _{DD2} + 0.3	V
Output voltage 3	V _{OUT3}	V _{DD3} output, T _a = 25°C	-0.3 to V _{DD3} + 0.3	V
Output voltage 4	V _{OUT4}	V _{DD} output, T _a = 25°C	-0.3 to V _{DD} + 0.3	V
Output voltage 5	V _{OUT5}	V _{DDL} output, T _a = 25°C	-0.3 to V _{DDL} + 0.3	V
Output voltage 6	V _{OUT6}	V _{DDI} output, T _a = 25°C	-0.3 to V _{DDI} + 0.3	V
Power Dissipation	PD	T _a = -40 to + 85°C QFP80-P-1420-0.80-BK	191	mW
		T _a = -40 to + 85°C QFP80-P-1414-0.65-K	167	mW
		T _a = -40 to + 85°C TQFP80-P-1212-0.50-K	149	mW
Storage temperature	T _{STG}	-	-55 to + 150	°C

RECOMMENDED OPERATING CONDITIONS (3.0V Spec.)(V_{SS} = 0V)

Parameter	Symbol	Condition	Rating	Unit
Operating Temperature*1	T _{OP}	-	-40 to + 85	°C
Operating Voltage*1	V _{DD}	Using LCD driver with "duty 1/2"	2.2 to 3.5	V
		Except using LCD driver with "duty 1/2"	2.0 to 3.5	V
	V _{DDI}	-	V _{DD} to 5.25	V
External 700kHz RC oscillator Resistance*1	R _{OS}	-	60 to 200	kΩ
Crystal oscillation frequency*1	f _{XT}	-	30 to 66	kHz

*1: At Non-regulated LCD driver.

In case of select a voltage regulated LCD driver, see P.38/49.

ELECTRICAL CHARACTERISTICS (3.0 V Spec.)

DC Characteristics (3.0 V Spec.)

(V_{SS}=0V, V_{DD2}=V_{DD1}=V_{DD}=3.0V, T_a=-40 to +85°C unless otherwise specified)

Parameter	Symbol	Condition	Min.	Typ.	Max.	Unit	Measuring Circuit
VDD1 Voltage*	VDD1	Ca, Cb, C12=0.1μF +100% -50%	1.3	1.5	1.7	V	1
VDD3 Voltage*	VDD3	Ca, Cb, C12=0.1μF +100% -50%	4.3	4.5	4.7	V	
VDDL Voltage	VDDL	-	0.6	1.4	2.0	V	
Crystal Oscillation Start Voltage	VSTA	Oscillation start time: within 5 seconds	2.0	-	-	V	
Crystal Oscillation Hold Voltage	VHOLD	-	2.0	-	-	V	
Crystal Oscillation Stop Detection Time	TSTOP	-	0.1	-	1000	ms	
Internal Crystal Oscillator Capacitance	CG	-	10	15	20	pF	
External Crystal Oscillator Capacitance	CGEX	When external CG used	10	-	30	pF	
Internal Crystal Oscillator Capacitance	CD	-	10	15	20	pF	
Internal 700kHz RC Oscillator Capacitance	COS	-	8	12	16	pF	
700kHz RC Oscillation Frequency	fOSC	External resistor ROS=60kΩ VDD2 = 2.0 to 3.5V	600	700	1000	kHz	
POR Generation Voltage	VPOR1	When VDD2 is between VPOR1 and 3.0V	0	-	0.7	V	
POR Non-generation Voltage	VPOR2	No POR when VDD2 is between VPOR2 and 3.0V	2	-	3	V	
Battery Check Reference Voltage	VRB	T _a = 25°C	0.50	0.60	0.70	V	
VRB Temperature Variation	ΔVRB		-	-2	-	mV/°C	

- Notes: 1."POR" denotes Power On Reset.
 2."TSTOP" indicates that if the crystal oscillator stops over the value of TSTOP, the system reset occurs.
 *: At Non-regulated LCD driver.
 In case of select a voltage regulated LCD driver, see P.38/49.

DC Characteristics (3.0 V Spec.) (Continued)(V_{SS}=0V, V_{DD2}=V_{DD1}=V_{DD}=3.0V, T_a=-40 to +85°C unless otherwise specified)

Parameter	Symbol	Condition	Min.	Typ.	Max.	Unit	Measuring Circuit	
Supply current 1*	I _{DD1}	CPU in halt state (700kHz RC oscillation stop)	-	2	5	μA	1	
Supply current 2*	I _{DD2}	CPU in operating state (700kHz RC oscillation stop)	-	5	15	μA		
Supply current 3	I _{DD3}	CPU in operating state (700kHz RC oscillation in operation)	-	400	800	μA		
Supply current 4	I _{DD4}	Serial transfer, f _{SCK} =300kHz, CPU in operating state (700kHz RC oscillation stop)	-	7	50	μA		
Supply current 5	I _{DD5}	CPU in halt state (700kHz RC oscillation stop)	R _{T0} =10kΩ	-	300	450		μA
		RC oscillation for A/D converter is in operating state	R _{T0} =2kΩ	-	1300	2000		μA
Supply current 6	I _{DD6}	Battery check circuit in operating state, CPU in operating state (700kHz RC oscillation stop)	-	15	100	μA		

*: At Non-regulated LCD driver.

In case of select a voltage regulated LCD driver, see P.38/49.

DC Characteristics (3.0 V Spec.) (Continued)

(VSS=0V, VDD1=1.5V, VDD2=VDDI=VDD=3.0V, VDD3=4.5V, Ta=-40 to +85°C unless otherwise specified)

Parameter	Symbol	Condition	Min.	Typ.	Max.	Unit	Measuring Circuit
Output current 1 (P1.0)	IOH1	VOH1 = VDD1 - 0.5V	-6.0	-2.0	-0.7	mA	2
	IOL1	VOL1 = 0.5V	2	5	20		
	IOH1S	VDD1 = 5.0V, VOH1S = VDD1 - 0.5V	-9	-3	-1		
	IOL1S	VDD1 = 5.0V, VOL1S = 0.5V	4	8	25		
Output current 2 (P1.1 to P1.3) (P2.0 to P2.3) (P3.0 to P3.3) (P4.0 to P4.3)	IOH2	VOH2 = VDD1 - 0.5V	-6.0	-2.0	-0.7		
	IOL2	VOL2 = 0.5V	0.7	2.0	6.0		
	IOH2S	VDD1 = 5.0V, VOH2S = VDD1 - 0.5V	-9	-3	-1		
	IOL2S	VDD1 = 5.0V, VOL2S = 0.5V	1	3	9		
Output current 3 (BD)	IOH3	VOH3 = VDD - 0.7V	-6.0	-2.0	-0.7		
	IOL3	VOL3 = 0.7V	0.7	6.0	10.0		
Output current 4 (RT0, RT1, RS0, RS1, CRT0, CS0, CS1)	IOH4	VOH4 = VDD - 0.1V	-2.5	-0.8	-0.3		
	IOL4	VOL4 = 0.1V	0.7	1.3	2.5		
Output current 5 (When the pins L26 to L33 are configured as output ports)	IOH5	VOH5 = VDD1 - 0.5V	-1.5	-0.8	-0.15		
	IOL5	VOL5 = 0.5V	0.15	1.0	4.0		
	IOH5S	VDD1 = 5V, VOH5S = VDD1 - 0.5V	-2.0	-1.0	-0.2		
	IOL5S	VDD1 = 5V, VOL5S = 0.5V	0.2	1.0	5.0		
Output current 6 (OSC2)	IOH6	VOH6 = VDD - 0.5V	-4.0	-0.8	-0.3		
	IOL6	VOL6 = 0.5V	0.7	2.0	6.0		
Output current 7 (L0 to L33)	IOH7	VOH7 = VDD3 - 0.2V (VDD3 level)	-	-	-4	μA	-
	IOMH7	VOMH7 = VDD2 + 0.2V (VDD2 level)	4	-	-		
	IOMH7S	VOMH7S = VDD2 - 0.2V (VDD2 level)	-	-	-4		
	IOML7	VOML7 = VDD1 + 0.2V (VDD1 level)	4	-	-		
	IOML7S	VOML7S = VDD1 - 0.2V (VDD1 level)	-	-	-4		
	IOL7	VOL7 = VSS + 0.2V (VSS level)	4	-	-		
Output Leakage Current (P1.0 to P1.3) (P2.0 to P2.3) (P3.0 to P3.3) (P4.0 to P4.3) (RT0, RT1, RS0, RS1, CRT0, CS0, CS1)	IOOH	VOH = VDD	-	-	0.3		
	IOL	VOL = VSS	-0.3	-	-		

DC Characteristics (3.0 V Spec.) (Continued)

(VSS=0V, VDD1=1.5V, VDD2=VDDI=VDD=3.0V, VDD3=4.5V, Ta=-40 to +85°C unless otherwise specified)

Parameter	Symbol	Condition	Min.	Typ.	Max.	Unit	Measuring Circuit
Input Current 1 (P0.0 to P0.3) (P2.0 to P2.3) (P3.0 to P3.3) (P4.0 to P4.3)	I _{IH1}	V _{IH1} = V _{DDI} (when pulled down)	30	90	300	μA	3
	I _{IL1}	V _{IL1} =V _{SS} (when pulled up)	-300	-90	-30		
	I _{IH1S}	V _{IH1} =V _{DDI} =5V (when pulled down)	80	250	800		
	I _{IL1S}	V _{IL1} =V _{SS} , V _{DDI} =5V (when pulled up)	-800	-250	-80		
	I _{IH1Z}	V _{IH1} =V _{DDI} (in a high impedance)	0	-	1		
	I _{IL1Z}	V _{IL1} =V _{SS} (in a high impedance)	-1	-	0		
Input Current 2 (IN0, IN1)	I _{IH2}	V _{IH2} =V _{DD} (when pulled down)	30	90	300		
	I _{IH2Z}	V _{IH2} =V _{DD} (in a high impedance)	0	-	1		
	I _{IL2Z}	V _{IL2} =V _{SS} (in a high impedance)	-1	-	0		
Input Current 3 (OSC1)	I _{IL3}	V _{IL3} =V _{SS} (when pulled up)	-300	-110	-10		
	I _{IH3Z}	V _{IH3} =V _{DD} (in a high impedance)	0	-	1		
	I _{IL3Z}	V _{IL3} =V _{SS} (in a high impedance)	-1	-	0		
Input Current 4 (RESET, TST1, TST2)	I _{IH4}	V _{IH4} =V _{DD}	0	-	1	mA	
	I _{IL4}	V _{IL4} =V _{SS}	-3.00	-1.50	-0.75		
Input Voltage 1 (P0.0 to P0.3) (P2.0 to P2.3) (P3.0 to P3.3) (P4.0 to P4.3)	V _{IH1}	-	2.4	-	3.0	V	4
	V _{IL1}	-	0	-	0.6		
	V _{IH1S}	V _{DDI} =5.0V	4	-	5		
	V _{IL1S}	V _{DDI} =5.0V	0	-	1		
Input Voltage 2 (IN0, IN1, OSC1)	V _{IH2}	-	2.4	-	3.0		
	V _{IL2}	-	0	-	0.6		
Input Voltage 3 (RESET, TST1, TST2)	V _{IH3}	-	2.4	-	3.0		
	V _{IL3}	-	0	-	0.6		

DC Characteristics (3.0V Spec.) (Continued)(V_{SS}=0V, V_{DD1}=1.5V, V_{DD2}=V_{DDI}=V_{DD}=3.0V, V_{DD3}=4.5V, Ta=-40 to +85°C unless otherwise specified)

Parameter	Symbol	Condition	Min.	Typ.	Max.	Unit	Measuring Circuit
Hysteresis Width (P0.0 to P0.3) (P2.0 to P2.3) (P3.0 to P3.3) (P4.0 to P4.3)	ΔV_{T1}	-	0.2	0.5	1.0	V	4
	ΔV_{T1S}	V _{DDI} =5.0V	0.25	1.00	1.50		
Hysteresis Width (RESET, TST1, TST2)	ΔV_{T2}	-	0.2	0.5	1.0		
Input Pin Capacitance (P0.0 to P0.3) (P2.0 to P2.3) (P3.0 to P3.3) (P4.0 to P4.3)	C _{IN}	-	-	-	5	pF	1

Measuring circuit 1

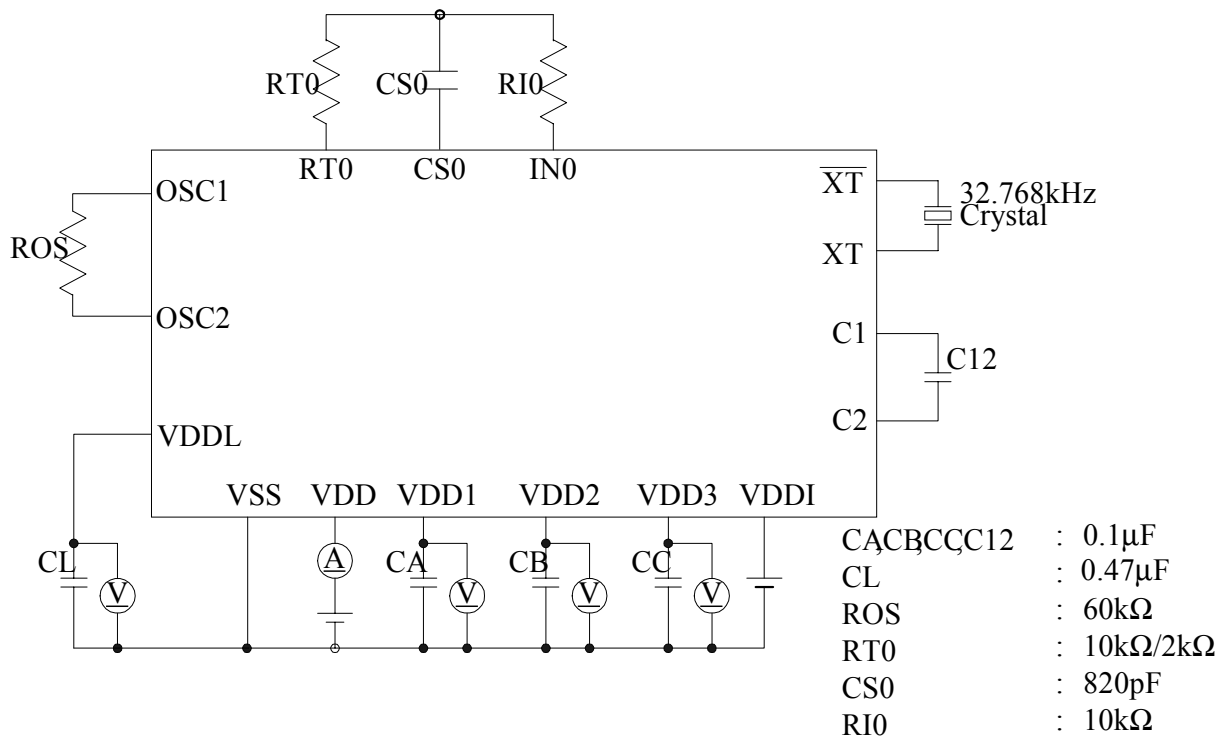

Measuring circuit 2

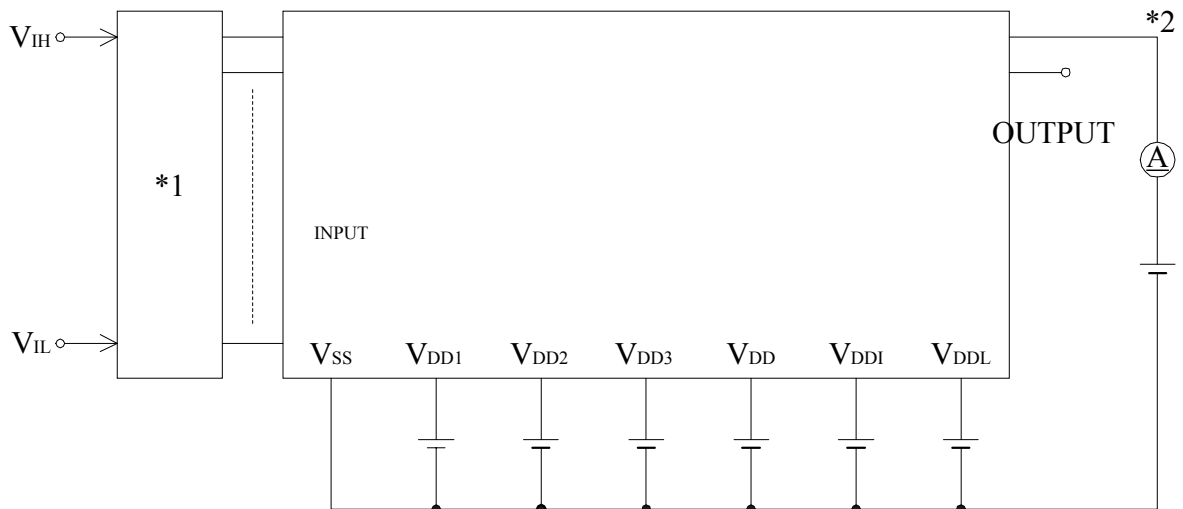

Measuring circuit 3

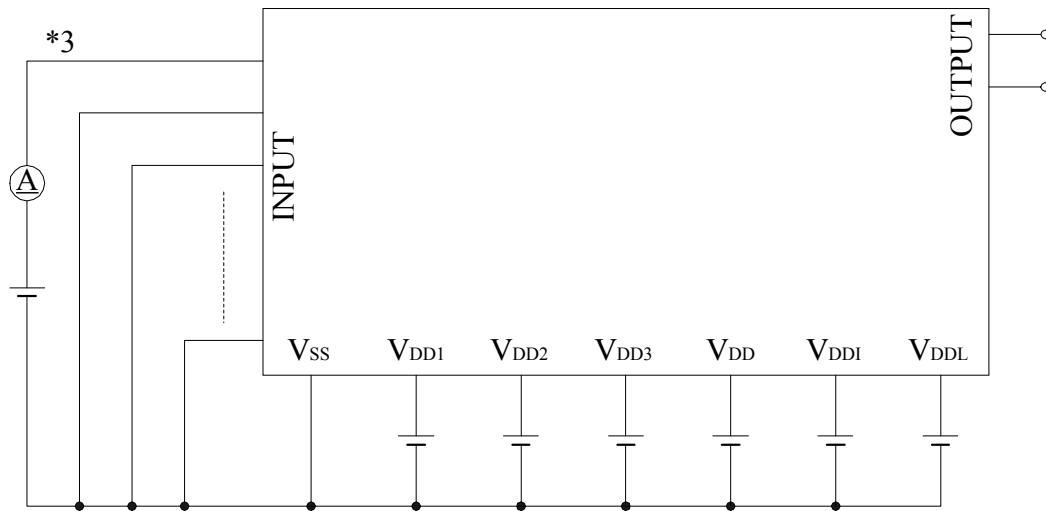

Measuring circuit 4

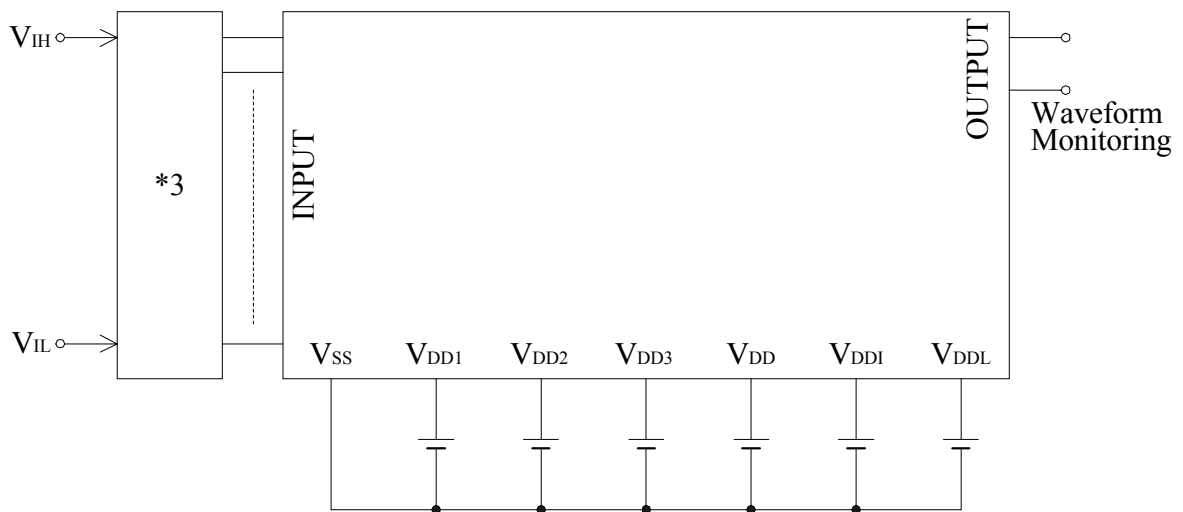

- *1 Input logic circuit to determine the specified measuring conditions.
- *2 Measured at the specified output pins.
- *3 Measured at the specified input pins.

A/D Converter Characteristics (3.0 V Spec.)

(V_{SS}=0V, V_{DD2}=V_{DD}=3.0V, T_a=-40 to +85°C unless otherwise specified)

Parameter	Symbol	Condition	Min.	Typ.	Max.	Unit	Measuring Circuit
Resistor for Oscillation	R _{S0} , R _{S1} , R _{T0} , R _{T0-1} , R _{T1}	C _{S0} , C _{T0} , C _{S1} ≥ 740pF	1	-	-	kΩ	5
Input Current Limiting Resistor	R _{I0} , R _{I1}	-	1	10	-	kΩ	
Oscillation Frequency	f _{OSC1}	Resistor for oscillation =2 kΩ	200	239	277	kHz	
	f _{OSC2}	Resistor for oscillation =10 kΩ	46.5	55.4	64.3	kHz	
	f _{OSC3}	Resistor for oscillation =200 kΩ	2.79	3.32	3.85	kHz	
RS•RT Oscillation Frequency Ratio(*)	Kf1	R _{T0} , R _{T0-1} , R _{T1} = 2 kΩ	4.272	4.380	4.490	-	
	Kf2	R _{T0} , R _{T0-1} , R _{T1} = 10 kΩ	0.990	1.000	1.010	-	
	Kf3	R _{T0} , R _{T0-1} , R _{T1} = 200 kΩ	0.0573	0.0616	0.0659	-	

* K_{fx} is the ratio of the oscillation frequency by a sensor resistor to the oscillation frequency by a reference resistor in the same condition.

$$K_{fx} = \frac{f_{OSCx}(RT0 - CS0 \text{ Oscillation})}{f_{OSCx}(RS0 - CS0 \text{ Oscillation})}, \quad \frac{f_{OSCx}(RT0-1 - CS0 \text{ Oscillation})}{f_{OSCx}(RS0 - CS0 \text{ Oscillation})}, \quad \frac{f_{OSCx}(RT1 - CS1 \text{ Oscillation})}{f_{OSCx}(RS1 - CS1 \text{ Oscillation})}$$

(x = 1, 2, 3)

Measuring circuit 5

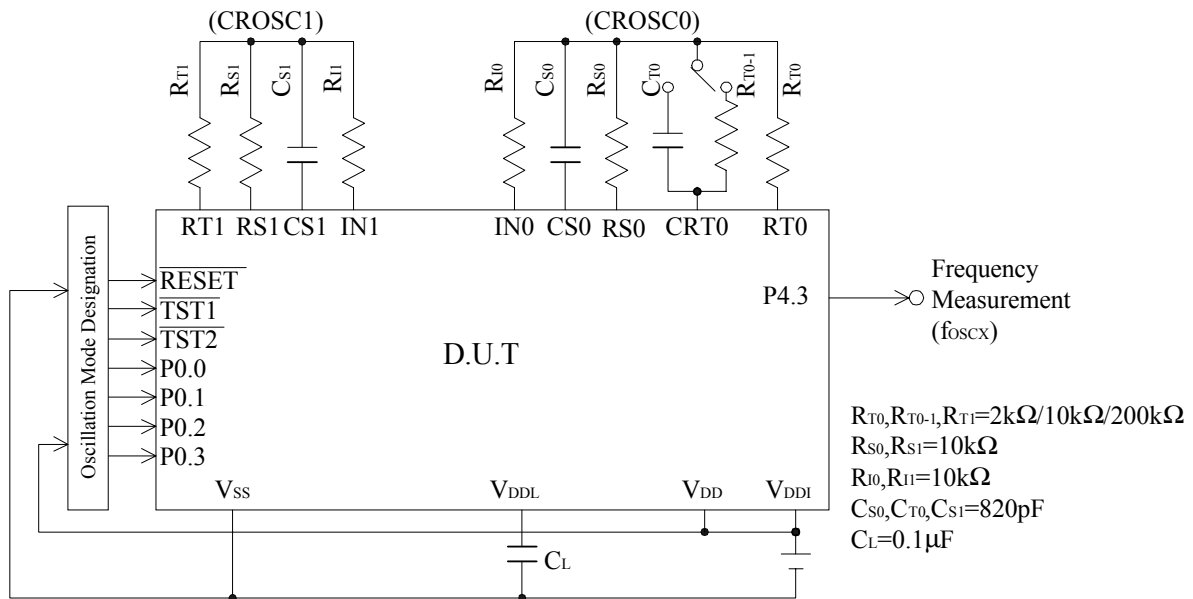

AC Characteristics (3.0V Spec.) (Serial Interface)

(VSS=0V, VDD=3.0V, VDDI=5.0V , Ta=-40 to +85°C unless otherwise specified)

Parameter	Symbol	Condition	Min.	Typ.	Max.	Unit
SCLK Input Fall Time	t_f	-	-	15	50	ns
SCLK Input Rise Time	t_r	-	-	15	50	ns
SCLK Input "L" Level Pulse Width	t_{cWL}	-	0.8	-	-	μ s
SCLK Input "H" Level Pulse Width	t_{cWH}	-	0.8	-	-	μ s
SCLK Input Cycle Time	t_{cYC}	-	2.0	-	-	μ s
SCLK Output Cycle Time	$t_{cYC1(O)}$	CPU is operating at 32.768kHz	-	30.5	-	μ s
SCLK Output Cycle Time	$t_{cYC2(O)}$	CPU is operating at 700kHz	-	1.43	-	μ s
SOUT Output Delay Time	t_{DDR}	$C_L=10pF$	-	-	0.4	μ s
SIN Input Setup Time	t_{DS}	-	0.5	-	-	μ s
SIN Input Hold Time	t_{DH}	-	0.8	-	-	μ s

Synchronous communication timing

("H" level = 4.0V, "L" level = 1.0V)

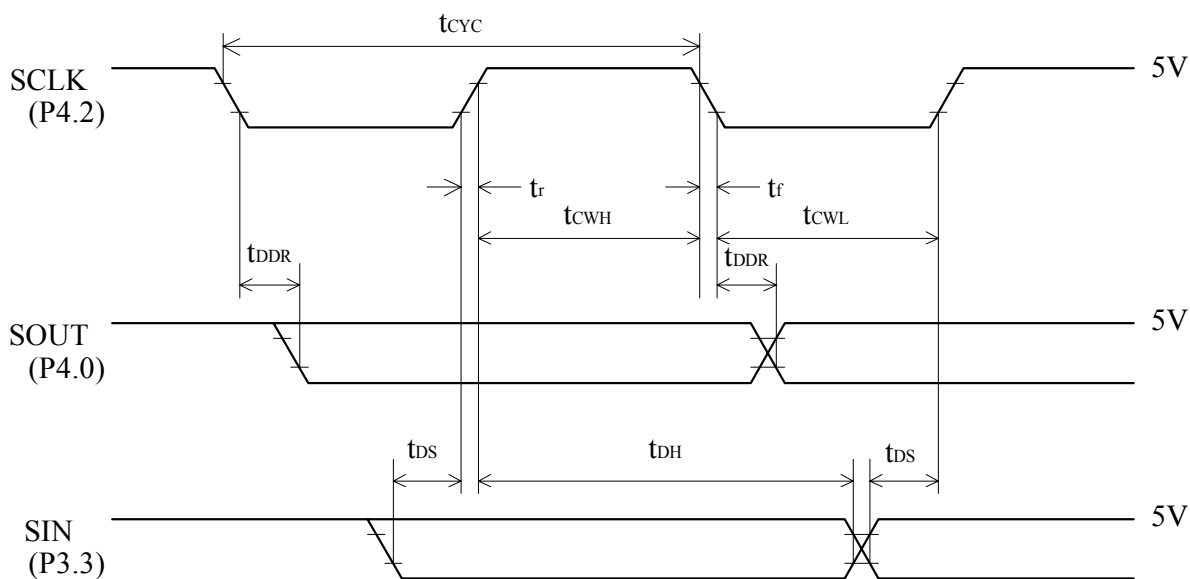

RECOMMENDED OPERATING CONDITIONS (When Voltage Regulator for LCD Driver Used)

(V_{SS} = 0V)

Parameter	Symbol	Condition	Rating	Unit
Operating Temperature	T _{op}	-	-40 to +85	°C
Operating Voltage	V _{DD}	-	1.25 to 3.5	V
Crystal oscillation frequency	f _{XT}	-	30 to 66	kHz

ELECTRICAL CHARACTERISTICS (When Voltage Regulator for LCD Driver Used)

DC Characteristics

(V_{SS}=0V, V_{DD}=3.0V, T_a=-40 to +85°C unless otherwise specified)

Parameter	Symbol	Condition	Min.	Typ.	Max.	Unit	Measuring Circuit
V _{DD1} Voltage	V _{DD1}	V _{DD} =1.25 to 3.5, T _a =25°C	1.00	1.2	1.40	V	1
	ΔV _{DD1}	-	-	-4	-	mV/°C	
V _{DD2} Voltage	V _{DD2}	V _{DD} =1.25 to 3.5	Typ. - 0.1	2×V _{DD1}	Typ. + 0.1	V	
V _{DD3} Voltage	V _{DD3}	V _{DD} =1.25 to 3.5	Typ. - 0.2	3×V _{DD1}	Typ. + 0.2		
Supply Current 1	I _{DD1}	V _{DD} =1.5V, CPU in halt state	-	2	5	μA	
		V _{DD} =3.0V, CPU in halt state	-	2	5		
Supply Current 2	I _{DD2}	V _{DD} =1.5V, CPU in operating state	-	5	15		
		V _{DD} =3.0V, CPU in operating state	-	5	15		

Notes: The other electrical characteristics are the same as those for the 1.5V and 3.0V specifications.

Power Supply Circuit

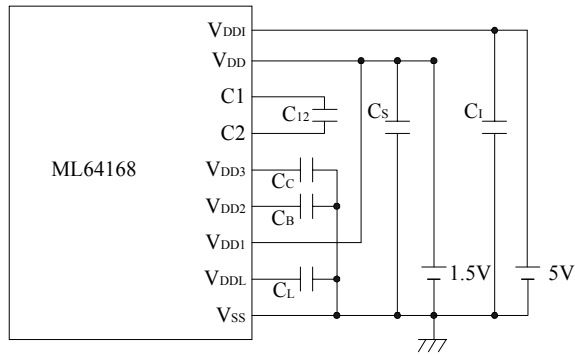

ML64168 1.5V Version

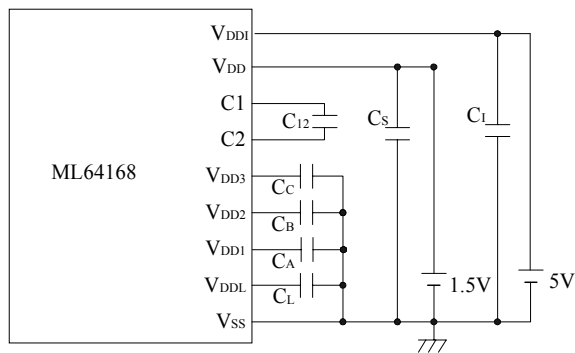

ML64168 1.5V Version.(The LCD bias is regulated.)

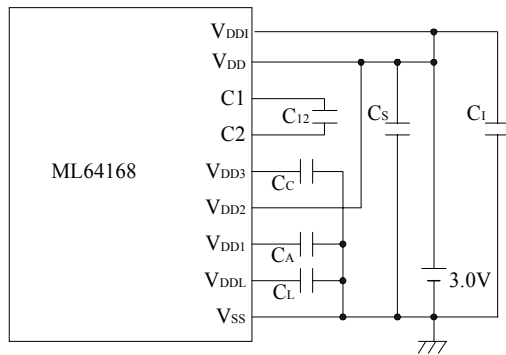

ML64168 3.0V Version

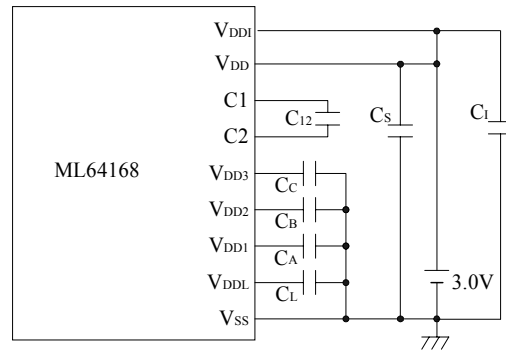

ML64168 3.0V Version.(The LCD bias is regulated.)

Note: CA, CB, CC, CS, C1, C1, C12: 0.1μF ^{+100%}
 C1: 0.47μF _{-50%}

FUNCTIONAL DESCRIPTION

CPU Peripheral Function

• A/D converter (ADC)

The ML64168 has a built-in two-channel RC oscillation A/D converter. The A/D converter is composed of a two-channel oscillation circuit, Counter A (CNTA0-4, a 4.8-digit decade counter), Counter B (CNTB0-3, a 14-bit binary counter), and A/D Converter Control Registers 0 and 1 (ADCON0, ADCON1).

By counting oscillation frequencies that vary depending on a resistor or capacitor connected to the RC oscillation circuit, the A/D converter converts resistance values or capacitance values to corresponding digital values. By using a thermistor or humidity sensor as a resistance, a thermometer or a hygrometer can be constructed. By applying a separate sensor to each channel of the 2-channel RC oscillation circuit, it is also possible to extend measure ranges or measure at two places.

• Serial port (SIOP)

The ML64168 has an 8-bit synchronous serial port. Receive/transmit operation of the serial port is performed simultaneously and the serial transfer clock can select either internal or external mode. Direction of transfer data can be big endian or little endian. Each pin of the serial port is assigned as secondary functions of P3.3 and P4.0 to P4.2. Setting each bit of SIN, SOUT, SPR and SCLK of P33CON and P40CON to P42CON to "1" makes each pin valid.

• LCD driver (LCD)

The ML64168 has a built-in LCD driver for 34 outputs.

The LCD driver consists of 31× 4-bit display registers (DSPR0-30), the Display Control Register (DSPCON), a 34-output LCD driver circuit, and a bias generation circuit (BIAS).

The bias generation circuit for LCD driver (BIAS) generates bias voltages for the LCD driver by rising or dropping the power supply voltage by externally installing capacitors. Alternatively, it generates bias voltages by rising the constant voltage ($V_{DD1} = 1.2V$) generated by the voltage regulator for LCD driver. Which way is to be used is specified by mask option.

There are three types of driving methods: 1/4duty, 1/3duty and 1/2duty. Software selects the duty mode.

A mask option can select either a common driver or a segment driver for each LCD driver pin. A mask option can also specify assignment of each bit of the display register to each segment. All the display registers must be selected by a mask option.

L26 to L33 of the LCD driver can be configured to be output ports by a mask option.

The relationship between the duty, the bias method, and the maximum segment number follows:

1/4duty, 1/3 bias method	-----	120 segments
1/3duty, 1/3 bias method	-----	93 segments
1/2duty, 1/2 bias method	-----	64 segments

• Buzzer driver (BD)

The ML64168 has a built-in buzzer driver with 15 buzzer output frequencies and 4 buzzer output modes. Each buzzer output is selected by the Buzzer Control Register (BDCON) and the Buzzer Frequency Control Register (BFCON).

• Capture circuit (CAPR)

The ML64168 captures 32Hz to 256Hz output of the time base counter at the falling of Port 0.0 or Port 0.1 (P0.0 or P0.1) to “L” level when the pull-up resistor input is chosen, or at the rising to “H” level when the pull-down resistor input is chosen. The capture circuit is composed of the Capture Control Register (CAPCON) and the Capture Registers (CAPR0, CAPR1) that fetch output from the time base counter.

• Watchdog timer (WDT)

The ML64168 has a built-in watchdog timer to detect CPU malfunction. The watchdog timer is composed of a 6-bit watchdog timer counter (WDTC) to count a 16Hz output and a watchdog timer control register (WDTCON) to reset WDTC.

• Clock generation circuit (2CLK)

The clock generation circuit (2CLK) in the ML64168 contains a 32.768kHz crystal oscillation circuit, a 700kHz RC oscillation circuit, and a clock control port. This circuit generates the system clock (CLK) and the time base clock (32.768kHz).

The system clock drives the CPU while the time base clock drives the time base counter and the buzzer driver.

Via the contents of the Frequency Control Register (FCON), the system clock can be switched between 32.768kHz (the output of the crystal oscillation circuit) and 700kHz (the output of the RC oscillation circuit).

Note: The oscillation frequency of the RC oscillation circuit varies depending on the value of an external resistor (R_{os}), operating power supply voltage (V_{DD}), and ambient temperatures (T_a).

• Time base counter (TBC)

The ML64168 has a built-in time base counter (TBC) that generates clocks to be supplied to internal peripheral circuit. The time base counter is composed of 15 binary counters, and a 1/10 frequency dividing circuit. The count clock of the time base is driven by the oscillation clock (32.768kHz) of the crystal oscillation circuit. The output of the time base counter is used for the buzzer driver, the system reset circuit, the watchdog timer, the time base interrupt, the sampling clocks of each port, and the capture circuit.

• I/O port

Input-output ports (P2, P3, P4) : 3 ports × 4bits

Pull-up (pull-down) resistor input or high-impedance input, CMOS output or NMOS open drain output: these can be specified for each bit; external 0 interrupt

Input port (P0) : 1 port × 4bits

Pull-up (pull-down) resistor input or high-impedance input; external 1 interrupt

Output port (P1) : 1 port × 4bits

CMOS output or NMOS open drain output

• Interrupt (INTC)

The ML64168 has 10 interrupt sources (10 vector address), of which two are external interrupts from ports and eight are internal interrupts.

Of the ten interrupt sources, only the watchdog timer interrupt cannot be disabled (non-maskable interrupt). The other nine interrupts are controlled by the master interrupt enable flag (MI) and the interrupt enable registers (IE0, IE1, and IE2). When an interrupt condition is met, the CPU branches to a vector address corresponding to the interrupt source.

• Battery check circuit (BC)

The battery check circuit (BC) detects the level of the supply voltage by comparing the voltage generated by an external supply-voltage dividing resistor (R_{BLD}) with the internal reference voltage (V_{rb}).

APPLICATION CIRCUITS (1.5 V Spec.)

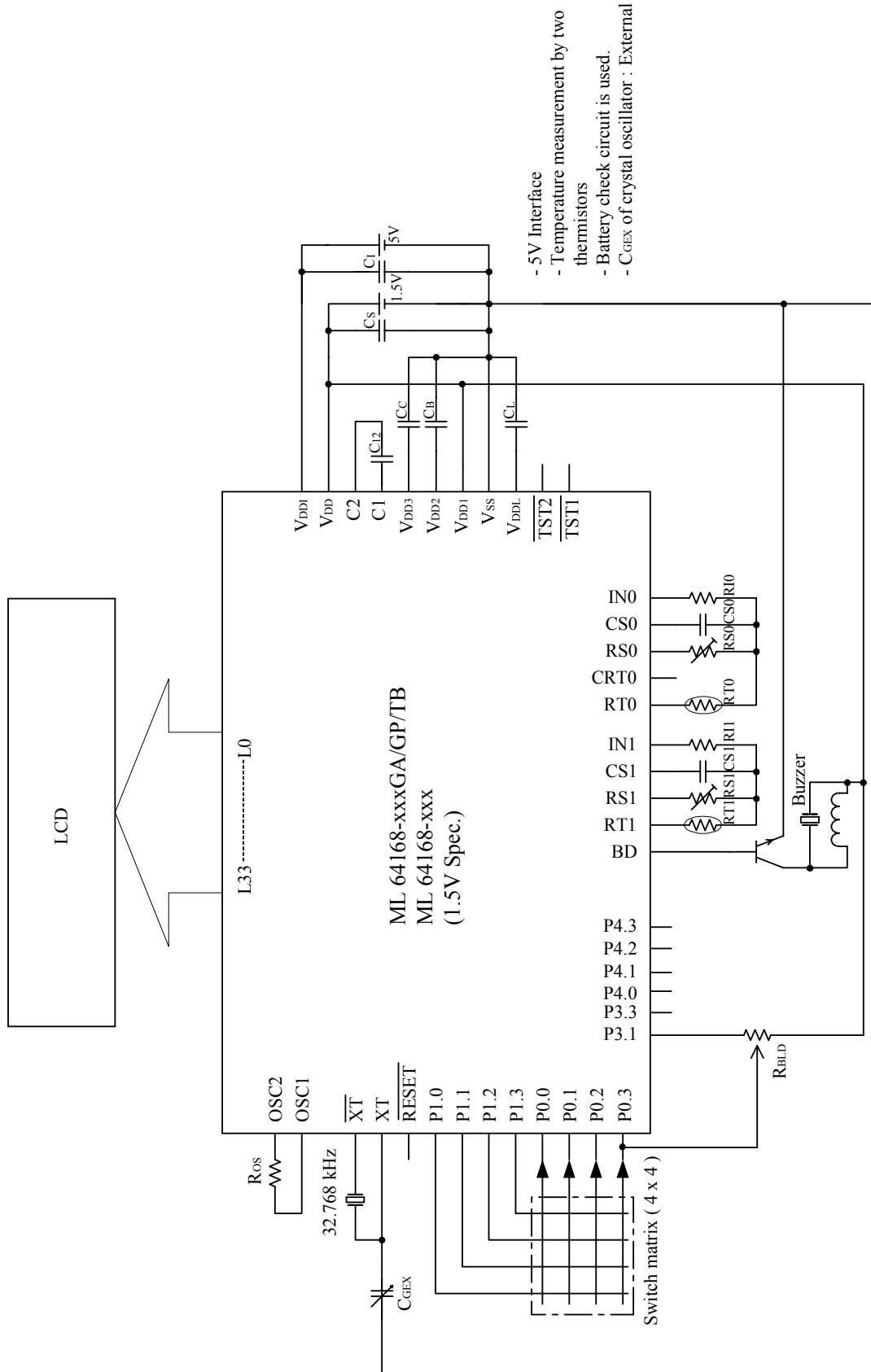

1.5V Spec. Application Circuit (Voltage Regulator for LCD Driver not Used)

APPLICATION CIRCUITS (1.5 V Spec.) (continued)

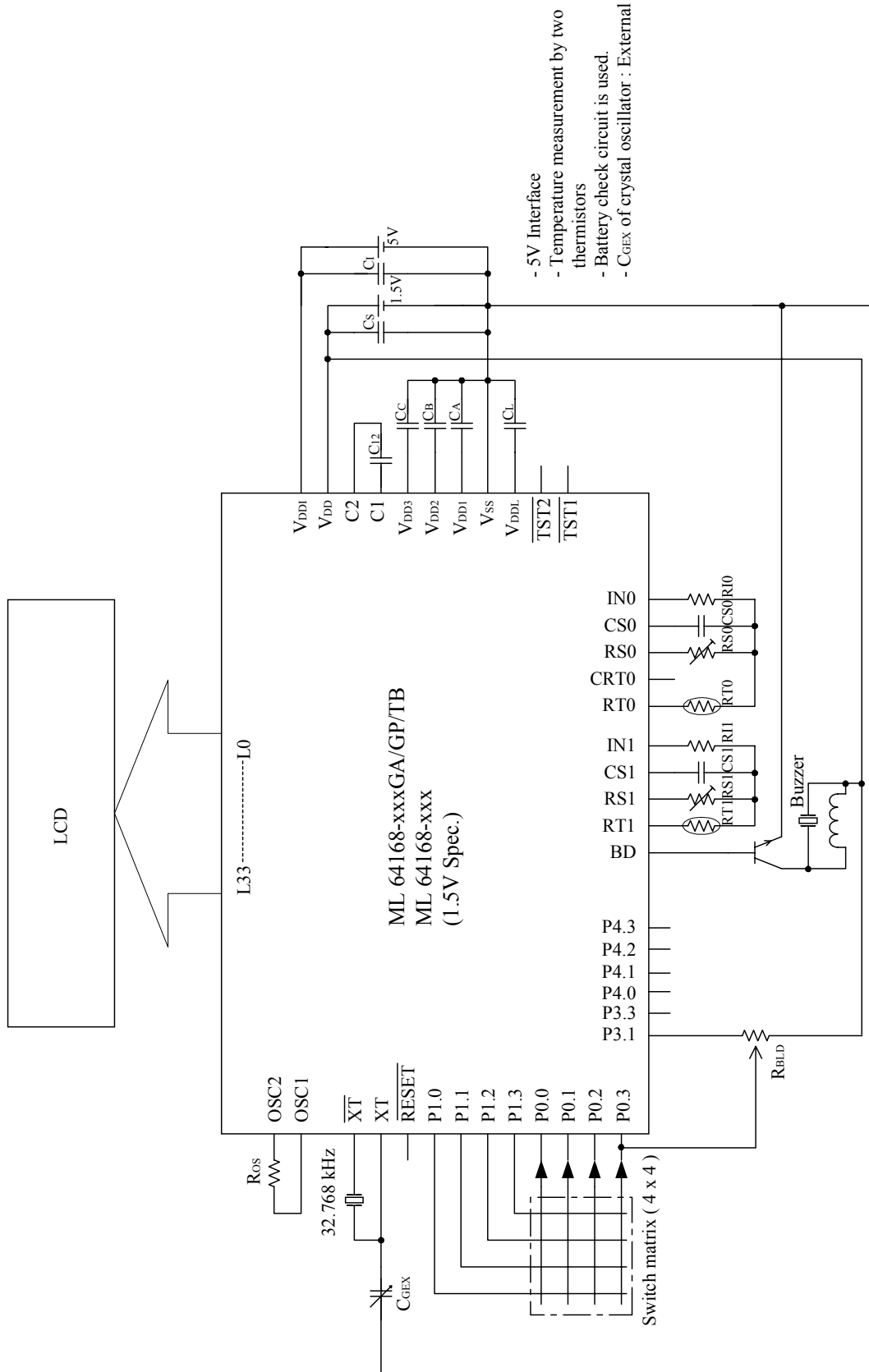

1.5V Spec. Application Circuit (Voltage Regulator for LCD Driver Used)

APPLICATION CIRCUITS (3.0 V Spec.)

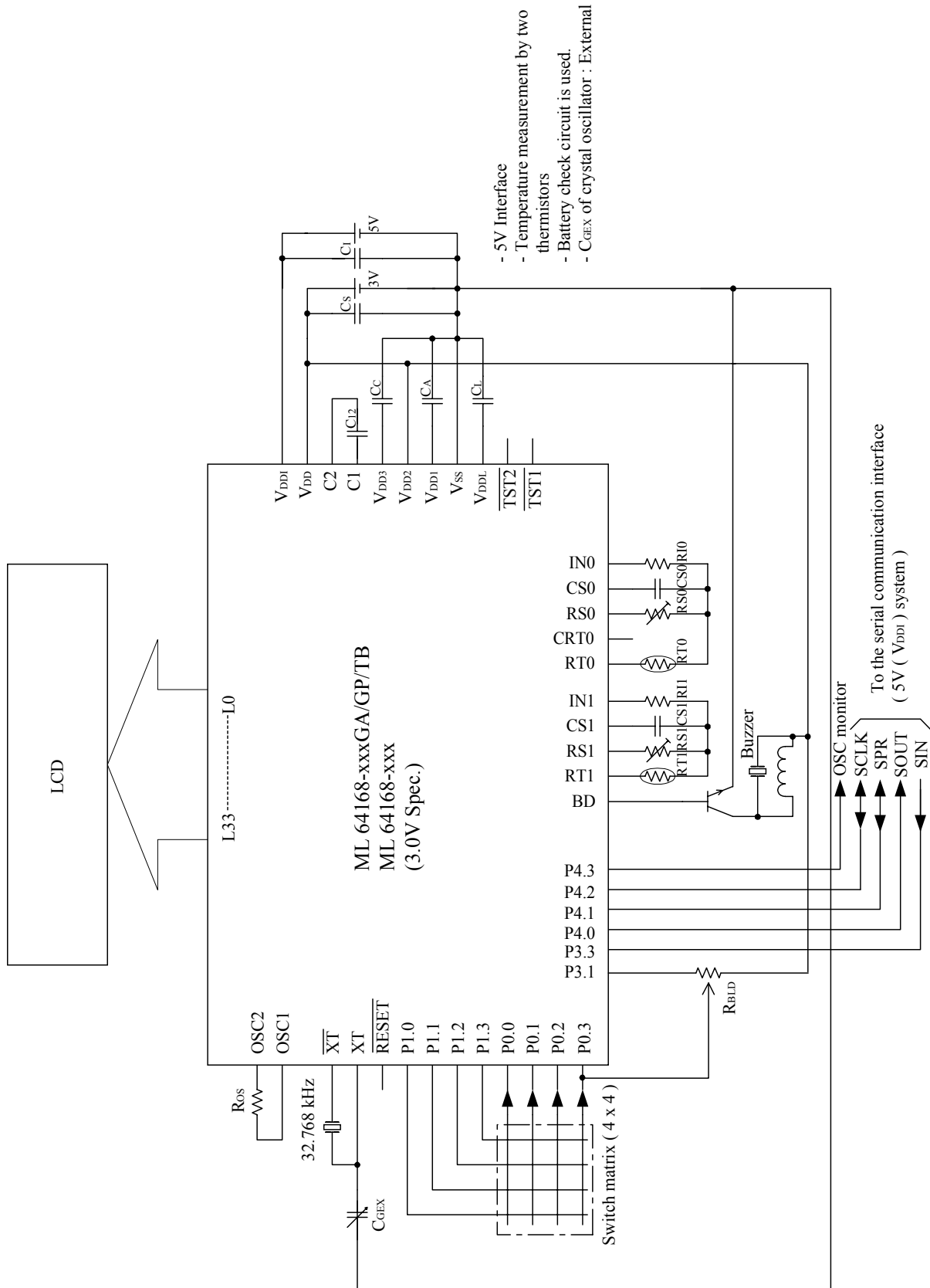

3.0V Spec. Application Circuit (Voltage Regulator for LCD Driver not Used)

APPLICATION CIRCUITS (3.0 V Spec.) (continued)

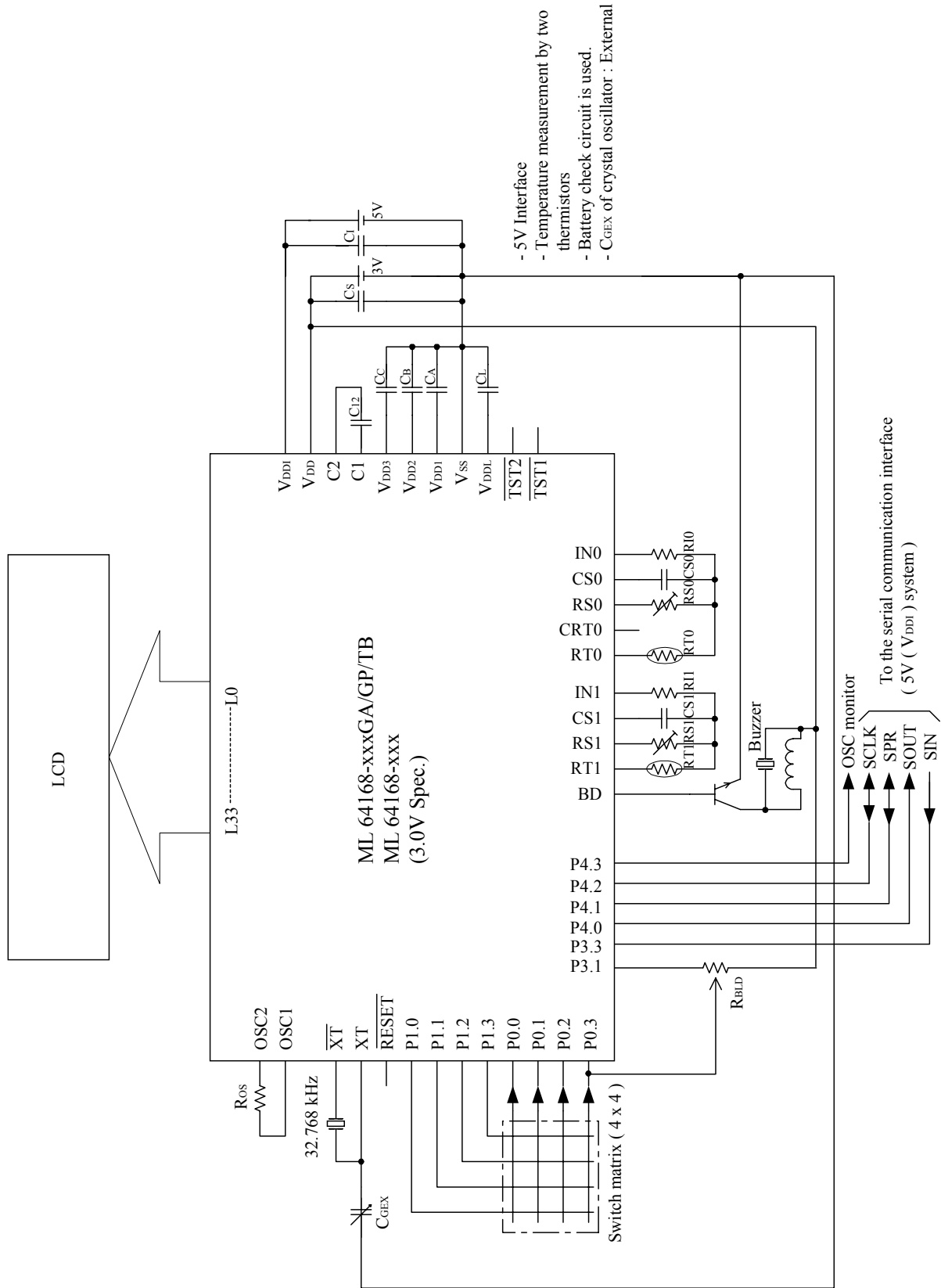

3.0V Spec. Application Circuit (Voltage Regulator for LCD Driver Used)

PACKAGE DIMENSIONS
ML64168-xxxGP

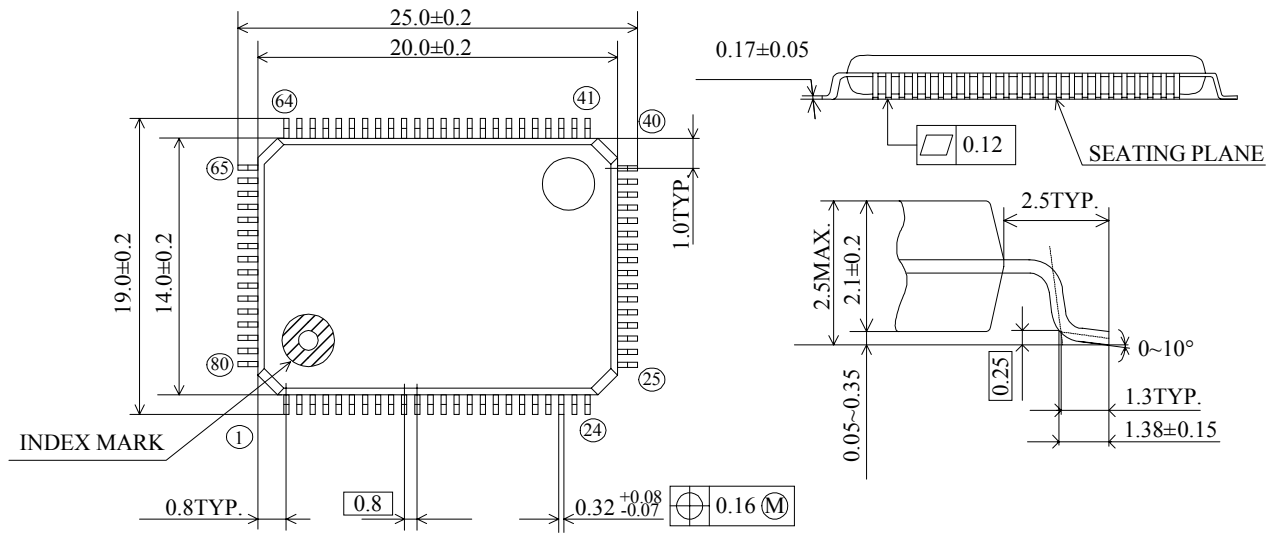

Figure C-1 80-Pin QFP:GP Package Dimension Diagram

Notes for Mounting the Surface Mount Type Package

The SOP, QFP, TSOP, SOJ, QFJ (PLCC), SHP and BGA are surface mount type packages, which are very susceptible to heat in reflow mounting and humidity absorbed in storage. Therefore, before you perform reflow mounting, contact Oki's responsible sales person for the product name, package name, pin number, package code and desired mounting conditions (reflow method, temperature and times).

PACKAGE DIMENSIONS
ML64168-xxxGA

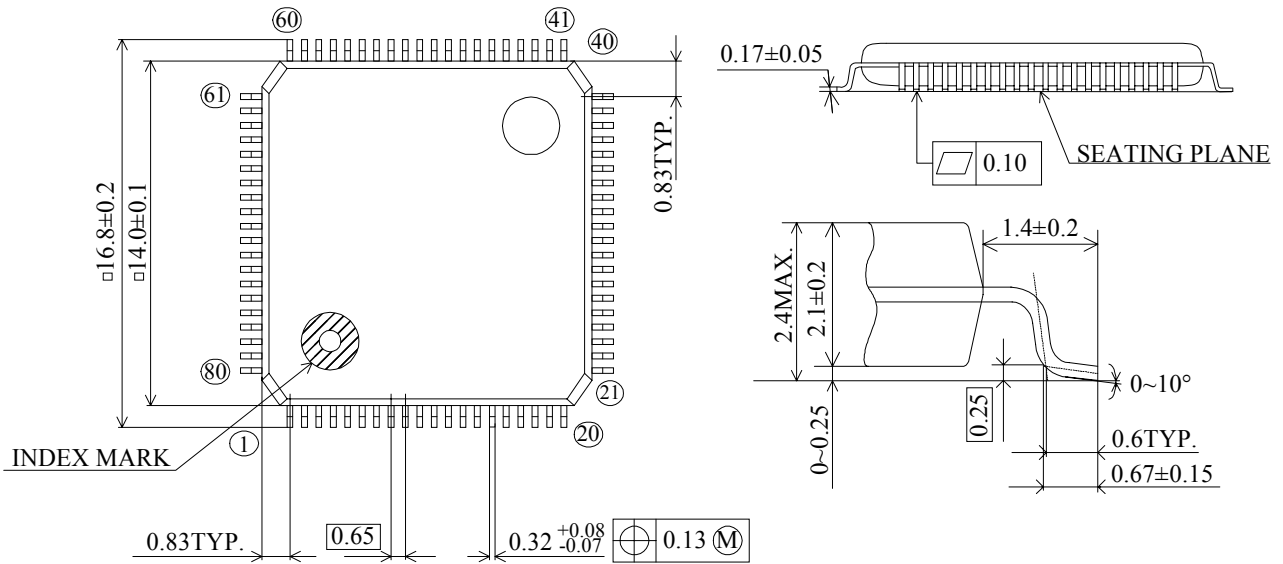

Figure C-2 80-Pin QFP:GA Package Dimension Diagram

Notes for Mounting the Surface Mount Type Package

The SOP, QFP, TSOP, SOJ, QFJ (PLCC), SHP and BGA are surface mount type packages, which are very susceptible to heat in reflow mounting and humidity absorbed in storage.

Therefore, before you perform reflow mounting, contact Oki's responsible sales person for the product name, package name, pin number, package code and desired mounting conditions (reflow method, temperature and times).

PACKAGE DIMENSIONS
ML64168-xxxTB

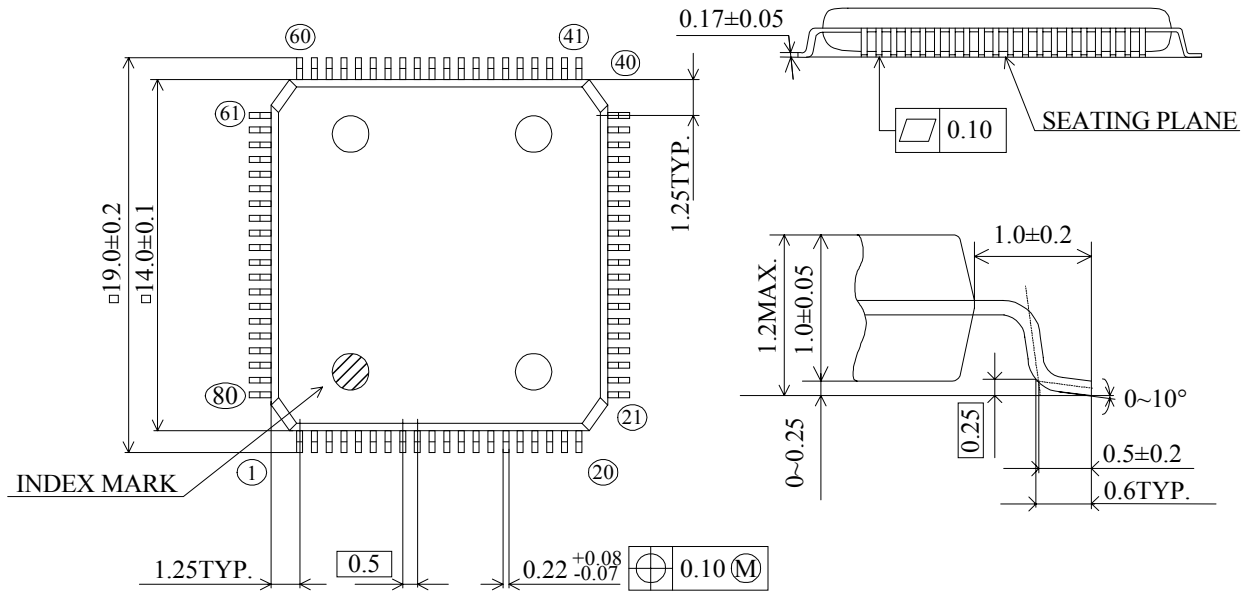

Figure C-3 80-Pin QFP:TB Package Dimension Diagram

Notes for Mounting the Surface Mount Type Package

The SOP, QFP, TSOP, SOJ, QFJ (PLCC), SHP and BGA are surface mount type packages, which are very susceptible to heat in reflow mounting and humidity absorbed in storage.

Therefore, before you perform reflow mounting, contact Oki's responsible sales person for the product name, package name, pin number, package code and desired mounting conditions (reflow method, temperature and times).