

ML9206-xx**5 × 7 Dot Character × 16-Digit Display Controller/Driver with Character RAM****GENERAL DESCRIPTION**

The ML9206-xx is a dot matrix vacuum fluorescent display tube controller driver IC which displays characters, numerics and symbols.

Dot matrix vacuum fluorescent display tube drive signals are generated by serial data sent from a micro-controller. A display system is easily realized by internal ROM and RAM for character display.

The ML9206-xx has low power consumption since it is made by CMOS process technology.

-01 is available as a general-purpose code.

Custom codes are provided on customer's request.

FEATURES

- Logic power supply and vacuum fluorescent display tube drive power supply (V_{DD}) : 3.3 V \pm 10% or 5.0 V \pm 10%
 - Fluorescent display tube drive power supply (V_{FL}) : -20 to -60 V
 - VFD driver output current
(VFD driver output can be connected directly to the fluorescent display tube. No pull-down resistor is required.)
 - Segment driver (SEG1 to SEG35) : -6 mA ($V_{FL}=-60V$)
 - Segment driver (AD1 and AD2) : -15 mA ($V_{FL}=-60V$)
 - Grid driver (COM1 to COM16) : -30 mA ($V_{FL}=-60V$)
 - General output port output current
 - Output driver (P1 and P2) : ± 1 mA ($V_{DD}=3.3V\pm 10\%$)
: ± 2 mA ($V_{DD}=5.0V\pm 10\%$)
 - Content of display
 - CGROM 5 \times 7 dots : 248 types (character data)
 - CGRAM 5 \times 7 dots : 8 types (character data)
 - ADRAM 16 (display digit) \times 2 bits (symbol data)
 - DCRAM 16 (display digit) \times 8 bits (register for character data display)
 - General output port 2 bits (static operation)
 - Display control function
 - Display digit : 1 to 16 digits
 - Display duty (brightness adjustment) : 256 stages
 - All lights ON/OFF
 - 3 interfaces with microcontroller : DA, \overline{CS} , \overline{CP} (4 interfaces when \overline{RESET} is added)
 - 1-byte instruction execution (excluding data write and display duty set mode to RAM)
 - Built-in oscillation circuit (external R and C)
 - Package options:
 - 64-pin plastic QFP (QFP64-P-1414-0.80-BK) (Product name : ML9206-xxGS-BK)
 - 64-pin plastic SSOP (SSOP64-P-525-0.80-K) (Product name : ML9206-xxGS-K)
- xx indicates the code number.

BLOCK DIAGRAM

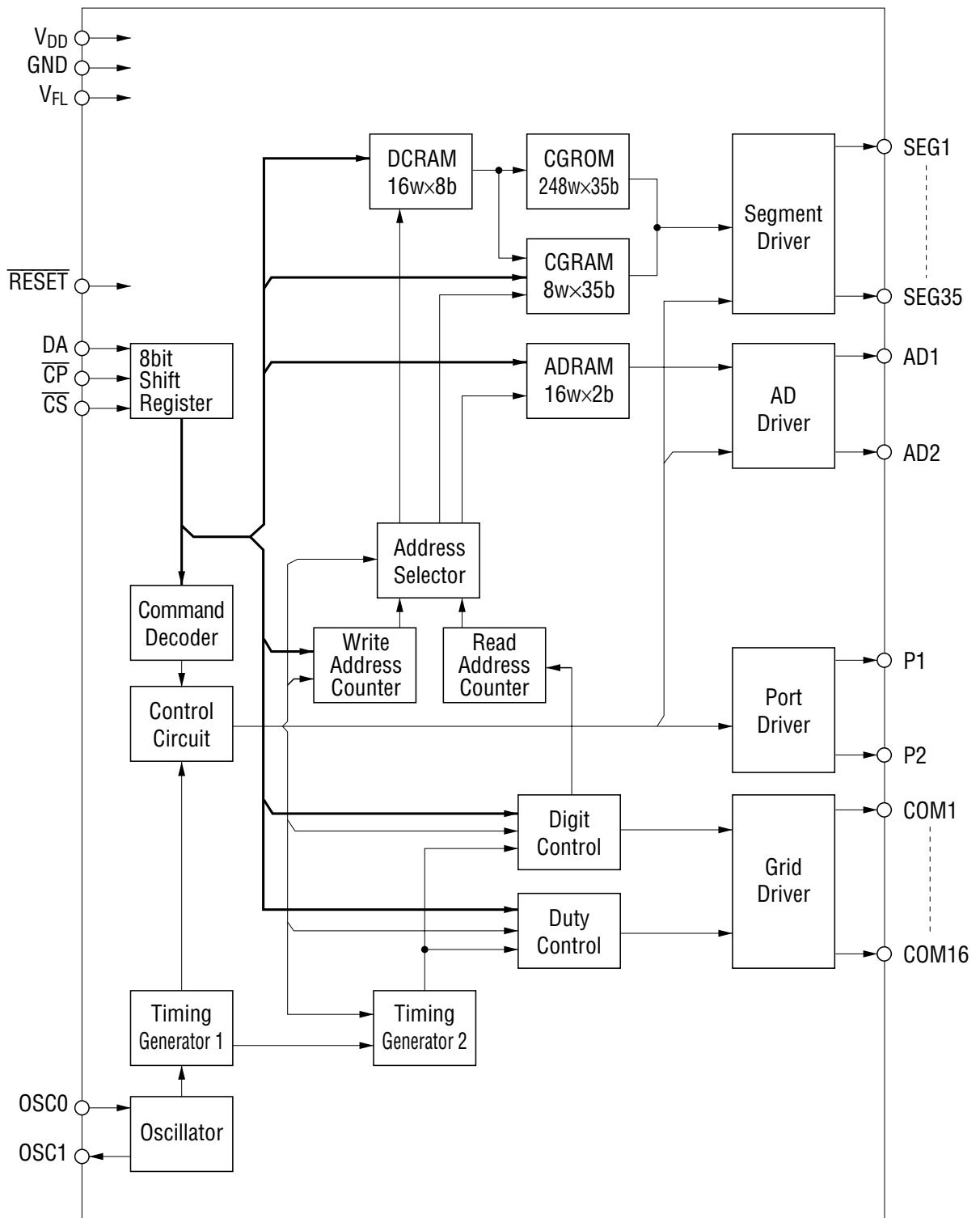

INPUT AND OUTPUT CONFIGURATION

Schematic Diagrams of Logic Portion Input and Output Circuits

Input Pin

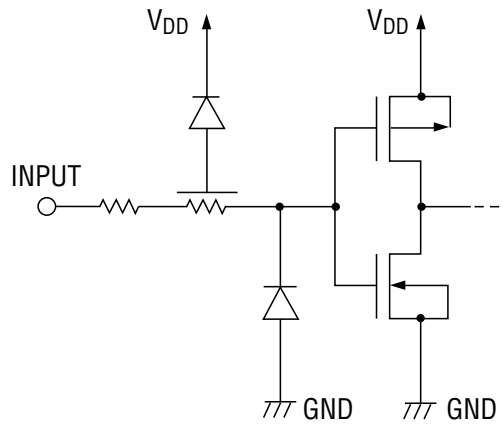

Output Pin

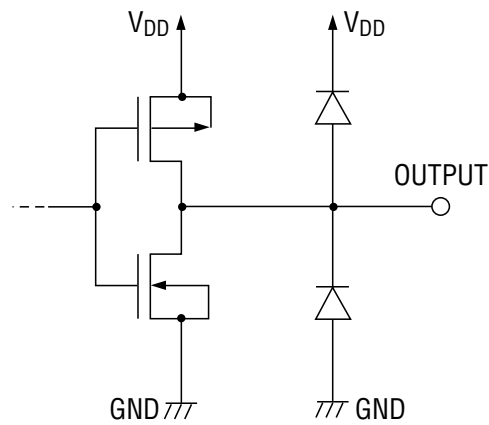

Schematic Diagram of Driver Output Circuit

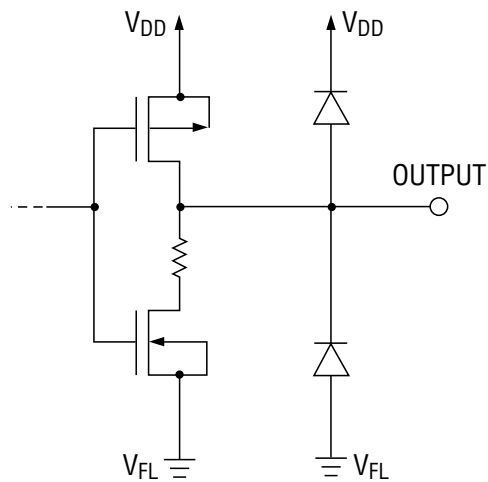

PIN CONFIGURATION (TOP VIEW)

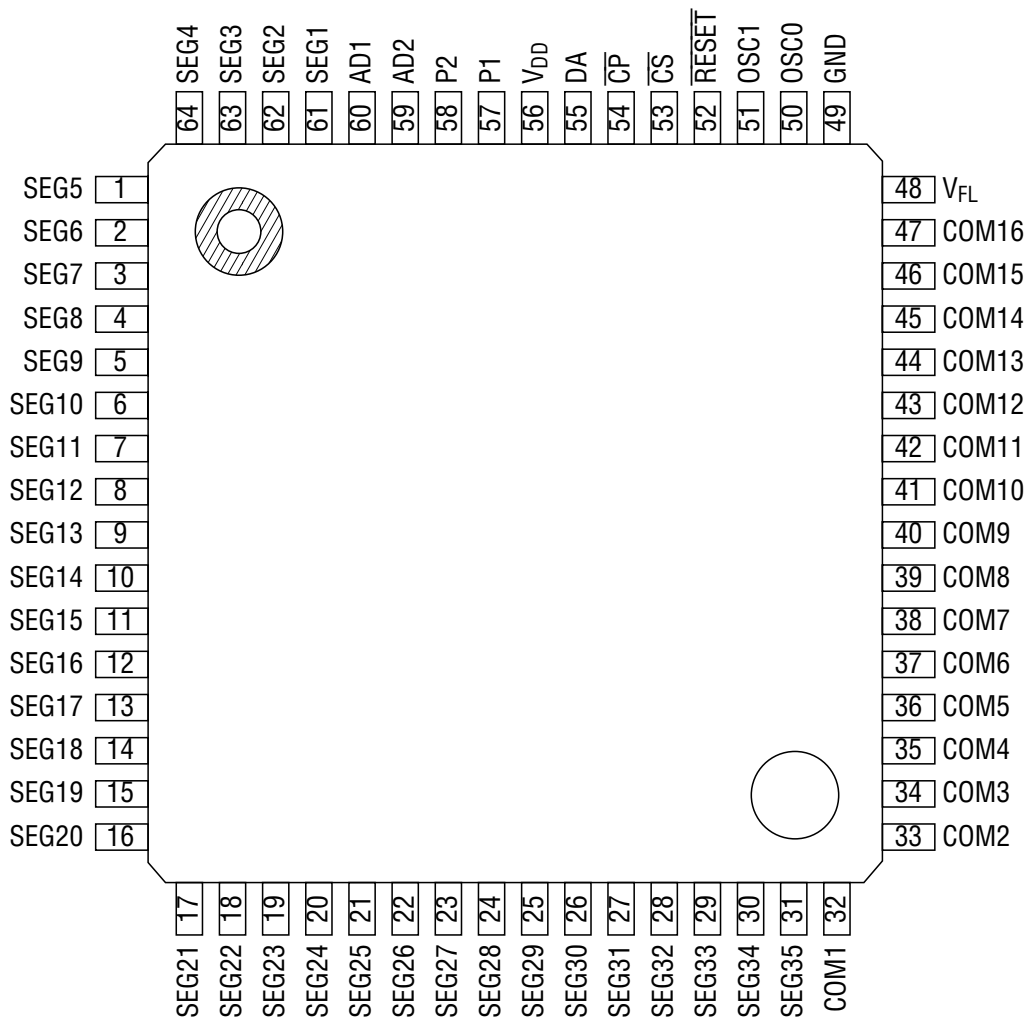

NC: No connection

64-Pin Plastic QFP

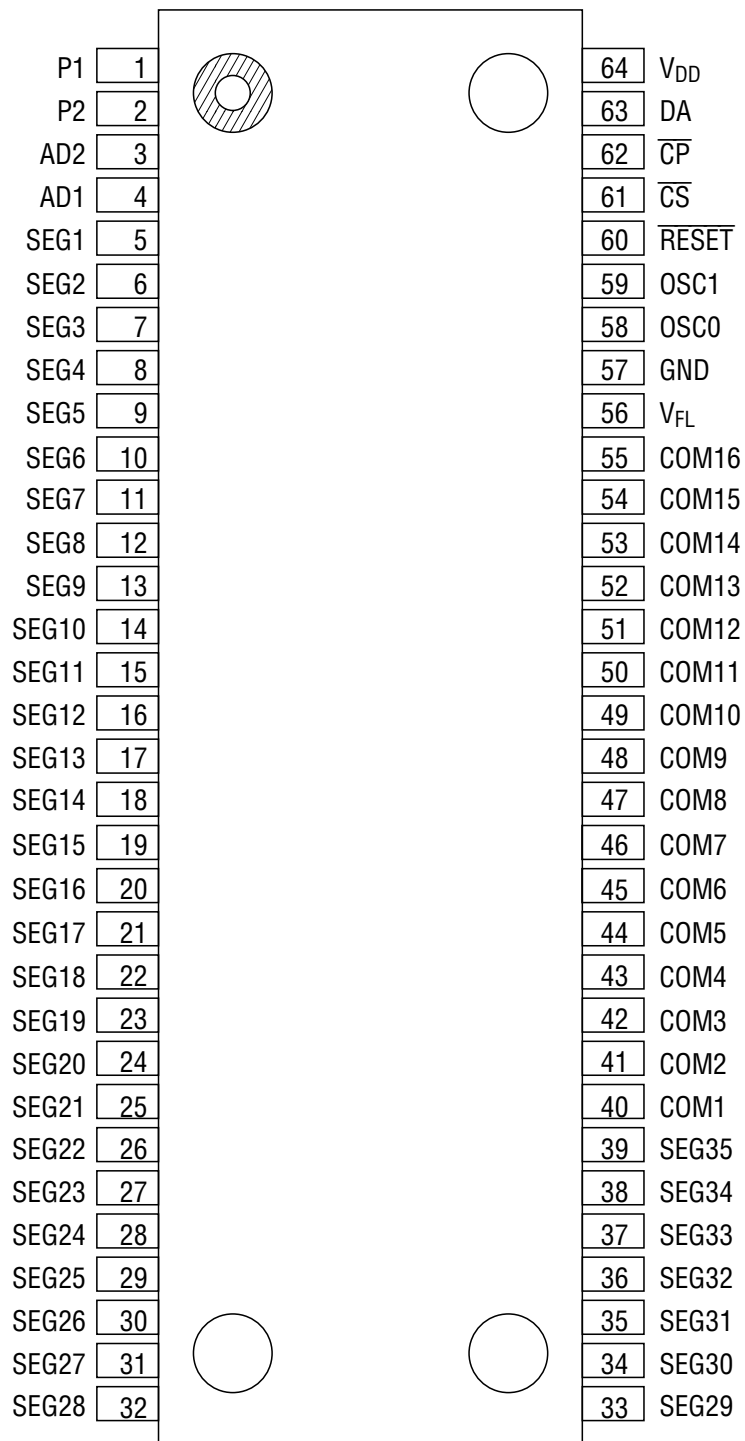

64-Pin Plastic SSOP

PIN DESCRIPTION

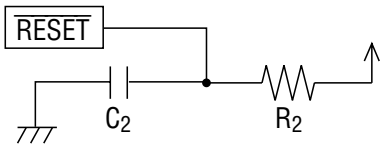
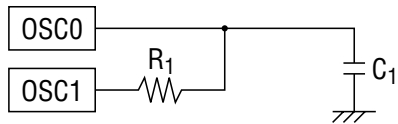
Pin		Symbol	Type	Connects to	Description
QFP	SSOP				
1 to 31, 61 to 64	5 to 39	SEG1 to 35	0	Fluorescent tube anode electrode	Fluorescent display tube anode electrode drive output. Directly connected to fluorescent display tube and a pull-down resistor is not necessary. $I_{OH} > -6$ mA
32 to 47	40 to 55	COM1 to 16	0	Fluorescent tube grid electrode	Fluorescent display tube grid electrode drive output. Directly connected to fluorescent display tube and a pull-down resistor is not necessary. $I_{OH} > -30$ mA
59, 60	3, 4	AD1, AD2	0	Fluorescent tube anode electrode	Fluorescent display tube anode electrode drive output. Directly connected to fluorescent display tube and a pull-down resistor is not necessary. $I_{OH} > -15$ mA
57, 58	1, 2	P1, P2	0	LED drive control pins	General port output. Output of these pins in static operation, so these pins can drive the LED.
56	64	V _{DD}	—	Power supply	V _{DD} -GND are power supplies for internal logic. V _{DD} -V _{FL} are power supplies for driving fluorescent tubes. Apply V _{FL} after V _{DD} is applied.
49	57	GND			
48	56	V _{FL}			
55	63	DA	I	Micro-controller	Serial data input (positive logic). Input from LSB.
54	62	\overline{CP}	I	Micro-controller	Shift clock input. Serial data is shifted on the rising edge of \overline{CP} .
53	61	\overline{CS}	I	Micro-controller	Chip select input. Serial data transfer is disabled when \overline{CS} pin is "H" level.
52	60	\overline{RESET}	I	Micro-controller or C ₂ , R ₂	<p>Reset input. "Low" initializes all the functions. Initial status is as follows.</p> <ul style="list-style-type: none"> • Address of each RAM address "00"H • Data of each RAM Content is undefined • Display digit 16 digits • brightness adjustment 0/256 • All lights ON or OFF OFF mode • All outputs "Low" level  <p>(Circuit when R and C are connected externally) See Application Circuit.</p>
50	58	OSC0	I	C ₁ , R ₁	<p>External RC pin for RC oscillation. Connect R and C externally. The RC time constant depends on the V_{DD} voltage used. Set the target oscillation frequency to 2 MHz.</p>  <p>(RC oscillation circuit) See Application Circuit.</p>
51	59	OSC1	0		

ABSOLUTE MAXIMUM RATINGS

Parameter	Symbol	Condition	Rating	Unit	
Supply Voltage (1)	V_{DD}	—	-0.3 to +6.5	V	
Supply Voltage (2)	V_{FL}	—	-80 to $V_{DD}+0.3$	V	
Input Voltage	V_{IN}	—	-0.3 to $V_{DD}+0.3$	V	
Power Dissipation	P_D	$T_a \geq 25^\circ\text{C}$	QFP	541	mW
			SSOP	590	
Storage Temperature	T_{STG}	—	-55 to +150	$^\circ\text{C}$	
Output Current	I_{O1}	COM1 to COM16	-40 to 0.0	mA	
	I_{O2}	AD1, AD2	-20 to 0.0		
	I_{O3}	SEG1 to SEG35	-10 to 0.0		
	I_{O4}	P1, P2	-4.0 to +4.0		

RECOMMENDED OPERATING CONDITIONS-1

When the power supply voltage is 5V (typ.)

Parameter	Symbol	Condition	Min.	Typ.	Max.	Unit
Supply Voltage (1)	V_{DD}	—	4.5	5.0	5.5	V
Supply Voltage (2)	V_{FL}	—	-60	—	-20	V
High Level Input Voltage	V_{IH}	All input pins excluding OSC0 pin	$0.7V_{DD}$	—	—	V
Low Level Input Voltage	V_{IL}	All input pins excluding OSC0 pin	—	—	$0.3V_{DD}$	V
\overline{CP} Frequency	f_C	—	—	—	2.0	MHz
Oscillation Frequency	f_{OSC}	$R_1=3.3\text{k}\Omega$, $C_1=47\text{pF}$	1.5	2.0	2.5	MHz
Frame Frequency	f_{FR}	DIGIT=1 to 16, $R_1=3.3\text{k}\Omega$, $C_1=47\text{pF}$	183	244	305	Hz
Operating Temperature	T_{op}	—	-40	—	+85	$^\circ\text{C}$

RECOMMENDED OPERATING CONDITIONS-2

When the power supply voltage is 3.3V (typ.)

Parameter	Symbol	Condition	Min.	Typ.	Max.	Unit
Supply Voltage (1)	V_{DD}	—	3.0	3.3	3.6	V
Supply Voltage (2)	V_{FL}	—	-60	—	-20	V
High Level Input Voltage	V_{IH}	All input pins excluding OSC0 pin	$0.8V_{DD}$	—	—	V
Low Level Input Voltage	V_{IL}	All input pins excluding OSC0 pin	—	—	$0.2V_{DD}$	V
CP Frequency	f_C	—	—	—	2.0	MHz
Oscillation Frequency	f_{OSC}	$R_1=3.3k\Omega$, $C_1=39pF$	1.5	2.0	2.5	MHz
Frame Frequency	f_{FR}	DIGIT=1 to 16, $R_1=3.3k\Omega$, $C_1=39pF$	183	244	305	Hz
Operating Temperature	T_{op}	—	-40	—	+85	°C

ELECTRICAL CHARACTERISTICS

DC Characteristics-1

($V_{DD}=5.0V\pm 10\%$, $V_{FL}=-60V$, $T_a=-40$ to $+85^\circ C$, unless otherwise specified)

Parameter	Symbol	Applied pin	Condition	Min.	Max.	Unit	
High Level Input Voltage	V_{IH}	\overline{CS} , \overline{CP} , DA, \overline{RESET}	—	$0.7V_{DD}$	—	V	
Low Level Input Voltage	V_{IL}	\overline{CS} , \overline{CP} , DA, \overline{RESET}	—	—	$0.3V_{DD}$	V	
High Level Input Current	I_{IH}	\overline{CS} , \overline{CP} , DA, \overline{RESET}	$V_{IH}=V_{DD}$	-1.0	+1.0	μA	
Low Level Input Current	I_{IL}	\overline{CS} , \overline{CP} , DA, \overline{RESET}	$V_{IL}=0.0V$	-1.0	+1.0	μA	
High Level Output Voltage	V_{OH1}	COM1 to 16	$I_{OH1}=-30mA$	$V_{DD}-1.5$	—	V	
	V_{OH2}	AD1, AD2	$I_{OH2}=-15mA$	$V_{DD}-1.5$	—	V	
	V_{OH3}	SEG1 to 35	$I_{OH3}=-6mA$	$V_{DD}-1.5$	—	V	
	V_{OH4}	P1, P2	$I_{OH4}=-2mA$	$V_{DD}-1.0$	—	V	
Low Level Output Voltage	V_{OL1}	COM1 to 16 AD1, AD2 SEG1 to 35	—	—	$V_{FL}+1.0$	V	
	V_{OL2}	P1, P2	$I_{OL1}=2mA$	—	1.0	V	
Supply Current	I_{DD1}	V_{DD}	$f_{osc}=2MHz$, no load	Duty=240/256 Digit=1 to 16 All output lights ON	—	4	mA
	I_{DD2}			Duty=128/256 Digit=1 to 9 All output lights OFF	—	3	mA

DC Characteristics-2

($V_{DD}=3.3V\pm 10\%$, $V_{FL}=-60V$, $T_a=-40$ to $+85^\circ C$, unless otherwise specified)

Parameter	Symbol	Applied pin	Condition	Min.	Max.	Unit	
High Level Input Voltage	V_{IH}	\overline{CS} , \overline{CP} , DA, \overline{RESET}	—	$0.8V_{DD}$	—	V	
Low Level Input Voltage	V_{IL}	\overline{CS} , \overline{CP} , DA, \overline{RESET}	—	—	$0.2V_{DD}$	V	
High Level Input Current	I_{IH}	\overline{CS} , \overline{CP} , DA, \overline{RESET}	$V_{IH}=V_{DD}$	-1.0	+1.0	μA	
Low Level Input Current	I_{IL}	\overline{CS} , \overline{CP} , DA, \overline{RESET}	$V_{IL}=0.0V$	-1.0	+1.0	μA	
High Level Output Voltage	V_{OH1}	COM1 to 16	$I_{OH1}=-30mA$	$V_{DD}-1.5$	—	V	
	V_{OH2}	AD1, AD2	$I_{OH2}=-15mA$	$V_{DD}-1.5$	—	V	
	V_{OH3}	SEG1 to 35	$I_{OH3}=-6mA$	$V_{DD}-1.5$	—	V	
	V_{OH4}	P1, P2	$I_{OH4}=-1mA$	$V_{DD}-1.0$	—	V	
Low Level Output Voltage	V_{OL1}	COM1 to 16 AD1, AD2 SEG1 to 35	—	—	$V_{FL}+1.0$	V	
	V_{OL2}	P1, P2	$I_{OL1}=1mA$	—	1.0	V	
Supply Current	I_{DD1}	V_{DD}	$f_{osc}=2MHz$, no load	Duty=240/256 Digit=1 to 16 All output lights ON	—	3	mA
	I_{DD2}			Duty=128/256 Digit=1 to 9 All output lights OFF	—	2	mA

AC Characteristics-1

(V_{DD}=5.0V±10%, V_{FL}=-60V, T_a=-40 to +85°C, unless otherwise specified)

Parameter	Symbol	Condition	Min.	Max.	Unit	
$\overline{\text{CP}}$ Frequency	f _C	—	—	2.0	MHz	
$\overline{\text{CP}}$ Pulse Width	t _{CW}	—	250	—	ns	
DA Setup Time	t _{DS}	—	250	—	ns	
DA Hold Time	t _{DH}	—	250	—	ns	
$\overline{\text{CS}}$ Setup Time	t _{CSS}	—	250	—	ns	
$\overline{\text{CS}}$ Hold Time	t _{CSH}	R ₁ =3.3kΩ, C ₁ =47pF	16	—	μs	
$\overline{\text{CS}}$ Wait Time	t _{CSW}	—	250	—	ns	
Data Processing Time	t _{DOFF}	R ₁ =3.3kΩ, C ₁ =47pF	8	—	μs	
$\overline{\text{RESET}}$ Pulse Width	t _{WRES}	When $\overline{\text{RESET}}$ signal is input from microcontroller etc. externally	250	—	ns	
$\overline{\text{RESET}}$ Time	t _{RSON}	When $\overline{\text{RESET}}$ signal is input from microcontroller etc. externally	250	—	ns	
		R ₂ =1.0kΩ, C ₂ =0.1μF	—	200	μs	
DA Wait Time	t _{RSOFF}	—	250	—	ns	
All Output Slew Rate	t _R	C _l =100pF	t _R =20% to 80%	—	2.0	μs
	t _F		t _F =80% to 20%	—	2.0	μs
V _{DD} Rise Time	t _{PRZ}	When mounted in the unit	—	100	μs	
V _{DD} Off Time	t _{POF}	When mounted in the unit, V _{DD} =0.0V	5.0	—	ms	

AC Characteristics-2

(V_{DD}=3.3V±10%, V_{FL}=-60V, T_a=-40 to +85°C, unless otherwise specified)

Parameter	Symbol	Condition	Min.	Max.	Unit	
$\overline{\text{CP}}$ Frequency	f _C	—	—	2.0	MHz	
$\overline{\text{CP}}$ Pulse Width	t _{CW}	—	250	—	ns	
DA Setup Time	t _{DS}	—	250	—	ns	
DA Hold Time	t _{DH}	—	250	—	ns	
$\overline{\text{CS}}$ Setup Time	t _{CSS}	—	250	—	ns	
$\overline{\text{CS}}$ Hold Time	t _{CSH}	R ₁ =3.3kΩ, C ₁ =39pF	16	—	μs	
$\overline{\text{CS}}$ Wait Time	t _{CSW}	—	250	—	ns	
Data Processing Time	t _{DOFF}	R ₁ =3.3kΩ, C ₁ =39pF	8	—	μs	
$\overline{\text{RESET}}$ Pulse Width	t _{WRES}	When $\overline{\text{RESET}}$ signal is input from microcontroller etc. externally	250	—	ns	
$\overline{\text{RESET}}$ Time	t _{RSON}	When $\overline{\text{RESET}}$ signal is input from microcontroller etc. externally	250	—	ns	
		R ₂ =1.0kΩ, C ₂ =0.1μF	—	200	μs	
DA Wait Time	t _{RSOFF}	—	250	—	ns	
All Output Slew Rate	t _R	C _l =100pF	t _R =20% to 80%	—	2.0	μs
	t _F		t _F =80% to 20%	—	2.0	μs
V _{DD} Rise Time	t _{PRZ}	When mounted in the unit	—	100	μs	
V _{DD} Off Time	t _{POF}	When mounted in the unit, V _{DD} =0.0V	5.0	—	ms	

TIMING DIAGRAM

Symbol	V _{DD} =3.3V±10%	V _{DD} =5.0V±10%
V _{IH}	0.8 V _{DD}	0.7 V _{DD}
V _{IL}	0.2 V _{DD}	0.3 V _{DD}

• Data Timing

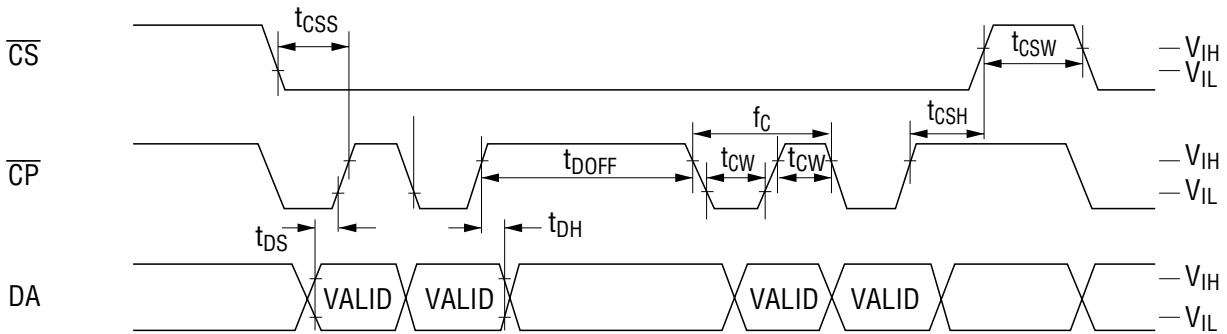

• Reset Timing

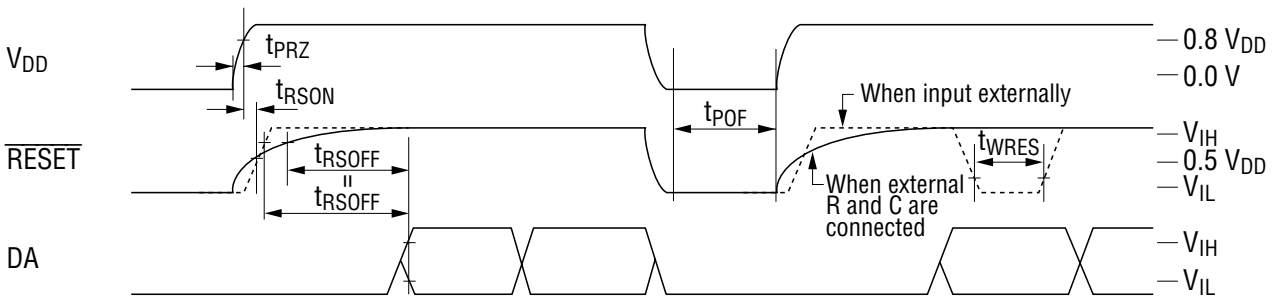

• Output Timing

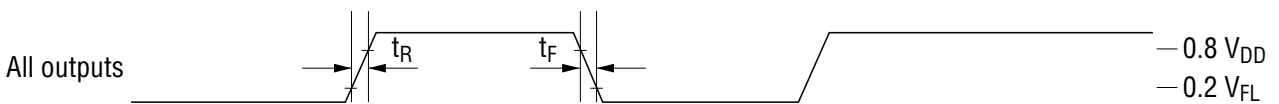

• Digit Output Timing (for 16-digit display, at a duty of 240/256)

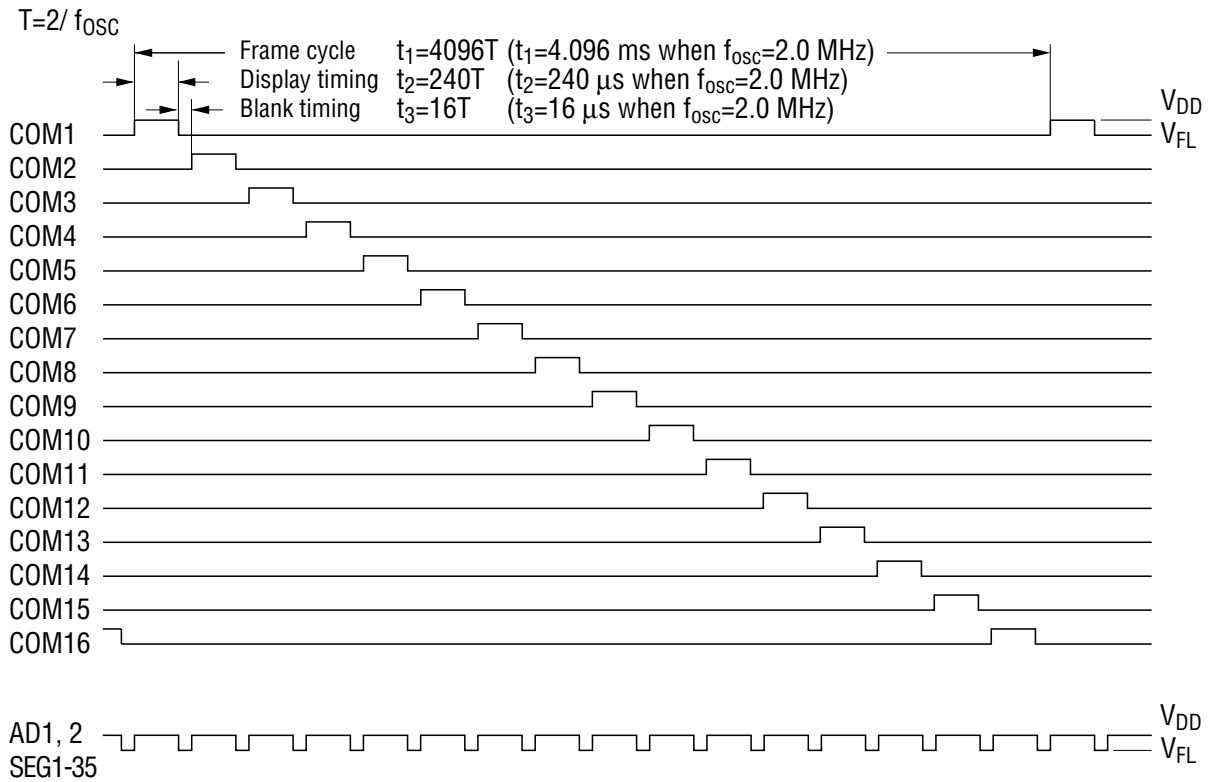

FUNCTIONAL DESCRIPTION

Commands List

	Command	1st byte								2nd byte								
		LSB								MSB	LSB							
		B0	B1	B2	B3	B4	B5	B6	B7	B0	B1	B2	B3	B4	B5	B6	B7	
1	DCRAM data write	X0	X1	X2	X3	1	0	0	0	C0	C1	C2	C3	C4	C5	C6	C7	
2	CGRAM data write	X0	X1	X2	*	0	1	0	0	C0	C5	C10	C15	C20	C25	C30	*	2nd byte
										C1	C6	C11	C16	C21	C26	C31	*	3rd byte
										C2	C7	C12	C17	C22	C27	C32	*	4th byte
										C3	C8	C13	C18	C23	C28	C33	*	5th byte
										C4	C9	C14	C19	C24	C29	C34	*	6th byte
3	ADRAM data write	X0	X1	X2	X3	1	1	0	0	C0	C1	*	*	*	*	*	*	
4	General output port set	P1	P2	*	*	0	0	1	0									
5	Display duty set	*	*	*	*	1	0	1	0	D0	D1	D2	D3	D4	D5	D6	D7	
6	Number of digits set	K0	K1	K2	*	0	1	1	0	* : Don't care								
7	All lights ON/OFF	L	H	*	*	1	1	1	0	Xn : Address specification for each RAM								
	Test mode									Cn : Character code specification for each RAM								
										Pn : General output port status specification								
										Dn : Display duty specification								
										Kn : Number of digits specification								
										H : All lights ON instruction								
										L : All lights OFF instruction								

When data is written to RAM (DCRAM, CGRAM, ADRAM) continuously, addresses are internally incremented automatically. Therefore it is not necessary to specify the 1st byte to write RAM data for the 2nd and later bytes.

Note: The test mode is used for inspection before shipment. It is not a user function.

Positional Relationship Between SEGn and ADn (one digit)

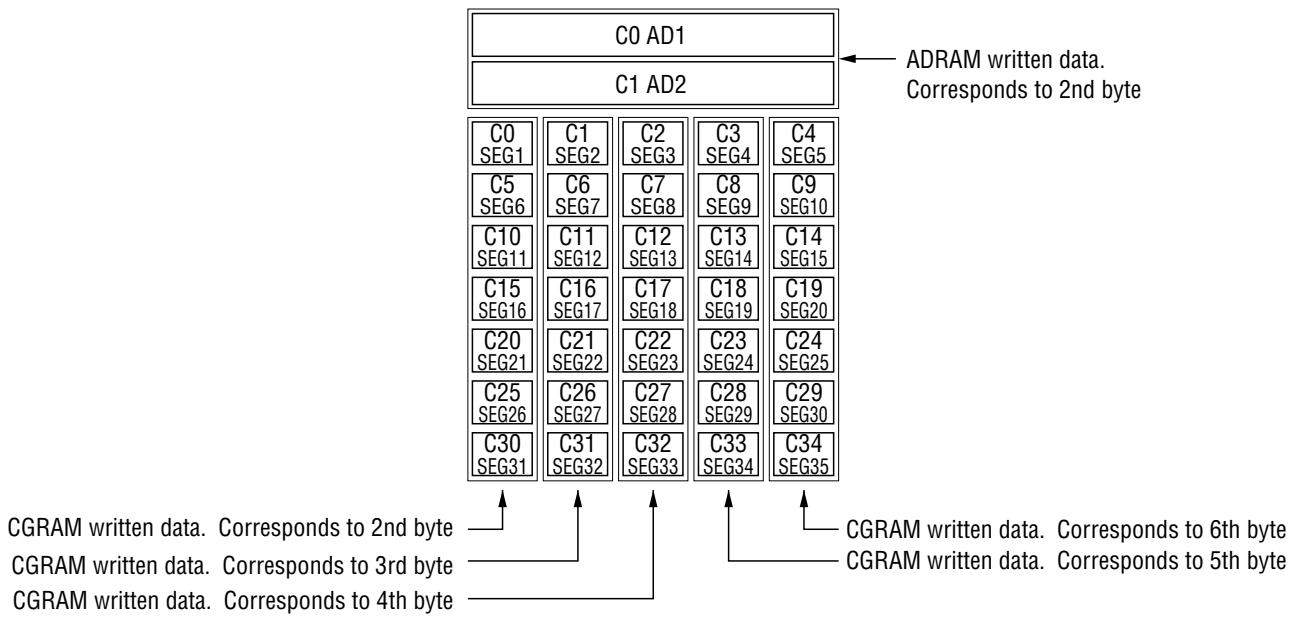

Data Transfer Method and Command Write Method

Display control command and data are written by an 8-bit serial transfer. Write timing is shown in the figure below.

Setting the \overline{CS} pin to "Low" level enables a data transfer. Data is 8 bits and is sequentially input into the DA pin from LSB (LSB first). As shown in the figure below, data is read by the shift register at the rising edge of the shift clock, which is input into the \overline{CP} pin. If 8-bit data is input, internal load signals are automatically generated and data is written to each register and RAM. Therefore it is not necessary to input load signals from the outside.

Setting the \overline{CS} pin to "High" disables data transfer. Data input from the point when the \overline{CS} pin changes from "High" to "Low" is recognized in 8-bit units.

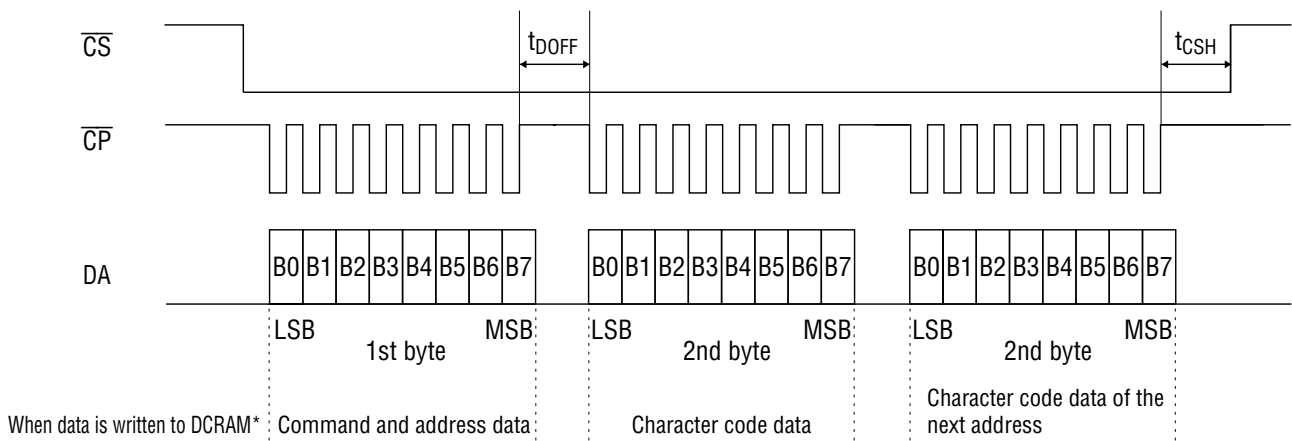

* When data is written to RAM (DCRAM, ADRAM, CGRAM) continuously, addresses are internally incremented automatically. Therefore it is not necessary to specify the 1st byte to write RAM data for the 2nd and later bytes.

Reset Function

Reset is executed when the \overline{RESET} pin is set to "L", (when turning power on, for example) and initializes all functions.

Initial status is as follows.

- Address of each RAM address "00"H
- Data of each RAM All contents are undefined
- General output port All general output ports go "Low"
- Display digit 16 digits
- Brightness adjustment 0/256
- All display lights ON or OFF OFF mode
- Segment output All segment outputs go "Low"
- AD output All AD outputs go "Low"

Please set again according to "Setting Flowchart" after reset.

Description of Commands and Functions

1. DCRAM data write
(Specifies the address of DCRAM and writes the character code of CGROM and CGRAM.)

DCRAM (Data Control RAM) has a 4-bit address to store character code of CGROM and CGRAM.

The character code specified by DCRAM is converted to a 5×7 dot matrix character pattern via CGROM or CGRAM.

(The DCRAM can store 16 characters.)

[Command format]

	LSB	B0	B1	B2	B3	B4	B5	B6	MSB	B7	
1st byte (1st)	X0	X1	X2	X3	1	0	0	0			: selects DCRAM data write mode and specifies DCRAM address (Ex: Specifies DCRAM address 0H)

	LSB	B0	B1	B2	B3	B4	B5	B6	MSB	B7	
2nd byte (2nd)	C0	C1	C2	C3	C4	C5	C6	C7			: specifies character code of CGROM and CGRAM (written into DCRAM address 0H)

To specify the character code of CGROM and CGRAM continuously to the next address, specify only character code as follows.

The addresses of DCRAM are automatically incremented. Specification of the 1st byte is unnecessary.

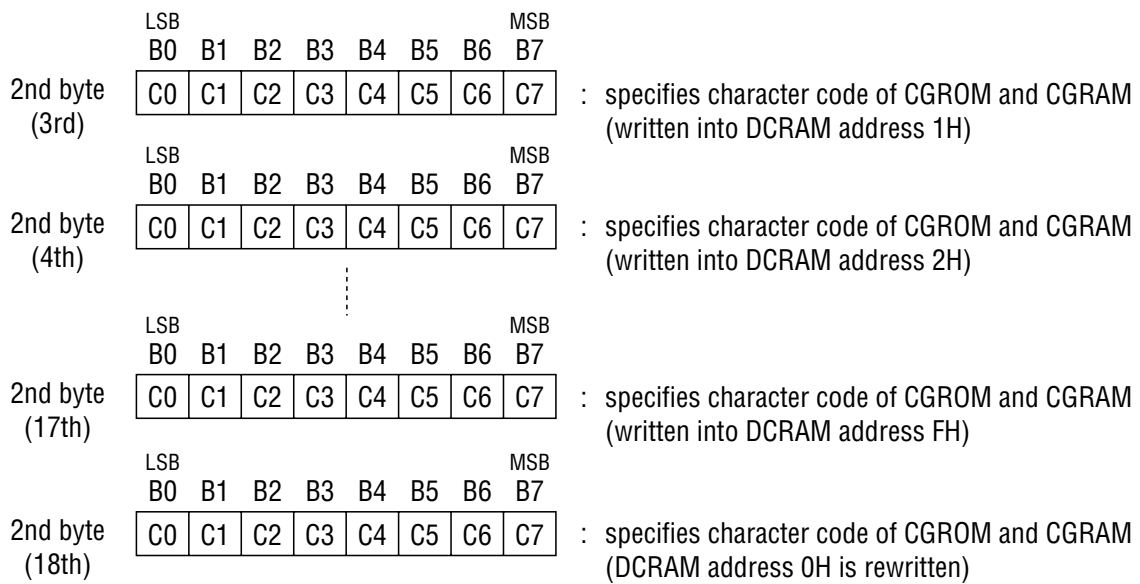

X0 (LSB) to X3 (MSB): DCRAM addresses (4 bits: 16 characters)

C0 (LSB) to C7 (MSB): Character code of CGROM and CGRAM (8 bits: 256 characters)

[COM positions and set DCRAM addresses]

HEX	X0	X1	X2	X3	COM position
0	0	0	0	0	COM1
1	1	0	0	0	COM2
2	0	1	0	0	COM3
3	1	1	0	0	COM4
4	0	0	1	0	COM5
5	1	0	1	0	COM6
6	0	1	1	0	COM7
7	1	1	1	0	COM8
8	0	0	0	1	COM9
9	1	0	0	1	COM10
A	0	1	0	1	COM11
B	1	1	0	1	COM12
C	0	0	1	1	COM13
D	1	0	1	1	COM14
E	0	1	1	1	COM15
F	1	1	1	1	COM16

2. CGRAM data write
(Specifies the addresses of CGRAM and writes character pattern data.)

CGRAM (Character Generator RAM) has a 3-bit address to store 5×7 dot matrix character patterns.

A character pattern stored in CGRAM can be displayed by specifying the character code (address) by DCRAM.

The address of CGRAM is assigned to 00H to 07H. (All the other addresses are the CGROM addresses.)

(The CGRAM can store 8 types of character patterns.)

[Command format]

	LSB B0 B1 B2 B3 B4 B5 B6 B7 MSB									
1st byte (1st)	<table border="1" style="border-collapse: collapse; width: 100%;"> <tr> <td style="width: 12.5%;">X0</td> <td style="width: 12.5%;">X1</td> <td style="width: 12.5%;">X2</td> <td style="width: 12.5%;">*</td> <td style="width: 12.5%;">0</td> <td style="width: 12.5%;">1</td> <td style="width: 12.5%;">0</td> <td style="width: 12.5%;">0</td> </tr> </table>	X0	X1	X2	*	0	1	0	0	: selects CGRAM data write mode and specifies CGRAM address. (Ex: specifies CGRAM address 00H)
X0	X1	X2	*	0	1	0	0			
2nd byte (2nd)	LSB B0 B1 B2 B3 B4 B5 B6 B7 MSB									
	<table border="1" style="border-collapse: collapse; width: 100%;"> <tr> <td style="width: 12.5%;">C0</td> <td style="width: 12.5%;">C5</td> <td style="width: 12.5%;">C10</td> <td style="width: 12.5%;">C15</td> <td style="width: 12.5%;">C20</td> <td style="width: 12.5%;">C25</td> <td style="width: 12.5%;">C30</td> <td style="width: 12.5%;">*</td> </tr> </table>	C0	C5	C10	C15	C20	C25	C30	*	: specifies 1st column data (rewritten into CGRAM address 00H)
C0	C5	C10	C15	C20	C25	C30	*			
3rd byte (3rd)	LSB B0 B1 B2 B3 B4 B5 B6 B7 MSB									
	<table border="1" style="border-collapse: collapse; width: 100%;"> <tr> <td style="width: 12.5%;">C1</td> <td style="width: 12.5%;">C6</td> <td style="width: 12.5%;">C11</td> <td style="width: 12.5%;">C16</td> <td style="width: 12.5%;">C21</td> <td style="width: 12.5%;">C26</td> <td style="width: 12.5%;">C31</td> <td style="width: 12.5%;">*</td> </tr> </table>	C1	C6	C11	C16	C21	C26	C31	*	: specifies 2nd column data (rewritten into CGRAM address 00H)
C1	C6	C11	C16	C21	C26	C31	*			
4th byte (4th)	LSB B0 B1 B2 B3 B4 B5 B6 B7 MSB									
	<table border="1" style="border-collapse: collapse; width: 100%;"> <tr> <td style="width: 12.5%;">C2</td> <td style="width: 12.5%;">C7</td> <td style="width: 12.5%;">C12</td> <td style="width: 12.5%;">C17</td> <td style="width: 12.5%;">C22</td> <td style="width: 12.5%;">C27</td> <td style="width: 12.5%;">C32</td> <td style="width: 12.5%;">*</td> </tr> </table>	C2	C7	C12	C17	C22	C27	C32	*	: specifies 3rd column data (rewritten into CGRAM address 00H)
C2	C7	C12	C17	C22	C27	C32	*			
5th byte (5th)	LSB B0 B1 B2 B3 B4 B5 B6 B7 MSB									
	<table border="1" style="border-collapse: collapse; width: 100%;"> <tr> <td style="width: 12.5%;">C3</td> <td style="width: 12.5%;">C8</td> <td style="width: 12.5%;">C13</td> <td style="width: 12.5%;">C18</td> <td style="width: 12.5%;">C23</td> <td style="width: 12.5%;">C28</td> <td style="width: 12.5%;">C33</td> <td style="width: 12.5%;">*</td> </tr> </table>	C3	C8	C13	C18	C23	C28	C33	*	: specifies 4th column data (rewritten into CGRAM address 00H)
C3	C8	C13	C18	C23	C28	C33	*			
6th byte (6th)	LSB B0 B1 B2 B3 B4 B5 B6 B7 MSB									
	<table border="1" style="border-collapse: collapse; width: 100%;"> <tr> <td style="width: 12.5%;">C4</td> <td style="width: 12.5%;">C9</td> <td style="width: 12.5%;">C14</td> <td style="width: 12.5%;">C19</td> <td style="width: 12.5%;">C24</td> <td style="width: 12.5%;">C29</td> <td style="width: 12.5%;">C34</td> <td style="width: 12.5%;">*</td> </tr> </table>	C4	C9	C14	C19	C24	C29	C34	*	: specifies 5th column data (rewritten into CGRAM address 00H)
C4	C9	C14	C19	C24	C29	C34	*			

To specify character pattern data continuously to the next address, specify only character pattern data as follows.

The addresses of CGRAM are automatically incremented. Specification of the 1st byte is therefore unnecessary.

The 2nd to 6th byte (character pattern data) are regarded as one data item, so 300 ns is sufficient for t_{DOFF} time between bytes.

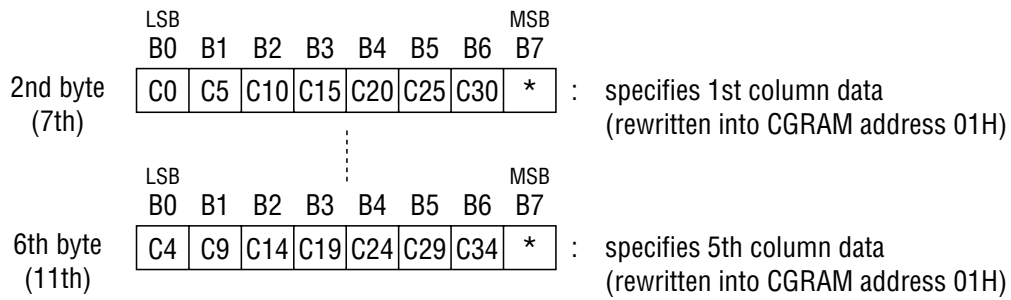

X0 (LSB) to X2 (MSB): CGRAM addresses (3 bits: 8 characters)
 C0 (LSB) to C34 (MSB): Character pattern data (35 bits: 35 outputs per digit)
 * : Don't care

[CGROM addresses and set CGRAM addresses]

Refer to ROMCODE table

HEX	X0	X1	X2	CGROM address
00	0	0	0	RAM00(00000000B)
01	1	0	0	RAM01(00000001B)
02	0	1	0	RAM02(00000010B)
03	1	1	0	RAM03(00000011B)
04	0	0	1	RAM04(00000100B)
05	1	0	1	RAM05(00000101B)
06	0	1	1	RAM06(00000110B)
07	1	1	1	RAM07(00000111B)

Positional relationship between the output area of CGROM and that of CGRAM

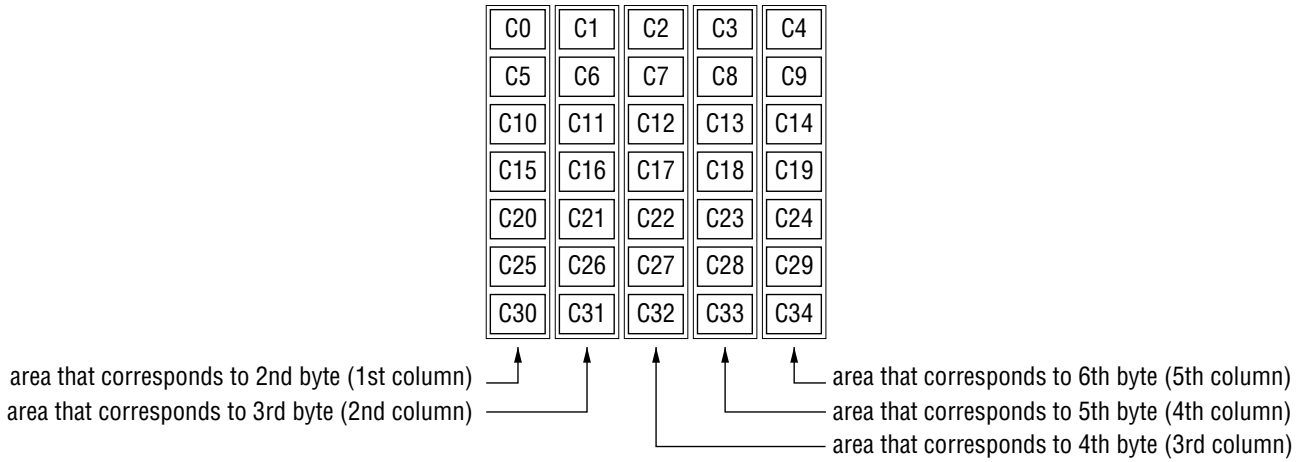

Note: CGROM (Character Generator ROM) has an 8-bit address to generate 5x7 dot matrix character patterns.
 CGRAM can store 248 types of character patterns.
 General-purpose code -01 is available (see ROM CODE list) and custom codes are provided on customer's request.

3. ADRAM data write
(specifies address of ADRAM and writes symbol data)

ADRAM (Additional Data RAM) has a 2-bit address to store symbol data.
Symbol data specified by ADRAM is directly output without CGROM and CGRAM.
(The ADRAM can store 2 types of symbol patterns for each digit.)
The terminal to which the contents of ADRAM are output can be used as a cursor.

[Command format]

	LSB				MSB				
	B0	B1	B2	B3	B4	B5	B6	B7	
1st byte (1st)	X0	X1	X2	X3	1	1	0	0	: selects ADRAM data write mode and specifies ADRAM address (Ex: specifies ADRAM address 0H)
	LSB				MSB				
	B0	B1	B2	B3	B4	B5	B6	B7	
2nd byte (2nd)	C0	C1	*	*	*	*	*	*	: sets symbol data (written into ADRAM address 0H)

To specify symbol data continuously to the next address, specify only symbol data as follows.
The address of ADRAM is automatically incremented. Specification of the 1st byte is therefore unnecessary.

	LSB				MSB				
	B0	B1	B2	B3	B4	B5	B6	B7	
2nd byte (3rd)	C0	C1	*	*	*	*	*	*	: sets symbol data (written into ADRAM address 1H)
	LSB				MSB				
	B0	B1	B2	B3	B4	B5	B6	B7	
2nd byte (4th)	C0	C1	*	*	*	*	*	*	: sets symbol data (written into ADRAM address 2H)
				⋮					
	LSB				MSB				
	B0	B1	B2	B3	B4	B5	B6	B7	
2nd byte (17th)	C0	C1	*	*	*	*	*	*	: sets symbol data (written into ADRAM address FH)
	LSB				MSB				
	B0	B1	B2	B3	B4	B5	B6	B7	
2nd byte (18th)	C0	C1	*	*	*	*	*	*	: sets symbol data (ADRAM address 0H is rewritten.)

X0 (LSB) to X3 (MSB): ADRAM addresses (4 bits: 16 characters)
C0 (LSB) to C1 (MSB): Symbol data (2 bits: 2-symbol data per digit)
* : Don't care

[COM positions and ADRAM addresses]

HEX	X0	X1	X2	X3	COM position
0	0	0	0	0	COM1
1	1	0	0	0	COM2
2	0	1	0	0	COM3
3	1	1	0	0	COM4
4	0	0	1	0	COM5
5	1	0	1	0	COM6
6	0	1	1	0	COM7
7	1	1	1	0	COM8
8	0	0	0	1	COM9
9	1	0	0	1	COM10
A	0	1	0	1	COM11
B	1	1	0	1	COM12
C	0	0	1	1	COM13
D	1	0	1	1	COM14
E	0	1	1	1	COM15
F	1	1	1	1	COM16

4. General output port set
(specifies the general output port status)

The general output port is an output for 2-bit static operation.

It is used to control other I/O devices and turn on LED. (static operation)

When at the "High" level, this output becomes the V_{DD} voltage, and when at the "Low" level, it becomes the ground potential. Therefore, the fluorescent display tube cannot be driven.

[Command format]

	LSB							MSB		
	B0	B1	B2	B3	B4	B5	B6	B7		
1st byte	P1	P2	*	*	0	0	1	0	: selects a general output port and specifies the output status	

P1, P2 : general output port

* : don't care

[Set data and set state of general output port]

P1	P2	Display state of general output port
0	0	Sets P1 and P2 to low
1	0	Sets P1 to high and P2 to low
0	1	Sets P1 to low and P2 to high
1	1	Sets P1 and P2 to high

(The state when power is applied or when $\overline{\text{RESET}}$ is input.)

5. Display duty set
(writes display duty value to duty cycle register)

Display duty adjusts brightness in 256 stages using 8-bit data. (maximum brightness=240/256)
When power is turned on or when the RESET signal is input, the duty cycle register value is "0". Always execute this instruction before turning the display on, then set a desired duty value.

[Command format]

	LSB							MSB	
	B0	B1	B2	B3	B4	B5	B6	B7	
1st byte	*	*	*	*	1	0	1	0	: selects display duty set mode and sets duty value

	LSB							MSB	
	D0	D1	D2	D3	D4	D5	D6	D7	
2nd byte	D0	D1	D2	D3	D4	D5	D6	D7	: Sets display duty value

D0 (LSB) to D7 (MSB) : display duty data (8 bits: 256 stages)
* : don't care

[Relation between setup data and controlled COM duty]

HEX	D0	D1	D2	D3	D4	D5	D6	D7	COM duty
00	0	0	0	0	0	0	0	0	0/256
01	1	0	0	0	0	0	0	0	1/256
02	0	1	0	0	0	0	0	0	2/256
⋮									⋮
F7	1	1	1	0	1	1	1	1	239/256
F8	0	0	0	1	1	1	1	1	240/256
⋮									⋮
FF	1	1	1	1	1	1	1	1	240/256

*The state when power is turned on or when RESET signal is input.

} No brightness change due to fixed blank time (16/256)

6. Number of digits set
(writes the number of display digits to the display digit register)

The number of digits set can display 1 to 16 digits using 4-bit data.
When power is turned on or when a $\overline{\text{RESET}}$ signal is input, the number of digit register value is "0". Always execute this instruction to change the number of digits before turning the display on.

[Command format]

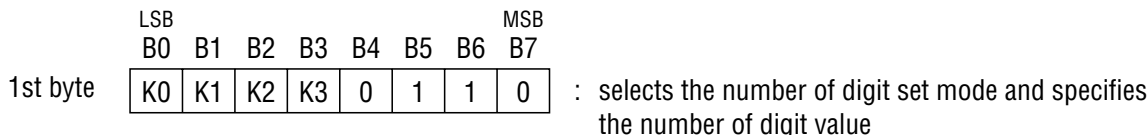

K0 (LSB) to K3 (MSB) : number of digit data (4 bits: 16 digits)
* : don't care

[Relation between setup data and controlled COM]

HEX	K0	K1	K2	K3	Number of digits of COM	HEX	K0	K1	K2	K3	Number of digits of COM
0	0	0	0	0	COM1 to 16	8	0	0	0	1	COM1 to 8
1	1	0	0	0	COM1	9	1	0	0	1	COM1 to 9
2	0	1	0	0	COM1 to 2	A	0	1	0	1	COM1 to 10
3	1	1	0	0	COM1 to 3	B	1	1	0	1	COM1 to 11
4	0	0	1	0	COM1 to 4	C	0	0	1	1	COM1 to 12
5	1	0	1	0	COM1 to 5	D	1	0	1	1	COM1 to 13
6	0	1	1	0	COM1 to 6	E	0	1	1	1	COM1 to 14
7	1	1	1	0	COM1 to 7	F	1	1	1	1	COM1 to 15

*The state when power is turned on or when $\overline{\text{RESET}}$ signal is input.

- 7. All display lights ON/OFF set
(turns all display lights ON or OFF)

All display lights ON is used primarily for display testing.

All display lights OFF is primarily used for display blink and to prevent malfunction when power is turned on.

This command cannot control the general output port.

[Command format]

	LSB							MSB		
	B0	B1	B2	B3	B4	B5	B6	B7		
1st byte	L	H	*	*	1	1	1	0	: selects all display lights ON or OFF mode	

L: sets all lights OFF

H: sets all lights ON

*: Don't care

[Set data and display state of SEG and AD]

L	H	Display state of SEG and AD
0	0	Normal display
1	0	Sets all outputs to Low
0	1	Sets all outputs to High
1	1	Sets all outputs to High

(The state when power is applied or when $\overline{\text{RESET}}$ is input.)

(All lights ON mode has priority.)

**Setting Flowchart
(Power applying included)**

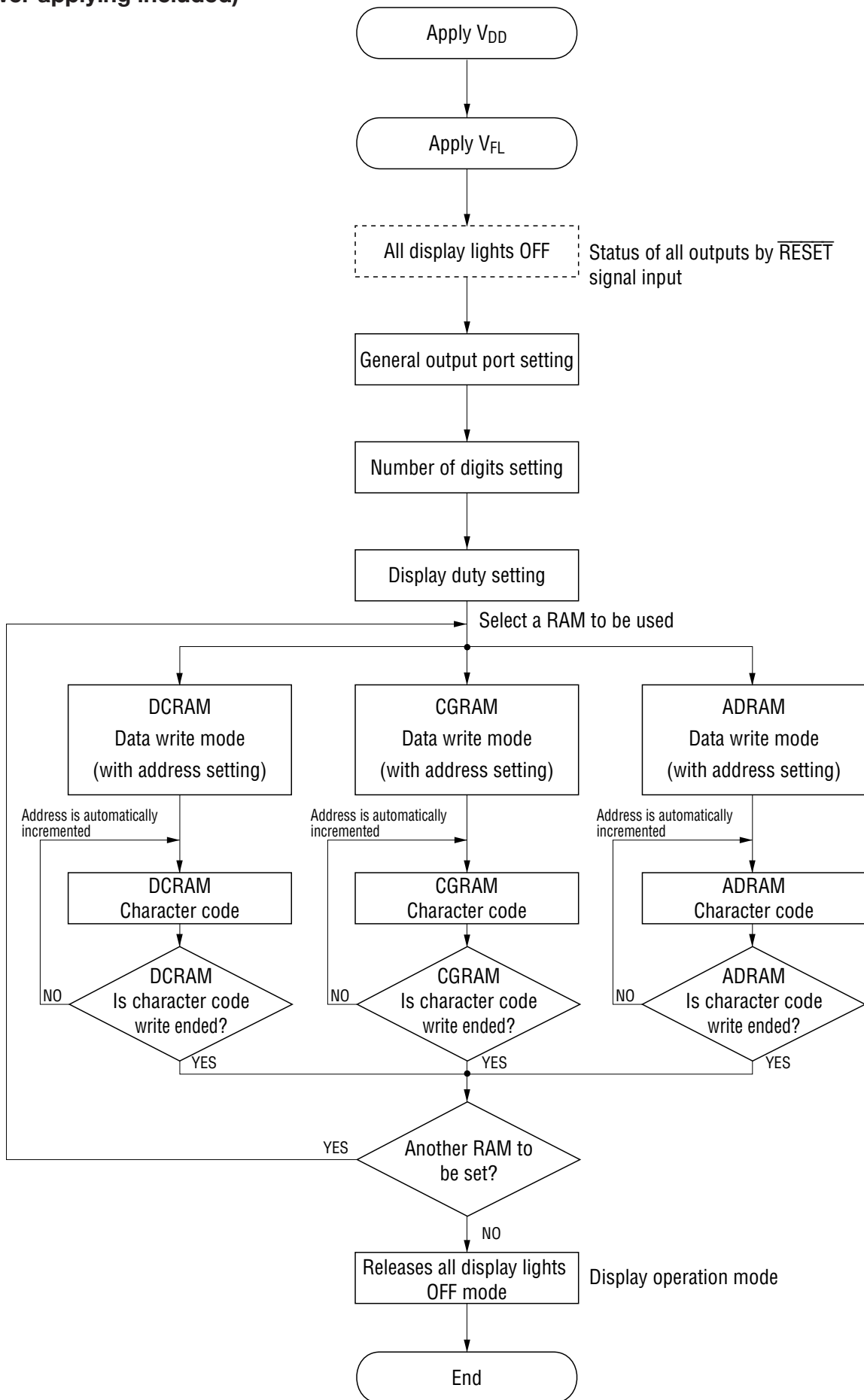

Power-off Flowchart

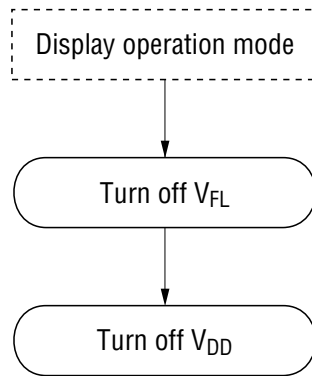

APPLICATION CIRCUIT

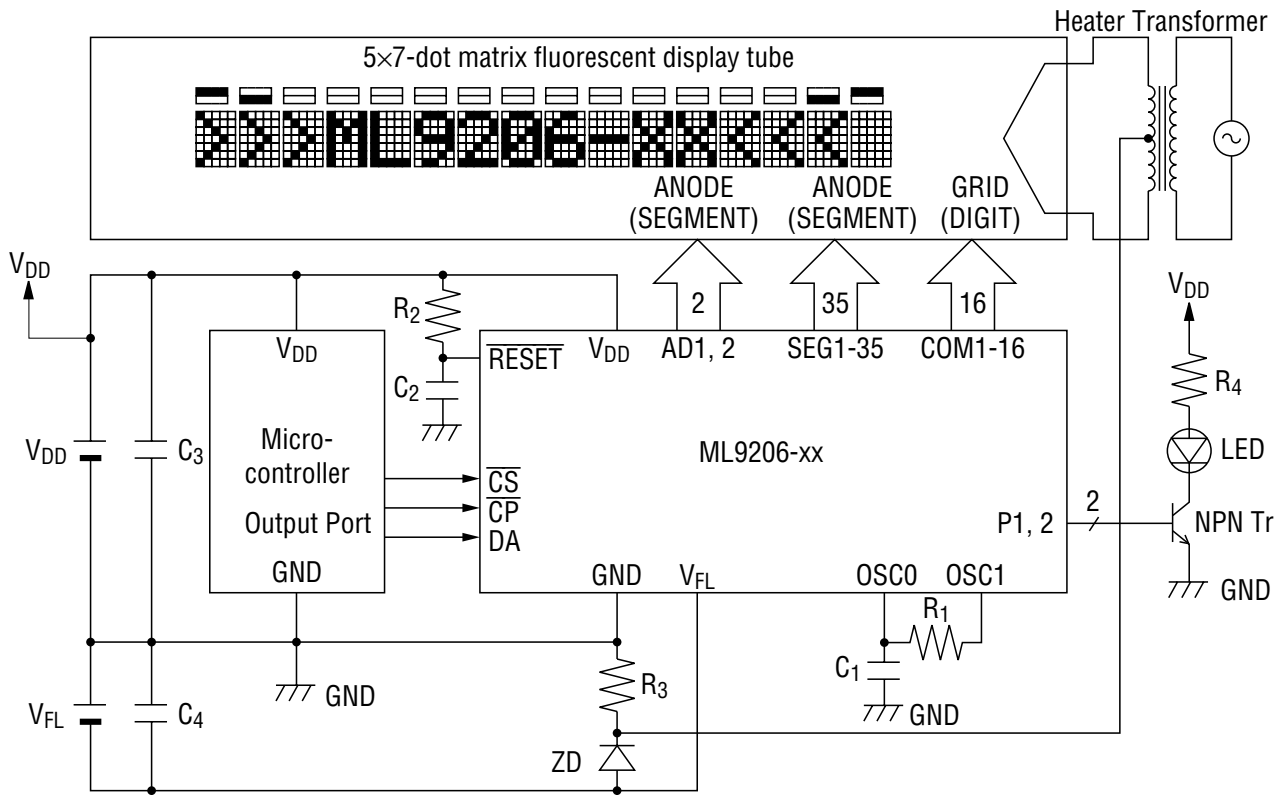

- Notes:
1. The V_{DD} value depends on the power supply voltage of the microcontroller used. Adjust the values of the constants R_1 , R_2 , R_4 , C_1 , and C_2 to the power supply voltage used.
 2. The V_{FL} value depends on the fluorescent display tube used. Adjust the values of the constants R_3 and ZD to the power supply voltage used.

Reference data

The figure below shows the relationship between the V_{FL} voltage and the output current of each driver.

Take care that the total power consumption to be used does not exceed the power dissipation.

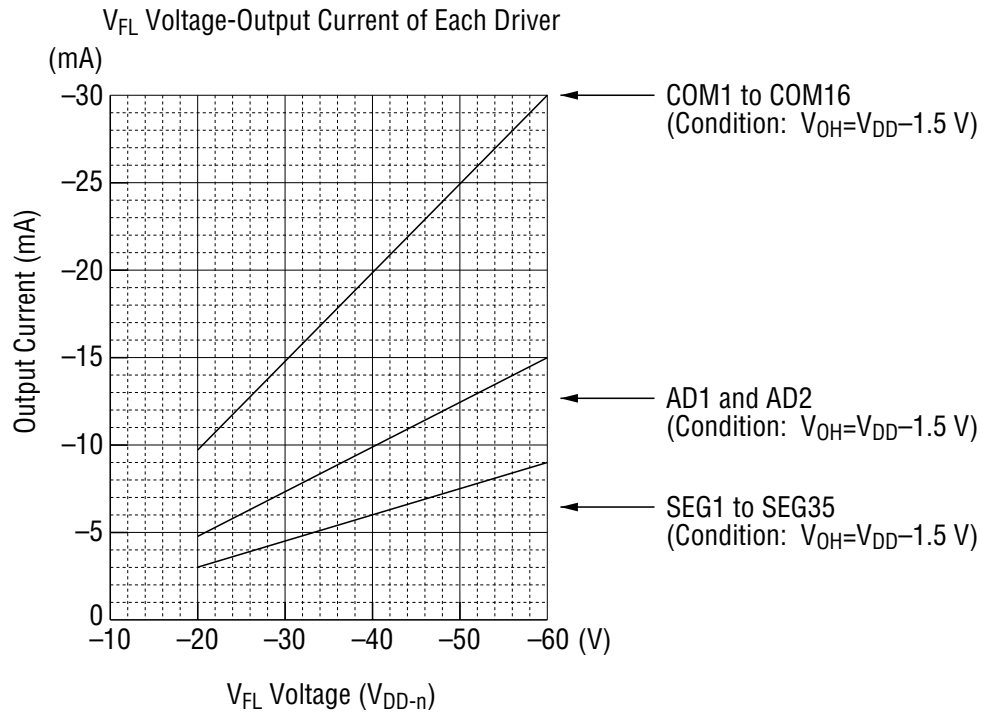

ML9206-01 ROM Code

00000000B (00H) to 00000111B (07H) are the CGRAM addresses.

MSB LSB	0000	0001	0010	0011	0100	0101	0110	0111	1000	1001	1010	1011	1100	1101	1110	1111
0000	RAM0															
0001	RAM1															
0010	RAM2															
0011	RAM3															
0100	RAM4															
0101	RAM5															
0110	RAM6															
0111	RAM7															
1000																
1001																
1010																
1011																
1100																
1101																
1110																
1111																

PACKAGE DIMENSIONS

(Unit : mm)

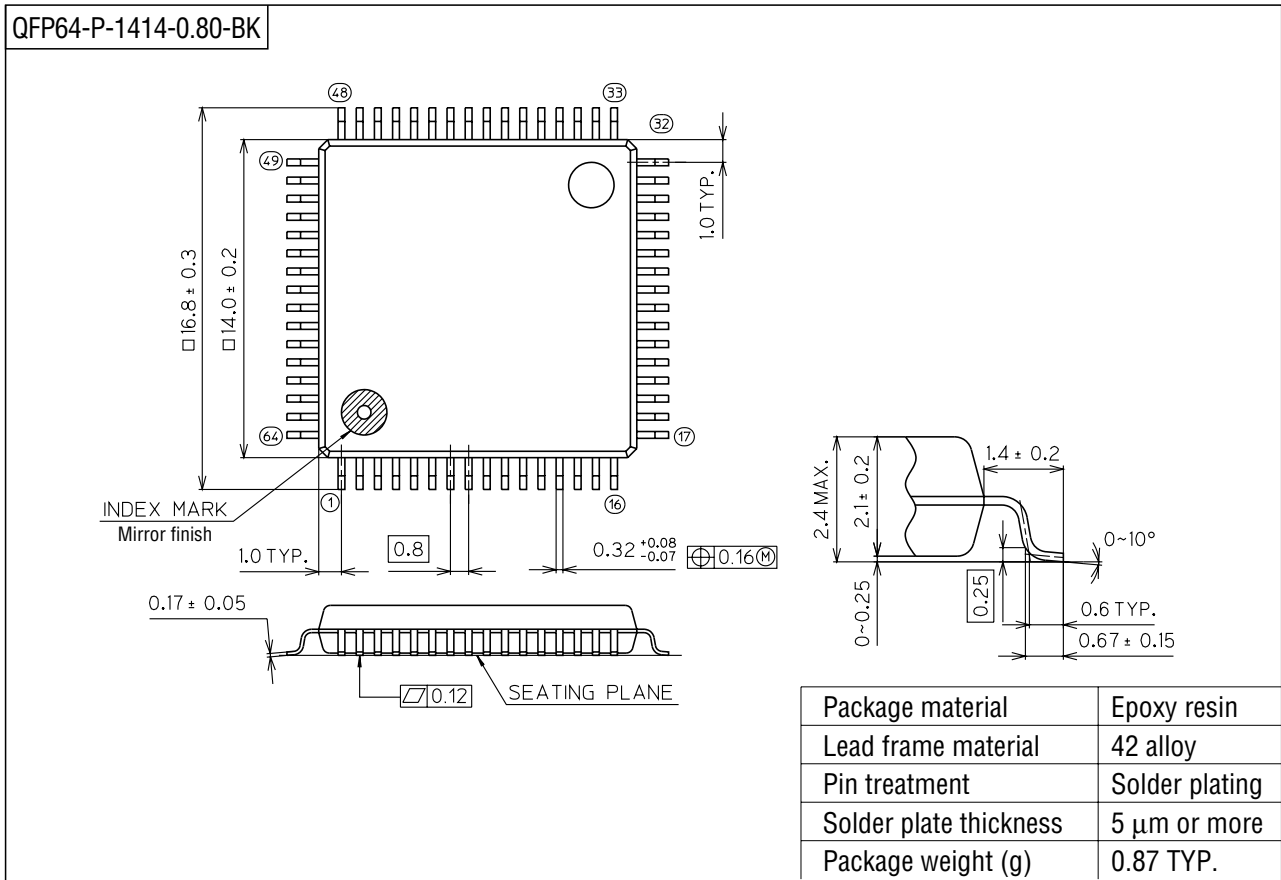

Notes for Mounting the Surface Mount Type Package

The SOP, QFP, TSOP, TQFP, LQFP, SOJ, QFJ (PLCC), SHP, and BGA are surface mount type packages, which are very susceptible to heat in reflow mounting and humidity absorbed in storage. Therefore, before you perform reflow mounting, contact Oki's responsible sales person on the product name, package name, pin number, package code and desired mounting conditions (reflow method, temperature and times).

(Unit : mm)

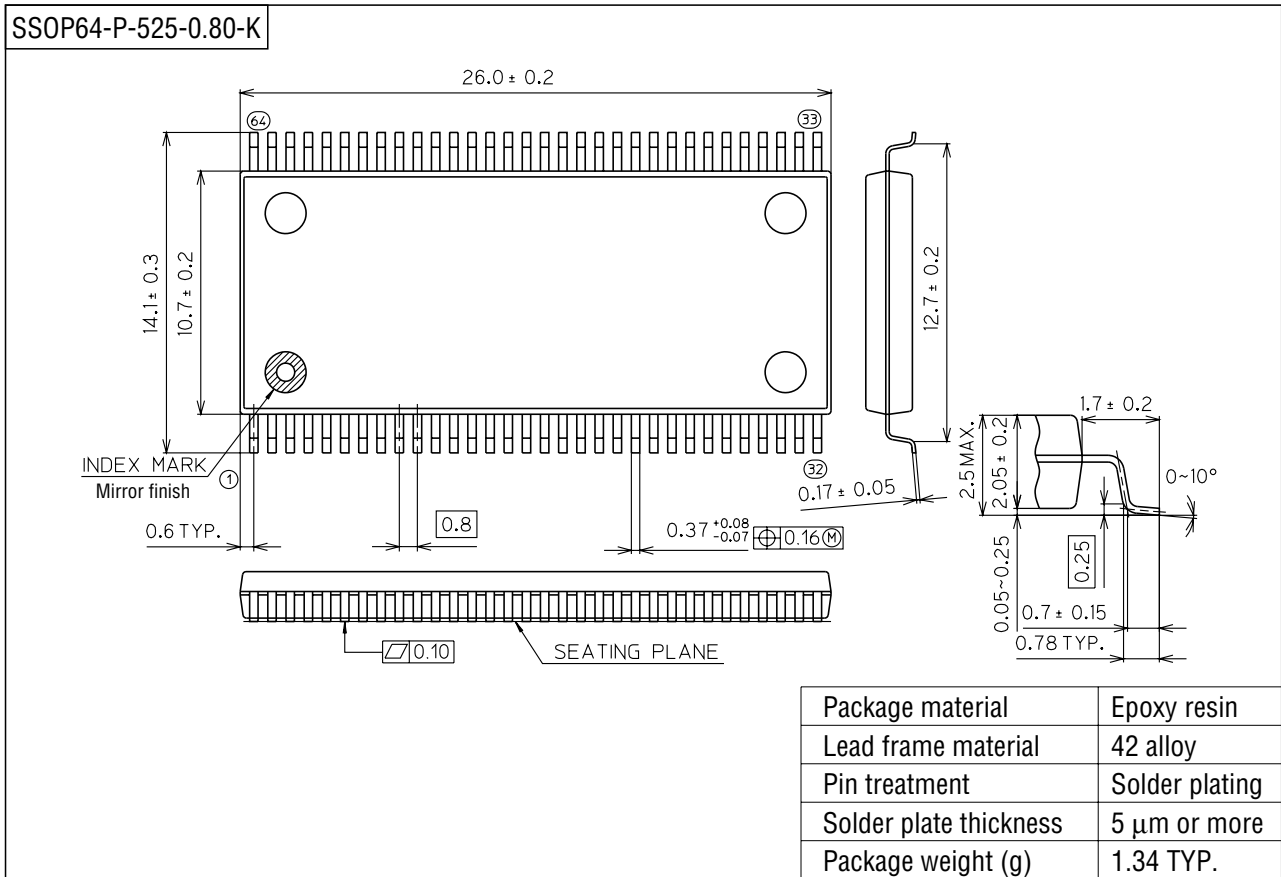

Notes for Mounting the Surface Mount Type Package

The SOP, QFP, TSOP, TQFP, LQFP, SOJ, QFJ (PLCC), SHP, and BGA are surface mount type packages, which are very susceptible to heat in reflow mounting and humidity absorbed in storage. Therefore, before you perform reflow mounting, contact Oki's responsible sales person on the product name, package name, pin number, package code and desired mounting conditions (reflow method, temperature and times).

NOTICE

1. The information contained herein can change without notice owing to product and/or technical improvements. Before using the product, please make sure that the information being referred to is up-to-date.
2. The outline of action and examples for application circuits described herein have been chosen as an explanation for the standard action and performance of the product. When planning to use the product, please ensure that the external conditions are reflected in the actual circuit, assembly, and program designs.
3. When designing your product, please use our product below the specified maximum ratings and within the specified operating ranges including, but not limited to, operating voltage, power dissipation, and operating temperature.
4. Oki assumes no responsibility or liability whatsoever for any failure or unusual or unexpected operation resulting from misuse, neglect, improper installation, repair, alteration or accident, improper handling, or unusual physical or electrical stress including, but not limited to, exposure to parameters beyond the specified maximum ratings or operation outside the specified operating range.
5. Neither indemnity against nor license of a third party's industrial and intellectual property right, etc. is granted by us in connection with the use of the product and/or the information and drawings contained herein. No responsibility is assumed by us for any infringement of a third party's right which may result from the use thereof.
6. The products listed in this document are intended for use in general electronics equipment for commercial applications (e.g., office automation, communication equipment, measurement equipment, consumer electronics, etc.). These products are not authorized for use in any system or application that requires special or enhanced quality and reliability characteristics nor in any system or application where the failure of such system or application may result in the loss or damage of property, or death or injury to humans. Such applications include, but are not limited to, traffic and automotive equipment, safety devices, aerospace equipment, nuclear power control, medical equipment, and life-support systems.
7. Certain products in this document may need government approval before they can be exported to particular countries. The purchaser assumes the responsibility of determining the legality of export of these products and will take appropriate and necessary steps at their own expense for these.
8. No part of the contents contained herein may be reprinted or reproduced without our prior permission.
9. MS-DOS is a registered trademark of Microsoft Corporation.

Copyright 1999 Oki Electric Industry Co., Ltd.