MR27V1652D

1,048,576-Word x 16-Bit or 2,097,152-Word x 8-Bit

8-Word x 16-Bit or 16-Word x 8-Bit Page Mode One Time PROM

DESCRIPTION

The MR27V1652D is a 16Mbit electrically Programmable Read-Only Memory with page mode. Its configuration can be electrically switched between 1,048,576 word x 16bit and 2,097,152 word x 8 bit. The MR27V1652D operates on a single +3.3V power supply and is TTL compatible. The MR27V1652D provides Page mode which can greatly reduce the read access time. Since the MR27V1652D operates asynchronously, external clocks are not required, making this device easy-to-use. The MR27V1652D is suitable as large-capacity fixed memory for microcomputers and data terminals. It is manufactured using a CMOS double silicon gate technology and is offered in 42-pin DIP, 44-pin SOP, 44-pin TSOP or 48-pin TSOP packages.

FEATURES

- 1,048,576 word x 16bit / 2,097,152 word x 8bit electrically switchable configuration
- Single +3.3V power supply
- Access time 80ns
Page mode access time 30ns
- Input / Output TTL compatible
- Three-state output
- Packages

42-pin plastic DIP (DIP42-P-600-2.54)

(Product name : MR27V1652DRA)

44-pin plastic SOP (SOP44-P-600-1.27-K)

(Product name : MR27V1652DMA)

44-pin plastic TSOP (TSOP II 44-P-400-0.80-K)

(Product name : MR27V1652DTP)

48-pin plastic TSOP (TSOP II 48-P-550-0.80-K)

(Product name : MR27V1652DTA)

PIN CONFIGURATION (TOP VIEW)

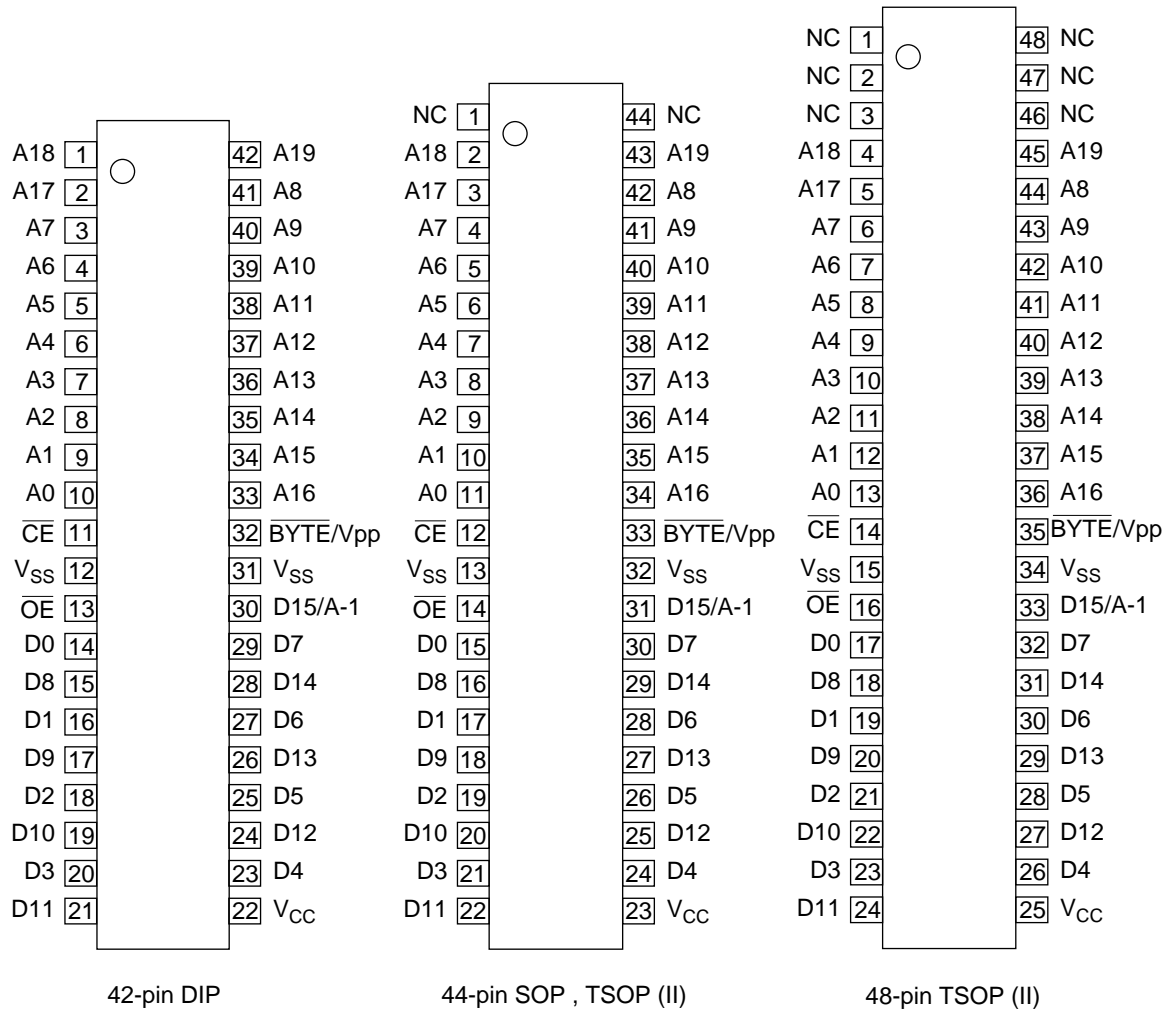

PIN NAMES	FUNCTIONS
D15/A-1	Data output / Address input
A0 - A19	Address input
D0 - D14	Data output
\overline{CE}	Chip enable
\overline{OE}	Output enable
V _{CC}	Power supply voltage
V _{SS}	GND
BYTE/V _{PP}	Mode switch / Program power supply voltage
NC	Non connection

BLOCK DIAGRAM

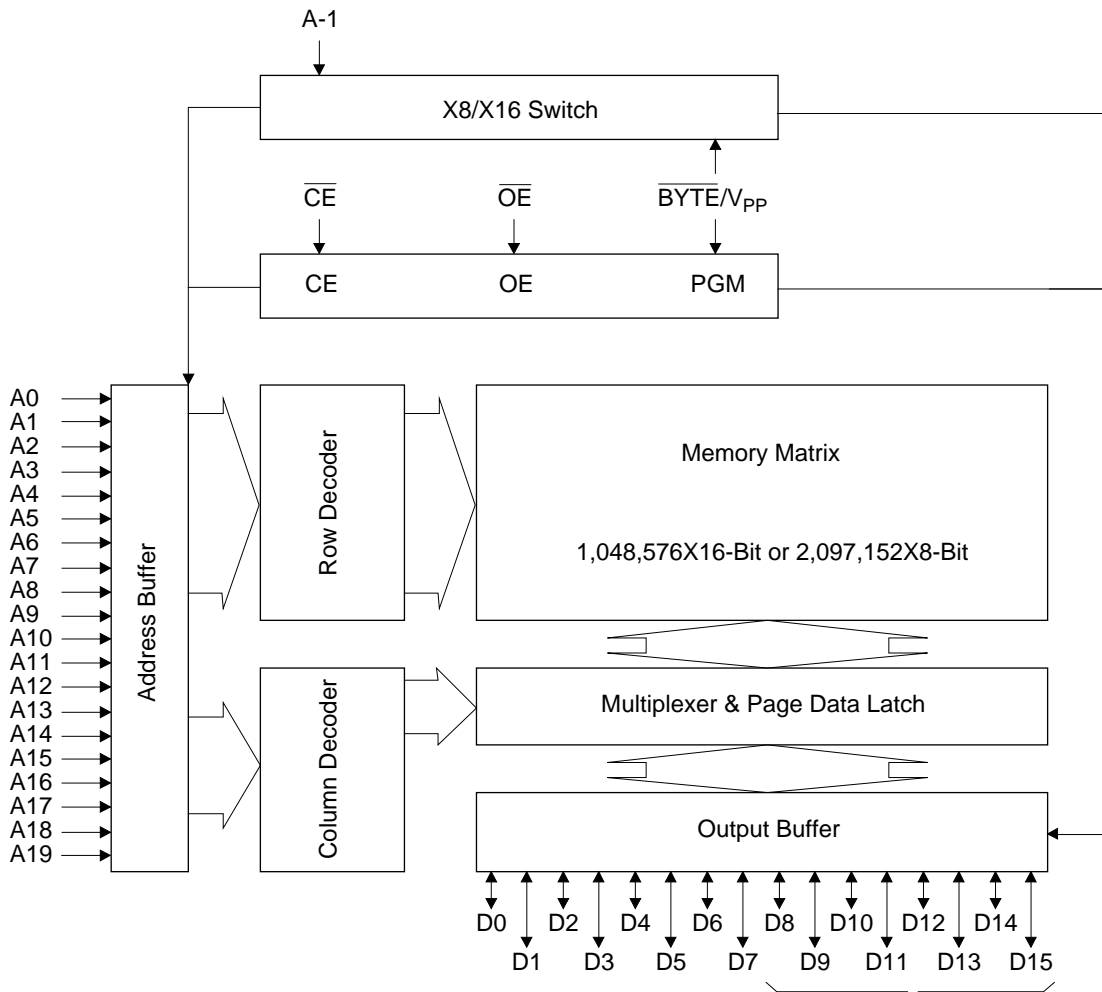

In 8-bit output mode, these pins are three-stated and pin D15 functions as the A-1 address pin.

FUNCTION TABLE

MODE	\overline{CE}	\overline{OE}	BYTE/ V_{PP}	V_{CC}	D0 - D7	D8 - D14	D15/A-1
READ (16-Bit)	L	L	H	3.3V	D_{OUT}		
READ (8-Bit)	L	L	L		D_{OUT}	Hi-Z	L/H
OUTPUT DISABLE	L	H	H		Hi-Z		*
			L		Hi-Z		*
STAND-BY	H	*	H	Hi-Z		*	
			L	Hi-Z		*	
PROGRAM	L	H	9.75V	4.0V	D_{IN}		
PROGRAM INHIBIT	H	H			Hi-Z		
PROGRAM VERIFY	H	L			D_{OUT}		

* : Don't Care

ABSOLUTE MAXIMUM RATINGS

Parameter	Symbol	Condition	Value	Unit
Operating temperature under bias	T_{opr}	-	0 to 70	°C
Storage temperature	T_{stg}	-	-55 to 125	°C
Input voltage	V_I	relative to V_{SS}	-0.5 to $V_{CC} + 0.5$	V
Output voltage	V_O		-0.5 to $V_{CC} + 0.5$	V
Power supply voltage	V_{CC}		-0.5 to 5	V
Program power supply voltage	V_{PP}		-0.5 to 11.5	V
Power dissipation per package	P_D	-	1.0	W

RECOMMENDED OPERATING CONDITIONS FOR READ

(Ta=0 to 70°C)

Parameter	Symbol	Condition	Min.	Typ.	Max.	Unit
V_{CC} power supply voltage	V_{CC}	$V_{CC}=3.0V-3.6V$	3.0	-	3.6	V
V_{PP} power supply voltage	V_{PP}		-0.5	-	$V_{CC}+0.5$	V
Input "H" level	V_{IH}		2.2	-	$V_{CC}+0.5^*$	V
Input "L" level	V_{IL}		-0.5**	-	0.6	V

Voltage is relative to V_{SS} * : $V_{CC}+1.5V$ (Max.) when pulse width of overshoot is less than 10nS.

** : -1.5V (Min.) when pulse width of undershoot is less than 10nS.

ELECTRICAL CHARACTERISTICS (Read operation)

DC Characteristics

($V_{CC}=3.3V\pm 0.3V$, $T_a=0$ to $70^{\circ}C$)

Parameter	Symbol	Condition	Min.	Typ.	Max.	Unit
Input leakage current	I_{LI}	$V_I=0$ to V_{CC}	-	-	10	μA
Output leakage current	I_{LO}	$V_O=0$ to V_{CC}	-	-	10	μA
V_{CC} power supply current (Standby)	I_{CS1}	$\overline{CE}=V_{CC}$	-	-	50	μA
	I_{CS2}	$\overline{CE}=V_{IH}$	-	-	1	mA
V_{CC} power supply current (Read)	I_{CCA}	$\overline{CE}=V_{IL}$, $\overline{OE}=V_{IH}$ $t_c=80ns$	-	-	100	mA
V_{PP} power supply current	I_{PP}	$V_{PP}=V_{CC}$	-	-	10	μA
Input "H" level	V_{IH}	-	2.2	-	$V_{CC}+0.5^*$	V
Input "L" level	V_{IL}	-	-0.5**	-	0.6	V
Output "H" level	V_{OH}	$I_{OH}=-400\mu A$	2.4	-	-	V
Output "L" level	V_{OL}	$I_{OL}=2.1mA$	-	-	0.4	V

Voltage is relative to V_{SS}

* : $V_{CC}+1.5V$ (Max.) when pulse width of overshoot is less than 10nS.

** : -1.5V (Min.) when pulse width of undershoot is less than 10nS.

AC Characteristics

($V_{CC}=3.3V\pm 0.3V$, $T_a=0$ to $70^{\circ}C$)

Parameter	Symbol	Condition	Min.	Max.	Unit
Address access cycle time	T_C	-	80	-	ns
Address access time	T_{ACC}	$\overline{CE}=\overline{OE}=V_{IL}$	-	80	ns
Page access cycle time	T_{PC}	-	30	-	ns
Page access time	T_{PAC}	-	-	30	ns
\overline{CE} access time	T_{CE}	$\overline{OE}=V_{IL}$	-	80	ns
\overline{OE} access time	T_{OE}	$\overline{CE}=V_{IL}$	-	40	ns
Output disable time	T_{CHZ}	$\overline{OE}=V_{IL}$	0	30	ns
	T_{OHZ}	$\overline{CE}=V_{IL}$	0	25	ns
Output hold time	T_{OH}	$\overline{CE}=\overline{OE}=V_{IL}$	0	-	ns

Measurement conditions

Input signal level	-----	0V/3V
Input timing reference level	-----	0.8V/2.0V
Output load	-----	100pF
Output timing reference level	-----	0.8V/2.0V

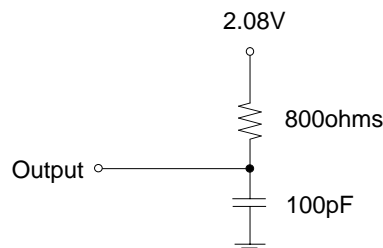

TIMING CHART

NORMAL MODE READ CYCLE

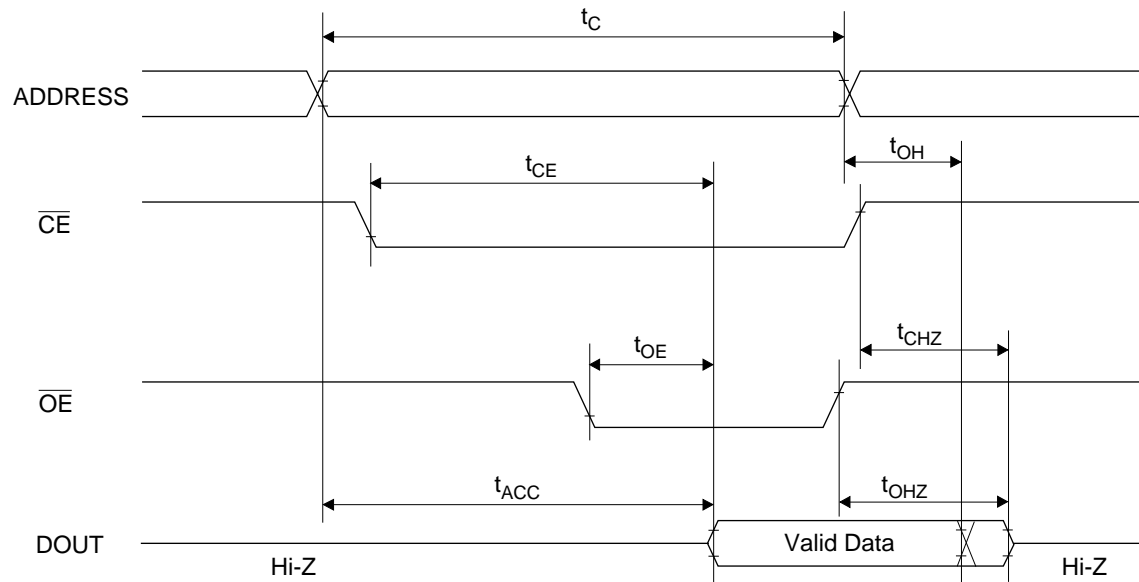

PAGE MODE READ CYCLE

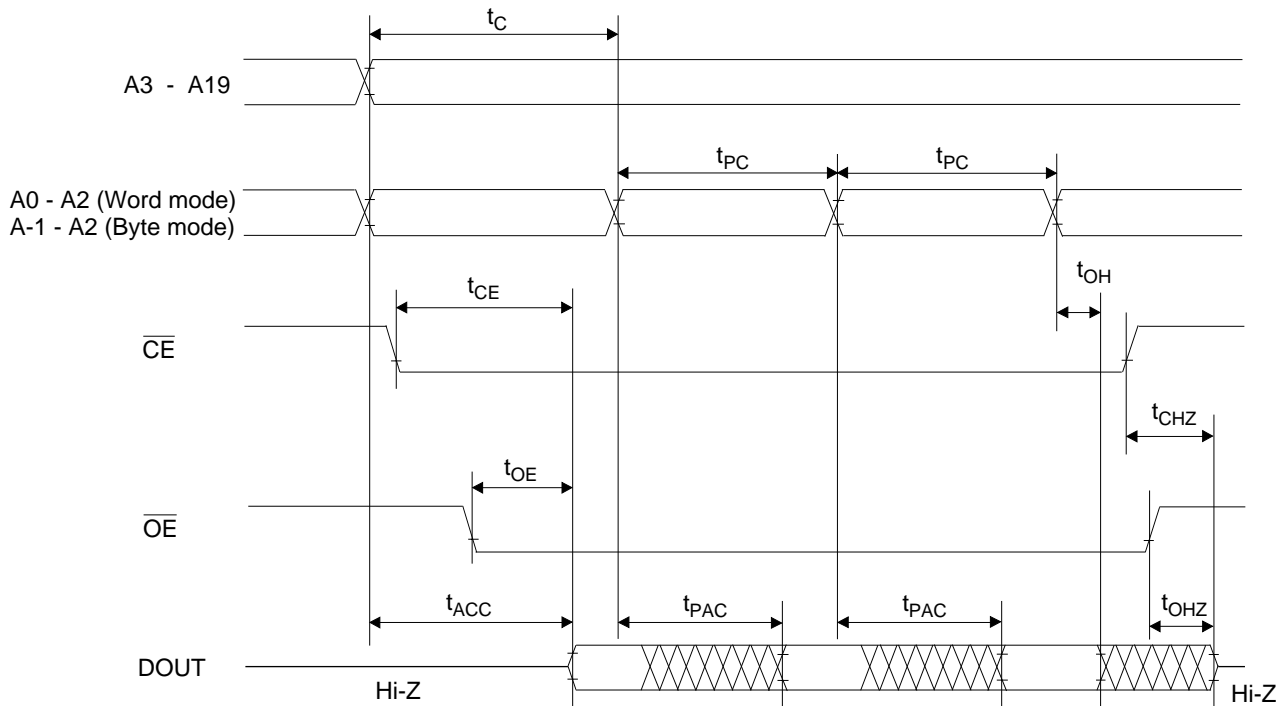

ELECTRICAL CHARACTERISTICS (Programming operation)**DC Characteristics**

(Ta=25°C±5°C)

Parameter	Symbol	Condition	Min.	Typ.	Max.	Unit
Input leakage current	I _{LI}	V _I =V _{CC} +0.5V	-	-	10	μA
V _{PP} power supply current (Program)	I _{PP2}	$\overline{CE}=V_{IL}$	-	-	50	mA
V _{CC} power supply current	I _{CC}	-	-	-	80	mA
Input "H" level	V _{IH}	-	3.0	-	V _{CC} +0.5	V
Input "L" level	V _{IL}	-	-0.5	-	0.8	V
Output "H" level	V _{OH}	I _{OH} =-400μA	2.4	-	-	V
Output "L" level	V _{OL}	I _{OL} =2.1mA	-	-	0.45	V
Program voltage	V _{PP}	-	9.5	9.75	10.0	V
V _{CC} power supply voltage	V _{CC}	-	3.9	4.0	4.1	V

Voltage is relative to V_{SS}**AC Characteristics**(V_{CC}=4.0V±0.1V, V_{pp}=9.75V±0.25V, Ta=25°C±5°C)

Parameter	Symbol	Condition	Min.	Typ.	Max.	Unit
Address set-up time	T _{AS}	-	100	-	-	ns
\overline{OE} set-up time	T _{OES}	-	2	-	-	μs
Data set-up time	T _{DS}	-	100	-	-	ns
Address hold time	T _{AH}	-	2	-	-	μs
Data hold time	T _{DH}	-	100	-	-	ns
Output float delay from \overline{OE}	T _{OHZ}	-	0	-	100	ns
V _{PP} voltage set-up time	T _{VS}	-	2	-	-	μs
Program pulse width	T _{PW}	-	9	10	11	μs
Data valid from \overline{OE}	T _{OE}	-	-	-	100	ns
Address hold from \overline{OE} high	T _{AHO}	-	0	-	-	ns

Pin Check Function

Pin Check Function is to check contact between each device-pin and each socket-lead with EPROM programmer.

Setting up address as the following condition call the preprogrammed codes on device outputs.

(V_{CC}=3.3V±0.3V, $\overline{CE}=\overline{OE}=V_{IL}$, $\overline{BYTE}/V_{pp}=V_{IH}$, Ta=25°C±5°C)

A0	A1	A2	A3	A4	A5	A6	A7	A8	A9	A10	A11	A12	A13	A14	A15	A16	A17	A18	A19	DATA
0	1	0	1	0	1	0	1	0	VH*	0	1	0	1	0	1	0	0	1	1	FF00
1	0	1	0	1	0	1	0	1	VH*	1	0	1	0	1	0	1	1	0	0	00FF
Other conditions																				FFFF

* :VH=8V±0.25V

Consecutive Programming Waveforms

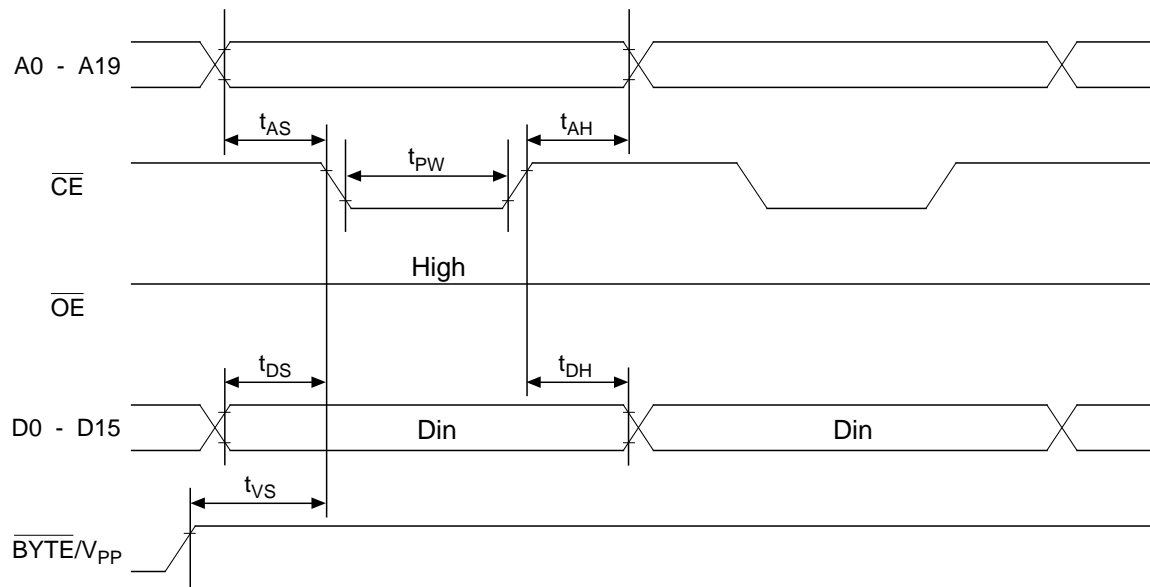

Consecutive Program Verify Waveforms

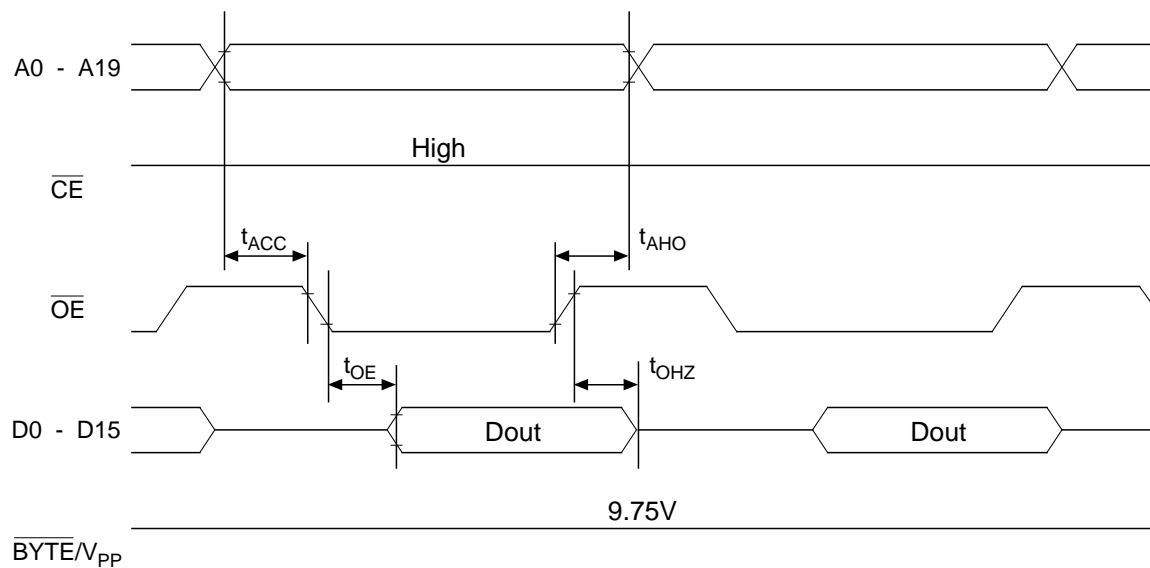

Program and Program Verify Cycle Waveforms

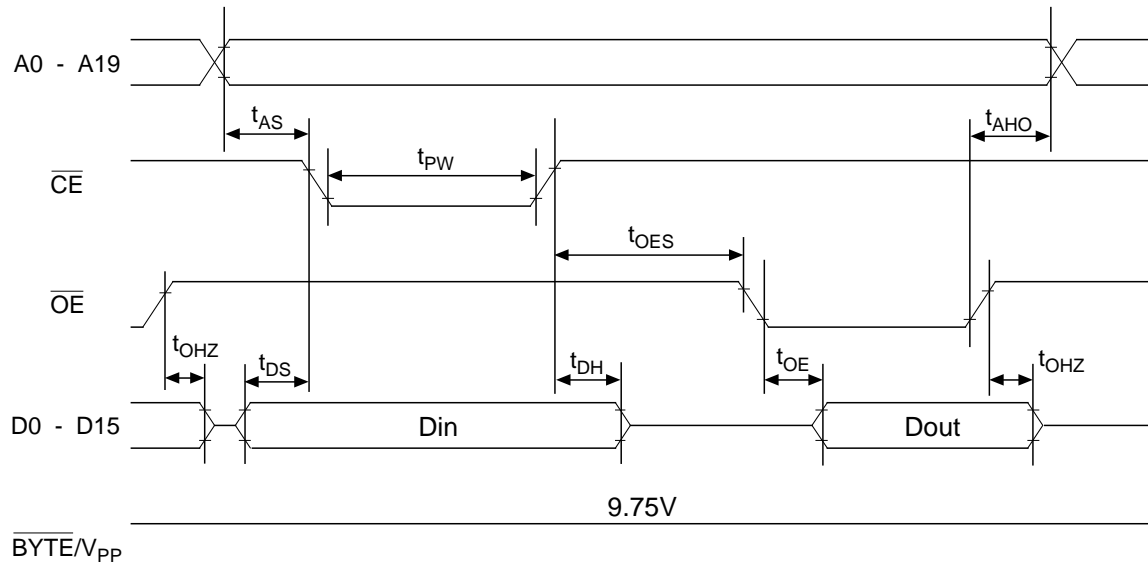

PIN Capacitance

($V_{CC}=3.3V$, $T_a=25^\circ C$, $f=1MHz$)

Parameter	Symbol	Condition	Min.	Typ.	Max.	Unit
Input	C_{IN1}	$V_I=0V$	-	-	8 (10)	pF
\overline{BYTE}/V_{PP}	C_{IN2}		-	-	120	
Output	C_{OUT}	$V_O=0V$	-	-	10 (12)	

(): DIP only

Programming / Verify Flow Chart

Programming

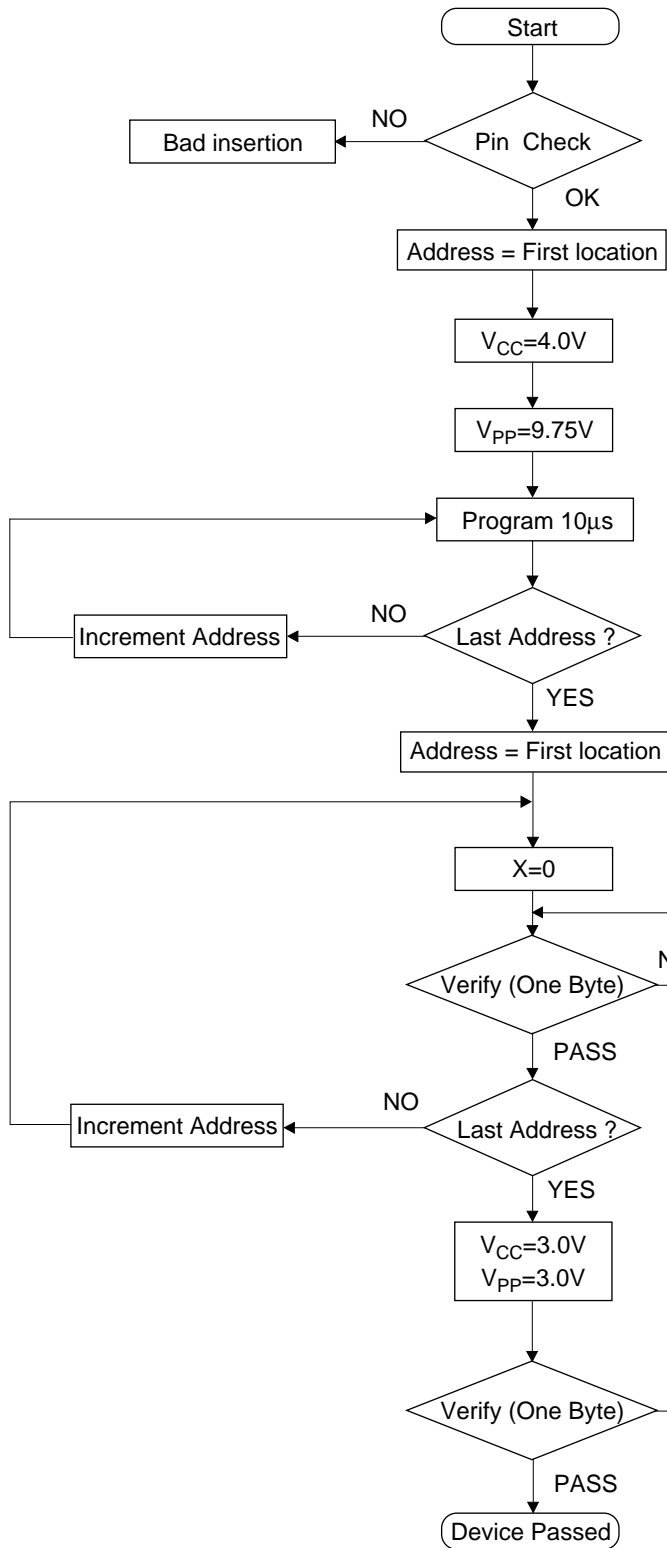

Verify

