

OKI Semiconductor

MS81V04160

REVISION1 1999.4.15

Dual FIFO (262,214-word x 8-Bits) x 2

GENERAL DESCRIPTION

The MS81V04160 is a single-chip 4Mb FIFO functionally composed of two OKI 2Mb FIFO (First-In First-Out) memories which were designed for 256k x 8-bit high-speed asynchronous read/write operation.

The read clocks and the write clocks of each of the 2Mb FIFO memories are connected in common. The MS81V04160, functionally compatible with Oki's 2Mb FIFO memory (MSM51V8222A), can be used as a x16 configuration FIFO.

The MS81V04160 is a field memory for wide or low end use in general commodity TVs and VTRs exclusively and is not designed for high end use in professional graphics systems, which require long term picture storage, data storage, medical use and other storage systems.

The MS81V04160 provides independent control clocks to support asynchronous read and write operations. Different clock rates are also supported, which allow alternate data rates between write and read data streams.

The MS81V04160 provides high speed FIFO (First-in First-out) operation without external refreshing: MS81V04160 refreshes its DRAM storage cells automatically, so that it appears fully static to the users.

Moreover, fully static type memory cells and decoders for serial access enable the refresh free serial access operation, so that serial read and/or write control clock can be halted high or low for any duration as long as the power is on. Internal conflicts of memory access and refreshing operations are prevented by special arbitration logic.

The MS81V04160's function is simple, and similar to a digital delay device whose delay-bit-length is easily set by reset timing. The delay length and the number of read delay clocks between write and read, is determined by externally controlled write and read reset timings.

Additional SRAM serial registers, or line buffers for the initial access of 256 x 16-bit enable high speed first-bit-access with no clock delay just after the write or read reset timings.

Additionally, the MS81V04160 has a write mask function or input enable function (IE), and read- data skipping function or output enable function (OE). The differences between write enable (WE) and input enable (IE), and between read enable (RE) and output enable (OE) are that WE and RE can stop serial write/read address increments, but IE and OE cannot stop the increment, when write/read clocking is continuously applied to MS81V04160. The input enable (IE) function allows the user to write into selected locations of the memory only, leaving the rest of the memory contents unchanged. This facilitates data processing to display a "picture in picture" on a TV screen.

FEATURES

- 512 Rows x 512 columns x 8 bits x2
- Fast FIFO(First-In First-Out)Operation :25ns cycle time
- Self refresh(No refresh control is required)
- High speed asynchronous serial access
Read/Write Cycle Time 25ns/30ns
Access Time 22ns/25ns
- Variable length delay bit (600 to 262215)
- Write mask function (Output enable control)
- Cascading capability by mode setting
- Single power supply:3.3V±10%
- Package:
100-Pin plastic TQFP(TQFP 100-P-1414-0.50-k)(Product:MS81V04160-xxTB)
xx indicates speed rank.

| Parameter | Symbol | MS81V04160-xxTB | |
|--------------------------|----------------------|-----------------|------|
| | | -25 | -30 |
| Access Time | tAC | 23ns | 30ns |
| Read/Write Cycle Time | tSWC tSRC | 25ns | 30ns |
| Operation current | Icc1 | 80mA | 80mA |
| Standby current | Icc2 (MODE2 ="L") | 3mA | 3mA |

PIN CONFIGURATION (TOP VIEW)

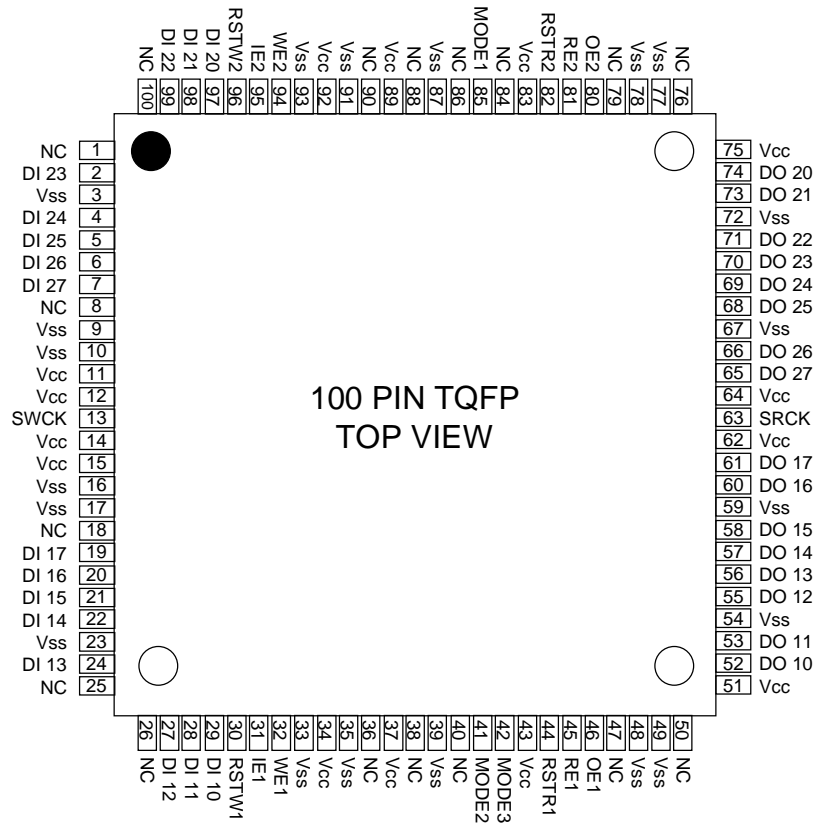

| Pin Name | Function | Pin Name | Function |
|-----------|---------------------|----------|---------------------|
| SWCK | Serial Write Clock | SRCK | Serial Read Clock |
| WE1 | Port1 Write Inable | WE2 | Port2 Write Inable |
| RE1 | Port1 Read Inable | RE2 | Port2 Read Inable |
| IE1 | Port1 Input Inable | IE2 | Port2 Input Inable |
| OE1 | Port1 Output Inable | OE2 | Port2 Output Inable |
| RSTW1 | Port1 Reset Write | RSTW2 | Port2 Reset Write |
| RSTR1 | Port1 Reset Read | RSTR2 | Port2 Reset Read |
| DI 10-17 | Port1 Data Input | DI 20-27 | Port2 Data Input |
| DO 10-17 | Port1 Data Output | DO 20-27 | Port2 Data Output |
| MODE1,2,3 | Mode Input | NC | No Connection |
| Vcc | Power Supply(3.3V) | Vss | Ground(0V) |

Note: The same power supply voltage must be provided to every Vcc pin, and the same GND voltage level must be provided to every Vss pin.

BLOCK DIAGRAM

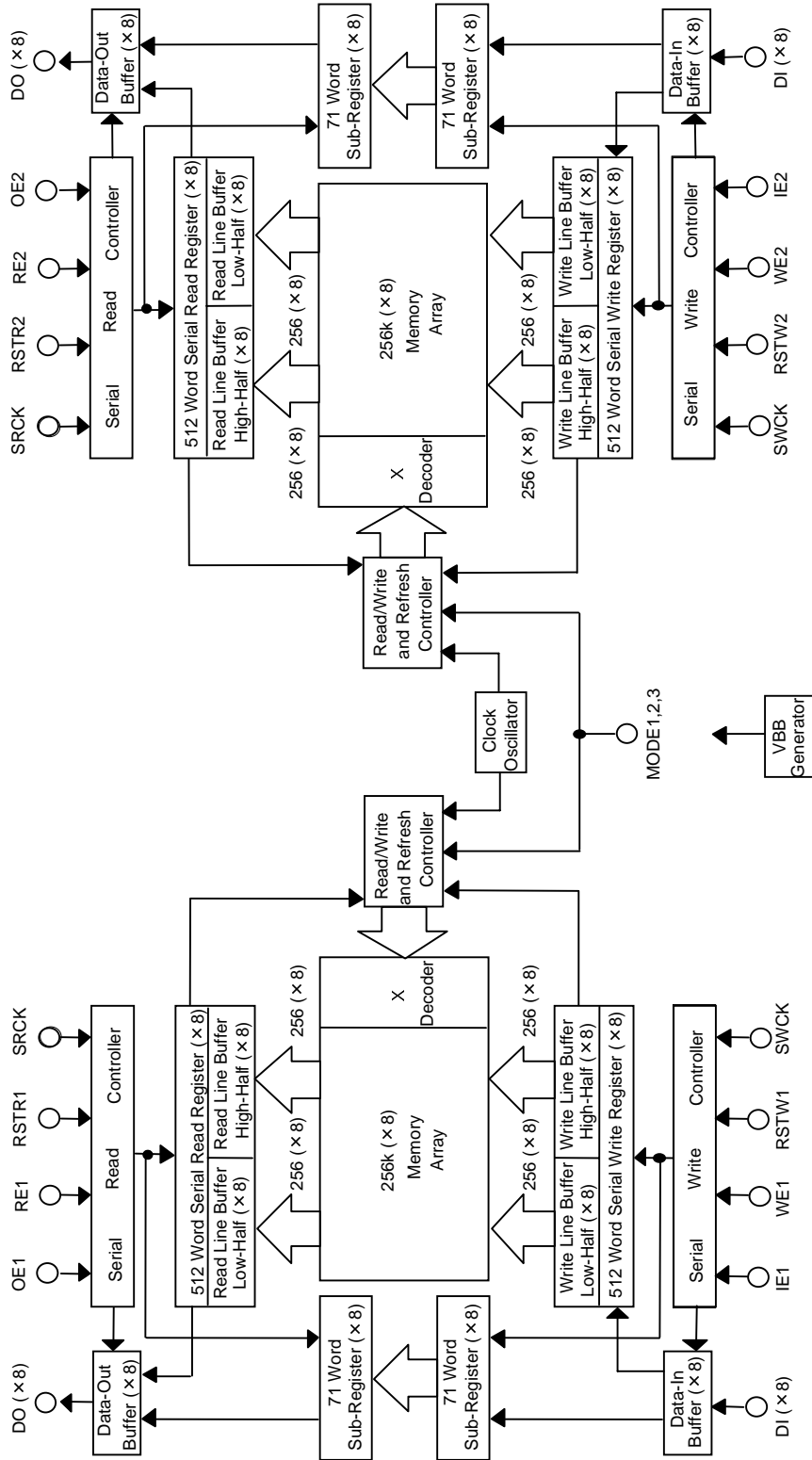

PIN DESCRIPTION

Data Inputs: (DIN 10 - 17)

These pins are used for serial data inputs.

Write Reset: RSTW1

The first positive transition of SWCK after RSTW becomes high resets the write address pointers to zero. RSTW1 setup and hold times are referenced to the rising edge of SWCK. Because the write reset function is solely controlled by the SWCK rising edge after the high level of RSTW, the states of WE1 and IE1 are ignored in the write reset cycle. Before RSTW1 may be brought high again for a further reset operation, it must be low for at least two SWCK cycles.

Write Enable: WE1

WE1 is used for data write enable/disable control. WE1 high level enables the input, and WE1 low level disables the input and holds the internal write address pointer. There are no WE1 disable time (low) and WE1 enable time (high) restrictions, because the MS8104160 is in fully static operation as long as the power is on. Note that WE1 setup and hold times are referenced to the rising edge of SWCK.

Input Enable: IE1

IE1 is used to enable/disable writing into memory. IE1 high level enables writing. The internal write address pointer is always incremented by cycling SWCK regardless of the IE1 level. Note that IE1 setup and hold times are referenced to the rising edge of SWCK.

Data Out: (DOUT 0 - 11)

These pins are used for serial data outputs.

Read Reset: RSTR1

The first positive transition of SRCK after RSTR1 becomes high resets the read address pointers to zero. RSTR1 setup and hold times are referenced to the rising edge of SRCK. Because the read reset function is solely controlled by the SRCK rising edge after the high level of RSTR, the states of RE1 and OE1 are ignored in the read reset cycle. Before RSTR may be brought high again for a further reset operation, it must be low for at least two SRCK cycles.

Read Enable: RE1

The function of RE1 is to gate of the SRCK clock for incrementing the read pointer. When RE1 is high before the rising edge of SRCK, the read pointer is incremented. When RE1 is low, the read pointer is not incremented. RE1 setup times (tRENS and tRDSS) and RE1 hold times (tRENH and tRDSH) are referenced to the rising edge of the SRCK clock.

Output Enable: OE1

OE1 is used to enable/disable the outputs. OE1 high level enables the outputs. The internal read address pointer is always incremented by cycling SRCK regardless of the OE1 level. Note that OE1 setup and hold times are referenced to the rising edge of SRCK.

Serial Write Clock: SWCK

The SWCK latches the input data on chip when WE1, 2 is high, and also increments the internal write address pointer. Data-in setup time t_{DS} , and hold time t_{DH} are referenced to the rising edge of SWCK.

Serial Read Clock: SRCK

Data is shifted out of the data registers. It is triggered by the rising edge of SRCK when RE1, 2 is high during a read operation. The SRCK input increments the internal read address pointer when RE1,2 is high.

The three-state output buffer provides direct TTL compatibility (no pullup resistor required). Data out is the same polarity as data in. The output becomes valid after the access time interval t_{AC} that begins with the rising edge of SRCK. *There are no output valid time restriction on MS8104160.

Data Input: (DIN 20-27)

These pins are used for serial data inputs.

Write Reset: RSTW2

The first positive transition of SWCK after RSTW becomes high resets the write address pointers to zero. RSTW2 setup and hold times are referenced to the rising edge of SWCK. Because the write reset function is solely controlled by the SWCK rising edge after the high level of RSTW2, the states of WE2 and IE2 are ignored in the write reset cycle. Before RSTW2 may be brought high again for a further reset operation, it must be low for at least two SWCK cycles.

Write Enable: WE2

WE is used for data write enable/disable control. WE2 high level enables the input, and WE2 low level disables the input and holds the internal write address pointer. There are no WE2 disable time (low) and WE2 enable time (high) restrictions, because the MS8104160 is in fully static operation as long as the power is on. Note that WE2 setup and hold times are referenced to the rising edge of SWCK.

Input Enable: IE2

IE2 is used to enable/disable writing into memory. IE2 high level enables writing. The internal write address pointer is always incremented by cycling SWCK regardless of the IE2 level. Note that IE2 setup and hold times are referenced to the rising edge of SWCK.

Data Out : (DOUT 20 – 27)

These pins are used for serial data outputs.

Read Reset: RSTR2

The first positive transition of SRCK after RSTR2 becomes high resets the read address pointers to zero. RSTR2 setup and hold times are referenced to the rising edge of SRCK. Because the read reset function is solely controlled by the SRCK rising edge after the high level of RSTR2, the states of RE2 and OE2 are ignored in the read reset cycle. Before RSTR2 may be brought high again for a further reset operation, it must be low for at least *two SRCK cycles.

Output Enable: OE2

OE2 is used to enable/disable the outputs. OE2 high level enables the outputs. The internal read address pointer is always incremented by cycling SRCK regardless of the OE2 level. Note that OE2 setup and hold times are referenced to the rising edge of SRCK.

Mode Setting: MODE1

The Cascade/Non cascade select pin. Setting the MODE1 pin to the Vcc level configures this memory device as cascade type and setting the pin to the Vss level configures this memory device as non cascade. During memory operation, the pin must be permanently connected to Vcc or Vss. If a MODE1 level is changed during memory operation, memory data is not guaranteed.

Note: Cascade/Non cascade

When MODE1 is set to the Vss level, memory accessing starts in the cycle in which the control signals are input (Non cascade type).

When MODE1 is set to the Vcc level, memory accessing starts in the cycle subsequent to the cycle in which the control signals are input (Cascade type). This type is used for consecutive memory accessing.

MODE2 Setting: MODE2

MODE2 selects whether the control input signals are enabled at a high level or a low level. Setting MODE2 to the Vcc level enables the control input signals at a low level and setting MODE2 to the Vss level enables the control input signals at a high level.

MODE Setting: MODE3

The boost control pin for data-out Buffer. For the MS8104160, the MODE3 pin should be permanently Connected to the Vss level.

ELECTRICAL CHARACTERISTICS**Absolute Maximum Ratings**

| Parameter | Symbol | Condition | Rating | Unit |
|-----------------------|-----------|-----------------------------------------|-------------|-------------------|
| Input Output Voltage | V_T | at $T_a = 25^\circ \text{C}$, V_{SS} | -1.0 to 4.6 | V |
| Output Current | I_{OS} | $T_a = 25^\circ \text{C}$ | 50 | mA |
| Power Dissipation | P_D | $T_a = 25^\circ \text{C}$ | 1 | W |
| Operating Temperature | T_{opr} | — | 0 to 70 | $^\circ \text{C}$ |
| Storage Temperature | T_{stg} | — | -55 to 150 | $^\circ \text{C}$ |

Recommended Operating Conditions

| Parameter | Symbol | Min. | Typ. | Max. | Unit |
|----------------------|----------|------|----------|----------------|------|
| Power Supply Voltage | V_{CC} | 3.0 | 3.3 | 3.6 | V |
| Power Supply Voltage | V_{SS} | 0 | 0 | 0 | V |
| Input High Voltage | V_{IH} | 2.4 | V_{CC} | $V_{CC} + 0.3$ | V |
| Input Low Voltage | V_{IL} | -0.3 | 0 | 0.8 | V |

DC Characteristics

| Parameter | Symbol | Condition | Min. | Max. | Unit | |
|--------------------------|------------|--------------------------------------------------|-----------|------|---------------|----|
| Input LeadKage Current | I_{LI} | $0 < V_I < V_{CC}$, Other Pins Tested at $V=0V$ | -10 | 10 | μA | |
| Output LeadKage Current | I_{LO} | $0 < V_O < V_{CC}$ | -10 | 10 | μA | |
| Output "H" Level Voltage | V_{OH} | $I_{OH} = -1 \text{ mA}$ | 2.4 | - | V | |
| Output "L" Level Voltage | V_{OL} | $I_{OL} = 2 \text{ mA}$ | - | 0.4 | V | |
| Operating Current | I_{CC1} | Minimum Cycle Time, Output Open | - | 80 | mA | |
| Standby Current | I_{CC2A} | Input Pin = V_{IH} / V_{IL} | MODE2="L" | - | 3 | mA |
| | I_{CC2B} | | MODE2="H" | - | 10 | |

Capacitance

(Ta = 25° C , f = 1 MHz)

| Parameter | Symbol | Max. | Unit |
|-----------------------------------------------------------------|--------|------|------|
| Input Capacitance (DIN, SWCK, SRCK, RSTW, RSTR, WE, RE, IE, OE) | C_I | 7 | pF |
| Output Capacitance (DOUT) | C_O | 7 | pF |

AC Characteristics(V_{CC} = 3.0 - 3.6V, T_a = 0 to 70° C)

| Parameter | Symbol | MS81V04160-25 | | MS81V04160-30 | | Unit |
|---------------------------------|--------------------|---------------|------|---------------|------|------|
| | | Min. | Max. | Min. | Max. | |
| Access Time from SRCK | t _{AC} | - | 23 | - | 30 | ns |
| DOUT Hold Time from SRCK | t _{DDCK} | 6 | - | 6 | - | ns |
| DOUT Enable Time from SRCK | t _{DECK} | 6 | 23 | 6 | 30 | ns |
| SWCK "H" Pulse Width | t _{WSWH} | 15 | - | 20 | - | ns |
| SWCK "L" Pulse Width | t _{WSWL} | 15 | - | 20 | - | ns |
| Input Time Data Setup | t _{DS} | 3 | - | 5 | - | ns |
| Input Data Hold Time | t _{DH} | 5 | - | 5 | - | ns |
| WE Enable Setup Time | t _{WENS} | 5 (7) | - | 5 (7) | - | ns |
| WE Enable Hold Time | t _{WENH} | 5 | - | 5 | - | ns |
| WE Disable Setup Time | t _{WDSS} | 5 | - | 5 | - | ns |
| WE Disable Hold Time | t _{WDSH} | 5 | - | 5 | - | ns |
| IE Enable Setup Time | t _{IENS} | 5 (7) | - | 5 (7) | - | ns |
| IE Enable Hold Time | t _{IENH} | 5 | - | 5 | - | ns |
| IE Disable Setup Time | t _{IDSS} | 5 | - | 5 | - | ns |
| IE Disable Hold Time | t _{IDSH} | 5 | - | 5 | - | ns |
| WE "H" Pulse Width | t _{WWEH} | 5 | - | 10 | - | ns |
| WE "L" Pulse Width | t _{WWEL} | 5 | - | 10 | - | ns |
| IE "H" Pulse Width | t _{WIEH} | 5 | - | 10 | - | ns |
| IE "L" Pulse Width | t _{WIEL} | 5 | - | 10 | - | ns |
| RSTW Setup Time | t _{RSTWS} | 3 | - | 3 | - | ns |
| RSTW Hold Time | t _{RSTWH} | 10 | - | 10 | - | ns |
| SRCK "H" Pulse Width | t _{WSRH} | 15 | - | 20 | - | ns |
| SRCK "L" Pulse Width | t _{WSRL} | 15 | - | 20 | - | ns |
| RE Enable Setup Time | t _{RENS} | 3 | - | 3 | - | ns |
| RE Enable Hold Time | t _{RENH} | 5 | - | 5 | - | ns |
| RE Disable Setup Time | t _{RDSS} | 3 | - | 3 | - | ns |
| RE Disable Hold Time | t _{RDSH} | 5 | - | 5 | - | ns |
| OE Enable Setup Time | t _{OENS} | 3 | - | 3 | - | ns |
| OE Enable Hold Time | t _{OENH} | 5 | - | 5 | - | ns |
| OE Disable Setup Time | t _{ODSS} | 3 | - | 3 | - | ns |
| OE Disable Hold Time | t _{ODSH} | 5 | - | 5 | - | ns |
| RE "H" Pulse Width | t _{WREH} | 5 | - | 10 | - | ns |
| RE "L" Pulse Width | t _{WREL} | 5 | - | 10 | - | ns |
| OE "H" Pulse Width | t _{WOEH} | 5 | - | 10 | - | ns |
| OE "L" Pulse Width | t _{WOEL} | 5 | - | 10 | - | ns |
| RSTR Setup Time | t _{RSTRS} | 3 | - | 3 | - | ns |
| RSTR Hold Time | t _{RSTRH} | 10 | - | 10 | - | ns |
| SWCK Cycle Time | t _{SWC} | 25 | - | 30 | - | ns |
| SRCK Cycle Time | t _{SRC} | 25 | - | 30 | - | ns |
| Transition Time (Rise and Fall) | t _T | 3 | 30 | 3 | 30 | ns |

- Notes:
1. Input signal reference levels for the parameter measurement are $V_{IH} = 3.0\text{ V}$ and $V_{IL} = 0\text{ V}$. The transition time t_T is defined to be a transition time that signal transfers between $V_{IH} = 3.0\text{ V}$ and $V_{IL} = 0\text{ V}$.
 2. AC measurements assume $t_T = 3\text{ ns}$.
 3. Read address must have more than a 600 address delay than write address in every cycle when asynchronous read/write is performed.
 4. Read must have more than a 600 address delay than write in order to read the data written in a current series of write cycles which has been started at last write reset cycle: this is called "new data read". When read has less than a 70 address delay than write, the read data are the data written in a previous series of write cycles which had been written before at last write reset cycle: this is called "old data read".
 5. When the read address delay is between more than 71 and less than 599 or more than 262,214, read data will be undetermined. However, normal write is achieved in this address condition.
 6. Outputs are measured with a load equivalent to 1 TTL load and 30 pF. Output reference levels are $V_{OH} = 1.5\text{ V}$ and $V_{OL} = 1.5\text{ V}$.
 7. (): $\text{MODE2} = V_{CC}$

OPERATION MODE

Write Operation Cycle (MODE2=Vss)

The write operation is controlled by seven control signals, SWCK, RSTW1, RSTW2, WE1, WE2 and IE1, IE2. Port1 write operation is accomplished by cycling SWCK, and holding WE1 high after the write address pointer reset operation or RSTW1. RSTW1 must be preformed for internal circuit initialization before Write operation.

Each write operation, which begins after RSTW1, must contain at least 80 active write cycles, i.e. SWCK cycles while WE1 and IE1 are high. To transfer the last data to the DRAM array, which at that time is stored in the serial data registers attached to the DRAM array, an RSTW1 operation is required after the last SWCK cycle.

Note that every write timing of MS8104160 is delayed by one clock compared with read timings for easy cascading without any interface delay devices.

Setting MODE1 to the Vss level starts write data accessing in the cycle in which RSTW1, WE1, and IE1 control signals are input.

Setting MODE1 to the Vcc level starts write data accessing in the cycle subsequent to the cycle in which RSTW1, WE1, and IE1 control signals are input.

These operation are the same for Port1 and Port2.

Settings of WE1, 2 and IE1, 2 to the operation mode of Write address pointer and Data input.

| WE1,2 | IE1,2 | Internal Write address pointer | Data input |
|-------|-------|--------------------------------|------------|
| H | H | Incremented | Input |
| H | L | | Not input |
| L | X | Halted | |

X indicates "don't care"

Write Operation Cycle (MODE2=Vcc)

The write Operation is controlled by seven control signals, SWCK, RSTW1, RSTW2, WE1, WE2, and IE1, IE2. Port1 write operation is accomplished by cycling SWCK and holding both WE1 and IE1 low after the write address pointer reset operation or RSTW1. RSTW1 must be performed for internal circuit initialization before write operation.

Each write operation, which begins after RSTW1, must contain at least 80 active write cycle, i.e. SWCK cycles while WE1 and IE1 are high. To transfer the last data to the DRAM array, which at that time is stored in the serial data registers attached to the DRAM array, an RSTW1 operation is required after the last SWCK cycle.

Note that every write timing of MS8104160 is delayed by one clock compared with read timings for easy cascading without any interface delay devices.

Setting MODE1 to the Vss level starts write data accessing in the cycle in which RSTW1, WE1, and IE1 control signals are input.

Setting MODE1 to the Vcc level starts write data accessing in the cycle in which RSTW1, WE1, and IE1 control signals are input.

Setting MODE1 to the Vcc level starts write data accessing in the cycle subsequent to the cycle in which RSTW1, WE1, and IE1 control signals are input.

These operations are the same for port1 and Port2.

Settings of WE1, 2 and IE1, 2 to the operation mode of Write address pointer and Data input.

| WE1,2 | IE1,2 | Internal Write address pointer | Data input |
|-------|-------|--------------------------------|------------|
| L | L | Incremented | Input |
| L | H | | Not input |
| H | X | Halted | |

X indicates "don't care"

Read Operation Cycle (MODE2=Vss)

The read operation is controlled by seven control signals, SRCK, RSTR1, RSTR2, RE1, RE2, and OE1, OE2. Port1 read operation is accomplished by cycling SRCK, and holding both RE1 and OE1 high after the read address pointer reset operation or RSTR1.

Each read operation, which begins after RSTR1, must contain at least 80 active read cycles, i.e. SRCK cycles while RE1 and OE1 are high.

These operations are the same for Port1 and Port2.

Settings of RE1, 2 and OE1, 2 to the operation mode of read address pointer and Data output.

| RE1,2 | OE1,2 | Internal Write address pointer | Data output |
|-------|-------|--------------------------------|----------------|
| H | H | Incremented | Output |
| H | L | | High impedance |
| L | H | Halted | Output |
| L | L | | High impedance |

Read Operation Cycle (MODE2=Vcc)

The read operation is controlled by seven control signals, SRCK, RSTR1, RSTR2, RE1, RE2, and OE1, OE2. Port1 read operation is accomplished by cycling SRCK, and holding both RE1 and OE1 high after the read address pointer reset operation or RSTR1.

Each read operation, which begins after RSTR1, must contain at least 80 active read cycles, i.e. SRCK cycles while RE1 and OE1 are low.

These operations are the same for Port1 and Port2.

Settings of RE1, 2 and OE1, 2 to the operation mode of read address pointer and Data output.

| RE1,2 | OE1,2 | Internal Write address pointer | Data output |
|-------|-------|--------------------------------|----------------|
| L | L | Incremented | Output |
| L | H | | High impedance |
| H | L | Halted | Output |
| H | H | | High impedance |

Power-up and Initialization

On power-up, the device is designed to begin proper operation after at least 100 us after Vcc has stabilized to a value within the range of recommended operating conditions. After this 100 us stabilization interval, the following initialization sequence must be performed. Because the read and write address pointers are undefined after power-up, a minimum of 80 dummy write operations (SWCK cycles) and read operations (SRCK cycles) must be performed, followed by an RSTW1, 2 operation and an RSTR1, 2 operation, to properly initialize the write and the read address pointer. Dummy write cycles/RSTW1, 2 and dummy read cycles/RSTR1, 2 may occur simultaneously.

If these dummy read and write operations start while Vcc and/or the substrate voltage has not stabilized, it is necessary to perform an RSTR1, 2 operation plus a minimum of 80 SRCK cycles plus another RSTR1,2 operation, and an RSTW1,2 operation plus a minimum of 80 SWCK cycles plus another RSTW1,2 operation to properly initialize read and write address pointers.

Old/New Data Access

There must be a minimum delay of 600 SWCK cycles between writing into memory and reading out from memory. If reading from the first field starts with an RSTR1, 2 operation, before the start of writing the second field (before the next RSTW1, 2 operation), then the data just written will be read out.

The start of reading out the first field of data may be delayed past the beginning of writing in the second field of data for as many as 70 SWCK cycles. If the RSTR1, 2 operation for the first field read-out occurs less than 70 SWCK cycles after the RSTW1, 2 operation for the second field write-in, then the internal buffering of the device assures that the first field will still be read out. The first field of data that is read out while the second field of data is written is called "old data". In order to read out "new data", i.e., the second field written in, the delay between an RSTW1, 2 operation and an RSTR1, 2 operation must be at least 600 SRCK cycles. If the delay between RSTW1, 2 and RSTR1, 2 operations is more than 71 but less than 600 cycles, then the data read out will be undetermined. It may be "old data" or "new" data, or a combination of old and new data. Such a timing should be avoided.

TIMING WAVEFORM

Write Cycle Timing (Write Reset) : MODE1=Vcc , MODE2=Vss

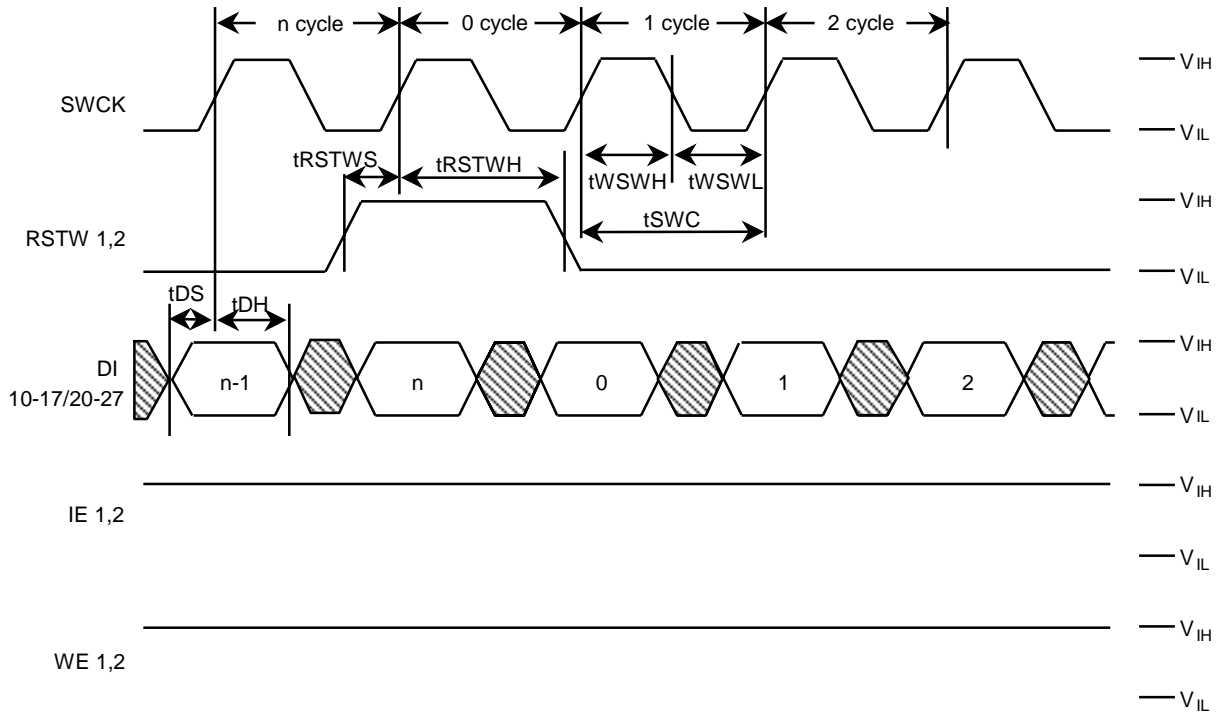

Write Cycle Timing (Write Enable) : MODE1=Vcc , MODE2=Vss

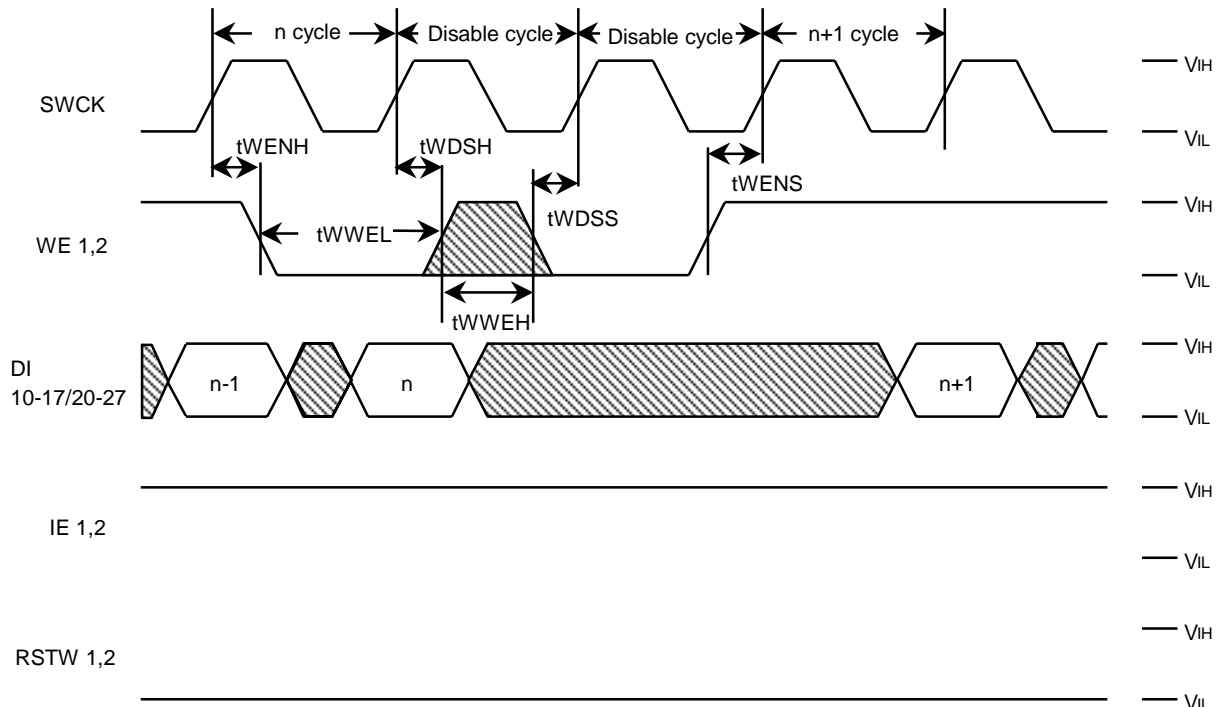

Write Cycle Timing (Input Enable) : MODE1=Vcc , MODE2=Vss

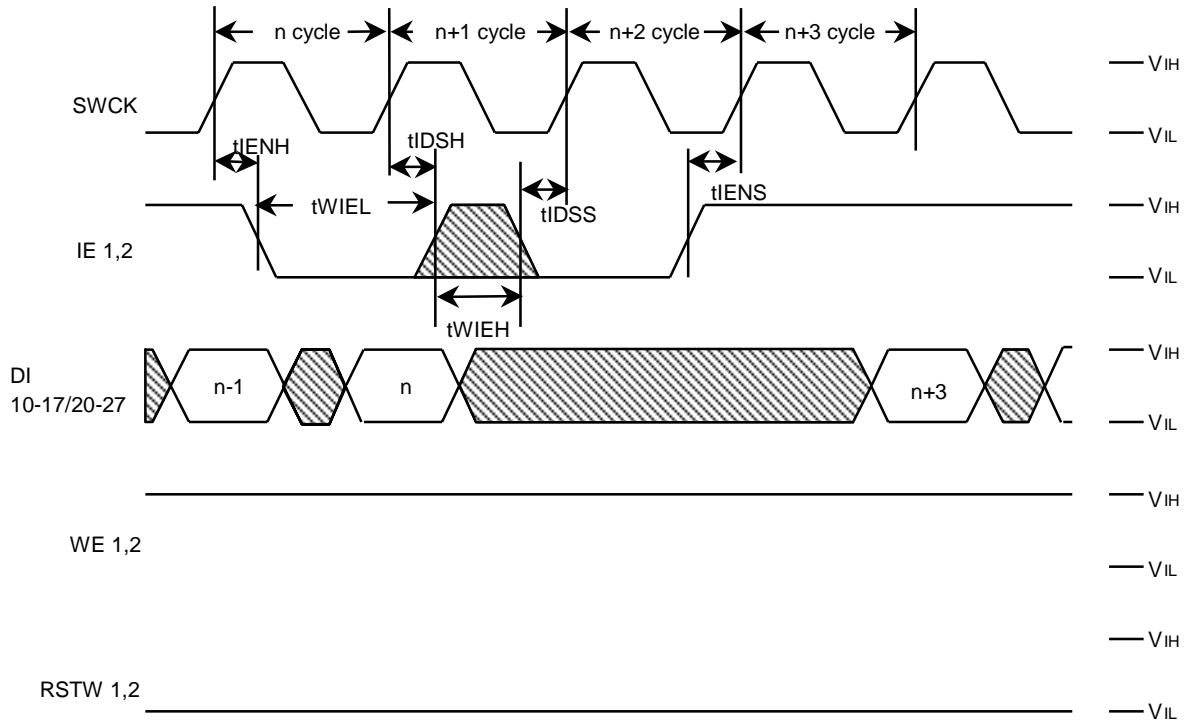

Write Cycle Timing (Write Reset) : MODE1=Vcc , MODE2=Vcc

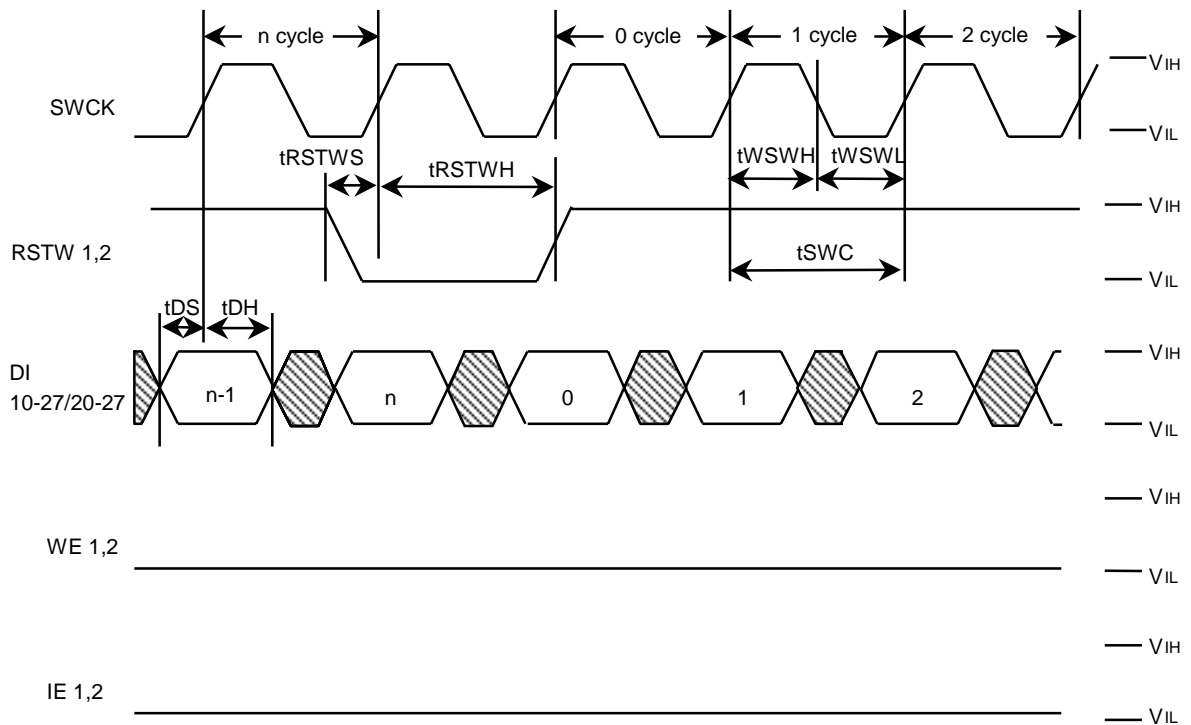

Write Cycle Timing (Write Enable) : MODE1=Vcc , MODE2=Vcc

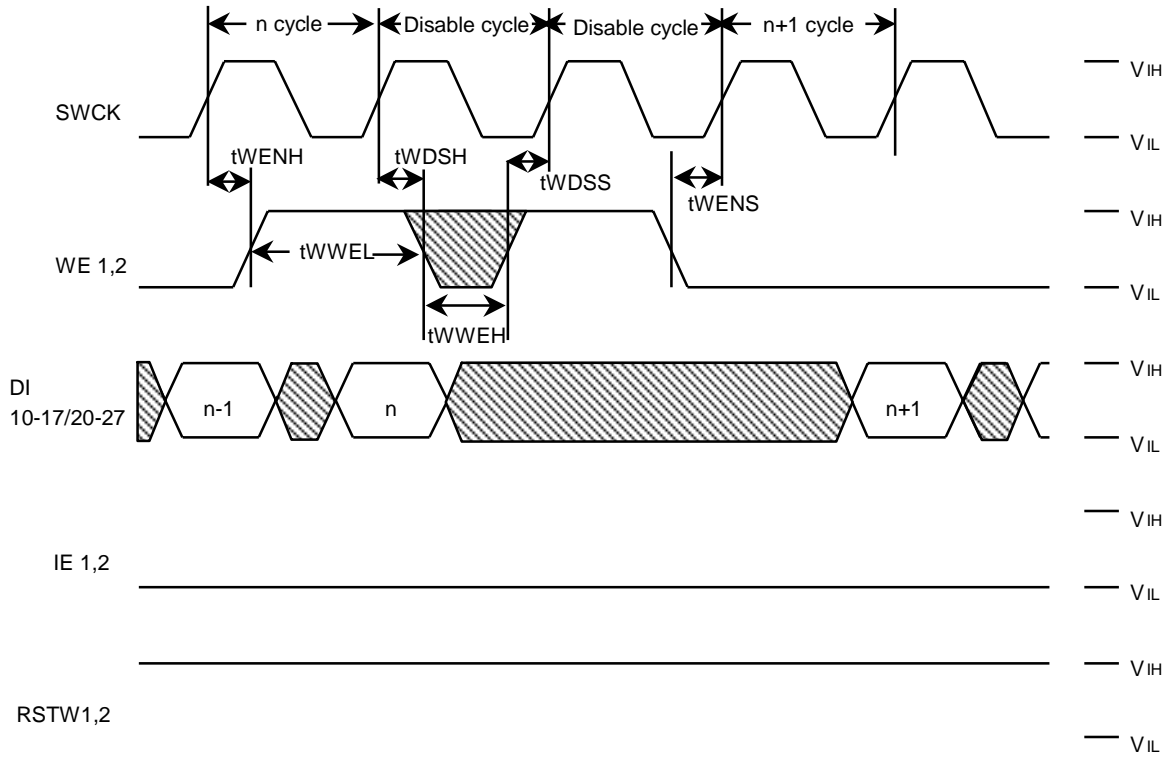

Write Cycle Timing (Input Enable) : MODE1=Vcc , MODE2=Vcc

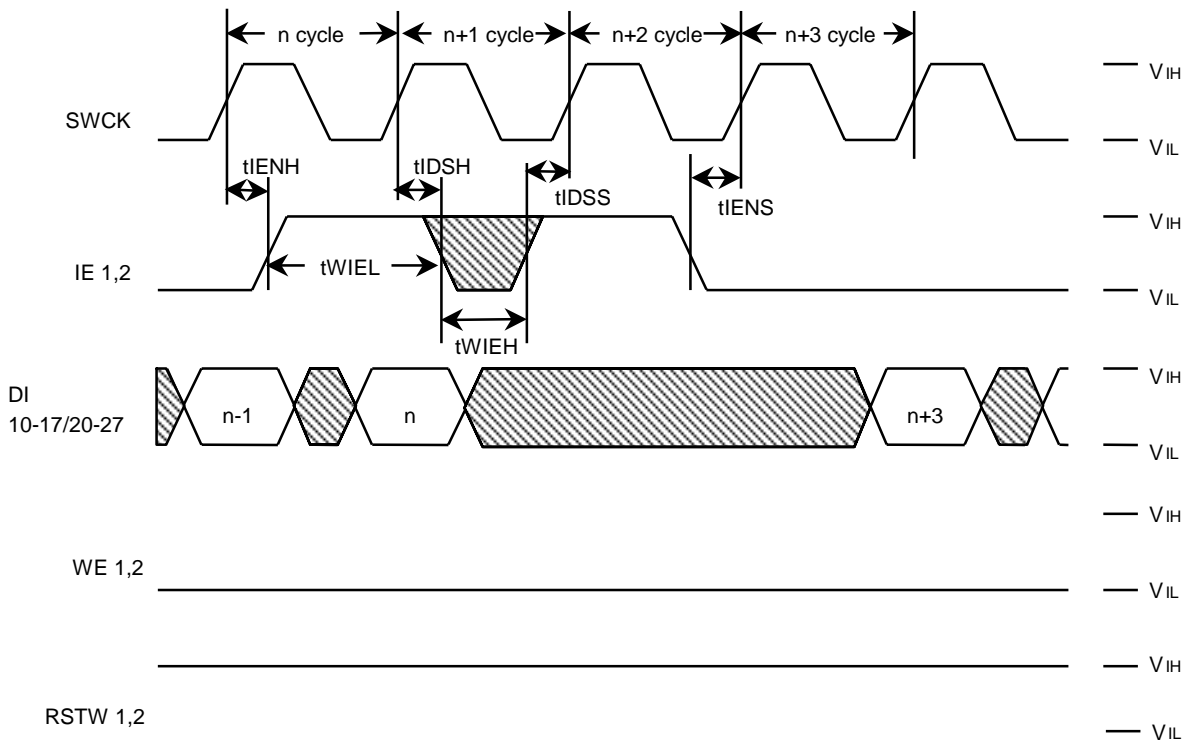

Write Cycle Timing (Write Reset) : MODE1=Vss , MODE2=Vss

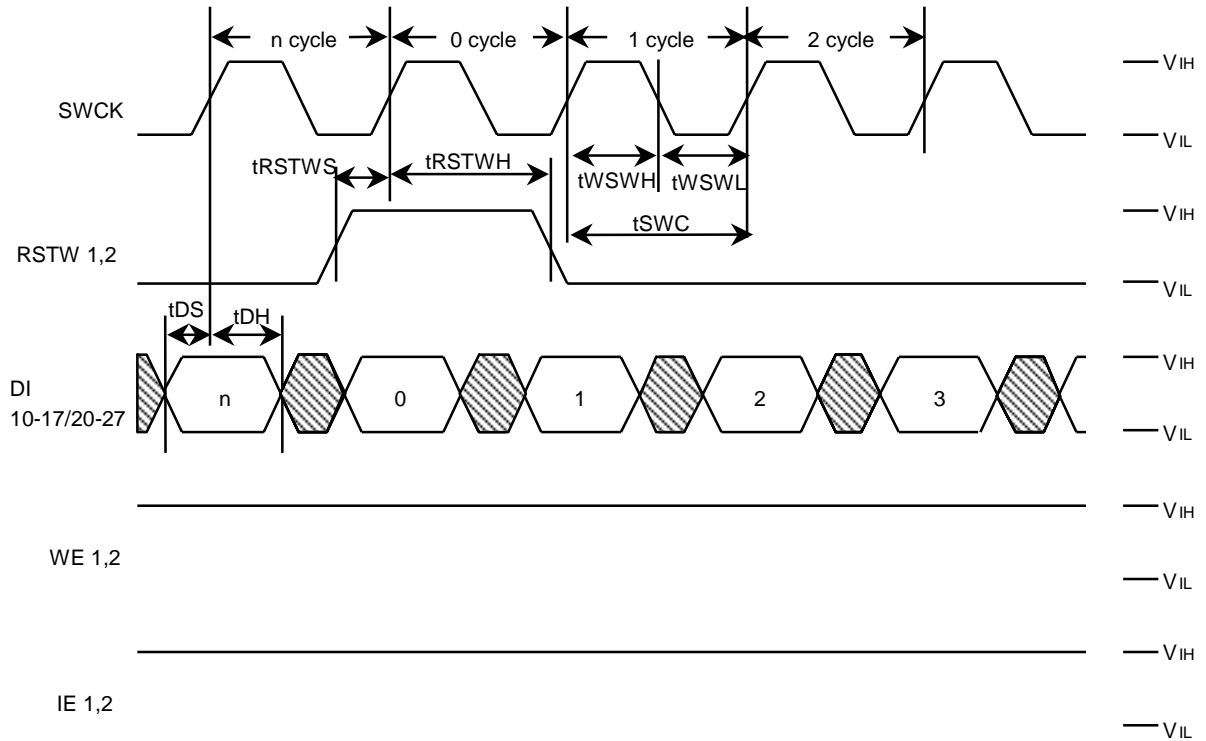

Write Cycle Timing (Write Enable) : MODE1=Vss , MODE2=Vss

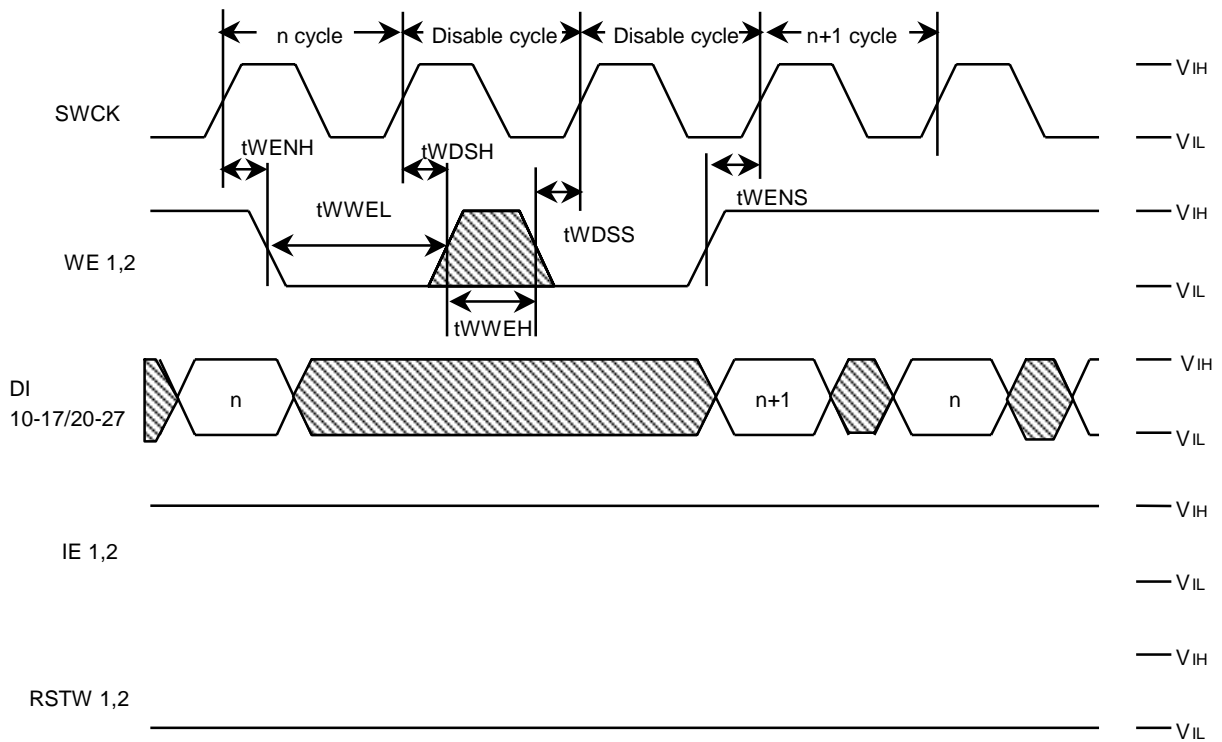

Write Cycle Timing (Input Enable) : MODE1=Vss , MODE2=Vss

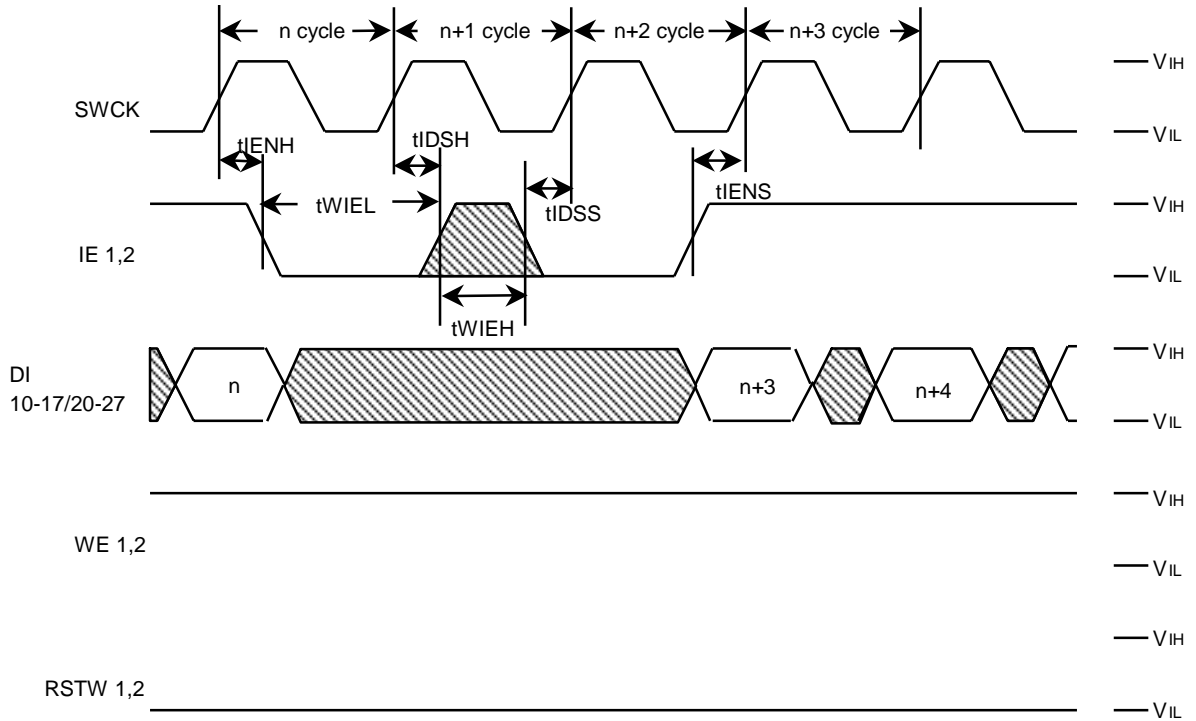

Write Cycle Timing (Write Reset) : MODE1=Vss , MODE2=Vcc

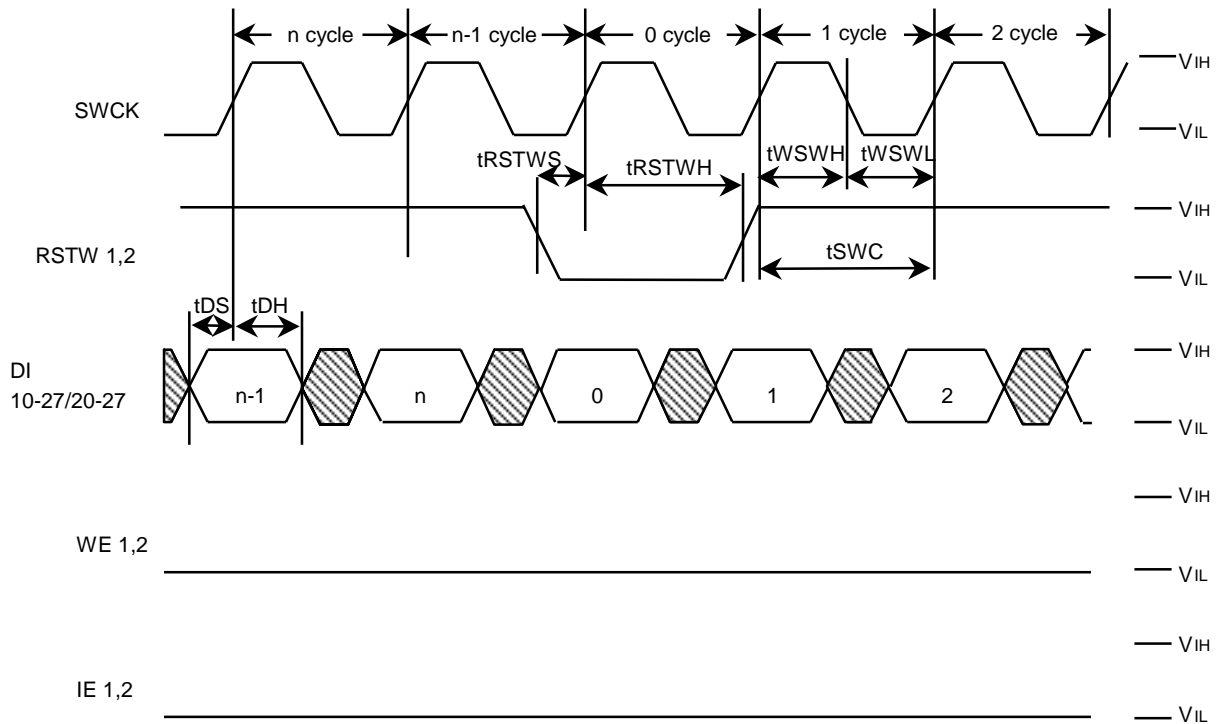

Write Cycle Timing (Write Enable) : MODE1=Vss , MODE2=Vcc

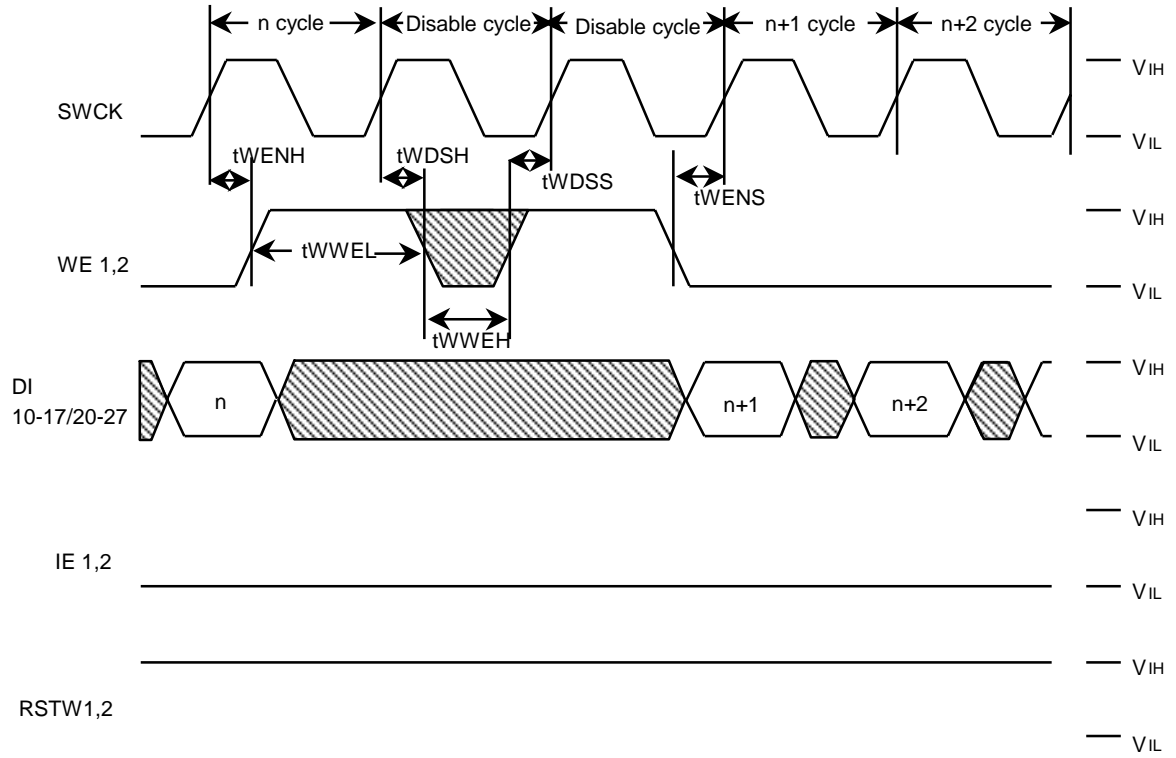

Write Cycle Timing (Input Enable) : MODE1=Vss , MODE2=Vcc

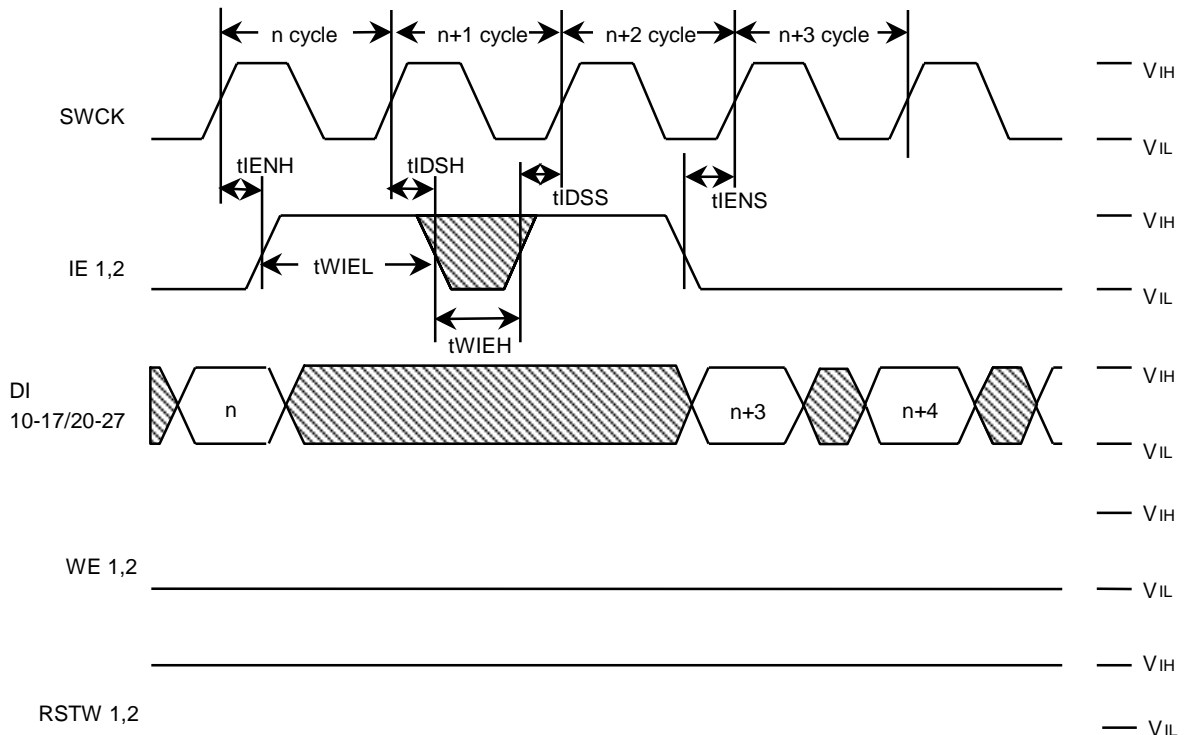

Read Cycle Timing (Read Reset) : MODE1=Vcc/Vss , MODE2=Vss

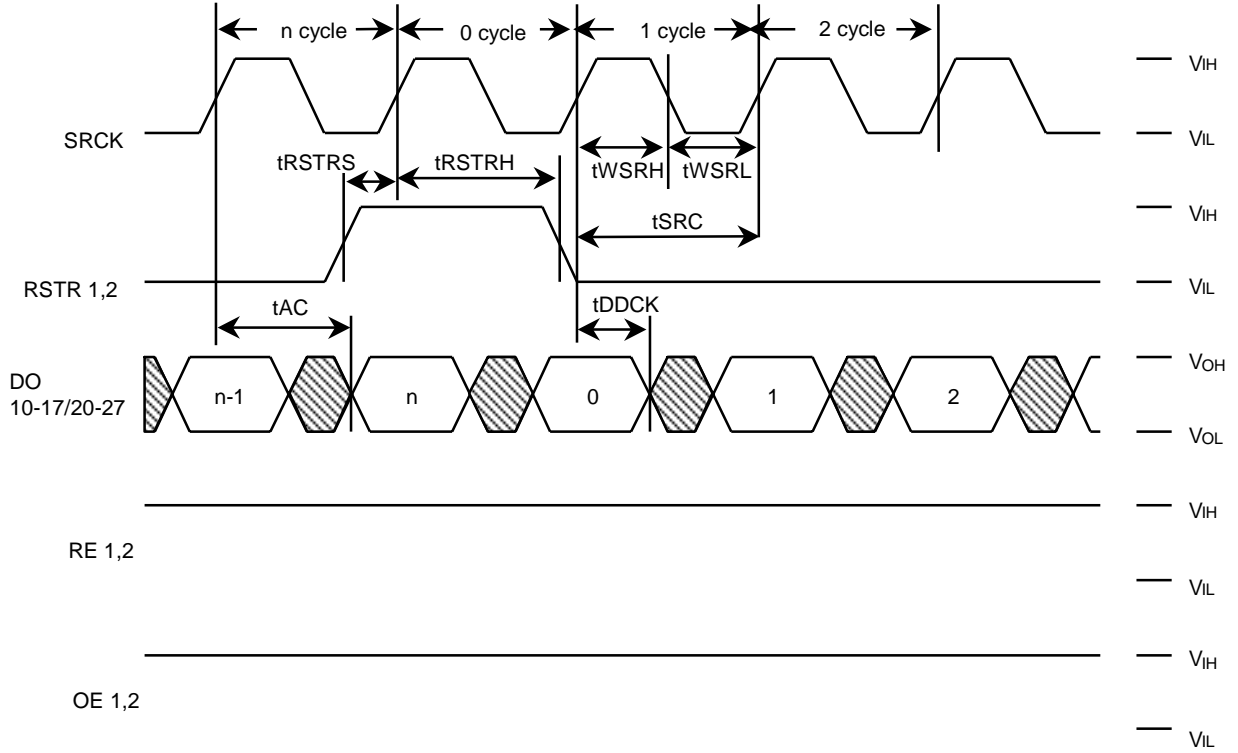

Read Cycle Timing (Read Enable) : MODE1=Vcc/Vss , MODE2=Vss

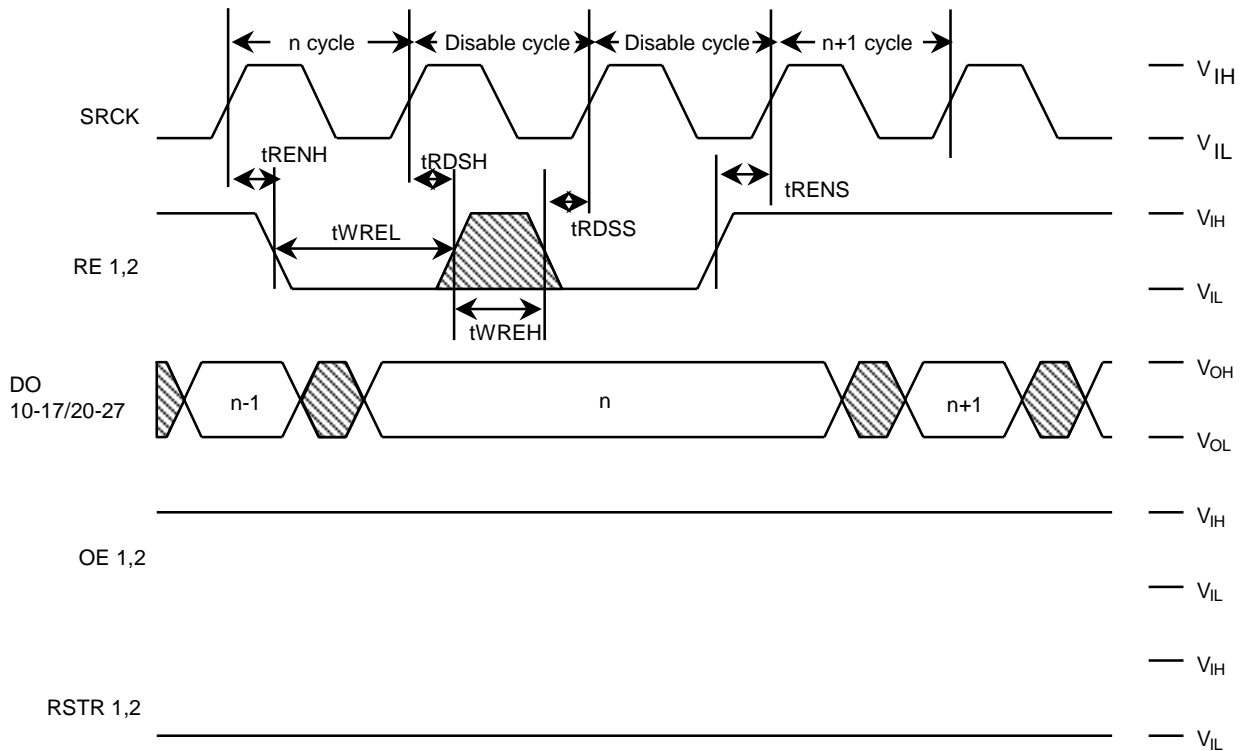

Read Cycle Timing (Output Enable) : MODE1=Vcc/Vss , MODE2=Vss

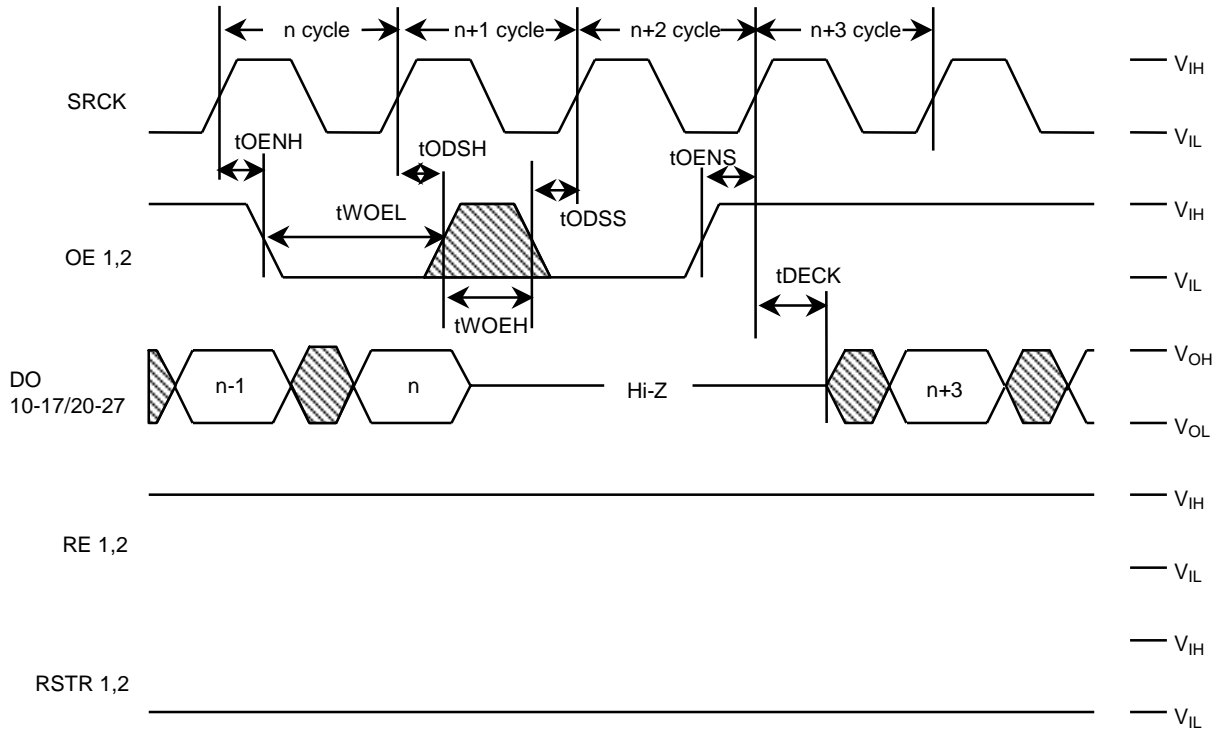

Read Cycle Timing (Read Reset) : MODE1=Vcc/Vss , MODE2=Vcc

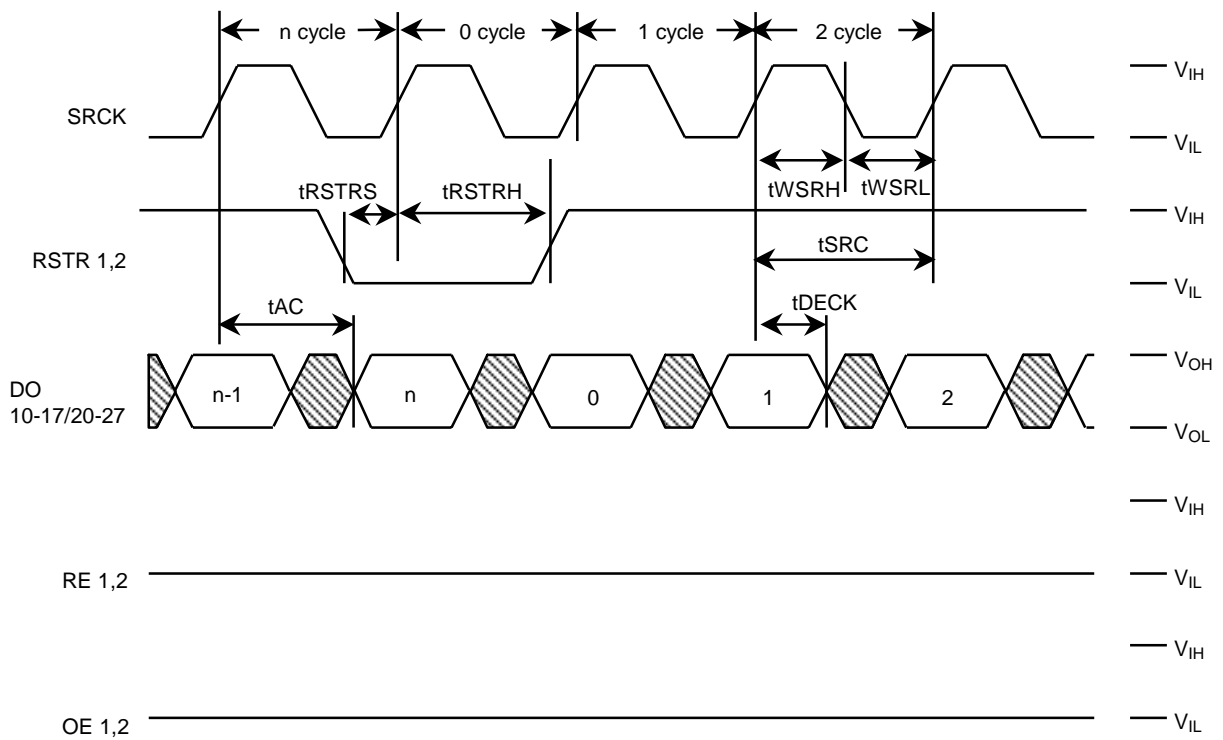

Read Cycle Timing (Read Enable) : MODE1=Vcc/Vss , MODE2=Vcc

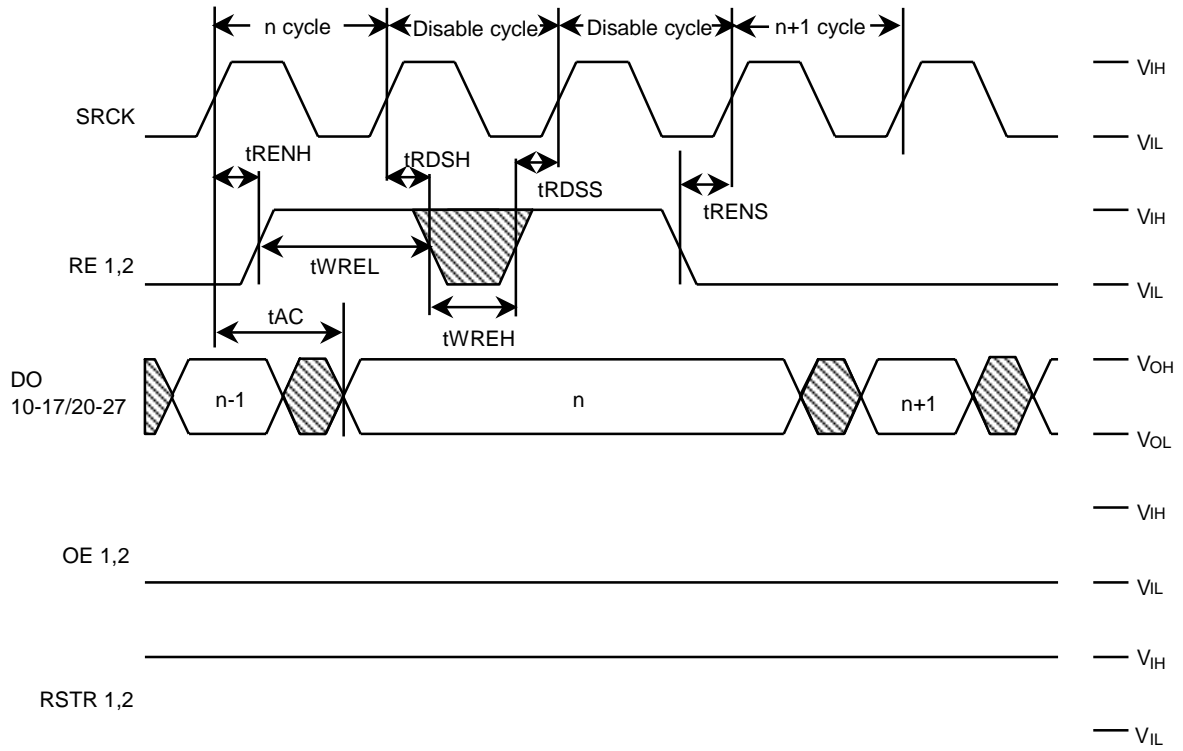

Read Cycle Timing (Output Enable) : MODE1=Vcc/Vss , MODE2=Vcc

