

# OKI Semiconductor

## MSC23109C/CL-xxDS3

1,048,576-Word × 9-Bit DRAM MODULE : FAST PAGE MODE TYPE

### DESCRIPTION

The OKI MSC23109C/CL-xxDS3 is a fully decoded 1,048,576-word × 9-bit CMOS Dynamic Random Access Memory Module composed of two 4-Mb DRAMs (1M × 4) in SOJ packages and one 1-Mb DRAM (1M × 1) in an SOJ package mounted with three decoupling capacitors on a 30-pin glass epoxy single-inline package. This module is generally used for memory expansion in parity applications such as workstations. The low-power version (CL) offers reduced power consumption for mobile computing applications like laptops and palmtops.

### FEATURES

- 1-Meg × 9-bit organization
- 30-Pin Socket Insertable Module  
MSC23109C/CL-xxDS3 : Solder tab
- Single 5 V supply ±10% tolerance
- Access times : 60, 70, 80 ns
- Input : TTL compatible
- Output : TTL compatible, 3-state
- Refresh : 1024 cycles/16 ms (128 ms : L-version)
- $\overline{\text{CAS}}$  before  $\overline{\text{RAS}}$  refresh,  $\overline{\text{CAS}}$  before  $\overline{\text{RAS}}$  hidden refresh,  $\overline{\text{RAS}}$ -only refresh capability
- Fast Page Mode capability

### PRODUCT FAMILY

Family	Access Time (Max.)			Cycle Time (Min.)	Power Dissipation	
	t <sub>RAC</sub>	t <sub>AA</sub>	t <sub>CAC</sub>		Operating (Max.)	Standby (Max.)
MSC23109C/CL-60DS3	60 ns	30 ns	15 ns	110 ns	1485 mW	16.5 mW/ 3.3 mW (L-version)
MSC23109C/CL-70DS3	70 ns	35 ns	20 ns	130 ns	1320 mW	
MSC23109C/CL-80DS3	80 ns	40 ns	20 ns	150 ns	1155 mW	

**PIN CONFIGURATION**  
**MSC23109C/CL-xxDS3**

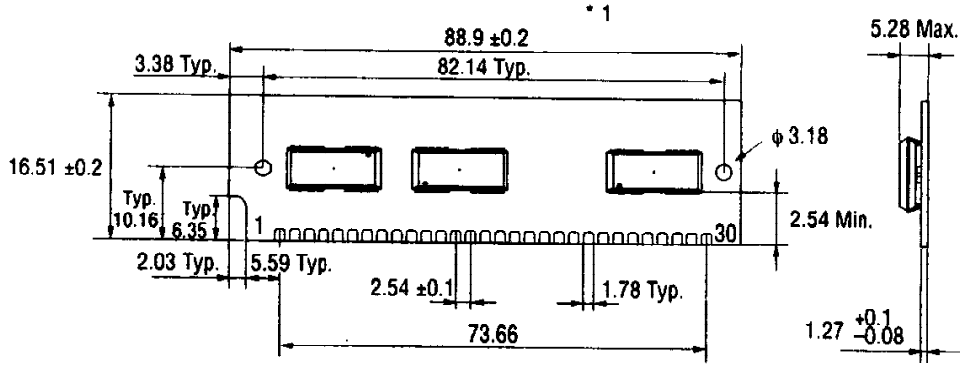

\*1 The common size difference of the board width 12.5 mm of its height is specified as  $\pm 0.2$ . The value above 12.5 mm is specified as  $\pm 0.5$ .

Pin No.	Pin Name	Pin No.	Pin Name	Pin No.	Pin Name
1	Vcc	11	A4	21	WE
2	CAS	12	A5	22	Vss
3	DQ0	13	DQ3	23	DQ6
4	A0	14	A6	24	NC
5	A1	15	A7	25	DQ7
6	DQ1	16	DQ4	26	Q8
7	A2	17	A8	27	RAS
8	A3	18	A9	28	CAS8
9	Vss	19	NC	29	D8
10	DQ2	20	DQ5	30	Vcc

**BLOCK DIAGRAM**

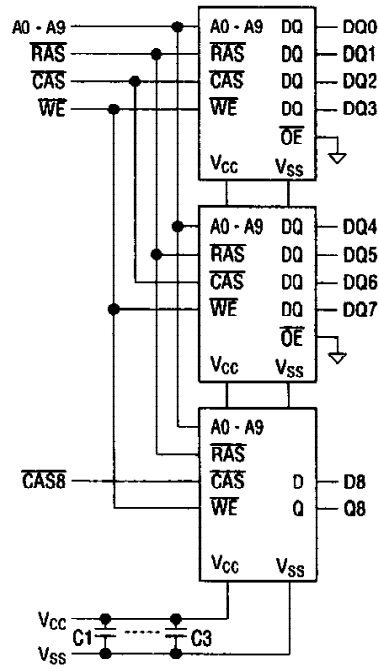

**ELECTRICAL CHARACTERISTICS****Absolute Maximum Ratings**

Parameter	Symbol	Rating	Unit
Voltage on Any Pin Relative to V <sub>SS</sub>	V <sub>IN</sub> , V <sub>OUT</sub>	-1.0 to 7.0	V
Voltage V <sub>CC</sub> Supply Relative to V <sub>SS</sub>	V <sub>CC</sub>	-1.0 to 7.0	V
Short Circuit Output Current	I <sub>OS</sub>	50	mA
Power Dissipation	P <sub>D</sub>	3	W
Operating Temperature	T <sub>opr</sub>	0 to 70	°C
Storage Temperature	T <sub>stg</sub>	-40 to 125	°C

Note: Permanent device damage may occur if ABSOLUTE MAXIMUM RATINGS are exceeded. Functional operation should be restricted to the conditions as detailed in the operational sections of this data sheet. Exposure to absolute maximum rating conditions for extended periods may affect device reliability.

**Recommended Operating Conditions**(T<sub>a</sub> = 0°C to 70°C)

Parameter	Symbol	Min.	Typ.	Max.	Unit
Power Supply Voltage	V <sub>CC</sub>	4.5	5.0	5.5	V
	V <sub>SS</sub>	0	0	0	V
Input High Voltage	V <sub>IH</sub>	2.4	—	6.5	V
Input Low Voltage	V <sub>IL</sub>	-1.0	—	0.8	V

**Capacitance**(T<sub>a</sub> = 25°C, f = 1 MHz)

Parameter	Symbol	Typ.	Max.	Unit
Input Capacitance (A0 - A9)	C <sub>IN1</sub>	—	24	pF
Input Capacitance (RAS, CAS, WE)	C <sub>IN2</sub>	—	26	pF
I/O Capacitance (DQ0 - DQ7)	C <sub>DQ</sub>	—	13	pF
Input Capacitance (CASB)	C <sub>IN3</sub>	—	11	pF
Input Capacitance (D8)	C <sub>IN4</sub>	—	11	pF
Output Capacitance (Q8)	C <sub>OUT</sub>	—	12	pF

Note: Capacitance measured with Boonton Meter.

DC Characteristics

(V<sub>CC</sub> = 5 V ±10%, T<sub>a</sub> = 0°C to 70°C)

Parameter	Symbol	Condition	MSC23109C/CL		MSC23109C/CL		MSC23109C/CL		Unit	Note
			-60DS3		-70DS3		-80DS3			
			Min.	Max.	Min.	Max.	Min.	Max.		
Input Leakage Current	I <sub>LI</sub>	0 V ≤ V <sub>I</sub> ≤ 6.5 V; All other pins not under test = 0 V	-30	30	-30	30	-30	30	μA	
Output Leakage Current	I <sub>LO</sub>	D <sub>OUT</sub> disable 0 V ≤ V <sub>O</sub> ≤ 5.5 V	-10	10	-10	10	-10	10	μA	
Output High Voltage	V <sub>OH</sub>	I <sub>OH</sub> = -5.0 mA	2.4	V <sub>CC</sub>	2.4	V <sub>CC</sub>	2.4	V <sub>CC</sub>	V	
Output Low Voltage	V <sub>OL</sub>	I <sub>OL</sub> = 4.2 mA	0	0.4	0	0.4	0	0.4	V	
Average Power Supply Current (Operating)	I <sub>CC1</sub>	RAS, CAS cycling, t <sub>RC</sub> = Min.	—	270	—	240	—	210	mA	1, 2
Power Supply Current (Standby)	I <sub>CC2</sub>	RAS, CAS = V <sub>IH</sub>	—	6	—	6	—	6	mA	1
		RAS, CAS	—	3	—	3	—	3	mA	1
		≥ V <sub>CC</sub> - 0.2 V	—	600	—	600	—	600	μA	1, 5
Average Power Supply Current (RAS-only Refresh)	I <sub>CC3</sub>	RAS cycling, CAS = V <sub>IH</sub> , t <sub>RC</sub> = Min.	—	270	—	240	—	210	mA	1, 2
Average Power Supply Current (CAS before RAS Refresh)	I <sub>CC6</sub>	RAS cycling, CAS before RAS, t <sub>RC</sub> = Min.	—	270	—	240	—	210	mA	1, 2
Average Power Supply Current (Fast Page Mode)	I <sub>CC7</sub>	RAS = V <sub>IL</sub> , CAS cycling, t <sub>PC</sub> = Min.	—	225	—	195	—	165	mA	1, 3
Average Power Supply Current (Battery Backup)	I <sub>CC10</sub>	t <sub>RC</sub> = 125 μs, CAS before RAS cycling	—	900	—	900	—	900	μA	1, 2 4, 5

- Notes: 1. Specified values are obtained with the output open.  
 2. Address can be changed once or less while RAS = V<sub>IL</sub>.  
 3. Address can be changed once or less while CAS = V<sub>IH</sub>.  
 4. V<sub>CC</sub> - 0.2 V ≤ V<sub>IH</sub> ≤ 6.5 V, -1.0 V ≤ V<sub>IL</sub> ≤ 0.2 V.  
 5. L-version.

## AC Characteristics (1/2)

(V<sub>CC</sub> = 5 V ±10%, T<sub>a</sub> = 0°C to 70°C) Note 1,2,3

Parameter	Symbol	MSC23109C/CL -60DS3		MSC23109C/CL -70DS3		MSC23109C/CL -80DS3		Unit	Note
		Min.	Max.	Min.	Max.	Min.	Max.		
Random Read or Write Cycle Time	t <sub>RC</sub>	120	—	130	—	150	—	ns	
Fast Page Mode Cycle Time	t <sub>PC</sub>	40	—	45	—	50	—	ns	
Access Time from RAS	t <sub>RAC</sub>	—	60	—	70	—	80	ns	4, 5, 6
Access Time from CAS	t <sub>CAC</sub>	—	15	—	20	—	20	ns	4, 5
Access Time from Column Address	t <sub>AA</sub>	—	30	—	35	—	40	ns	4, 6
Access Time from CAS Precharge	t <sub>CPA</sub>	—	35	—	40	—	45	ns	4
Output Low Impedance Time from CAS	t <sub>CLZ</sub>	0	—	0	—	0	—	ns	4
Output Buffer Turn-off Delay Time	t <sub>OFF</sub>	0	15	0	20	0	20	ns	7
Transition Time	t <sub>r</sub>	3	50	3	50	3	50	ns	3
Refresh Period	t <sub>REF</sub>	—	16	—	16	—	16	ms	
Refresh Period (L-version)	t <sub>REF</sub>	—	128	—	128	—	128	ms	
RAS Precharge Time	t <sub>RP</sub>	50	—	50	—	60	—	ns	
RAS Pulse Width	t <sub>RAS</sub>	60	10K	70	10K	80	10K	ns	
RAS Pulse Width (Fast Page Mode)	t <sub>RASP</sub>	60	100K	70	100K	80	100K	ns	
RAS Hold Time	t <sub>RSH</sub>	15	—	20	—	20	—	ns	
CAS Precharge Time	t <sub>CP</sub>	10	—	10	—	10	—	ns	
CAS Pulse Width	t <sub>CAS</sub>	15	10K	20	10K	20	10K	ns	
CAS Hold Time	t <sub>CSH</sub>	60	—	70	—	80	—	ns	
CAS to RAS Precharge Time	t <sub>CRP</sub>	5	—	5	—	5	—	ns	
RAS to CAS Delay Time	t <sub>RCD</sub>	20	45	20	50	20	60	ns	5
RAS to Column Address Delay Time	t <sub>RAD</sub>	15	30	15	35	15	40	ns	6
Row Address Set-up Time	t <sub>ASR</sub>	0	—	0	—	0	—	ns	
Row Address Hold Time	t <sub>RAH</sub>	10	—	10	—	10	—	ns	
Column Address Set-up Time	t <sub>ASC</sub>	0	—	0	—	0	—	ns	
Column Address Hold Time	t <sub>CAH</sub>	15	—	15	—	15	—	ns	
Column Address Hold Time from RAS	t <sub>AR</sub>	50	—	55	—	60	—	ns	
Column Address to RAS Lead Time	t <sub>RAL</sub>	30	—	35	—	40	—	ns	

## AC Characteristics (2/2)

(V<sub>CC</sub> = 5 V ±10%, T<sub>a</sub> = 0°C to 70°C) Note 1,2,3

Parameter	Symbol	MSC23109C/CL		MSC23109C/CL		MSC23109C/CL		Unit	Note
		-80DS3		-70DS3		-80DS3			
		Min.	Max.	Min.	Max.	Min.	Max.		
Read Command Set-up Time	t <sub>RCS</sub>	0	—	0	—	0	—	ns	
Read Command Hold Time	t <sub>RCH</sub>	0	—	0	—	0	—	ns	8
Read Command Hold Time referenced to $\overline{\text{RAS}}$	t <sub>RRH</sub>	0	—	0	—	0	—	ns	8
Write Command Set-up Time	t <sub>WCS</sub>	0	—	0	—	0	—	ns	
Write Command Hold Time	t <sub>WCH</sub>	10	—	15	—	15	—	ns	
Write Command Hold Time from $\overline{\text{RAS}}$	t <sub>WCR</sub>	50	—	55	—	60	—	ns	
Write Command Pulse Width	t <sub>WP</sub>	10	—	15	—	15	—	ns	
Write Command to $\overline{\text{RAS}}$ Lead Time	t <sub>RWL</sub>	15	—	20	—	20	—	ns	
Write Command to $\overline{\text{CAS}}$ Lead Time	t <sub>CWL</sub>	15	—	20	—	20	—	ns	
Data-in Set-up Time	t <sub>DS</sub>	0	—	0	—	0	—	ns	
Data-in Hold Time	t <sub>DH</sub>	15	—	15	—	15	—	ns	
Data-in Hold Time from $\overline{\text{RAS}}$	t <sub>DHR</sub>	50	—	55	—	60	—	ns	
$\overline{\text{CAS}}$ Active Delay Time from $\overline{\text{RAS}}$ Precharge	t <sub>APC</sub>	10	—	10	—	10	—	ns	
$\overline{\text{RAS}}$ to $\overline{\text{CAS}}$ Set-up Time ( $\overline{\text{CAS}}$ before $\overline{\text{RAS}}$ )	t <sub>CSR</sub>	10	—	10	—	10	—	ns	
$\overline{\text{RAS}}$ to $\overline{\text{CAS}}$ Hold Time ( $\overline{\text{CAS}}$ before $\overline{\text{RAS}}$ )	t <sub>CHR</sub>	30	—	30	—	30	—	ns	
$\overline{\text{CAS}}$ Precharge Time (Refresh Counter Test)	t <sub>CPT</sub>	40	—	40	—	40	—	ns	
$\overline{\text{WE}}$ to $\overline{\text{RAS}}$ Precharge Time ( $\overline{\text{CAS}}$ before $\overline{\text{RAS}}$ )	t <sub>WRP</sub>	10	—	10	—	10	—	ns	
$\overline{\text{WE}}$ Hold Time from $\overline{\text{RAS}}$ ( $\overline{\text{CAS}}$ before $\overline{\text{RAS}}$ )	t <sub>WRH</sub>	10	—	10	—	10	—	ns	

- Notes:
1. A start-up delay of 200  $\mu$ s is required after power-up followed by a minimum of eight initialization cycles ( $\overline{\text{RAS}}$ -only refresh or  $\overline{\text{CAS}}$  before  $\overline{\text{RAS}}$  refresh) before proper device operation is achieved.  
When using the internal refresh counter, a minimum of eight  $\overline{\text{CAS}}$  before  $\overline{\text{RAS}}$  initialization cycles is required.
  2. AC measurement assume  $t_T = 5$  ns.
  3.  $V_{IH}$  (Min.) and  $V_{IL}$  (Max.) are reference levels for measuring input timing signals. Transition times are measured between  $V_{IH}$  and  $V_{IL}$ .
  4. Measured with a load circuit equivalent to 2 TTL loads and 100 pF.
  5. Operation within the  $t_{RCD}$  (Max.) limit ensures that  $t_{RAC}$  (Max.) can be met.  $t_{RCD}$  (Max.) is specified as a reference point only. If  $t_{RCD}$  is greater than the specified  $t_{RCD}$  (Max.) limit, access time is controlled by  $t_{CAC}$ .
  6. Operation within the  $t_{RAD}$  (Max.) limit ensures that  $t_{RAC}$  (Max.) can be met.  $t_{RAD}$  (Max.) is specified as a reference point only. If  $t_{RAD}$  is greater than the specified  $t_{RAD}$  (Max.) limit, access time is controlled by  $t_{AA}$ .
  7.  $t_{OFF}$  (Max.) defines the time at which the output achieves an open circuit condition and is not referenced to output voltage levels.
  8.  $t_{RCH}$  or  $t_{RRH}$  must be satisfied for a read cycle.

**See ADDENDUM B for AC Timing Waveforms**