

OKI Semiconductor

MSC2383257A-xxBS16/DS16

8,388,608-Word × 32-Bit DRAM MODULE : FAST PAGE MODE TYPE WITH EDO

DESCRIPTION

The Oki MSC2383257A-xxBS16/DS16 is a fully decoded 8,388,608-word × 32-bit CMOS dynamic random access memory composed of sixteen 16-Mb DRAMs (4M × 4) in SOJ. The mounting of sixteen DRAMs together with decoupling capacitors on a 72-pin glass epoxy SIMM Package supports any application where high density and large capacity of storage memory are required.

FEATURES

- 8,388,608-word × 32-bit organization
- 72-pin SIMM
MSC2383257A-xxBS16 : Gold tab
MSC2383257A-xxDS16 : Solder tab
- Single 5 V supply ±10% tolerance
- Input : TTL compatible
- Output : TTL compatible, 3-state, nonlatch
- Refresh : 2048 cycles/32 ms
- $\overline{\text{CAS}}$ before $\overline{\text{RAS}}$ refresh, $\overline{\text{CAS}}$ before $\overline{\text{RAS}}$ hidden refresh, $\overline{\text{RAS}}$ -only refresh capability
- Multi-bit test mode capability
- Fast Page Mode with EDO capability

PRODUCT FAMILY

Family	Access Time (Max.)			Cycle Time (Min.)	Power Dissipation	
	t _{RAC}	t _{AA}	t _{CAC}		Operating (Max.)	Standby (Max.)
MSC2383257A-60BS16/DS16	60 ns	30 ns	15 ns	110 ns	5500 mW	88 mW
MSC2383257A-70BS16/DS16	70 ns	35 ns	20 ns	130 ns	5060 mW	

BLOCK DIAGRAM

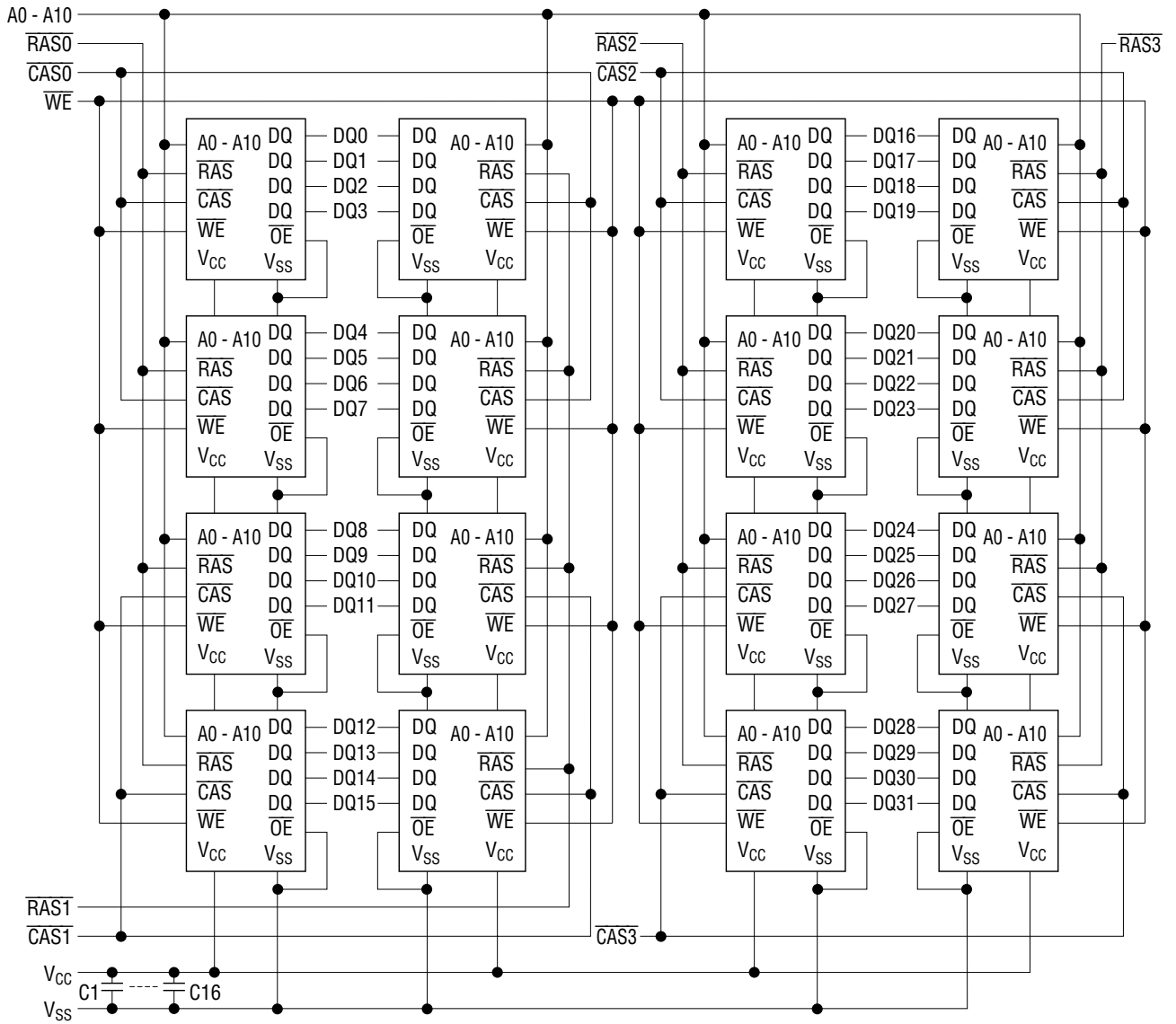

ELECTRICAL CHARACTERISTICS

Absolute Maximum Ratings

Parameter	Symbol	Rating	Unit
Voltage on Any Pin Relative to V_{SS}	V_{IN}, V_{OUT}	-1.0 to 7.0	V
Voltage V_{CC} Supply Relative to V_{SS}	V_{CC}	-1.0 to 7.0	V
Short Circuit Output Current	I_{OS}	50	mA
Power Dissipation	P_D	16	W
Operating Temperature	T_{opr}	0 to 70	°C
Storage Temperature	T_{stg}	-40 to 125	°C

Note: Permanent device damage may occur if ABSOLUTE MAXIMUM RATINGS are exceeded. Functional operation should be restricted to the conditions as detailed in the operational sections of this data sheet. Exposure to absolute maximum rating conditions for extended periods may affect device reliability.

Recommended Operating Conditions

($T_a = 0^\circ\text{C}$ to 70°C)

Parameter	Symbol	Min.	Typ.	Max.	Unit
Power Supply Voltage	V_{CC}	4.5	5.0	5.5	V
	V_{SS}	0	0	0	V
Input High Voltage	V_{IH}	2.4	—	6.5	V
Input Low Voltage	V_{IL}	-1.0	—	0.8	V

Capacitance

($T_a = 25^\circ\text{C}$, $f = 1\text{ MHz}$)

Parameter	Symbol	Typ.	Max.	Unit
Input Capacitance (A0 - A10)	C_{IN1}	—	109	pF
Input Capacitance (\overline{WE})	C_{IN2}	—	125	pF
Input Capacitance ($\overline{RAS0} - \overline{RAS3}$)	C_{IN3}	—	35	pF
Input Capacitance ($\overline{CAS0} - \overline{CAS3}$)	C_{IN4}	—	35	pF
I/O Capacitance (DQ0 - DQ31)	C_{DQ}	—	26	pF

Note : Capacitance measured with Boonton Meter.

DC Characteristics

($V_{CC} = 5\text{ V} \pm 10\%$, $T_a = 0^\circ\text{C}$ to 70°C)

Parameter	Symbol	Condition	MSC2383257A -60BS16/DS16		MSC2383257A -70BS16/DS16		Unit	Note
			Min.	Max.	Min.	Max.		
Input Leakage Current	I_{LI}	$0\text{ V} \leq V_I \leq 6.5\text{ V}$; All other pins not under test = 0 V	-160	160	-160	160	μA	
Output Leakage Current	I_{LO}	D_{OUT} disable $0\text{ V} \leq V_O \leq 5.5\text{ V}$	-20	20	-20	20	μA	
Output High Voltage	V_{OH}	$I_{OH} = -5.0\text{ mA}$	2.4	V_{CC}	2.4	V_{CC}	V	
Output Low Voltage	V_{OL}	$I_{OL} = 4.2\text{ mA}$	0	0.4	0	0.4	V	
Average Power Supply Current (Operating)	I_{CC1}	\overline{RAS} , \overline{CAS} cycling, $t_{RC} = \text{Min.}$	—	1000	—	920	mA	1, 2
Power Supply Current (Standby)	I_{CC2}	\overline{RAS} , $\overline{CAS} = V_{IH}$	—	32	—	32	mA	1
		\overline{RAS} , \overline{CAS} $\geq V_{CC} - 0.2\text{ V}$	—	16	—	16	mA	1
Average Power Supply Current (\overline{RAS} -only Refresh)	I_{CC3}	\overline{RAS} cycling, $\overline{CAS} = V_{IH}$, $t_{RC} = \text{Min.}$	—	1000	—	920	mA	1, 2
Average Power Supply Current (\overline{CAS} before \overline{RAS} Refresh)	I_{CC6}	\overline{RAS} cycling, \overline{CAS} before \overline{RAS} , $t_{RC} = \text{Min.}$	—	1000	—	920	mA	1, 2
Average Power Supply Current (Fast Page Mode)	I_{CC7}	$\overline{RAS} = V_{IL}$, \overline{CAS} cycling, $t_{HPC} = \text{Min.}$	—	1160	—	1080	mA	1, 3

- Notes:
1. I_{CC} Max. is specified as I_{CC} for output open condition.
 2. Address can be changed once or less while $\overline{RAS} = V_{IL}$.
 3. Address can be changed once or less while $\overline{CAS} = V_{IH}$.

AC Characteristics (1/2)

(V_{CC} = 5 V ±10%, T_a = 0°C to 70°C) Note 1,2,3,10,11

Parameter	Symbol	MSC2383257A -60BS16/DS16		MSC2383257A -70BS16/DS16		Unit	Note
		Min.	Max.	Min.	Max.		
		Random Read or Write Cycle Time	t _{RC}	110	—		
Fast Page Mode Cycle Time	t _{HPC}	25	—	30	—	ns	
Access Time from $\overline{\text{RAS}}$	t _{RAC}	—	60	—	70	ns	4, 5, 6
Access Time from $\overline{\text{CAS}}$	t _{CAC}	—	15	—	20	ns	4, 5
Access Time from Column Address	t _{AA}	—	30	—	35	ns	4, 6
Access Time from $\overline{\text{CAS}}$ Precharge	t _{CPA}	—	35	—	40	ns	4
Output Low Impedance Time from $\overline{\text{CAS}}$	t _{CLZ}	0	—	0	—	ns	4
Output Hold Time from $\overline{\text{CAS}}$ Low	t _{DOH}	5	—	5	—	ns	
$\overline{\text{CAS}}$ to Data Output Buffer Turn-off Delay Time	t _{CEZ}	0	15	0	20	ns	7, 8
$\overline{\text{RAS}}$ to Data Output Buffer Turn-off Delay Time	t _{REZ}	0	15	0	20	ns	7, 8
$\overline{\text{WE}}$ to Data Output Buffer Turn-off Delay Time	t _{WEZ}	0	15	0	20	ns	7
Transition Time	t _T	2	50	2	50	ns	3
Refresh Period	t _{REF}	—	32	—	32	ms	
$\overline{\text{RAS}}$ Precharge Time	t _{RP}	40	—	50	—	ns	
$\overline{\text{RAS}}$ Pulse Width	t _{RAS}	60	10k	70	10k	ns	
$\overline{\text{RAS}}$ Pulse Width (Fast Page Mode)	t _{RASP}	60	100k	70	100k	ns	
$\overline{\text{RAS}}$ Hold Time	t _{RSH}	15	—	20	—	ns	
$\overline{\text{CAS}}$ Precharge Time	t _{CP}	10	—	10	—	ns	
$\overline{\text{CAS}}$ Pulse Width	t _{CAS}	10	10k	10	10k	ns	
$\overline{\text{RAS}}$ Low to $\overline{\text{CAS}}$ High Delay Time	t _{CSH}	40	—	45	—	ns	
$\overline{\text{CAS}}$ High to $\overline{\text{RAS}}$ Low Delay Time	t _{CRP}	10	—	10	—	ns	
$\overline{\text{RAS}}$ Hold Time from $\overline{\text{CAS}}$ Precharge	t _{RHCP}	35	—	40	—	ns	
$\overline{\text{RAS}}$ to $\overline{\text{CAS}}$ Delay Time	t _{RCD}	20	45	20	50	ns	5
$\overline{\text{RAS}}$ to Column Address Delay Time	t _{RAD}	15	30	15	35	ns	6
$\overline{\text{RAS}}$ to Second $\overline{\text{CAS}}$ Delay Time	t _{RS CD}	60	—	70	—	ns	
Row Address Set-up Time	t _{ASR}	0	—	0	—	ns	
Row Address Hold Time	t _{RAH}	10	—	10	—	ns	
Column Address Set-up Time	t _{ASC}	0	—	0	—	ns	
Column Address Hold Time	t _{CAH}	10	—	15	—	ns	
Column Address Hold Time from $\overline{\text{RAS}}$	t _{AR}	40	—	45	—	ns	
Column Address to $\overline{\text{RAS}}$ Lead Time	t _{RAL}	30	—	35	—	ns	

AC Characteristics (2/2)

(V_{CC} = 5 V ±10%, Ta = 0°C to 70°C) Note 1,2,3,10,11

Parameter	Symbol	MSC2383257A -60BS16/DS16		MSC2383257A -70BS16/DS16		Unit	Note
		Min.	Max.	Min.	Max.		
		Read Command Set-up Time	t _{RCS}	0	—		
Read Command Hold Time	t _{RCH}	0	—	0	—	ns	9
Read Command Hold Time referenced to $\overline{\text{RAS}}$	t _{RRH}	0	—	0	—	ns	9
Write Command Set-up Time	t _{WCS}	0	—	0	—	ns	
Write Command Hold Time	t _{WCH}	10	—	15	—	ns	
Write Command Hold Time from $\overline{\text{RAS}}$	t _{WCR}	45	—	50	—	ns	
Write Command Pulse Width	t _{WPE}	10	—	10	—	ns	
Write Command Pulse Width (Output Disable)	t _{WPE}	5	—	10	—	ns	
Write Command to $\overline{\text{RAS}}$ Lead Time	t _{RWL}	15	—	20	—	ns	
Write Command to $\overline{\text{CAS}}$ Lead Time	t _{CWL}	15	—	20	—	ns	
Data-in Set-up Time	t _{DS}	0	—	0	—	ns	
Data-in Hold Time	t _{DH}	15	—	15	—	ns	
Data-in Hold Time from $\overline{\text{RAS}}$	t _{DHR}	40	—	45	—	ns	
$\overline{\text{CAS}}$ Active Delay Time from $\overline{\text{RAS}}$ Precharge	t _{RPC}	10	—	10	—	ns	
$\overline{\text{RAS}}$ to $\overline{\text{CAS}}$ Set-up Time ($\overline{\text{CAS}}$ before $\overline{\text{RAS}}$)	t _{CSR}	10	—	10	—	ns	
$\overline{\text{RAS}}$ to $\overline{\text{CAS}}$ Hold Time ($\overline{\text{CAS}}$ before $\overline{\text{RAS}}$)	t _{CHR}	20	—	20	—	ns	
$\overline{\text{WE}}$ to $\overline{\text{RAS}}$ Precharge Time ($\overline{\text{CAS}}$ before $\overline{\text{RAS}}$)	t _{WRP}	10	—	10	—	ns	
$\overline{\text{WE}}$ Hold Time from $\overline{\text{RAS}}$ ($\overline{\text{CAS}}$ before $\overline{\text{RAS}}$)	t _{WRH}	10	—	10	—	ns	
$\overline{\text{RAS}}$ to $\overline{\text{WE}}$ Set-up Time (Test Mode)	t _{WTS}	10	—	10	—	ns	
$\overline{\text{RAS}}$ to $\overline{\text{WE}}$ Hold Time (Test Mode)	t _{WTH}	20	—	20	—	ns	

- Notes:
1. A start-up delay of 200 μ s is required after power-up, followed by a minimum of eight initialization cycles ($\overline{\text{RAS}}$ -only refresh or $\overline{\text{CAS}}$ before $\overline{\text{RAS}}$ refresh) before proper device operation is achieved.
 2. The AC characteristics assume $t_T = 5$ ns.
 3. V_{IH} (Min.) and V_{IL} (Max.) are reference levels for measuring input timing signals. Transition times (t_T) are measured between V_{IH} and V_{IL} .
 4. This parameter is measured with a load circuit equivalent to 2 TTL loads and 100 pF.
 5. Operation within the t_{RCD} (Max.) limit ensures that t_{RAC} (Max.) can be met. t_{RCD} (Max.) is specified as a reference point only. If t_{RCD} is greater than the specified t_{RCD} (Max.) limit, access time is controlled by t_{CAC} .
 6. Operation within the t_{RAD} (Max.) limit ensures that t_{RAC} (Max.) can be met. t_{RAD} (Max.) is specified as a reference point only. If t_{RAD} is greater than the specified t_{RAD} (Max.) limit, access time is controlled by t_{AA} .
 7. t_{CEZ} (Max.), t_{REZ} (Max.) and t_{WEZ} (Max.) define the time at which the output achieves the open circuit condition and are not referenced to output voltage levels.
 8. t_{CEZ} and t_{REZ} must be satisfied for open circuit condition.
 9. t_{RCH} or t_{RRH} must be satisfied for a read cycle.
 10. The test mode is initiated by performing a $\overline{\text{WE}}$ and $\overline{\text{CAS}}$ before $\overline{\text{RAS}}$ refresh cycle. This mode is latched and remains in effect until the exit cycle is generated. The test mode specified in this data sheet is an 8-bit parallel test function. CA0, CA1 and CA10 are not used. In a read cycle, if all internal bits are equal, the DQ pin will indicate a high level. If any internal bits are not equal, the DQ pin will indicate a low level. The test mode is cleared and the memory device returned to its normal operating state by performing a $\overline{\text{RAS}}$ -only refresh cycle or a $\overline{\text{CAS}}$ before $\overline{\text{RAS}}$ refresh cycle.
The 4M \times 32 module can be tested as a 512K \times 32 module in this test mode.
 11. In a test mode read cycle, the access time parameters are delayed by 5 ns. The test mode parameters are obtained by adding 5 ns to the normal read cycle values.

See ADDENDUM I for AC Timing Waveforms