

OKI Semiconductor

MSM5116160

1,048,576-Word × 16-Bit DYNAMIC RAM : FAST PAGE MODE TYPE

DESCRIPTION

The MSM5116160 is a 1,048,576-word × 16-bit dynamic RAM fabricated in OKI's CMOS silicon gate technology. The MSM5116160 achieves high integration, high-speed operation, and low-power consumption due to quadruple polysilicon double metal CMOS. The MSM5116160 is available in a 42-pin plastic SOJ or 50/44-pin plastic TSOP.

FEATURES

- 1,048,576-word × 16-bit configuration
- Single 5 V power supply, ±10% tolerance
- Input : TTL compatible, low input capacitance
- Output : TTL compatible, 3-state
- Refresh : 4096 cycles/64 ms
- Fast page mode, read modify write capability
- $\overline{\text{CAS}}$ before $\overline{\text{RAS}}$ refresh, hidden refresh, $\overline{\text{RAS}}$ -only refresh capability
- Package options:
 - 42-Pin 400 mil plastic SOJ (SOJ42-P-400) (Product : MSM5116160-xxJS)
 - 50/44-Pin 400 mil plastic TSOP (TSOP50/44-P-400/0.8-K) (Product : MSM5116160-xxTS-K)
 - (TSOP50/44-P-400/0.8-L) (Product : MSM5116160-xxTS-L)xx indicates speed rank.

PRODUCT FAMILY

Family	Access Time (Max.)				Cycle Time (Min.)	Power Dissipation	
	t _{TRAC}	t _{AA}	t _{CAC}	t _{OEA}		Operating (Max.)	Standby (Max.)
MSM5116160-70	70 ns	35 ns	20 ns	20 ns	130 ns	660 mW	5.5 mW
MSM5116160-80	80 ns	40 ns	20 ns	20 ns	150 ns	605 mW	

PIN CONFIGURATION (TOP VIEW)

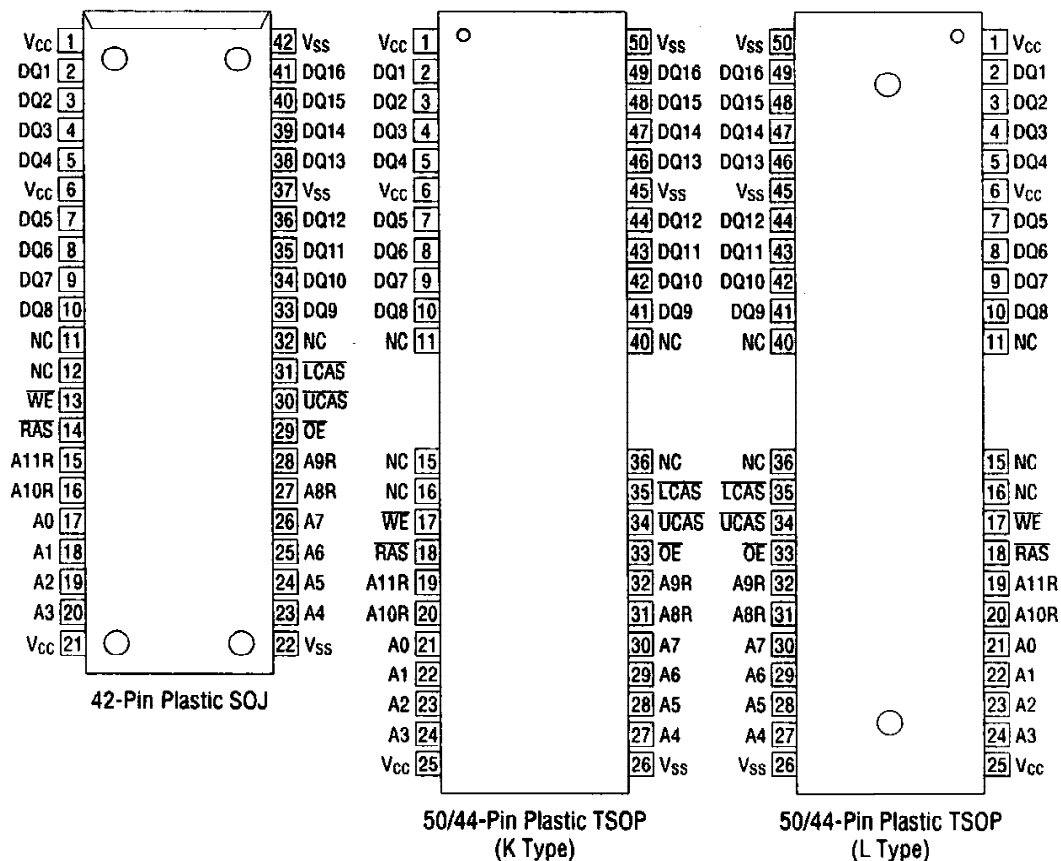

Pin Name	Function
A0 - A7, A8R - A11R	Address Input
RAS	Row Address Strobe
LCAS	Lower Byte Column Address Strobe
UCAS	Upper Byte Column Address Strobe
DQ1 - DQ16	Data Input/Data Output
OE	Output Enable
WE	Write Enable
V _{CC}	Power Supply (5 V)
V _{SS}	Ground (0 V)
NC	No Connection

Note : The same power supply voltage must be provided to every V_{CC} pin, and the same GND voltage level must be provided to every V_{SS} pin.

BLOCK DIAGRAM

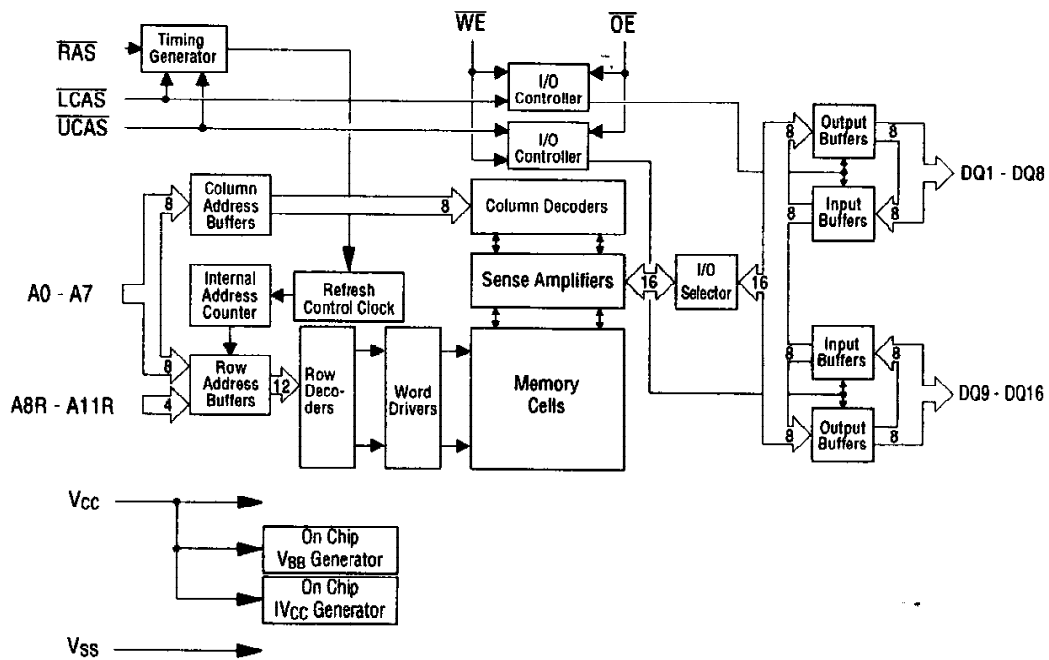

FUNCTION TABLE

Input Pin					DQ Pin		Function Mode
RAS	LCAS	UCAS	WE	OE	DQ1 - DQ8	DQ9 - DQ16	
H	*	*	*	*	High-Z	High-Z	Standby
L	H	H	*	*	High-Z	High-Z	Refresh
L	L	H	H	L	D _{OUT}	High-Z	Lower Byte Read
L	H	L	H	L	High-Z	D _{OUT}	Upper Byte Read
L	L	L	H	L	D _{OUT}	D _{OUT}	Word Read
L	L	H	L	H	D _{IN}	Don't Care	Lower Byte Write
L	H	L	L	H	Don't Care	D _{IN}	Upper Byte Write
L	L	L	L	H	D _{IN}	D _{IN}	Word Write
L	L	L	H	H	High-Z	High-Z	—

*: "H" or "L"

ELECTRICAL CHARACTERISTICS**Absolute Maximum Ratings**

Parameter	Symbol *	Rating	Unit
Voltage on Any Pin Relative to V _{SS}	V _T	-1.0 to 7.0	V
Short Circuit Output Current	I _{OS}	50	mA
Power Dissipation	P _D *	1	W
Operating Temperature	T _{opr}	0 to 70	°C
Storage Temperature	T _{stg}	-55 to 150	°C

*: T_a = 25°C**Recommended Operating Conditions**(T_a = 0°C to 70°C)

Parameter	Symbol	Min.	Typ.	Max.	Unit
Power Supply Voltage	V _{CC}	4.5	5.0	5.5	V
	V _{SS}	0	0	0	V
Input High Voltage	V _{IH}	2.4	—	6.5	V
Input Low Voltage	V _{IL}	-1.0	—	0.8	V

Capacitance(V_{CC} = 5 V ±10%, T_a = 25°C, f = 1 MHz)

Parameter	Symbol	Typ.	Max.	Unit
Input Capacitance (A0 - A7, A8R - A11R)	C _{IN1}	—	5	pF
Input Capacitance (RAS, LCAS, UCAS, WE, OE)	C _{IN2}	—	7	pF
Output Capacitance (DQ1 - DQ16)	C _{I/O}	—	7	pF

DC Characteristics

($V_{CC} = 5\text{ V} \pm 10\%$, $T_a = 0^\circ\text{C}$ to 70°C)

Parameter	Symbol	Condition	MSM5116160-70		MSM5116160-80		Unit	Note
			Min.	Max.	Min.	Max.		
Output High Voltage	V_{OH}	$I_{OH} = -5.0\text{ mA}$	2.4	V_{CC}	2.4	V_{CC}	V	
Output Low Voltage	V_{OL}	$I_{OL} = 4.2\text{ mA}$	0	0.4	0	0.4		
Input Leakage Current	I_{LI}	$0\text{ V} \leq V_I \leq 6.5\text{ V}$; All other pins not under test = 0 V	-10	10	-10	10	μA	
Output Leakage Current	I_{LO}	DQ disable $0\text{ V} \leq V_O \leq 5.5\text{ V}$	-10	10	-10	10	μA	
Average Power Supply Current (Operating)	I_{CC1}	$\overline{\text{RAS}}$, $\overline{\text{CAS}}$ cycling, $t_{RC} = \text{Min.}$	—	120	—	110	mA	1, 2
Power Supply Current (Standby)	I_{CC2}	$\overline{\text{RAS}}, \overline{\text{CAS}} = V_{IH}$	—	2	—	2	mA	1
		$\overline{\text{RAS}}, \overline{\text{CAS}} \geq V_{CC} - 0.2\text{ V}$	—	1	—	1		
Average Power Supply Current ($\overline{\text{RAS}}$ -only Refresh)	I_{CC3}	$\overline{\text{RAS}}$ cycling, $\overline{\text{CAS}} = V_{IH}$, $t_{RC} = \text{Min.}$	—	120	—	110	mA	1, 2
Power Supply Current (Standby)	I_{CC5}	$\overline{\text{RAS}} = V_{IH}$, $\overline{\text{CAS}} = V_{IL}$, DQ = enable	—	5	—	5	mA	1
Average Power Supply Current ($\overline{\text{CAS}}$ before $\overline{\text{RAS}}$ Refresh)	I_{CC6}	$\overline{\text{RAS}}$ cycling, $\overline{\text{CAS}}$ before $\overline{\text{RAS}}$	—	120	—	110	mA	1, 2
Average Power Supply Current (Fast Page Mode)	I_{CC7}	$\overline{\text{RAS}} = V_{IL}$, $\overline{\text{CAS}}$ cycling, $t_{PC} = \text{Min.}$	—	110	—	100	mA	1, 3

- Notes :
1. I_{CC} Max. is specified as I_{CC} for output open condition.
 2. Address can be changed once or less while $\overline{\text{RAS}} = V_{IL}$.
 3. Address can be changed once or less while $\overline{\text{CAS}} = V_{IH}$.

AC Characteristics (1/2)

(V_{CC} = 5 V ±10%, T_a = 0°C to 70°C) Note 1, 2, 3

Parameter	Symbol	MSM5116160-70		MSM5116160-80		Unit	Note
		Min.	Max.	Min.	Max.		
Random Read or Write Cycle Time	t _{RC}	130	—	150	—	ns	
Read Modify Write Cycle Time	t _{RWC}	180	—	200	—	ns	
Fast Page Mode Cycle Time	t _{PC}	45	—	50	—	ns	
Fast Page Mode Read Modify Write Cycle Time	t _{PRWC}	95	—	100	—	ns	
Access Time from $\overline{\text{RAS}}$	t _{RAC}	—	70	—	80	ns	4, 5, 6
Access Time from $\overline{\text{CAS}}$	t _{CAC}	—	20	—	20	ns	4, 5
Access Time from Column Address	t _{AA}	—	35	—	40	ns	4, 6
Access Time from $\overline{\text{CAS}}$ Precharge	t _{CPA}	—	40	—	45	ns	4, 12
Access Time from $\overline{\text{OE}}$	t _{OEA}	—	20	—	20	ns	4
Output Low Impedance Time from $\overline{\text{CAS}}$	t _{CLZ}	0	—	0	—	ns	4
$\overline{\text{CAS}}$ to Data Output Buffer Turn-off Delay Time	t _{OFF}	0	15	0	15	ns	7
$\overline{\text{OE}}$ to Data Output Buffer Turn-off Delay Time	t _{OEZ}	0	15	0	15	ns	7
Transition Time	t _T	3	50	3	50	ns	3
Refresh Period	t _{REF}	—	64	—	64	ms	
$\overline{\text{RAS}}$ Precharge Time	t _{RP}	50	—	60	—	ns	
$\overline{\text{RAS}}$ Pulse Width	t _{RAS}	70	10,000	80	10,000	ns	
$\overline{\text{RAS}}$ Pulse Width (Fast Page Mode)	t _{RASP}	70	100,000	80	100,000	ns	
$\overline{\text{RAS}}$ Hold Time	t _{RSH}	20	—	20	—	ns	
$\overline{\text{RAS}}$ Hold Time referenced to $\overline{\text{OE}}$	t _{ROH}	20	—	20	—	ns	
$\overline{\text{CAS}}$ Precharge Time (Fast Page Mode)	t _{CP}	10	—	10	—	ns	14
$\overline{\text{CAS}}$ Pulse Width	t _{CAS}	20	10,000	20	10,000	ns	
$\overline{\text{CAS}}$ Hold Time	t _{CSH}	70	—	80	—	ns	
$\overline{\text{CAS}}$ to $\overline{\text{RAS}}$ Precharge Time	t _{CRP}	10	—	10	—	ns	12
$\overline{\text{CAS}}$ to $\overline{\text{RAS}}$ Precharge Time	t _{RHCP}	40	—	45	—	ns	12
$\overline{\text{RAS}}$ to $\overline{\text{CAS}}$ Delay Time	t _{RCD}	20	50	20	60	ns	5
$\overline{\text{RAS}}$ to Column Address Delay Time	t _{RAD}	15	35	15	40	ns	6
Row Address Set-up Time	t _{ASR}	0	—	0	—	ns	
Row Address Hold Time	t _{RAH}	10	—	10	—	ns	
Column Address Set-up Time	t _{ASC}	0	—	0	—	ns	11
Column Address Hold Time	t _{CAH}	15	—	15	—	ns	11
Column Address Hold Time from $\overline{\text{RAS}}$	t _{AR}	55	—	60	—	ns	
Column Address to $\overline{\text{RAS}}$ Lead Time	t _{RAL}	35	—	40	—	ns	
Read Command Set-up Time	t _{RCS}	0	—	0	—	ns	11
Read Command Hold Time	t _{RCH}	0	—	0	—	ns	8, 11
Read Command Hold Time referenced to $\overline{\text{RAS}}$	t _{RRH}	0	—	0	—	ns	8

AC Characteristics (2/2)

(V_{CC} = 5 V ±10%, T_a = 0°C to 70°C) Note 1, 2, 3

Parameter	Symbol	MSM5116160-70		MSM5116160-80		Unit	Note
		Min.	Max.	Min.	Max.		
Write Command Set-up Time	t _{WCS}	0	—	0	—	ns	9, 11
Write Command Hold Time	t _{WCH}	15	—	15	—	ns	11
Write Command Hold Time from RAS	t _{WCR}	55	—	60	—	ns	
Write Command Pulse Width	t _{WP}	15	—	15	—	ns	
OE Command Hold Time	t _{OEH}	20	—	20	—	ns	
Write Command to RAS Lead Time	t _{RWL}	20	—	20	—	ns	
Write Command to CAS Lead Time	t _{CWL}	20	—	20	—	ns	13
Data-in Set-up Time	t _{DS}	0	—	0	—	ns	10, 11
Data-in Hold Time	t _{DH}	15	—	15	—	ns	10, 11
Data-in Hold Time from RAS	t _{DHR}	55	—	60	—	ns	
OE to Data-in Delay Time	t _{OEED}	15	—	15	—	ns	
CAS to WE Delay Time	t _{CWD}	45	—	45	—	ns	9
Column Address to WE Delay Time	t _{AWD}	60	—	65	—	ns	9
RAS to WE Delay Time	t _{RWD}	95	—	105	—	ns	9
CAS Precharge WE Delay Time	t _{CPWD}	65	—	75	—	ns	9
CAS Active Delay Time from RAS Precharge	t _{RPC}	10	—	10	—	ns	11
RAS to CAS Set-up Time (CAS before RAS)	t _{CSR}	10	—	10	—	ns	11
RAS to CAS Hold Time (CAS before RAS)	t _{CHR}	15	—	15	—	ns	12
CAS Precharge Time (Refresh Counter Test)	t _{CPT}	40	—	40	—	ns	14

- Notes:
1. A start-up delay of 200 μ s is required after power-up, followed by a minimum of eight initialization cycles ($\overline{\text{RAS}}$ -only refresh or $\overline{\text{CAS}}$ before $\overline{\text{RAS}}$ refresh) before proper device operation is achieved.
 2. The AC characteristics assume $t_T = 5$ ns.
 3. V_{IH} (Min.) and V_{IL} (Max.) are reference levels for measuring input timing signals. Transition times (t_T) are measured between V_{IH} and V_{IL} .
 4. This parameter is measured with a load circuit equivalent to 2 TTL loads and 100 pF.
 5. Operation within the t_{RCD} (Max.) limit ensures that t_{RAC} (Max.) can be met. t_{RCD} (Max.) is specified as a reference point only. If t_{RCD} is greater than the specified t_{RCD} (Max.) limit, access time is controlled by t_{CAC} .
 6. Operation within the t_{RAD} (Max.) limit ensures that t_{RAC} (Max.) can be met. t_{RAD} (Max.) is specified as a reference point only. If t_{RAD} is greater than the specified t_{RAD} (Max.) limit, access time is controlled by t_{AA} .
 7. t_{OFF} (Max.) and t_{OEZ} (Max.) define the time at which the output achieves the open circuit condition and are not referenced to output voltage levels.
 8. t_{RCH} or t_{RRH} must be satisfied for a read cycle.
 9. t_{WCS} , t_{CWD} , t_{RWD} , t_{AWD} and t_{CPWD} are not restrictive operating parameters. They are included in the data sheet as electrical characteristics only. If $t_{WCS} \geq t_{WCS}$ (Min.), the cycle is an early write cycle and the data out will remain open circuit (high impedance) throughout the entire cycle. If $t_{CWD} \geq t_{CWD}$ (Min.), $t_{RWD} \geq t_{RWD}$ (Min.), $t_{AWD} \geq t_{AWD}$ (Min.) and $t_{CPWD} \geq t_{CPWD}$ (Min.), the cycle is a read modify write cycle and data out will contain data read from the selected cell; if neither of the above sets of conditions is satisfied, the condition of the data out (at access time) is indeterminate.
 10. These parameters are referenced to $\overline{\text{UCAS}}$, $\overline{\text{LCAS}}$, leading edge in an early write cycle, and to $\overline{\text{WE}}$ leading edge in an $\overline{\text{OE}}$ control write cycle or a read modify write cycle.
 11. These parameters are determined by the falling edge of $\overline{\text{UCAS}}$ or $\overline{\text{LCAS}}$, whichever is earlier.
 12. These parameters are determined by the rising edge of $\overline{\text{UCAS}}$ or $\overline{\text{LCAS}}$, whichever is later.
 13. t_{CWL} should be satisfied by both $\overline{\text{UCAS}}$ or $\overline{\text{LCAS}}$.
 14. t_{CP} and t_{CPT} are determined by the time both $\overline{\text{UCAS}}$ or $\overline{\text{LCAS}}$ are high.

See ADDENDUM E for AC Timing Waveforms