MSM5260

80-DOT COMMON/SEGMENT DRIVER

GENERAL DESCRIPTION

The MSM5260 is a dot matrix common/segment LCD driver LSI which is fabricated using low power CMOS metal gate technology. This LSI consists of 80-bit shift register, 80-bit latch, 80-bit level shifter and 80-bit 4-level driver.

It converts display data, which is serially received from an LCD controller LSI, to parallel data, and outputs LCD driving waveform to LCD.

This LSI can drive a variety of LCD panels since the bias voltage can be optionally supplied from an external source.

FEATURES

- Supply voltage : 4.5 to 5.5V
- LCD driving voltage : 8 to 18V
- Applicable LCD duty : static and 1/32 to 1/64
- Bias voltage can be supplied externally
- Can be used either as common or segment driver
- Interface with MSM6255 LCD controller LSI
- Package options :
 - 100-pin plastic QFP (QFP100-P-1420-0.65-K) (Product name : MSM5260GS-K)
 - 100-pin plastic QFP (QFP100-P-1420-0.65-L) (Product name : MSM5260GS-L)
 - 100-pin plastic QFP (QFP100-P-1420-0.65-BK) (Product name : MSM5260GS-BK)

BLOCK DIAGRAM

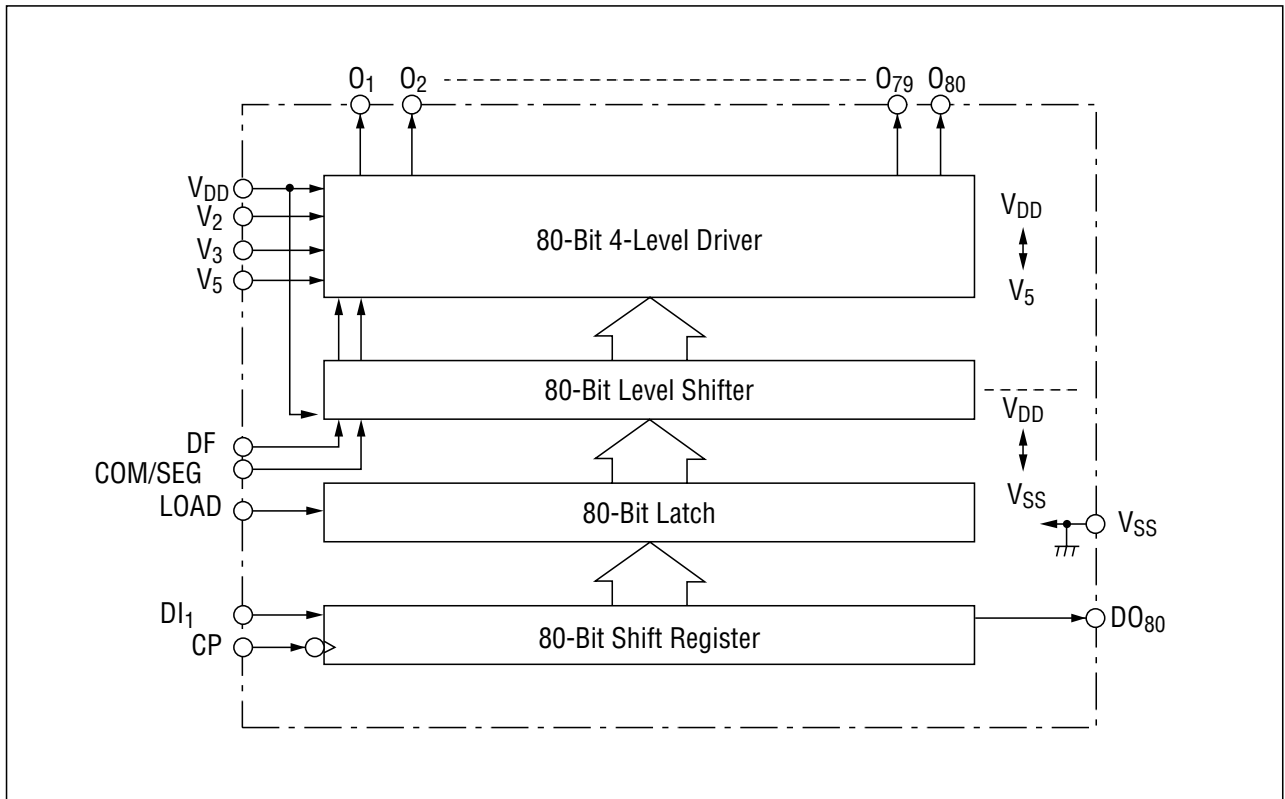

PIN CONFIGURATION (TOP VIEW)

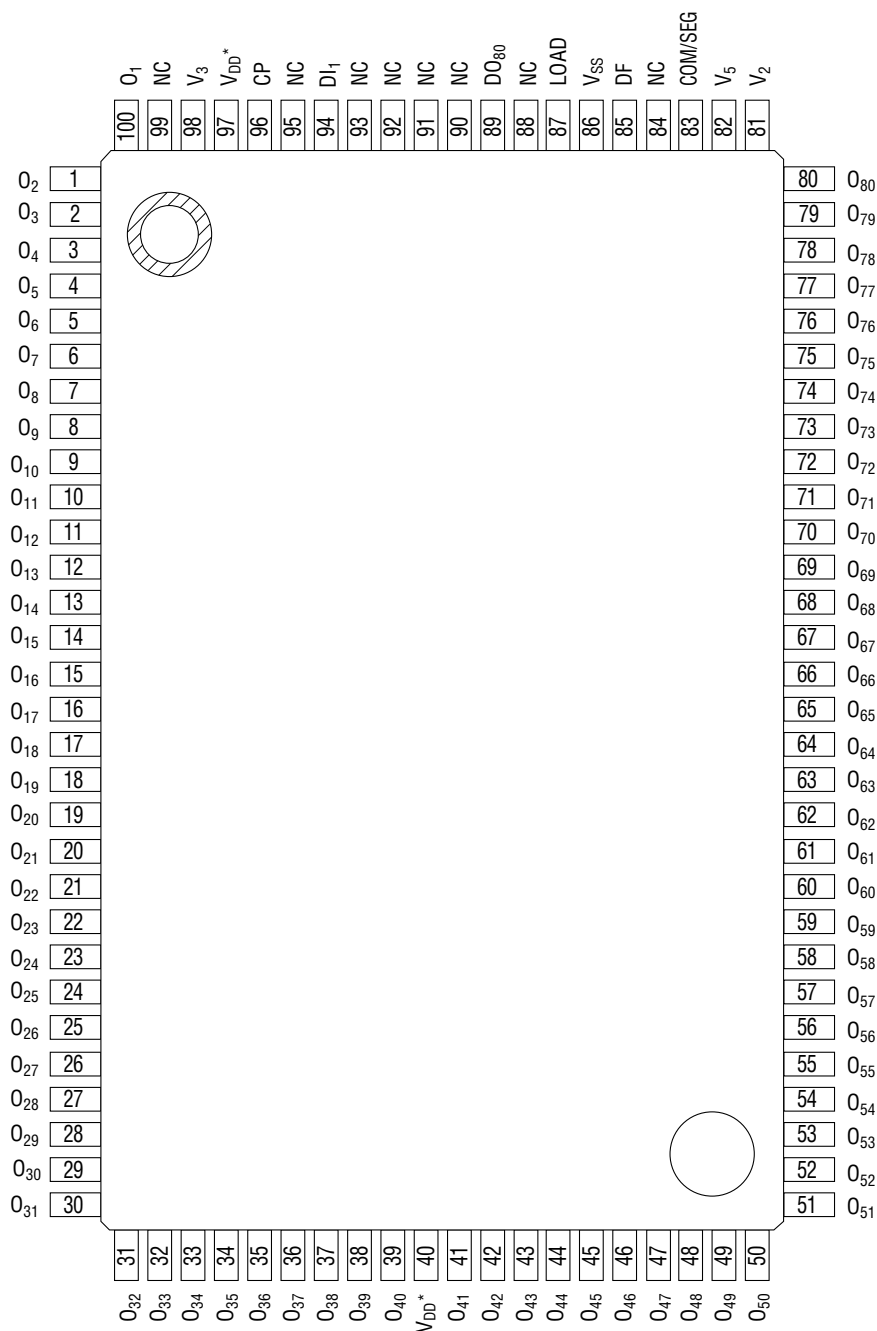

NC : No connection

100-Pin Plastic QFP (Type K)

*V_{DD} must be supplied to both pin 40 and pin 97.

ABSOLUTE MAXIMUM RATINGS

Parameter	Symbol	Condition	Rating	Unit
Supply Voltage (1)	V_{DD}	$T_a = 25^{\circ}\text{C}$	-0.3 to +6.0	V
Supply Voltage (2)	V_{LCD}	$T_a = 25^{\circ}\text{C}, V_{DD} - V_5$ *1	0 to 18	V
		$T_a = 25^{\circ}\text{C}, V_{DD} - V_5$ *1*2	0 to 20	V
Input Voltage	V_I	$T_a = 25^{\circ}\text{C}$	-0.3 to $V_{DD} + 0.3$	V
Storage Temperature	T_{STG}	—	-55 to +150	$^{\circ}\text{C}$

*1 $V_{DD} > V_2 > V_3 > V_5$

*2 When a series resistance of more than 47Ω is connected as shown below:

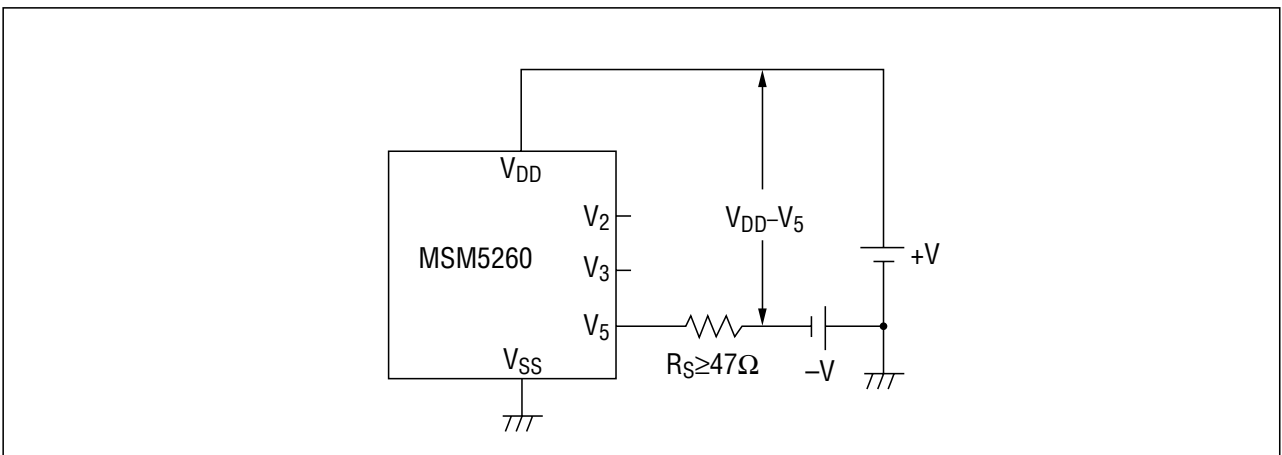

RECOMMENDED OPERATING CONDITIONS

Parameter	Symbol	Condition	Range	Unit
Supply Voltage (1)	V_{DD}	—	4.5 to 5.5	V
Supply Voltage (2)	V_{LCD}	$V_{DD} - V_5$ *1	8 to 16	V
		$V_{DD} - V_5$ *1*2	8 to 18	V
Operating Temperature	T_{Op}	—	-20 to +85	°C

*1 $V_{DD} > V_2 > V_3 > V_5$

*2 When a series resistance of more than 47Ω is connected as shown below:

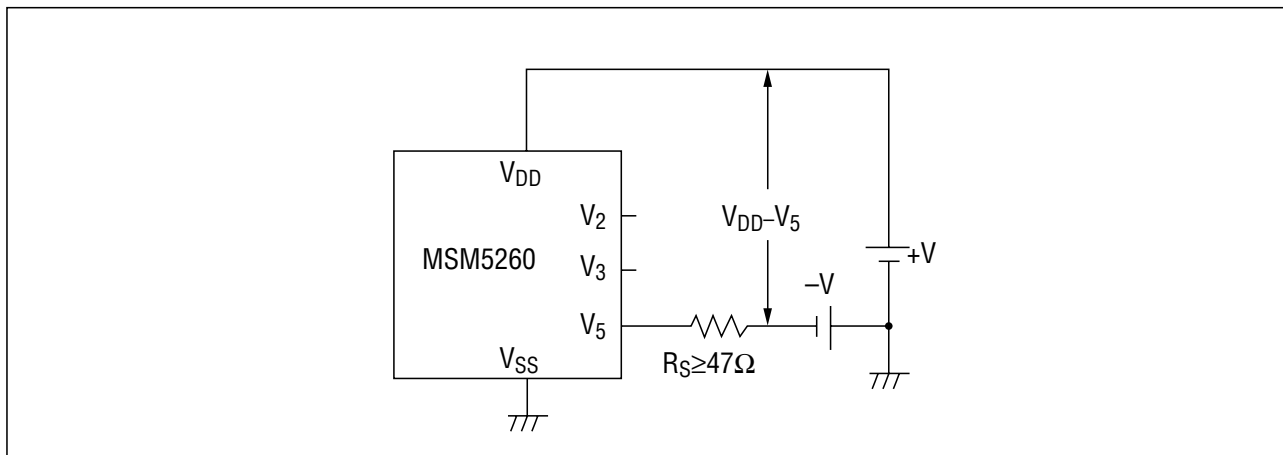

ELECTRICAL CHARACTERISTICS

DC Characteristics

($V_{DD} = 5V \pm 10\%$, $T_a = -20$ to $+85^\circ C$)

Parameter	Symbol	Condition	Min.	Typ.	Max.	Unit
"H" Input Voltage	V_{IH} *1		$0.8V_{DD}$	—	V_{DD}	V
"L" Input Voltage	V_{IL} *1		V_{SS}	—	$0.2V_{DD}$	V
"H" Input Current	I_{IH} *1	$V_{IH} = V_{DD}$	—	—	1	μA
"L" Input Current	I_{IL} *1	$V_{IL} = 0V$	—	—	-1	μA
"H" Output Voltage	V_{OH} *2	$I_o = -0.4mA$	$V_{DD} - 0.4$	—	—	V
"L" Output Voltage	V_{OL} *2	$I_o = 0.4mA$	—	—	0.4	V
ON Resistance	R_{ON} *4	$V_{DD} - V_5 = 10V$ $ V_N - V_O = 0.25V$ *3	—	1	2	kΩ
Supply Current	I_{DD}	CP = DC $V_{DD} - V_5 = 18V$, no load	—	—	100	μA

*1 Applied to LOAD, CP, DI₁, DF and COM/SEG

*2 Applied to DO₈₀

*3 $V_N = V_{DD}$ to V_5 , $V_2 = 8/9 (V_{DD} - V_5)$, $V_3 = 1/9 (V_{DD} - V_5)$

*4 Applied to O₁ to O₈₀

Switching Characteristics

($V_{DD} = 5V \pm 10\%$, $T_a = -20$ to $+85^\circ C$, $C_L = 15pF$)

Parameter	Symbol	Condition	Min.	Typ.	Max.	Unit
"H", "L" Propagation Delay Time	t_{pLH} t_{pHL}	—	—	—	250	ns
Clock Frequency	f_{CP}	Duty = 50%	—	—	3.3	MHz
Clock Pulse Width	$t_{W(CP)}$	—	125	—	—	ns
LOAD Pulse Width	$t_{W(L)}$	—	125	—	—	ns
Data Setup Time DI→CP	t_{SETUP}	—	50	—	—	ns
CP→LOAD Time	t_{CL}	—	250	—	—	ns
LOAD→CP Time	t_{LC}	—	0	—	—	ns
Data Hold Time DI→CP	t_{HOLD}	—	50	—	—	ns
CP Rise/Fall Time	$t_r(CP)$ $t_f(CP)$	—	—	—	50	ns
LOAD Rise/Fall Time	$t_r(L)$ $t_f(L)$	—	—	—	1	μs

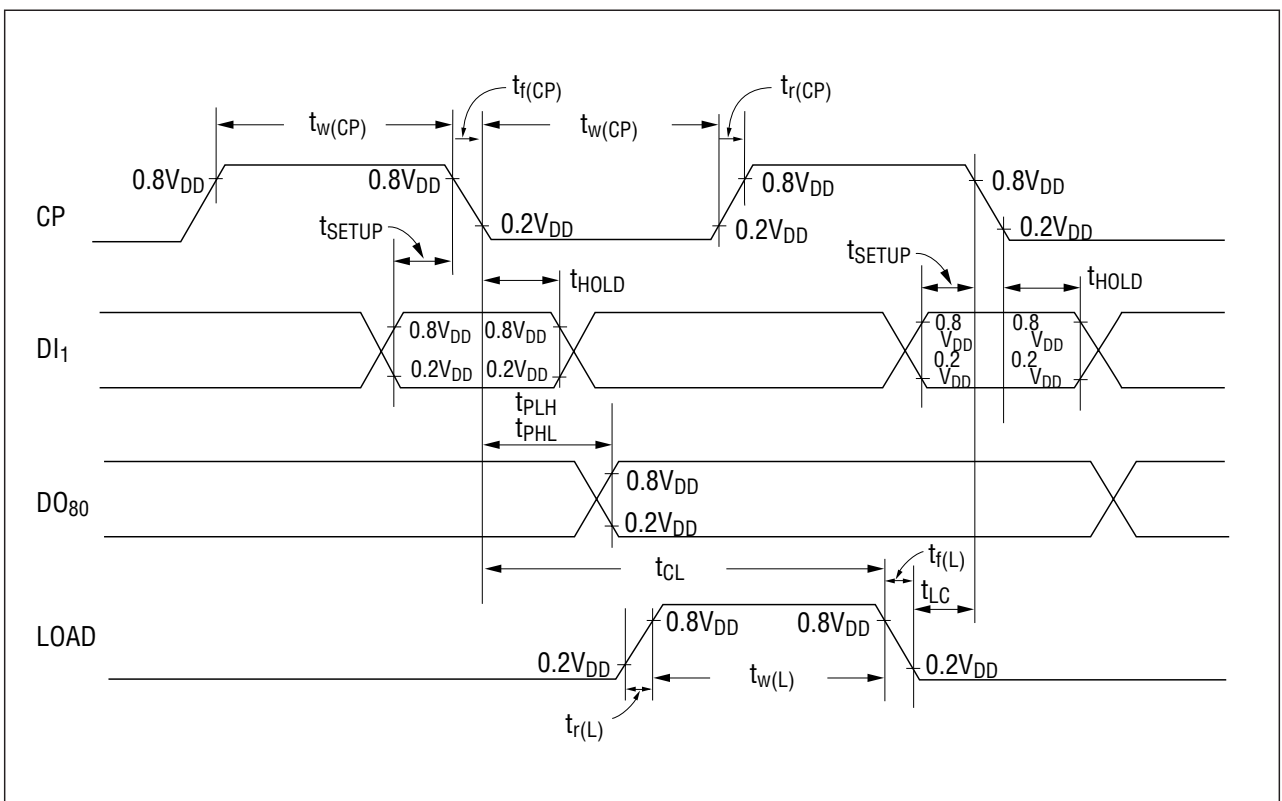

FUNCTIONAL DESCRIPTION

Pin Functional Description

- **DI₁**
The data input pin for the 80-bit shift register (between 1st to 80th bit). The display data is clocked in to this pin. (Positive logic)
- **CP**
Clock pulse input pin for 80-bit shift register. The data is shifted to the 80-bit shift register at the falling edge of the clock pulse. A data setup time (t_{SETUP}) and a data hold time (t_{HOLD}) are required between a DI₁ signal and a clock pulse.
Clock pulse rise time (t_r) and clock pulse fall time (t_f) should be a maximum of 50ns respectively.
- **DO₈₀**
The 80th bit output from the 80-bit shift register.
The data which is input from DI₁ is clocked out with the delay in the number of the bits of the shift register.
When extending the number of characters, this pin is used to connect to the next MSM5260 in cascade.
- **LOAD**
The signal for latching the shift register contents is input from this pin.
When LOAD pin is set at "H" level, the shift register contents are transferred to the 80-bit 4-level driver through the 80-bit level shifter.
When LOAD pin is set at "L" level, the last display output data (O₁ to O₈₀), which was transferred when LOAD pin was at "H" level, is held.
- **DF**
Synchronous signal input pin for alternate signal for LCD driving.

• **COM/SEG**

Selection signal input pin. MSM5260 is used either as common driver or segment driver according to input signal level at COM/SEG pin.

When this pin is set when at "H" level, MSM5260 is used as a common driver, while it is used as a segment driver when at "L" level.

The display driving data O₁ to O₈₀ are determined according to the combination of latched data and DF signal, as shown in Table 1 below.

Table 1

COM/SEG	Latched data level	DF	Driver data output level (O ₁ - O ₈₀)	Remarks
H	High (Select)	H	V _{DD}	Common driver
		L	V ₅	
	Low (Non-select)	H	V ₃	
		L	V ₂	
L	High (Select)	H	V ₅	Segment driver
		L	V _{DD}	
	Low (Non-select)	H	V ₃	
		L	V ₂	

When MSM5260 is used as a common driver, both LOAD pin and COM/SEG pin are to be connected to V_{DD}. In this case, a bias voltage of common side's non-select level is to be supplied to V₂ and V₃ pins.

• **V_{DD}, V_{SS}**

Supply voltage pins. V_{DD} should be 4.5 to 5.5V.

V_{SS} is a ground pin (V_{SS} = 0V)

• **V₂, V₃, V₅**

Bias supply voltage pins to drive the LCD. Use an external bias voltage supply for driving the LCD.

• **O₁ to O₈₀**

Display data output pins which correspond to each bit of the 80-bit latch.

One of V_{DD}, V₂, V₃ and V₅ is selected as a display driving voltage source according to the combination of latched data level and DF signal.

NOTES ON USE

Note the following when turning power on and off :

The LCD drivers of this IC requires a high voltage. For this reason, if a high voltage is applied to the LCD drivers with the logic power supply floating, excess current flows. This may damage the IC. Be sure to carry out the following power-on and power-off sequences :

When turning power on :

First V_{DD} ON, next V₅, V₃, V₂ ON. Or both ON at the same time.

When turning power off :

First V₅, V₃, V₂ OFF, next V_{DD} OFF. Or both OFF at the same time.

(Unit : mm)

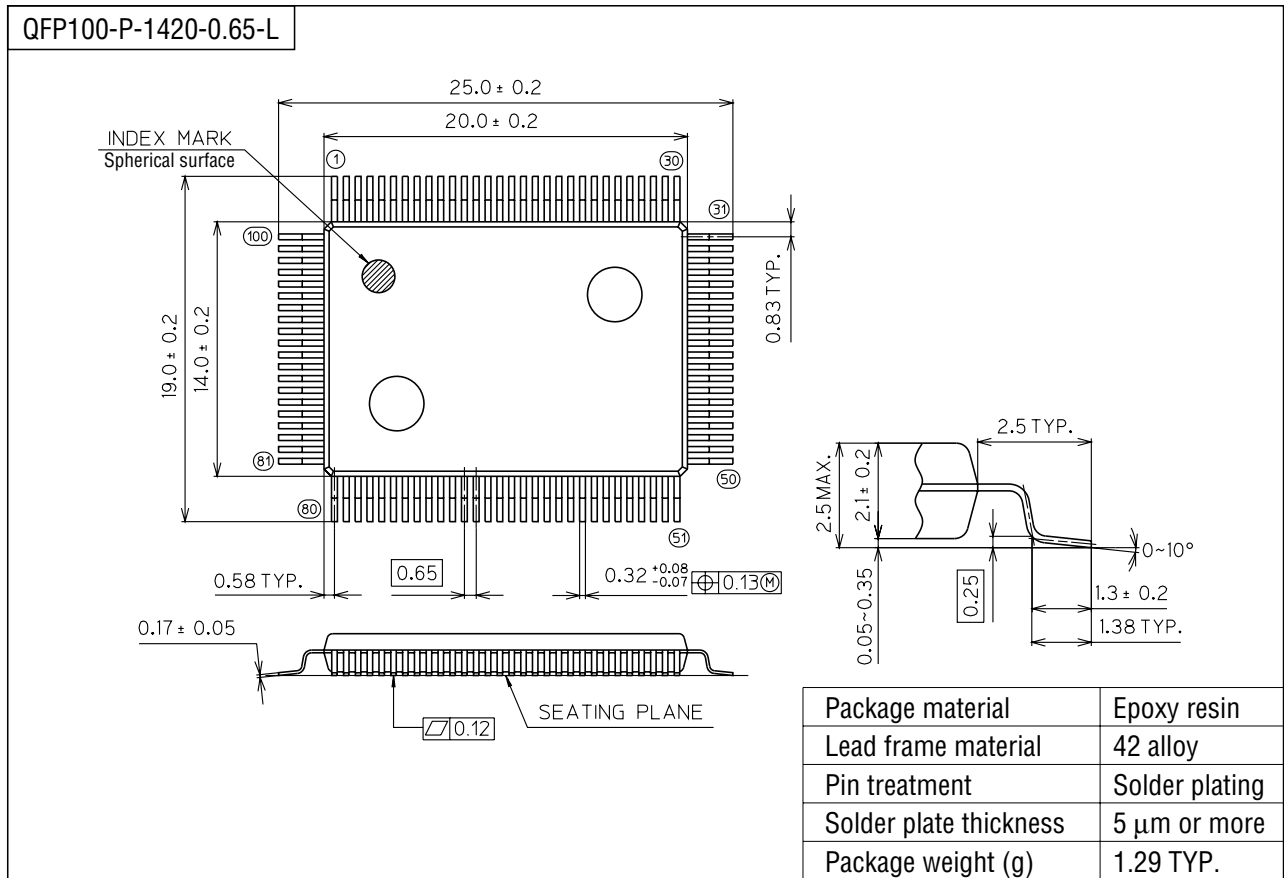

Notes for Mounting the Surface Mount Type Package

The SOP, QFP, TSOP, SOJ, QFJ (PLCC), SHP and BGA are surface mount type packages, which are very susceptible to heat in reflow mounting and humidity absorbed in storage. Therefore, before you perform reflow mounting, contact Oki's responsible sales person for the product name, package name, pin number, package code and desired mounting conditions (reflow method, temperature and times).

(Unit : mm)

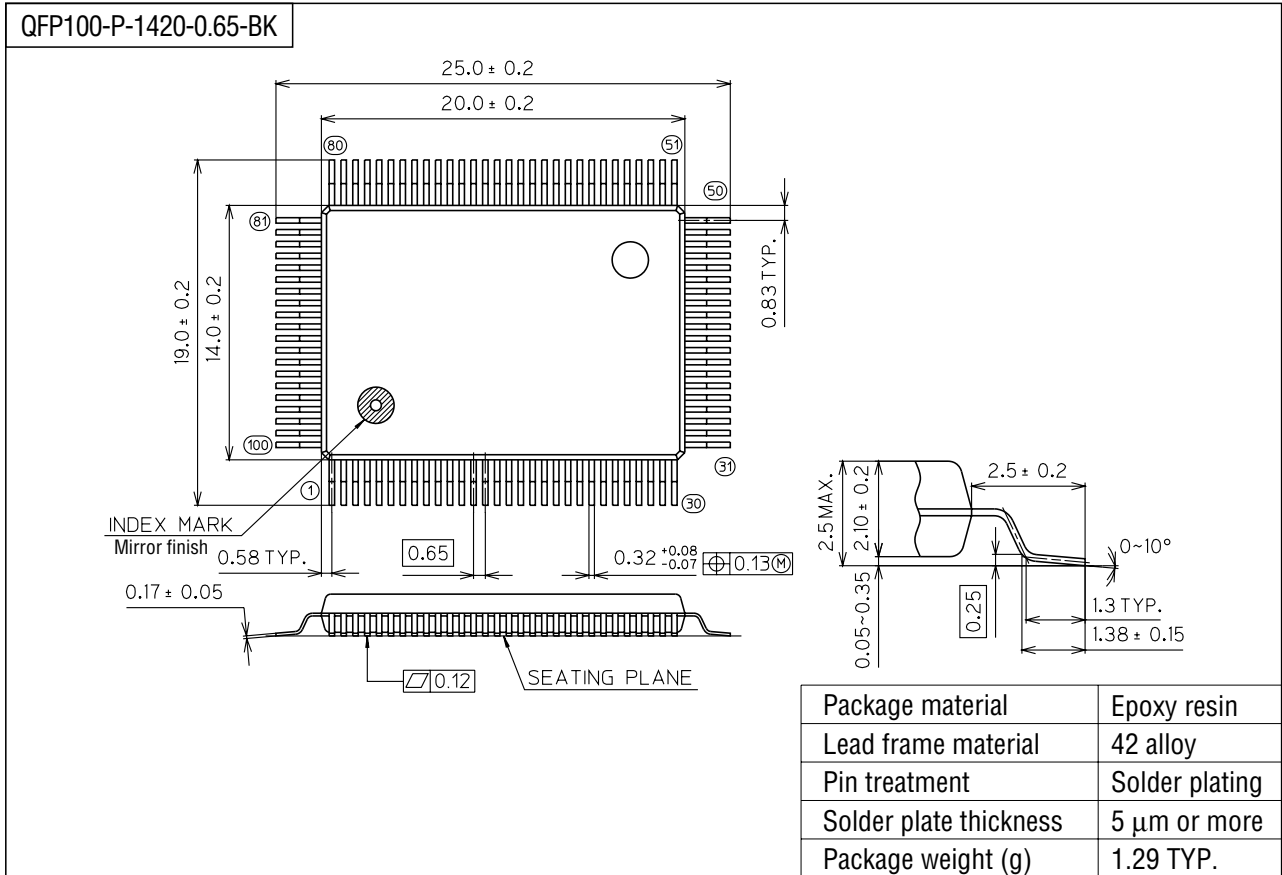

Notes for Mounting the Surface Mount Type Package

The SOP, QFP, TSOP, SOJ, QFJ (PLCC), SHP and BGA are surface mount type packages, which are very susceptible to heat in reflow mounting and humidity absorbed in storage. Therefore, before you perform reflow mounting, contact Oki's responsible sales person for the product name, package name, pin number, package code and desired mounting conditions (reflow method, temperature and times).