

# MSM64162

## 4-Bit Microcontroller with Built-in RC Oscillation Type A/D Converter and LCD Driver

### GENERAL DESCRIPTION

The MSM64162 is a low power 4-bit microcontroller that employs Oki's original CPU core nX-4/20.

The MSM64162 has 2-channel RC oscillation type A/D converter, LCD driver for up to 80 segments, and buzzer output port. It is best suited for applications such as low power, high precision thermometers and hygrometers.

### FEATURES

- Operating range
  - Operating frequencies : 32.768 kHz, 400 kHz
  - Operating voltage : 1.25 to 1.7 V (1.5 V spec.)  
2.0 to 3.5 V (3 V spec.)  
2.2 to 3.5 V (3 V spec., 1/2 duty)
  - Operating temperature : -40 to +85°C
- Memory space
  - Internal program memory : 2016 bytes
  - Internal data memory : 128 nibbles
- Minimum instruction execution time : 7.5  $\mu$ s @ 400 kHz  
91.6  $\mu$ s @ 32.768 kHz
- RC oscillation type A/D converter : 2 channels
- LCD driver : 24 outputs; duty ratio switchable by software
  - (1) At 1/4 duty and 1/3 bias : 80 segments (max)
  - (2) At 1/3 duty and 1/3 bias : 63 segments (max)
  - (3) At 1/2 duty and 1/2 bias : 44 segments (max)
- Buzzer driver : 1 output (4 output modes selectable)
- Capture circuit : 2 channels
- Watchdog timer
- Clock : 32.768 kHz crystal oscillator and 400 kHz RC oscillator (with an external resistor)
  - CPU clock : 32.768 kHz/400 kHz (switchable by software)
  - Time base clock : 32.768 kHz
- Power supply voltage : 1.5 V/3 V (selectable by mask option)
- I/O port
  - Input-output port : 2 ports  $\times$  4 bits
  - Input port : 1 port  $\times$  4 bits
  - Output port : 1 port  $\times$  4 bits  
(8 out of the 24 LCD driver outputs can be used as output-only ports by mask option.)
- Interrupt sources
  - External interrupt : 2 sources
  - Internal interrupt : 7 sources
- Battery check circuit : 1 (incorporated into the input-only port)

- Package options:

64-pin plastic QFP (QFP64-P-1420-1.00-BK) : (Product name : MSM64162-xxxGS-BK)

80-pin plastic QFP (QFP80-P-1420-0.80-BK) : (Product name : MSM64162-xxxGS-BK-F)

Chip : (Product name : MSM64162-xxx)

xxx indicates a code number.

**BLOCK DIAGRAM**

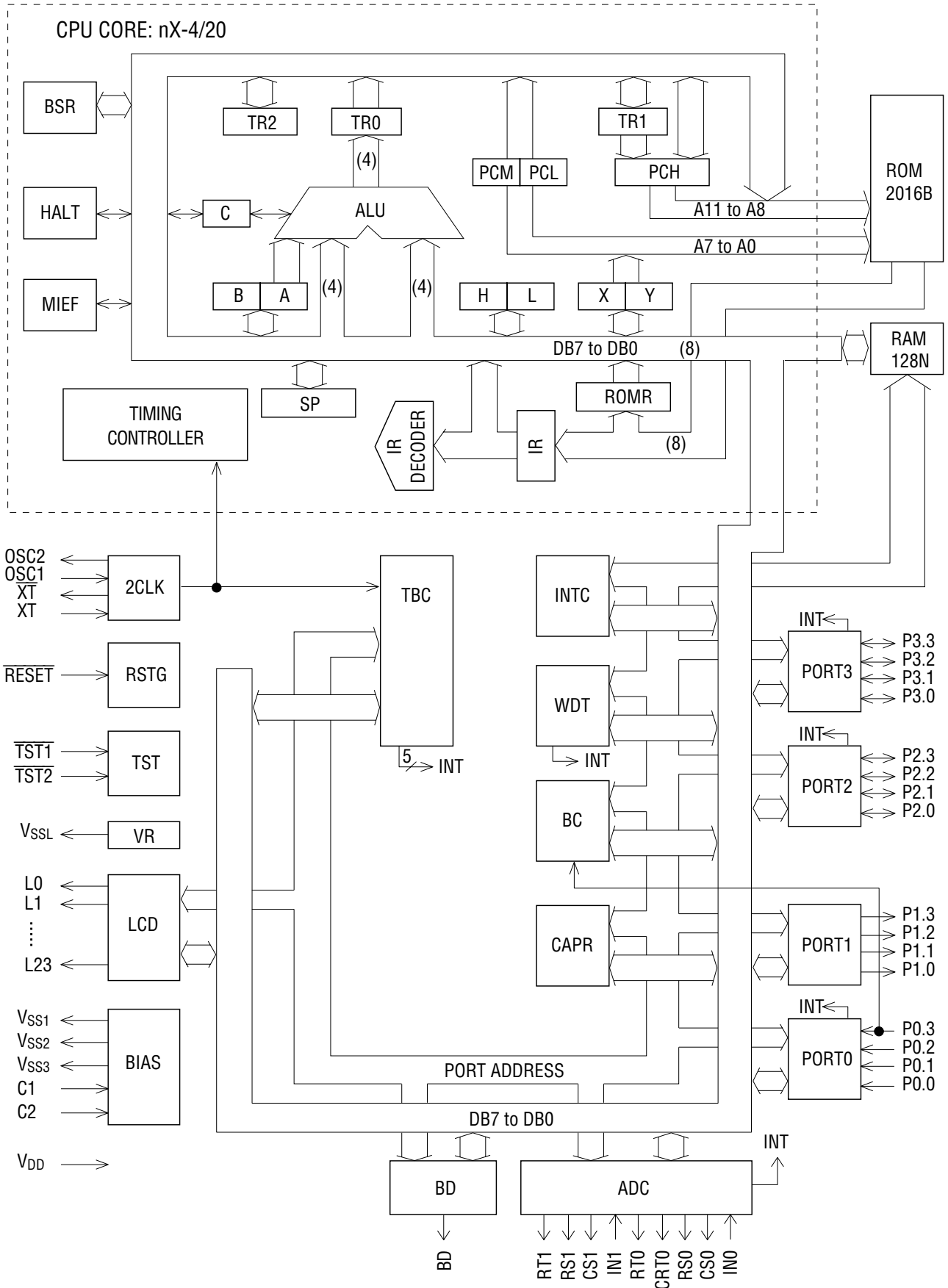

**PIN CONFIGURATION (TOP VIEW)**

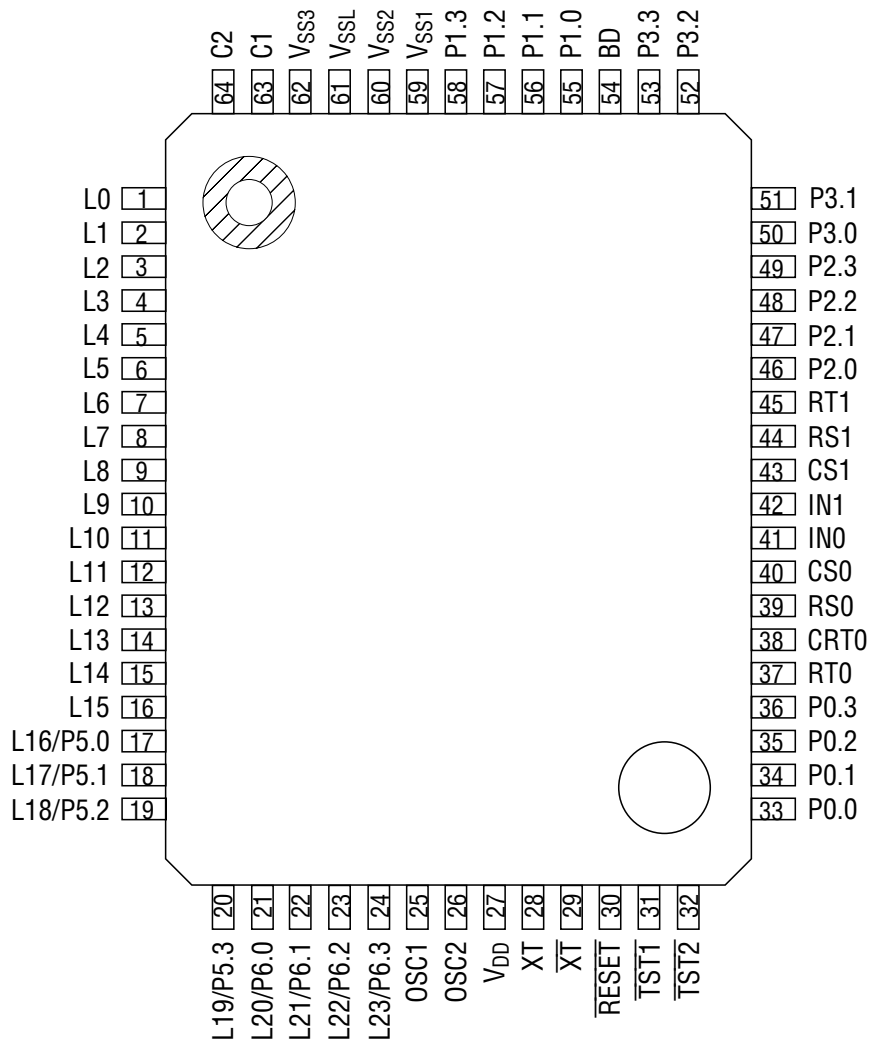

**64-Pin Plastic QFP**

**PIN CONFIGURATION (TOP VIEW) (continued)**

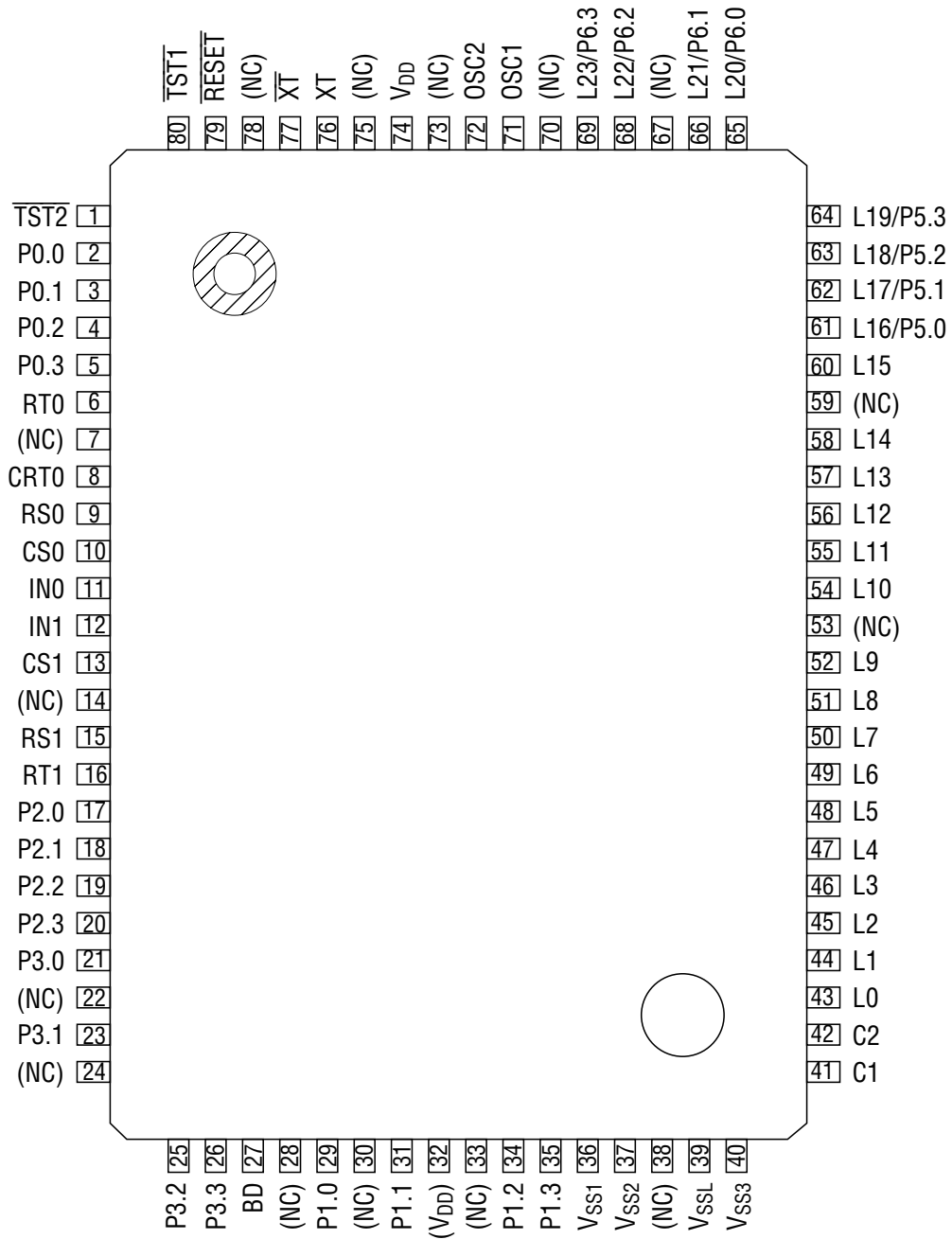

**80-Pin Plastic QFP**

- Notes: 1. Pins marked as (NC) are no-connection pins which are left open.  
 2.  $V_{DD}$  should be supplied from pin 74. Pin 32 is internally connected to  $V_{DD}$ .

## PAD CONFIGURATION

### Pad Layout

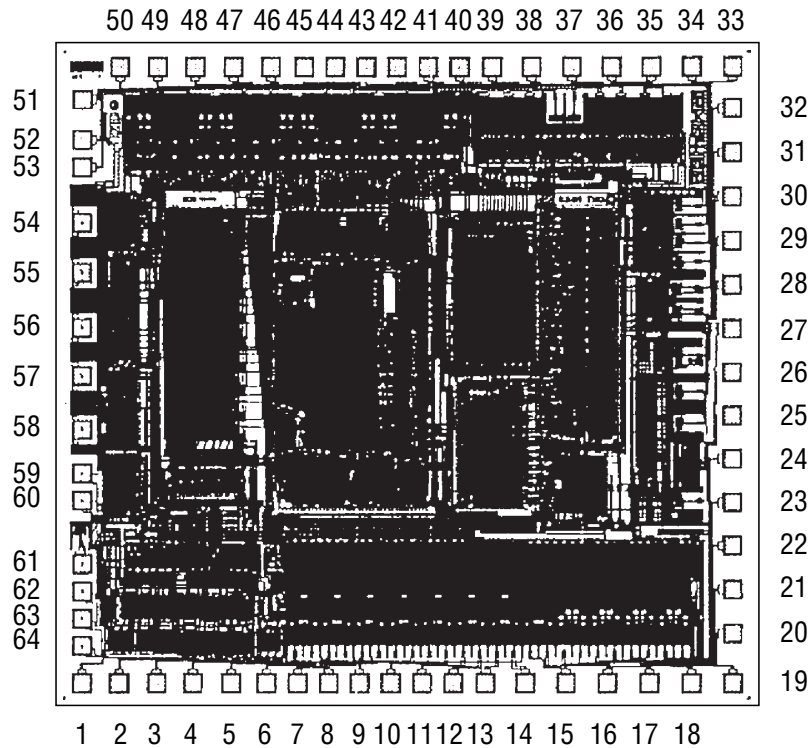

Chip Size	: 4.69 mm × 4.41 mm
Chip Thickness	: 350 μm (typ.)
Coordinate Origin	: Chip center
Pad Hole Size	: 110 μm × 110 μm
Pad Size	: 130 μm × 130 μm
Minimum Pad Pitch	: 180 μm

Note: The chip substrate voltage is  $V_{DD}$ .

## Pad Coordinates

Pad No.	Pad Name	X ( $\mu\text{m}$ )	Y ( $\mu\text{m}$ )	Pad No.	Pad Name	X ( $\mu\text{m}$ )	Y ( $\mu\text{m}$ )
1	L0	-2168	-2042	33	P0.0	2168	2042
2	L1	-1918	-2042	34	P0.1	1899	2042
3	L2	-1669	-2042	35	P0.2	1628	2042
4	L3	-1426	-2042	36	P0.3	1364	2042
5	L4	-1170	-2042	37	RT0	1100	2042
6	L5	-934	-2042	38	CRT0	829	2042
7	L6	-727	-2042	39	RS0	565	2042
8	L7	-519	-2042	40	CS0	349	2042
9	L8	-312	-2042	41	IN0	141	2042
10	L9	-104	-2042	42	IN1	-67	2042
11	L10	104	-2042	43	CS1	-274	2042
12	L11	311	-2042	44	RS1	-482	2042
13	L12	527	-2042	45	RT1	-689	2042
14	L13	791	-2042	46	P2.0	-911	2042
15	L14	1062	-2042	47	P2.1	-1160	2042
16	L15	1340	-2042	48	P2.2	-1416	2042
17	L16/P5.0	1618	-2042	49	P2.3	-1666	2042
18	L17/P5.1	1897	-2042	50	P3.0	-1916	2042
19	L18/P5.2	2168	-2042	51	P3.1	-2168	1829
20	L19/P5.3	2168	-1714	52	P3.2	-2168	1563
21	L20/P6.0	2168	-1424	53	P3.3	-2168	1382
22	L21/P6.1	2168	-1134	54	BD	-2168	1017
23	L22/P6.2	2168	-844	55	P1.0	-2168	688
24	L23/P6.3	2168	-554	56	P1.1	-2168	328
25	OSC1	2168	-264	57	P1.2	-2168	6
26	OSC2	2168	26	58	P1.3	-2168	-353
27	V <sub>DD</sub>	2168	316	59	V <sub>SS1</sub>	-2168	-645
28	XT	2168	606	60	V <sub>SS2</sub>	-2168	-826
29	$\overline{\text{XT}}$	2168	896	61	V <sub>SSL</sub>	-2168	-1254
30	$\overline{\text{RESET}}$	2168	1186	62	V <sub>SS3</sub>	-2168	-1435
31	$\overline{\text{TST1}}$	2168	1476	63	C1	-2168	-1616
32	$\overline{\text{TST2}}$	2168	1766	64	C2	-2168	-1796

## PIN DESCRIPTIONS

The following tables describe the pin basic functions and secondary functions of the MSM64162. For pin, "64QFP" and "80QFP" denote 64-pin flat package and 80-pin flat package respectively.

### Basic Functions

Function	Symbol	Pin		Pad	Type	Description
		64QFP	80QFP			
Power Supply	V <sub>DD</sub>	27	74	27	—	0 V power supply
	V <sub>SS1</sub>	59	36	59	—	Negative power supply (for 1.5 V spec.) Bias output for driving LCD (–1.5 V) (for 3.0 V spec.)
	V <sub>SS2</sub>	60	37	60	—	Negative power supply (for 3.0 V spec.) Bias output for driving LCD (–3.0 V) (for 1.5 V spec.)
	V <sub>SS3</sub>	62	40	62	—	Bias output for driving LCD (–4.5 V).
	C1	63	41	63	—	Pins for connecting a capacitor for generating LCD driving bias
	C2	64	42	64	—	
	V <sub>SSL</sub>	61	39	61	—	Negative power supply for internal logic (An internally generated constant voltage is present at this pin.)
Oscillation	XT	28	76	28	I	Low-speed clock oscillation input and output pins: Connect to a crystal (32.768 kHz).
	$\overline{XT}$	29	77	29	0	
	OSC1	25	71	25	I	High-speed clock oscillation input and output pins: Connect to an external resistor for oscillation (R <sub>OS</sub> ).
	OSC2	26	72	26	0	
Test	$\overline{TST1}$	31	80	31	I	Input pins for testing.
	$\overline{TST2}$	32	1	32	I	A pull-up resistor is internally connected to these pins.
Reset	$\overline{RESET}$	30	79	30	I	System reset input pin. Setting this pin to "L" level puts this device into a reset state. Then, setting this pin to "H" level starts executing an instruction from address 000H. A pull-up resistor is internally connected to this pin.



## Basic Functions (continued)

Function	Symbol	Pin		Pad	Type	Description
		64QFP	80QFP			
Ports	P0.0	33	2	33	I	4-bit input port (P0): Selectable as pull-up resistor input, pull-down resistor input, or high impedance input by the port 01 control register (P01CON). As secondary functions, P0.0 to P0.3 are assigned external interrupt functions, P0.0 and P0.1 are assigned a capture trigger function, and P0.3 is assigned an analog comparator input for battery check.
	P0.1	34	3	34	I	
	P0.2	35	4	35	I	
	P0.3	36	5	36	I	
	P1.0	55	29	55	O	4-bit output port (P1): Selectable as NMOS open drain output or CMOS output by the port 01 control register (P01CON). P1.0 is a high current drive output port.
	P1.1	56	31	56	O	
	P1.2	57	34	57	O	
	P1.3	58	35	58	O	
	P2.0	46	17	46	I/O	4-bit input-output port (P2): Following can be specified for each bit by the port 2 control registers 0 to 3 (P20CON to P23CON): (1) input or output, (2) pull-up/pull-down resistor input or high impedance input, and (3) NMOS open drain output or CMOS output. As secondary functions, P2.0 to P2.3 are assigned external interrupt functions.
	P2.1	47	18	47	I/O	
	P2.2	48	19	48	I/O	
	P2.3	49	20	49	I/O	
	P3.0	50	21	50	I/O	4-bit input-output port (P3): Following can be specified for each bit by the port 3 control registers 0 to 3 (P30CON to P33CON): (1) input or output, (2) pull-up/pull-down resistor input or high impedance input, and (3) NMOS open drain output or CMOS output. As secondary functions, P3.0 to P3.3 are assigned external interrupt functions, P3.3 is assigned a function that monitors the RC oscillation clock for A/D converter.
	P3.1	51	23	51	I/O	
	P3.2	52	25	52	I/O	
	P3.3/MON	53	26	53	I/O	
Buzzer	BD	54	27	54	O	Output pin for the buzzer driver
A/D Converter	RT0	37	6	37	O	Resistance temperature sensor connection pin (for channel 0)
	CRT0	38	8	38	O	Resistance/capacitance temperature sensor connection pin (for channel 0)
	RS0	39	9	39	O	Reference resistor connection pin (for channel 0)
	CS0	40	10	40	O	Reference capacitor connection pin (for channel 0)
	IN0	41	11	41	I	Input pin for RC oscillator circuit (for channel 0)
	RT1	45	16	45	O	Resistance temperature sensor connection pin (for channel 1)
	RS1	44	15	44	O	Reference resistor connection pin (for channel 1)
	CS1	43	13	43	O	Reference capacitor connection pin (for channel 1)
	IN1	42	12	42	I	Input pin for RC oscillator circuit (for channel 1)

Basic Functions (continued)

Function	Symbol	Pin		Pad	Type	Description
		64QFP	80QFP			
LCD Driver	L0	1	43	1	0	LCD segment and common signals output pins.
	L1	2	44	2	0	
	L2	3	45	3	0	
	L3	4	46	4	0	
	L4	5	47	5	0	
	L5	6	48	6	0	
	L6	7	49	7	0	
	L7	8	50	8	0	
	L8	9	51	9	0	
	L9	10	52	10	0	
	L10	11	54	11	0	
	L11	12	55	12	0	
	L12	13	56	13	0	
	L13	14	57	14	0	
	L14	15	58	15	0	
	L15	16	60	16	0	
	L16/P5.0	17	61	17	0	LCD segment and common signals output pins. Functions as output ports by mask option.
	L17/P5.1	18	62	18	0	
	L18/P5.2	19	63	19	0	
	L19/P5.3	20	64	20	0	
	L20/P6.0	21	65	21	0	
	L21/P6.1	22	66	22	0	
	L22/P6.2	23	68	23	0	
	L23/P6.3	24	69	24	0	

**Secondary Functions**

Function	Symbol	Pin		Pad	Type	Description
		64QFP	80QFP			
External Interrupt	P0.0	33	2	33	I	Secondary functions of P0.0 to P0.3: Level-triggered external interrupt input pins. The change of input signal level causes an interrupt to occur.
	P0.1	34	3	34		
	P0.2	35	4	35		
	P0.3	36	5	36		
	P2.0	46	17	46	I	Secondary functions of P2.0 to P2.3 and P3.0 to P3.3: Level-triggered external interrupt input pins. The change of input signal level causes an interrupt to occur.
	P2.1	47	18	47		
	P2.2	48	19	48		
	P2.3	49	20	49		
	P3.0	50	21	50		
	P3.1	51	23	51		
	P3.2	52	25	52		
	P3.3	53	26	53		
Capture Trigger	P0.0	33	2	33	I	Secondary functions of P0.0 and P0.1: Capture circuit trigger input pins.
	P0.1	34	3	34		
RC Oscillation Monitor	P3.3	53	26	53	0	Secondary function of P3.3: Monitor output pin for an RC oscillation clock for A/D converter and a 400 kHz RC oscillation clock for the system clock.
Battery Check	P0.3	36	5	36	I	Secondary function of P0.3: Analog comparator input pin for battery check.

## MEMORY MAPS

### Program Memory

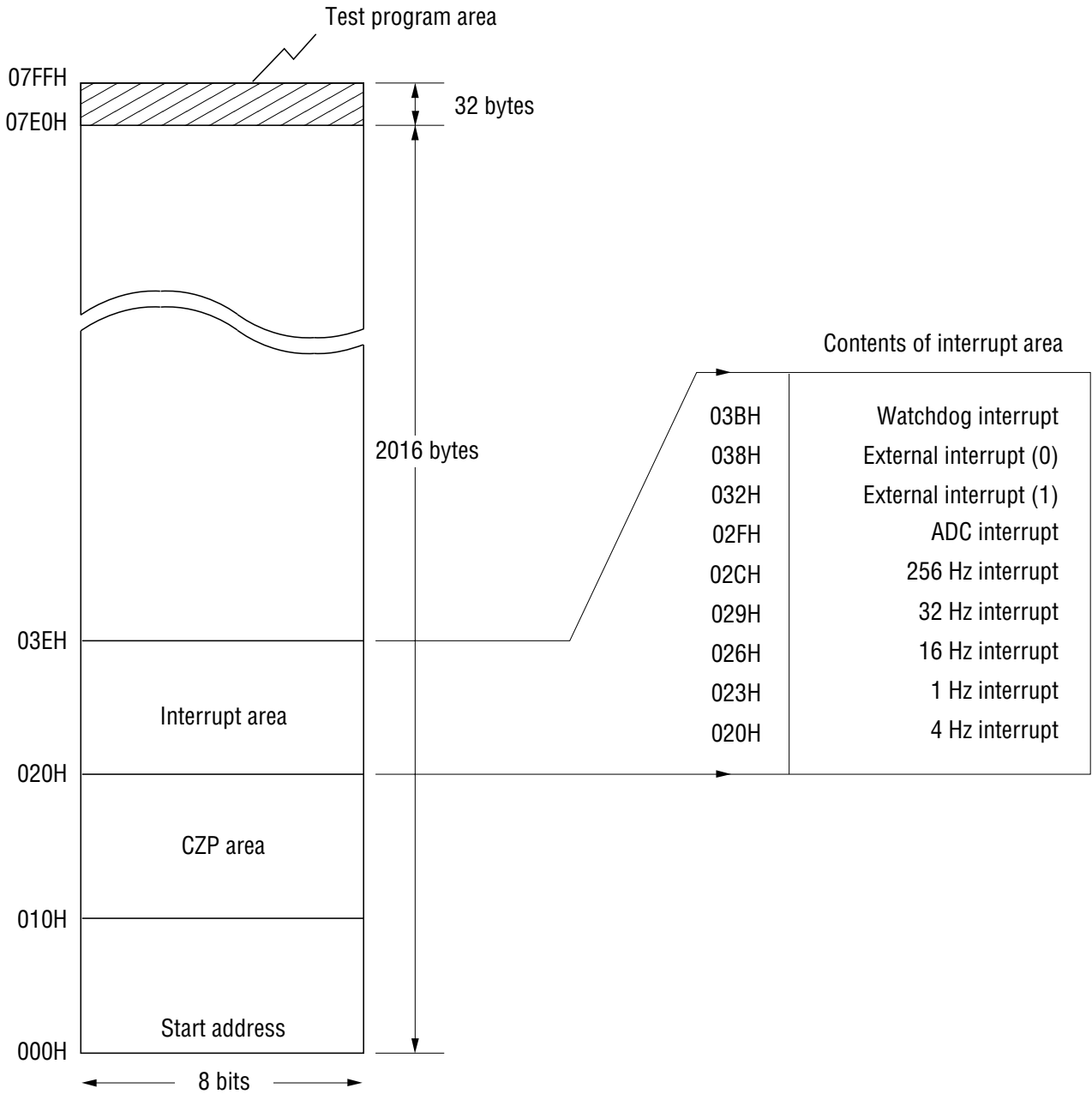

**Program Memory Map**

Address 000H is the instruction execution start address by the system reset.

The CZP area from address 010H to address 01FH is the start address for the CZP subroutine of 1-byte call instruction.

The start address of interrupt subroutine is assigned to the interrupt address from address 020H to 03DH.

The user area has 2016 bytes of address 000H to address 07DFH. No program can be stored in the test program area.

**Data Memory**

The data memory area consists of 8 banks and each bank has 256 nibbles (256 × 4 bits). The data RAM is assigned to BANK 7 and peripheral ports are assigned to BANK 0.

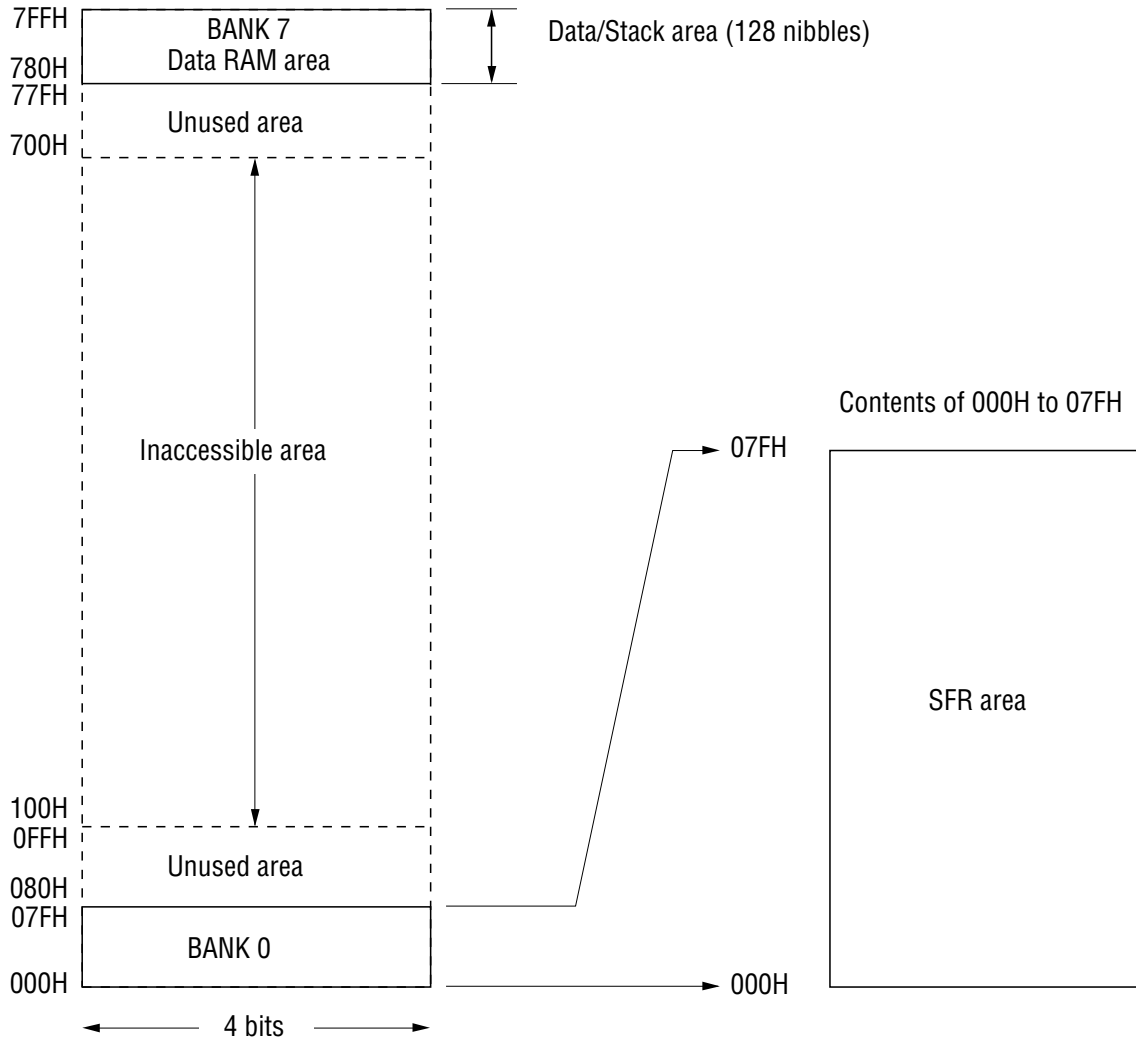

**Data Memory Map**

The data RAM area (128 nibbles) is shared by the stack area. The stack is a memory starting from address 7FFH toward the low-order addresses where 4 nibbles are used by Subroutine Call Instruction and 8 nibbles are used by an interrupt.

The addresses 080H to 0FFH of BANK 0 and the addresses 700H to 77FH of BANK 7 are not assigned as the data memory, so access to these addresses has no effect. Moreover, it is impossible to access BANK 1 to BANK 6.

**ABSOLUTE MAXIMUM RATINGS (1.5 V Spec.)**(V<sub>DD</sub> = 0 V)

Parameter	Symbol	Condition	Rating	Unit
Power Supply Voltage 1	V <sub>SS1</sub>	Ta = 25°C	-2.0 to +0.3	V
Power Supply Voltage 2	V <sub>SS2</sub>	Ta = 25°C	-4.0 to +0.3	V
Power Supply Voltage 3	V <sub>SS3</sub>	Ta = 25°C	-5.5 to +0.3	V
Power Supply Voltage 4	V <sub>SSL</sub>	Ta = 25°C	-2.0 to +0.3	V
Input Voltage 1	V <sub>IN1</sub>	V <sub>SS1</sub> Input, Ta = 25°C	V <sub>SS1</sub> - 0.3 to +0.3	V
Input Voltage 2	V <sub>IN2</sub>	V <sub>SSL</sub> Input, Ta = 25°C	V <sub>SSL</sub> - 0.3 to +0.3	V
Output Voltage 1	V <sub>OUT1</sub>	V <sub>SS1</sub> Output, Ta = 25°C	V <sub>SS1</sub> - 0.3 to +0.3	V
Output Voltage 2	V <sub>OUT2</sub>	V <sub>SS2</sub> Output, Ta = 25°C	V <sub>SS2</sub> - 0.3 to +0.3	V
Output Voltage 3	V <sub>OUT3</sub>	V <sub>SS3</sub> Output, Ta = 25°C	V <sub>SS3</sub> - 0.3 to +0.3	V
Output Voltage 4	V <sub>OUT4</sub>	V <sub>SSL</sub> Output, Ta = 25°C	V <sub>SSL</sub> - 0.3 to +0.3	V
Storage Temperature	T <sub>STG</sub>	—	-55 to +150	°C

**RECOMMENDED OPERATING CONDITIONS (1.5 V Spec.)**(V<sub>DD</sub> = 0 V)

Parameter	Symbol	Condition	Range	Unit
Operating Temperature	T <sub>op</sub>	—	-40 to +85	°C
Operating Voltage	V <sub>SS1</sub>	—	-1.7 to -1.25	V
External 400 kHz RC Oscillator Resistance	R <sub>OS</sub>	—	250 to 500	kΩ
Crystal Oscillation Frequency	f <sub>XT</sub>	—	30 to 35	kHz

**ELECTRICAL CHARACTERISTICS (1.5 V Spec.)****DC Characteristics**(V<sub>DD</sub> = 0 V, V<sub>SS1</sub> = -1.5 V, T<sub>a</sub> = -40 to +85°C unless otherwise specified)

Parameter	Symbol	Condition	Min.	Typ.	Max.	Unit	Measuring Circuit
V <sub>SS2</sub> Voltage	V <sub>SS2</sub>	C <sub>a</sub> , C <sub>b</sub> , C <sub>12</sub> = 0.1 μF +100% -50%	-3.2	-3.0	-2.8	V	1
V <sub>SS3</sub> Voltage	V <sub>SS3</sub>	C <sub>a</sub> , C <sub>b</sub> , C <sub>12</sub> = 0.1 μF +100% -50%	-4.7	-4.5	-4.3	V	
V <sub>SSL</sub> Voltage	V <sub>SSL</sub>	—	-1.5	-1.3	-0.6	V	
Crystal Oscillation Start Voltage	V <sub>STA</sub>	Oscillation start time: within 5 seconds	—	—	-1.45	V	
Crystal Oscillation Hold Voltage	V <sub>HOLD</sub>	—	—	—	-1.25	V	
Crystal Oscillation Stop Detection Time	T <sub>STOP</sub>	—	0.1	—	1000	ms	
Internal Crystal Oscillator Capacitance	C <sub>G</sub>	—	10	15	20	pF	
External Crystal Oscillator Capacitance	C <sub>GEX</sub>	When external C <sub>G</sub> used	10	—	30	pF	
Internal Crystal Oscillator Capacitance	C <sub>D</sub>	—	10	15	20	pF	
Internal 400k RC Oscillator Capacitance	C <sub>OS</sub>	—	8	12	16	pF	
400k RC Oscillation Frequency	f <sub>OSC</sub>	External resistor R <sub>OS</sub> = 300 kΩ V <sub>SS1</sub> = -1.25 to -1.7 V	80	220	350	kHz	
POR Generation Voltage	V <sub>POR1</sub>	When V <sub>SS1</sub> is between V <sub>POR1</sub> and -1.5 V	-0.4	—	0	V	
POR Non-generation Voltage	V <sub>POR2</sub>	No POR when V <sub>SS1</sub> is between V <sub>POR2</sub> and -1.5 V	-1.5	—	-1.2	V	
Battery Check Reference Voltage	V <sub>RB</sub>	T <sub>a</sub> = 25°C	-0.73	-0.63	-0.53	V	2
V <sub>RB</sub> Temperature Variation	ΔV <sub>RB</sub>	—	—	-2.0	—	mV/°C	

Notes: 1. "POR" denotes Power On Reset.

2. "T<sub>STOP</sub>" indicates that if the crystal oscillator stops over the value of T<sub>STOP</sub>, the system reset occurs.

**DC Characteristics (continued)**

( $V_{DD} = 0\text{ V}$ ,  $V_{SS1} = -1.5\text{ V}$ ,  $T_a = -40\text{ to }+85^\circ\text{C}$  unless otherwise specified)

Parameter	Symbol	Condition	Min.	Typ.	Max.	Unit	Measuring Circuit	
Supply Current 1	$I_{DD1}$	CPU in halt state (400k RC oscillation halt)	$T_a = -40\text{ to }+40^\circ\text{C}$	—	2	5	$\mu\text{A}$	
			$T_a = +40\text{ to }+85^\circ\text{C}$	—	2	30	$\mu\text{A}$	
Supply Current 2	$I_{DD2}$	CPU in operating state (400k RC oscillation halt)	$T_a = -40\text{ to }+40^\circ\text{C}$	—	5	15	$\mu\text{A}$	
			$T_a = +40\text{ to }+85^\circ\text{C}$	—	5	40	$\mu\text{A}$	
Supply Current 3	$I_{DD3}$	CPU in operating state (400k RC oscillation in operation) $R_{OS} = 300\text{ k}\Omega$	—	40	80	$\mu\text{A}$	1	
Supply Current 4	$I_{DD4}$	CPU in halt state (400k RC oscillation halt), RC oscillator for A/D converter is in operating state	$RT0 = 10\text{ k}\Omega$	—	150	230		$\mu\text{A}$
			$RT0 = 2\text{ k}\Omega$	—	600	900		$\mu\text{A}$
Supply Current 5	$I_{DD5}$	Battery check circuit in operating state, CPU in operating state (400k RC oscillation halt)	—	25	125	$\mu\text{A}$		



DC Characteristics (continued)

( $V_{DD} = 0\text{ V}$ ,  $V_{SS1} = V_{SSL} = -1.5\text{ V}$ ,  $V_{SS2} = -3.0\text{ V}$ ,  $V_{SS3} = -4.5\text{ V}$ ,  
 $T_a = -40\text{ to }+85^\circ\text{C}$  unless otherwise specified)

Parameter (Pin Name)	Symbol	Condition	Min.	Typ.	Max.	Unit	Measuring Circuit
Output Current 1 (P1.0)	$I_{OH1}$	$V_{OH1} = -0.5\text{ V}$	-2.1	-0.7	-0.2	mA	2
	$I_{OL1}$	$V_{OL1} = V_{SS1} + 0.5\text{ V}$	1.0	3.0	9.0	mA	
Output Current 2 (P1.1 to P1.3) (P2.0 to P2.3) (P3.0 to P3.3)	$I_{OH2}$	$V_{OH2} = -0.5\text{ V}$	-2.1	-0.7	-0.2	mA	
	$I_{OL2}$	$V_{OL2} = V_{SS1} + 0.5\text{ V}$	0.2	0.7	2.1	mA	
Output Current 3 (BD)	$I_{OH3}$	$V_{OH3} = -0.7\text{ V}$	-1.8	-0.6	-0.2	mA	
	$I_{OL3}$	$V_{OL3} = V_{SS1} + 0.7\text{ V}$	0.2	0.6	1.8	mA	
Output Current 4 (RT0, RT1, RS0, RS1, CRT0, CS0, CS1)	$I_{OH4}$	$V_{OH4} = -0.1\text{ V}$	-1.1	-0.6	-0.3	mA	
	$I_{OL4}$	$V_{OL4} = V_{SS1} + 0.1\text{ V}$	0.3	0.6	1.1	mA	
Output Current 5 (When L16 to L23 are configured as output ports)	$I_{OH5}$	$V_{OH5} = -0.5\text{ V}$	-1.5	-0.5	-0.1	mA	
	$I_{OL5}$	$V_{OL5} = V_{SS1} + 0.5\text{ V}$	0.1	0.5	1.5	mA	
Output Current 6 (OSC2)	$I_{OH6}$	$V_{OH6} = -0.5\text{ V}$	-2.1	-0.7	-0.2	mA	
	$I_{OL6}$	$V_{OL6} = V_{SS1} + 0.5\text{ V}$	0.2	0.7	2.1	mA	
Output Current 7 (L0 to L23)	$I_{OH7}$	$V_{OH7} = -0.2\text{ V}$ ( $V_{DD}$ level)	—	—	-4.0	$\mu\text{A}$	
	$I_{OMH7}$	$V_{OMH7} = V_{SS1} + 0.2\text{ V}$ ( $V_{SS1}$ level)	4.0	—	—	$\mu\text{A}$	
	$I_{OMH7S}$	$V_{OMH7S} = V_{SS1} - 0.2\text{ V}$ ( $V_{SS1}$ level)	—	—	-4.0	$\mu\text{A}$	
	$I_{OML7}$	$V_{OML7} = V_{SS2} + 0.2\text{ V}$ ( $V_{SS2}$ level)	4.0	—	—	$\mu\text{A}$	
	$I_{OML7S}$	$V_{OML7S} = V_{SS2} - 0.2\text{ V}$ ( $V_{SS2}$ level)	—	—	-4.0	$\mu\text{A}$	
	$I_{OL7}$	$V_{OL7} = V_{SS3} + 0.2\text{ V}$ ( $V_{SS3}$ level)	4.0	—	—	$\mu\text{A}$	
Output Leakage Current (P1.0 to P1.3) (P2.0 to P2.3) (P3.0 to P3.3) (RT0, RT1, RS0, RS1, CRT0, CS0, CS1)	$I_{OOH}$	$V_{OH} = V_{DD}$	—	—	0.3	$\mu\text{A}$	
	$I_{OOL}$	$V_{OL} = V_{SS1}$	-0.3	—	—	$\mu\text{A}$	

DC Characteristics (continued)

( $V_{DD} = 0\text{ V}$ ,  $V_{SS1} = V_{SSL} = -1.5\text{ V}$ ,  $V_{SS2} = -3.0\text{ V}$ ,  $V_{SS3} = -4.5\text{ V}$ ,  
 $T_a = -40\text{ to }+85^\circ\text{C}$  unless otherwise specified)

Parameter (Pin Name)	Symbol	Condition	Min.	Typ.	Max.	Unit	Measuring Circuit
Input Current 1 (P0.0 to P0.3) (P2.0 to P2.3) (P3.0 to P3.3)	$I_{IH1}$	$V_{IH1} = V_{DD}$ (when pulled down)	5	18	60	$\mu\text{A}$	3
	$I_{IL1}$	$V_{IL1} = V_{SS1}$ (when pulled up)	-60	-18	-5	$\mu\text{A}$	
	$I_{IH1Z}$	$V_{IH1} = V_{DD}$ (in a high impedance state)	0	—	1.0	$\mu\text{A}$	
	$I_{IL1Z}$	$V_{IL1} = V_{SS1}$ (in a high impedance state)	-1.0	—	0	$\mu\text{A}$	
Input Current 2 (IN0, IN1)	$I_{IH2}$	$V_{IH2} = V_{DD}$ (when pulled down)	5	18	60	$\mu\text{A}$	
	$I_{IH2Z}$	$V_{IH2} = V_{DD}$ (in a high impedance state)	0	—	1.0	$\mu\text{A}$	
	$I_{IL2Z}$	$V_{IL2} = V_{SS1}$ (in a high impedance state)	-1.0	—	0	$\mu\text{A}$	
Input Current 3 (OSC1)	$I_{IL3}$	$V_{IL3} = V_{SS1}$ (when pulled up)	-60	-22	-6	$\mu\text{A}$	
	$I_{IH3Z}$	$V_{IH3} = V_{DD}$ (in a high impedance state)	0	—	1.0	$\mu\text{A}$	
	$I_{IL3Z}$	$V_{IL3} = V_{SS1}$ (in a high impedance state)	-1.0	—	0	$\mu\text{A}$	
Input Current 4 (RESET, TST1, TST2)	$I_{IH4}$	$V_{IH4} = V_{DD}$	0	—	1.0	$\mu\text{A}$	
	$I_{IL4}$	$V_{IL4} = V_{SS1}$	-1.5	-0.75	-0.3	$\text{mA}$	
Input Voltage 1 (P0.0 to P0.3) (P2.0 to P2.3) (P3.0 to P3.3)	$V_{IH1}$	—	-0.3	—	0	V	4
	$V_{IL1}$	—	-1.5	—	-1.2	V	
Input Voltage 2 (IN0, IN1, OSC1)	$V_{IH2}$	—	-0.3	—	0	V	
	$V_{IL2}$	—	-1.5	—	-1.2	V	
Input Voltage 3 (RESET, TST1, TST2)	$V_{IH3}$	—	-0.3	—	0	V	
	$V_{IL3}$	—	-1.5	—	-1.2	V	

## DC Characteristics (continued)

( $V_{DD} = 0\text{ V}$ ,  $V_{SS1} = V_{SSL} = -1.5\text{ V}$ ,  $V_{SS2} = -3.0\text{ V}$ ,  $V_{SS3} = -4.5\text{ V}$ ,  
 $T_a = -40\text{ to }+85^\circ\text{C}$  unless otherwise specified)

Parameter (Pin Name)	Symbol	Condition	Min.	Typ.	Max.	Unit	Measuring Circuit
Hysteresis Width (P0.0 to P0.3) (P2.0 to P2.3) (P3.0 to P3.3)	$\Delta V_{T1}$	—	0.05	0.1	0.3	V	4
Hysteresis Width (RESET, $\overline{\text{TST1}}$ , $\overline{\text{TST2}}$ )	$\Delta V_{T2}$	—	0.05	0.1	0.3	V	
Input Pin Capacitance (P0.0 to P0.3) (P2.0 to P2.3) (P3.0 to P3.3)	$C_{IN}$	—	—	—	5.0	pF	1

Measuring circuit 1

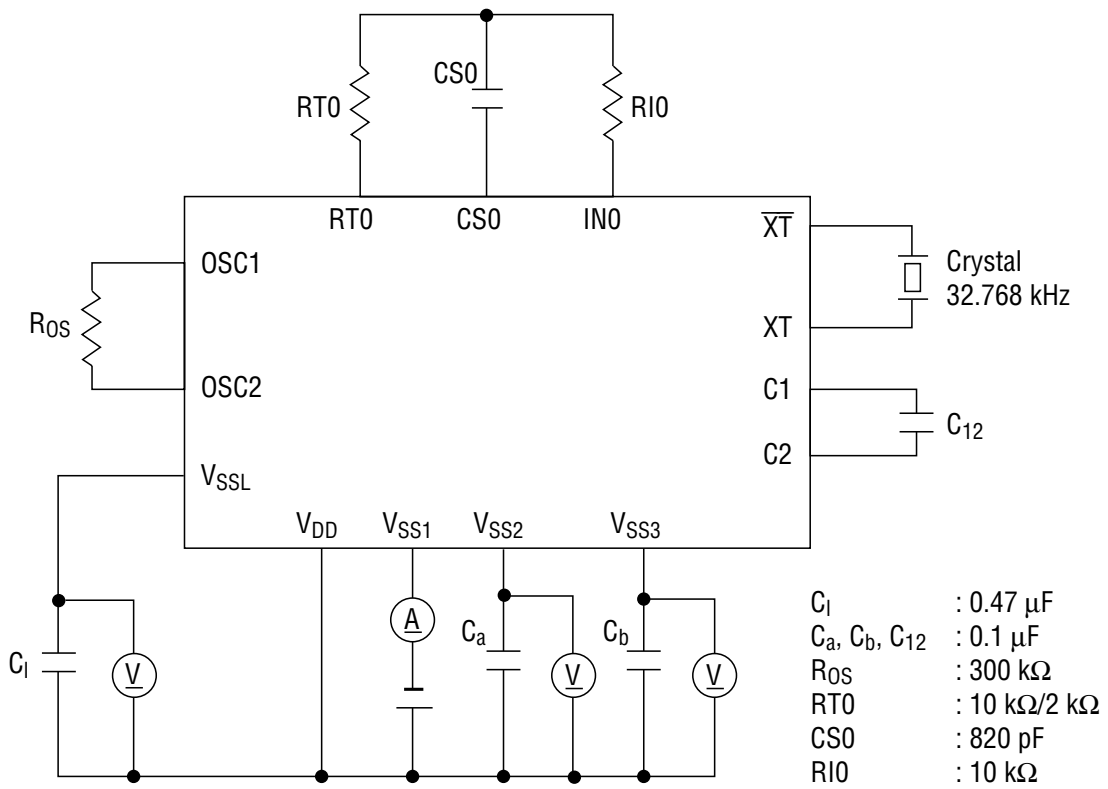

Measuring circuit 2

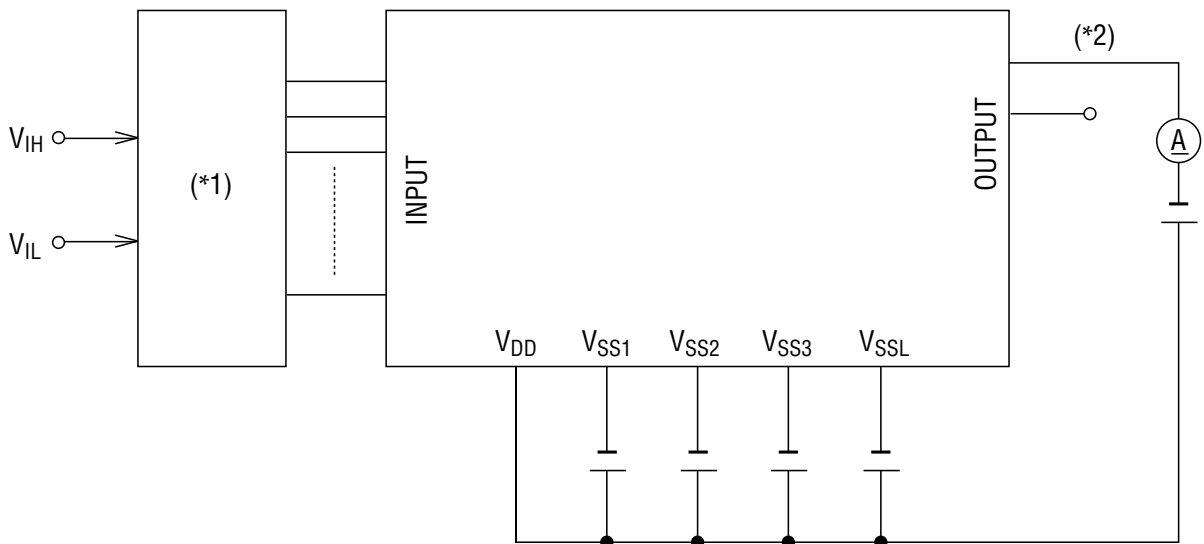

**Measuring circuit 3**

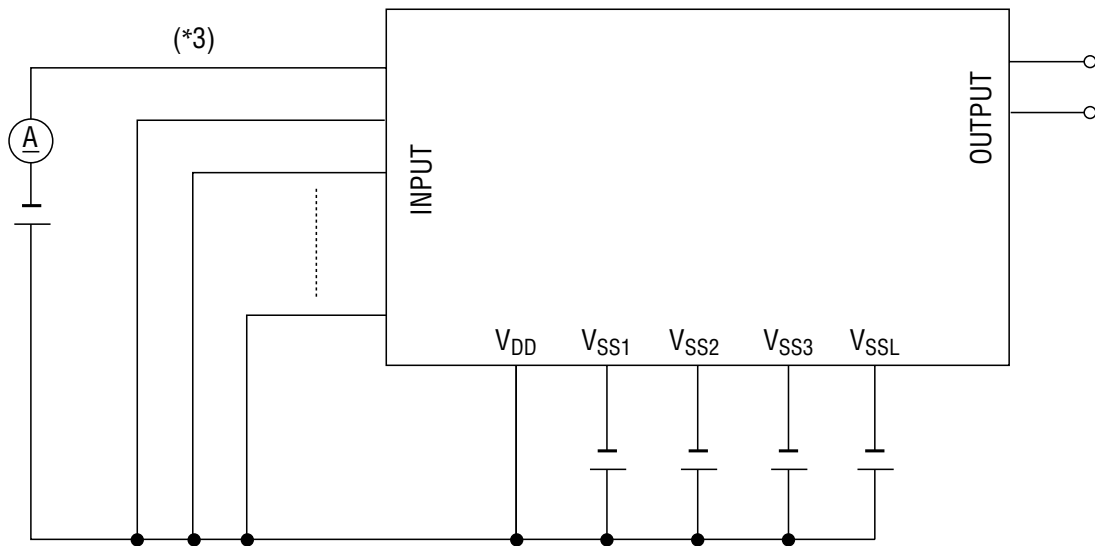

**Measuring circuit 4**

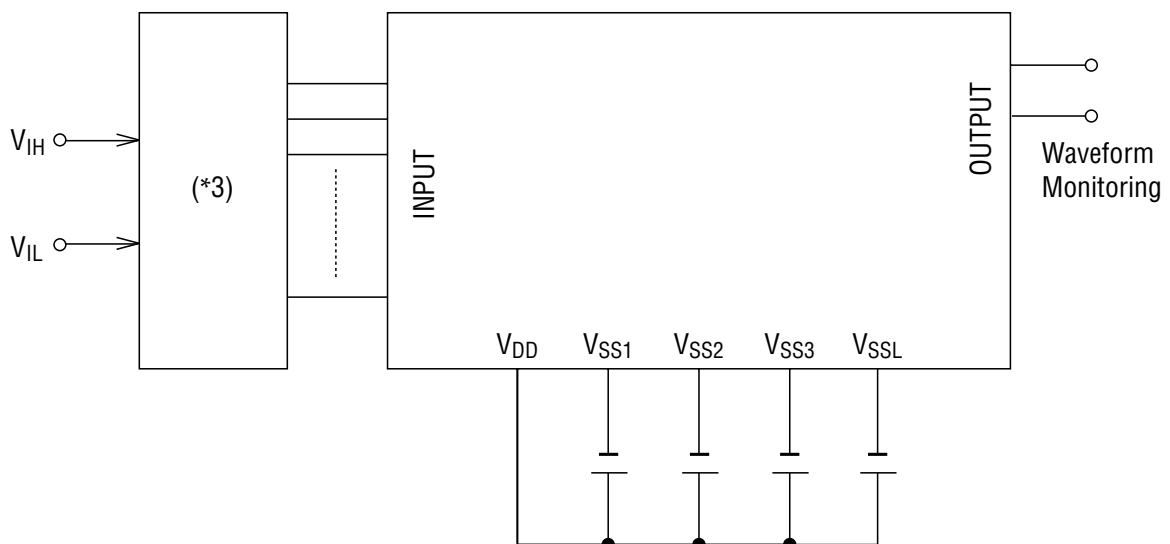

\*1 Input logic circuit to determine the specified measuring conditions.

\*2 Measured at the specified output pins.

\*3 Measured at the specified input pins.

**A/D Converter Characteristics**

(V<sub>DD</sub> = 0 V, V<sub>SS1</sub> = -1.5 V, T<sub>a</sub> = -40 to +85°C unless otherwise specified)

Parameter	Symbol	Condition	Min.	Typ.	Max.	Unit	Measuring Circuit
Resistor for Oscillation	RS0, RS1, RT0, RT0-1, RT1	CS0, CT0, CS1 ≥ 740 pF	2.0	—	—	kΩ	5
Input Current Limiting Resistor	RI0, RI1	—	1.0	10	—	kΩ	
Oscillation Frequency	f <sub>OSC1</sub>	Resistor for oscillation = 2 kΩ	165	221	256	kHz	
	f <sub>OSC2</sub>	Resistor for oscillation = 10 kΩ	41.8	52.2	60.6	kHz	
	f <sub>OSC3</sub>	Resistor for oscillation = 200 kΩ	2.55	3.04	3.53	kHz	
RS•RT Oscillation Frequency Ratio (*)	Kf1	RT0, RT0-1, RT1 = 2 kΩ	3.89	4.18	4.35	—	
	Kf2	RT0, RT0-1, RT1 = 10 kΩ	0.990	1.0	1.010	—	
	Kf3	RT0, RT0-1, RT1 = 200 kΩ	0.0561	0.0584	0.0637	—	

\* K<sub>fx</sub> is the ratio of the oscillation frequency by a sensor resistor to the oscillation frequency by a reference resistor in the same condition.

$$K_{fx} = \frac{f_{oscx} (RT0-CS0 \text{ Oscillation})}{f_{oscx} (RS0-CS0 \text{ Oscillation})}, \frac{f_{oscx} (RT0-1-CS0 \text{ Oscillation})}{f_{oscx} (RS0-CS0 \text{ Oscillation})}, \frac{f_{oscx} (RT1-CS1 \text{ Oscillation})}{f_{oscx} (RS1-CS1 \text{ Oscillation})}$$

(x = 1, 2, 3)

Measuring circuit 5

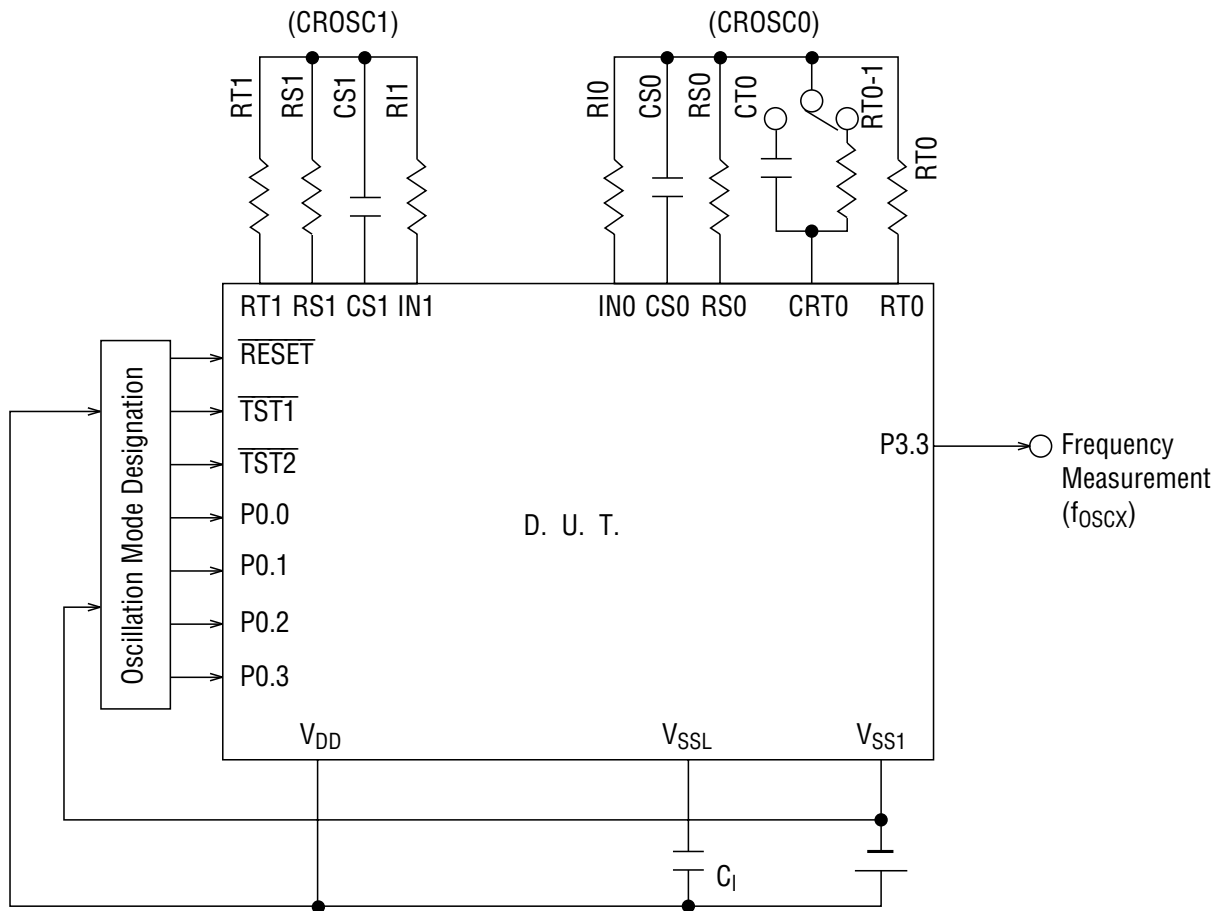

- RT0, RT0-1, RT1 = 2 kΩ/10 kΩ/200 kΩ
- RS0, RS1 = 10 kΩ
- RI0, RI1 = 10 kΩ
- CS0, CT0, CS1 = 820 pF
- C<sub>1</sub> = 0.1 μF

**ABSOLUTE MAXIMUM RATINGS (3.0 V Spec.)**(V<sub>DD</sub> = 0 V)

Parameter	Symbol	Condition	Rating	Unit
Power Supply Voltage 1	V <sub>SS1</sub>	Ta = 25°C	-2.0 to +0.3	V
Power Supply Voltage 2	V <sub>SS2</sub>	Ta = 25°C	-4.0 to +0.3	V
Power Supply Voltage 3	V <sub>SS3</sub>	Ta = 25°C	-5.5 to +0.3	V
Power Supply Voltage 4	V <sub>SSL</sub>	Ta = 25°C	-4.0 to +0.3	V
Input Voltage 1	V <sub>IN1</sub>	V <sub>SS2</sub> Input, Ta = 25°C	V <sub>SS2</sub> - 0.3 to +0.3	V
Input Voltage 2	V <sub>IN2</sub>	V <sub>SSL</sub> Input, Ta = 25°C	V <sub>SSL</sub> - 0.3 to +0.3	V
Output Voltage 1	V <sub>OUT1</sub>	V <sub>SS1</sub> Output, Ta = 25°C	V <sub>SS1</sub> - 0.3 to +0.3	V
Output Voltage 2	V <sub>OUT2</sub>	V <sub>SS2</sub> Output, Ta = 25°C	V <sub>SS2</sub> - 0.3 to +0.3	V
Output Voltage 3	V <sub>OUT3</sub>	V <sub>SS3</sub> Output, Ta = 25°C	V <sub>SSL</sub> - 0.3 to +0.3	V
Output Voltage 4	V <sub>OUT4</sub>	V <sub>SSL</sub> Output, Ta = 25°C	V <sub>SSL</sub> - 0.3 to +0.3	V
Storage Temperature	T <sub>STG</sub>	—	-55 to +150	°C

**RECOMMENDED OPERATING CONDITIONS (3.0 V Spec.)**(V<sub>DD</sub> = 0 V)

Parameter	Symbol	Condition	Range	Unit
Operating Temperature	T <sub>op</sub>	—	-40 to +85	°C
Operating Voltage	V <sub>SS2</sub>	Using LCD driver with "duty 1/2"	-3.5 to -2.2	V
		Except using LCD driver with "duty 1/2"	-3.5 to -2.0	
External 400 kHz RC Oscillator Resistance	R <sub>OS</sub>	—	90 to 500	kΩ
Crystal Oscillation Frequency	f <sub>XT</sub>	—	30 to 66	kHz



**ELECTRICAL CHARACTERISTICS (3.0 V Spec.)****DC Characteristics**(V<sub>DD</sub> = 0 V, V<sub>SS2</sub> = -3.0 V, T<sub>a</sub> = -40 to +85°C unless otherwise specified)

Parameter	Symbol	Condition	Min.	Typ.	Max.	Unit	Measuring Circuit
V <sub>SS1</sub> Voltage	V <sub>SS1</sub>	C <sub>a</sub> , C <sub>b</sub> , C <sub>12</sub> = 0.1 μF +100% -50%	-1.7	-1.5	-1.3	V	1
V <sub>SS3</sub> Voltage	V <sub>SS3</sub>	C <sub>a</sub> , C <sub>b</sub> , C <sub>12</sub> = 0.1 μF +100% -50%	-4.7	-4.5	-4.3	V	
V <sub>SSL</sub> Voltage	V <sub>SSL</sub>	—	-1.9	-1.3	-0.6	V	
Crystal Oscillation Start Voltage	V <sub>STA</sub>	Oscillation start time: within 5 seconds	—	—	-2.0	V	
Crystal Oscillation Hold Voltage	V <sub>HOLD</sub>	—	—	—	-2.0	V	
Crystal Oscillation Stop Detection Time	T <sub>STOP</sub>	—	0.1	—	1000	ms	
Internal Crystal Oscillator Capacitance	C <sub>G</sub>	—	10	15	20	pF	
External Crystal Oscillator Capacitance	C <sub>GEX</sub>	When external C <sub>G</sub> used	10	—	30	pF	
Internal Crystal Oscillator Capacitance	C <sub>D</sub>	—	10	15	20	pF	
Internal 400k RC Oscillator Capacitance	C <sub>OS</sub>	—	8	12	16	pF	
400k RC Oscillation Frequency	f <sub>OSC</sub>	External resistor R <sub>OS</sub> = 100 kΩ V <sub>SS2</sub> = -2.0 to -3.5 V	300	400	620	kHz	
POR Generation Voltage	V <sub>POR1</sub>	When V <sub>SS2</sub> is between V <sub>POR1</sub> and -3.0 V	-0.7	—	0	V	
POR Non-generation Voltage	V <sub>POR2</sub>	No POR when V <sub>SS2</sub> is between V <sub>POR2</sub> and -3.0 V	-3.0	—	-2.0	V	
Battery Check Reference Voltage	V <sub>RB</sub>	T <sub>a</sub> = 25°C	-0.73	-0.63	-0.53	V	2
V <sub>RB</sub> Temperature Variation	ΔV <sub>RB</sub>	—	—	-2.0	—	mV/°C	

Notes: 1. "POR" denotes Power On Reset.

2. "T<sub>STOP</sub>" indicates that if the crystal oscillator stops over the value of T<sub>STOP</sub>, the system reset occurs.

**DC Characteristics (continued)**

( $V_{DD} = 0\text{ V}$ ,  $V_{SS2} = -3.0\text{ V}$ ,  $T_a = -40\text{ to }+85^\circ\text{C}$  unless otherwise specified)

Parameter	Symbol	Condition	Min.	Typ.	Max.	Unit	Measuring Circuit	
Supply Current 1	$I_{DD1}$	CPU in halt state (400k RC oscillation halt)	$T_a = -40\text{ to }+40^\circ\text{C}$	—	1.5	4.5	$\mu\text{A}$	1
			$T_a = +40\text{ to }+85^\circ\text{C}$	—	1.5	30	$\mu\text{A}$	
Supply Current 2	$I_{DD2}$	CPU in operating state (400k RC oscillation halt)	$T_a = -40\text{ to }+40^\circ\text{C}$	—	5.0	15	$\mu\text{A}$	
			$T_a = +40\text{ to }+85^\circ\text{C}$	—	5.0	40	$\mu\text{A}$	
Supply Current 3	$I_{DD3}$	CPU in operating state (400k RC oscillation in operation) $R_{OS} = 100\text{k}\Omega$	—	220	450	$\mu\text{A}$		
Supply Current 4	$I_{DD4}$	CPU in halt state (400k RC oscillation halt), RC oscillator for A/D converter is in operating state	$RT0 = 10\text{ k}\Omega$	—	300	450	$\mu\text{A}$	
			$RT0 = 2\text{ k}\Omega$	—	1300	2000	$\mu\text{A}$	
Supply Current 5	$I_{DD5}$	Battery check circuit in operating state, CPU in operating state (400k RC oscillation halt)	—	55	150	$\mu\text{A}$		

DC Characteristics (continued)

( $V_{DD} = 0\text{ V}$ ,  $V_{SS1} = V_{SSL} = -1.5\text{ V}$ ,  $V_{SS2} = -3.0\text{ V}$ ,  $V_{SS3} = -4.5\text{ V}$ ,  
 $T_a = -40\text{ to }+85^\circ\text{C}$  unless otherwise specified)

Parameter (Pin Name)	Symbol	Condition	Min.	Typ.	Max.	Unit	Measuring Circuit
Output Current 1 (P1.0)	$I_{OH1}$	$V_{OH1} = -0.5\text{ V}$	-6.0	-2.0	-0.7	mA	2
	$I_{OL1}$	$V_{OL1} = V_{SS2} + 0.5\text{ V}$	3.0	8.0	25	mA	
Output Current 2 (P1.1 to P1.3) (P2.0 to P2.3) (P3.0 to P3.3)	$I_{OH2}$	$V_{OH2} = -0.5\text{ V}$	-6.0	-2.0	-0.7	mA	
	$I_{OL2}$	$V_{OL2} = V_{SS2} + 0.5\text{ V}$	0.7	2.0	6.0	mA	
Output Current 3 (BD)	$I_{OH3}$	$V_{OH3} = -0.7\text{ V}$	-6.0	-2.0	-0.7	mA	
	$I_{OL3}$	$V_{OL3} = V_{SS2} + 0.7\text{ V}$	0.7	2.0	6.0	mA	
Output Current 4 (RT0, RT1, RS0, RS1, CRT0, CS0, CS1)	$I_{OH4}$	$V_{OH4} = -0.1\text{ V}$	-2.5	-1.3	-0.7	mA	
	$I_{OL4}$	$V_{OL4} = V_{SS2} + 0.1\text{ V}$	0.7	1.3	2.5	mA	
Output Current 5 (When L16 to L23 are configured as output ports)	$I_{OH5}$	$V_{OH5} = -0.5\text{ V}$	-1.5	-0.6	-0.15	mA	
	$I_{OL5}$	$V_{OL5} = V_{SS2} + 0.5\text{ V}$	0.15	0.6	1.5	mA	
Output Current 6 (OSC2)	$I_{OH6}$	$V_{OH6} = -0.5\text{ V}$	-6.0	-2.0	-0.7	mA	
	$I_{OL6}$	$V_{OL6} = V_{SS2} + 0.5\text{ V}$	0.7	2.0	6.0	mA	
Output Current 7 (L0 to L23)	$I_{OH7}$	$V_{OH7} = -0.2\text{ V}$ ( $V_{DD}$ level)	—	—	-4.0	$\mu\text{A}$	
	$I_{OMH7}$	$V_{OMH7} = V_{SS1} + 0.2\text{ V}$ ( $V_{SS1}$ level)	4.0	—	—	$\mu\text{A}$	
	$I_{OMH7S}$	$V_{OMH7S} = V_{SS1} - 0.2\text{ V}$ ( $V_{SS1}$ level)	—	—	-4.0	$\mu\text{A}$	
	$I_{OML7}$	$V_{OML7} = V_{SS2} + 0.2\text{ V}$ ( $V_{SS2}$ level)	4.0	—	—	$\mu\text{A}$	
	$I_{OML7S}$	$V_{OML7S} = V_{SS2} - 0.2\text{ V}$ ( $V_{SS2}$ level)	—	—	-4.0	$\mu\text{A}$	
	$I_{OL7}$	$V_{OL7} = V_{SS3} + 0.2\text{ V}$ ( $V_{SS3}$ level)	4.0	—	—	$\mu\text{A}$	
Output Leakage Current (P1.0 to P1.3) (P2.0 to P2.3) (P3.0 to P3.3) (RT0, RT1, RS0, RS1, CRT0, CS0, CS1)	$I_{OOH}$	$V_{OH} = V_{DD}$	—	—	0.3	$\mu\text{A}$	
	$I_{OOL}$	$V_{OL} = V_{SS2}$	-0.3	—	—	$\mu\text{A}$	

DC Characteristics (continued)

( $V_{DD} = 0\text{ V}$ ,  $V_{SS1} = V_{SSL} = -1.5\text{ V}$ ,  $V_{SS2} = -3.0\text{ V}$ ,  $V_{SS3} = -4.5\text{ V}$ ,  
 $T_a = -40\text{ to }+85^\circ\text{C}$  unless otherwise specified)

Parameter (Pin Name)	Symbol	Condition	Min.	Typ.	Max.	Unit	Measuring Circuit
Input Current 1 (P0.0 to P0.3) (P2.0 to P2.3) (P3.0 to P3.3)	$I_{IH1}$	$V_{IH1} = V_{DD}$ (when pulled down)	30	90	300	$\mu\text{A}$	3
	$I_{IL1}$	$V_{IL1} = V_{SS2}$ (when pulled up)	-300	-90	-30	$\mu\text{A}$	
	$I_{IH1Z}$	$V_{IH1} = V_{DD}$ (in a high impedance state)	0	—	1.0	$\mu\text{A}$	
	$I_{IL1Z}$	$V_{IL1} = V_{SS2}$ (in a high impedance state)	-1.0	—	0	$\mu\text{A}$	
Input Current 2 (IN0, IN1)	$I_{IH2}$	$V_{IH2} = V_{DD}$ (when pulled down)	30	90	300	$\mu\text{A}$	
	$I_{IH2Z}$	$V_{IH2} = V_{DD}$ (in a high impedance state)	0	—	1.0	$\mu\text{A}$	
	$I_{IL2Z}$	$V_{IL2} = V_{SS2}$ (in a high impedance state)	-1.0	—	0	$\mu\text{A}$	
Input Current 3 (OSC1)	$I_{IL3}$	$V_{IL3} = V_{SS2}$ (when pulled up)	-300	-110	-10	$\mu\text{A}$	
	$I_{IH3Z}$	$V_{IH3} = V_{DD}$ (in a high impedance state)	0	—	1.0	$\mu\text{A}$	
	$I_{IL3Z}$	$V_{IL3} = V_{SS2}$ (in a high impedance state)	-1.0	—	0	$\mu\text{A}$	
Input Current 4 (RESET, TST1, TST2)	$I_{IH4}$	$V_{IH4} = V_{DD}$	0	—	1.0	$\mu\text{A}$	
	$I_{IL4}$	$V_{IL4} = V_{SS2}$	-3.0	-1.5	-0.75	mA	
Input Voltage 1 (P0.0 to P0.3) (P2.0 to P2.3) (P3.0 to P3.3)	$V_{IH1}$	—	-0.6	—	0	V	4
	$V_{IL1}$	—	-3.0	—	-2.4	V	
Input Voltage 2 (IN0, IN1, OSC1)	$V_{IH2}$	—	-0.6	—	0	V	
	$V_{IL2}$	—	-3.0	—	-2.4	V	
Input Voltage 3 (RESET, TST1, TST2)	$V_{IH3}$	—	-0.6	—	0	V	
	$V_{IL3}$	—	-3.0	—	-2.4	V	

DC Characteristics (continued)

( $V_{DD} = 0\text{ V}$ ,  $V_{SS1} = V_{SSL} = -1.5\text{ V}$ ,  $V_{SS2} = -3.0\text{ V}$ ,  $V_{SS3} = -4.5\text{ V}$ ,  
 $T_a = -40\text{ to }+85^\circ\text{C}$  unless otherwise specified)

Parameter (Pin Name)	Symbol	Condition	Min.	Typ.	Max.	Unit	Measuring Circuit
Hysteresis Width (P0.0 to P0.3) (P2.0 to P2.3) (P3.0 to P3.3)	$\Delta V_{T1}$	—	0.2	0.5	1.0	V	4
Hysteresis Width (RESET, TST1, TST2)	$\Delta V_{T2}$	—	0.2	0.5	1.0	V	
Input Pin Capacitance (P0.0 to P0.3) (P2.0 to P2.3) (P3.0 to P3.3)	$C_{IN}$	—	—	—	5.0	pF	1

Measuring circuit 1

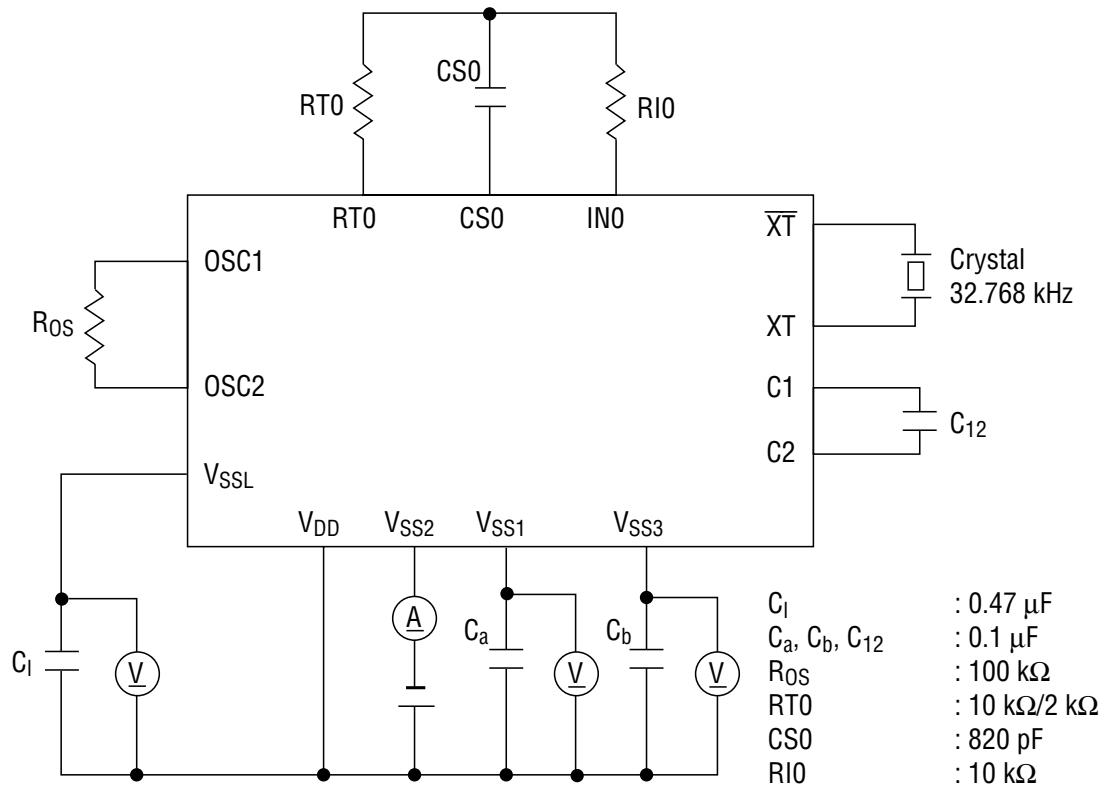

Measuring circuit 2

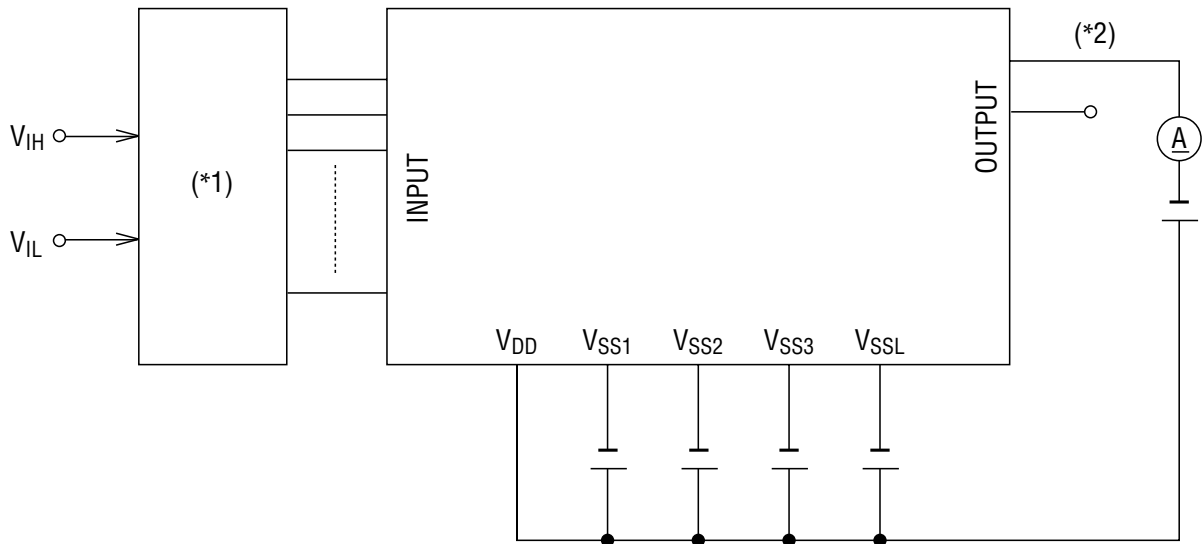

Measuring circuit 3

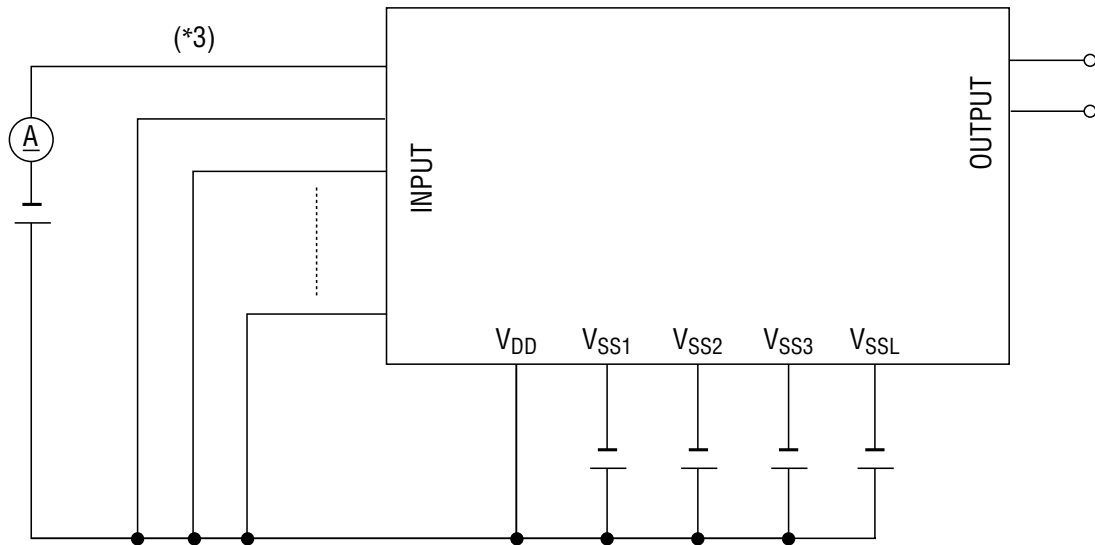

Measuring circuit 4

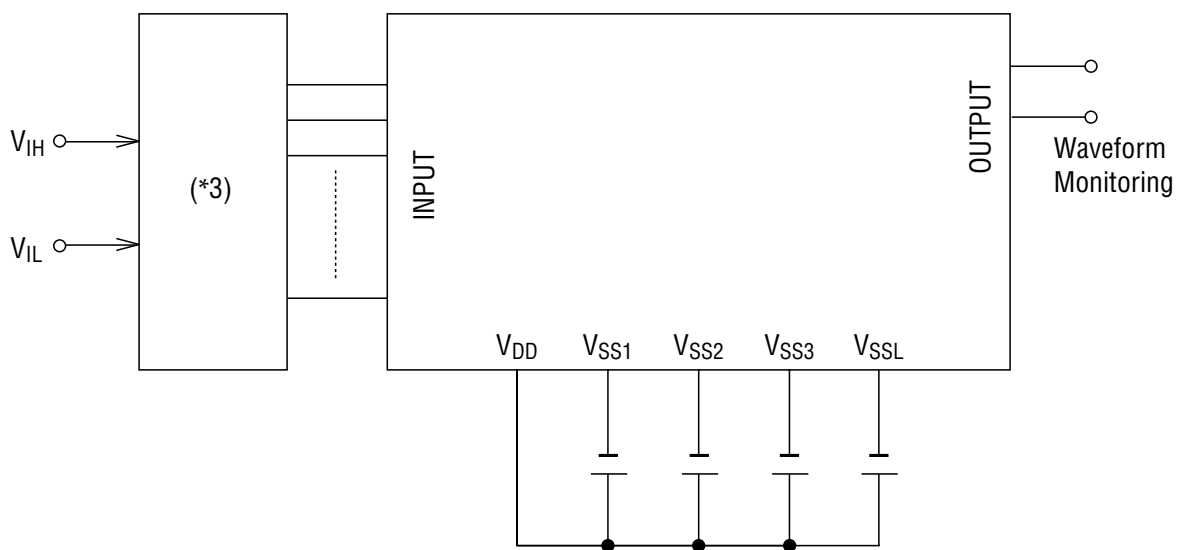

- \*1 Input logic circuit to determine the specified measuring conditions.
- \*2 Measured at the specified output pins.
- \*3 Measured at the specified input pins.

**A/D Converter Characteristics**

(V<sub>DD</sub> = 0 V, V<sub>SS2</sub> = -3.0 V, T<sub>a</sub> = -40 to +85°C unless otherwise specified)

Parameter	Symbol	Condition	Min.	Typ.	Max.	Unit	Measuring Circuit
Resistor for Oscillation	RS0, RS1, RT0, RT0-1, RT1	CS0, CT0, CS1 ≥ 740 pF	1.0	—	—	kΩ	5
Input Current Limiting Resistor	RI0, RI1	—	1.0	10	—	kΩ	
Oscillation Frequency	f <sub>OSC1</sub>	Resistor for oscillation = 2 kΩ	200	239	277	kHz	
	f <sub>OSC2</sub>	Resistor for oscillation = 10 kΩ	46.5	55.4	64.3	kHz	
	f <sub>OSC3</sub>	Resistor for oscillation = 200 kΩ	2.79	3.32	3.85	kHz	
RS•RT Oscillation Frequency Ratio(*)	Kf1	RT0, RT0-1, RT1 = 2 kΩ	4.115	4.22	4.326	—	
	Kf2	RT0, RT0-1, RT1 = 10 kΩ	0.990	1.0	1.010	—	
	Kf3	RT0, RT0-1, RT1 = 200 kΩ	0.0573	0.0616	0.0659	—	

\* K<sub>fx</sub> is the ratio of the oscillation frequency by a sensor resistor to the oscillation frequency by a reference resistor in the same condition.

$$K_{fx} = \frac{f_{oscx} \text{ (RT0-CS0 Oscillation)}}{f_{oscx} \text{ (RS0-CS0 Oscillation)}} , \frac{f_{oscx} \text{ (RT0-1-CS0 Oscillation)}}{f_{oscx} \text{ (RS0-CS0 Oscillation)}} , \frac{f_{oscx} \text{ (RT1-CS1 Oscillation)}}{f_{oscx} \text{ (RS1-CS1 Oscillation)}} \\ (x = 1, 2, 3)$$



Measuring circuit 5

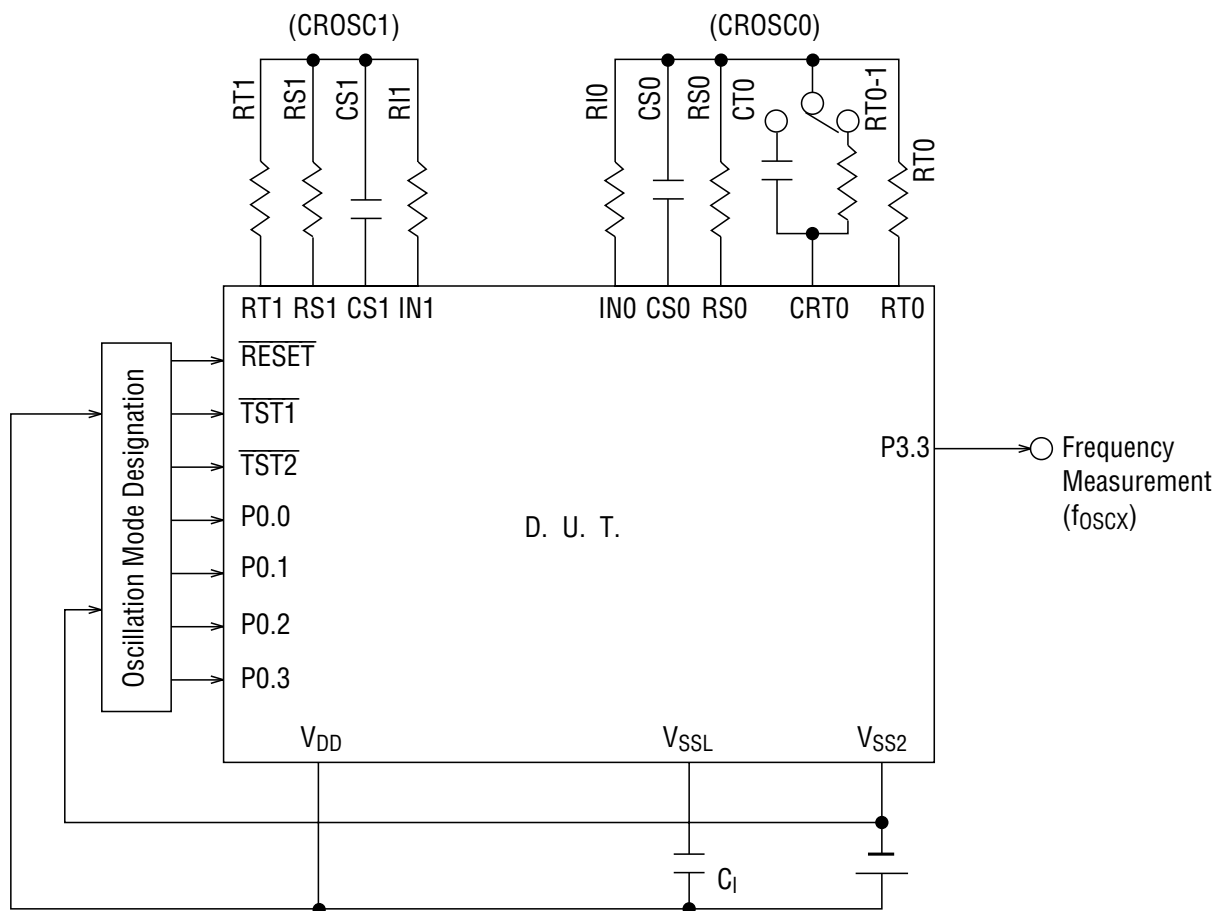

- RT0, RT0-1, RT1 = 2 kΩ/10 kΩ/200 kΩ
- RS0, RS1 = 10 kΩ
- RIO, RI1 = 10 kΩ
- CS0, CT0, CS1 = 820 pF
- C<sub>I</sub> = 0.47 μF

## FUNCTIONAL DESCRIPTION

### • A/D converter (ADC)

The MSM64162 has a built-in 2-channel RC oscillation type A/D converter. The A/D converter is composed of a 2-channel oscillation circuit, Counter A (CNTA0-4, a 4.8-digit decade counter), Counter B (CNTB0-3, a 14-bit binary counter), and A/D Converter Control Registers 0 and 1 (ADCON0, ADCON1).

By counting oscillation frequencies that vary depending on a resistor or capacitor connected to the RC oscillation circuit, the A/D converter converts resistance values or capacitance values to corresponding digital values. By using a thermistor or humidity sensor as a resistance, a thermometer or a hygrometer can be constructed. By applying a separate sensor to each channel of the 2-channel RC oscillation circuit, it is also possible to extend measure ranges or measure at two places.

### • LCD driver (LCD)

The MSM64162 has a built-in LCD driver for 24 outputs.

The LCD driver consists of  $21 \times 4$ -bit display registers (DSPR0-20), the Display Control Register (DSPCON), a 24-output LCD driver circuit, and a bias generation circuit (BIAS).

There are three types of driving methods: 1/4 duty, 1/3 duty and 1/2 duty. Software selects the duty mode.

A mask option can select either a common driver or a segment driver for each LCD driver pin.

A mask option can also specify assignment of each bit of the display register to each segment.

All the display registers must be selected by a mask option.

L16 to L23 of the LCD driver can be configured to be output ports by a mask option.

The relationship between the duty, the bias method, and the maximum segment number follows:

1/4 duty 1/3 bias method ----- 80 segments

1/3 duty 1/3 bias method ----- 63 segments

1/2 duty 1/2 bias method ----- 44 segments

### • Buzzer driver (BD)

The MSM64162 has a built-in buzzer driver with 2 buzzer output frequencies and 4 buzzer output modes. Each buzzer output is selected by the Buzzer Control Register (BDCON) and the Buzzer Frequency Control Register (BFCON).

### • Capture circuit (CAPR)

The MSM64162 captures 32 Hz to 256 Hz output of the time base counter at the falling of Port 0.0 or 0.1 (P0.0 or P0.1) to "L" level when the pull-up resistor input is chosen, or at the rising to "H" level when the pull-down resistor input is chosen. The capture circuit is composed of the Capture Control Register (CAPCON) and the Capture Registers (CAPR0, CAPR1) that fetch output from the time base counter.

### • Watchdog timer (WDT)

The MSM64162 has a built-in watchdog timer to detect CPU malfunction. The watchdog timer is composed of a 6-bit watchdog timer counter (WDTC) to count a 16 Hz output and a watchdog timer control register (WDTCON) to reset WDTC.

### • Clock generation circuit (2CLK)

The clock generation circuit (2CLK) in the MSM64162 contains a 32.768 kHz crystal oscillation circuit, a 400 kHz RC oscillation circuit, and a clock control port. This circuit generates the system clock (CLK) and the time base clock (32.768 kHz).

The system clock drives the CPU while the time base clock drives the time base counter and the buzzer driver.

Via the contents of the frequency Control Register (FCON), the system clock can be switched between 32.768 kHz (the output of the crystal oscillation circuit) and 400 kHz (the output of the RC oscillation circuit).

Note: The oscillation frequency of the RC oscillation circuit varies depending on the value of an external resistor ( $R_{OS}$ ), operating power supply voltage ( $V_{DD}$ ), and ambient temperatures ( $T_a$ ).

### • Time base counter (TBC)

The MSM64162 has a built-in time base counter (TBC) that generates clocks to be supplied to internal peripheral circuits. The time base counter is composed of 15 binary counters. The count clock of the time base is driven by the oscillation clock (32.768 kHz) of the crystal oscillation circuit. The output of the time base counter is used for the buzzer driver, the system reset circuit, the watchdog timer, the time base interrupt, the sampling clocks of each port, and the capture circuit.

### • I/O port

Input-output ports (P2, P3) (8 bits)	: Pull-up (pull-down) resistor input or high-impedance input, CMOS output or NMOS open drain output: these can be specified for each bit; external 0 interrupt
Input port (P0) (4 bits)	: Pull-up (pull-down) resistor input or high-impedance input; external 1 interrupt
Output port (P1) (4 bits)	: CMOS output or NMOS open drain output

### • Interrupt (INTC)

The MSM64162 has 9 interrupt sources (9 vector addresses), of which two are external interrupts from ports and seven are internal interrupts.

Of the nine interrupt sources, only the watchdog interrupt cannot be disabled (non-maskable interrupt). The other eight interrupts are controlled by the master interrupt enable flag (MI) and the interrupt enable registers (IE0, IE1 and IE2). When an interrupt condition is met, the CPU branches to a vector address corresponding to the interrupt source.

### • Battery check circuit (BC)

The battery check circuit (BC) detects the level of the supply voltage by comparing the voltage generated by an external supply-voltage dividing resistor (RBLD) with the internal reference voltage ( $V_{rb}$ ).

APPLICATION CIRCUITS

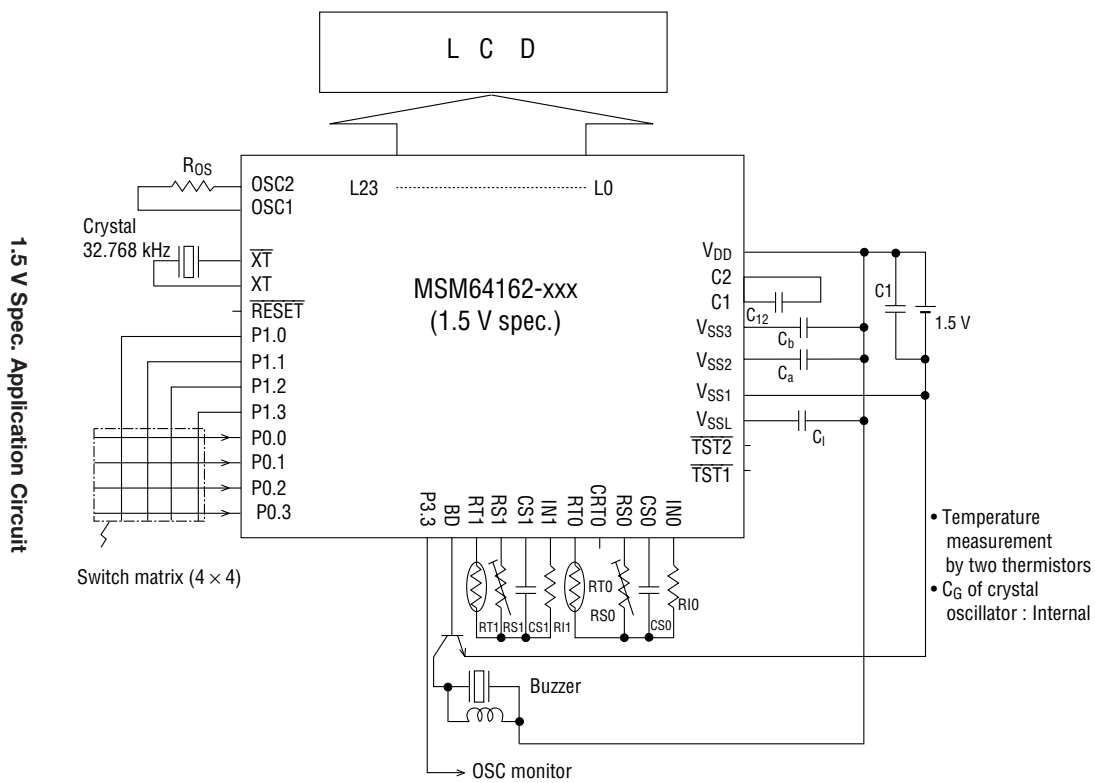

APPLICATION CIRCUITS (continued)

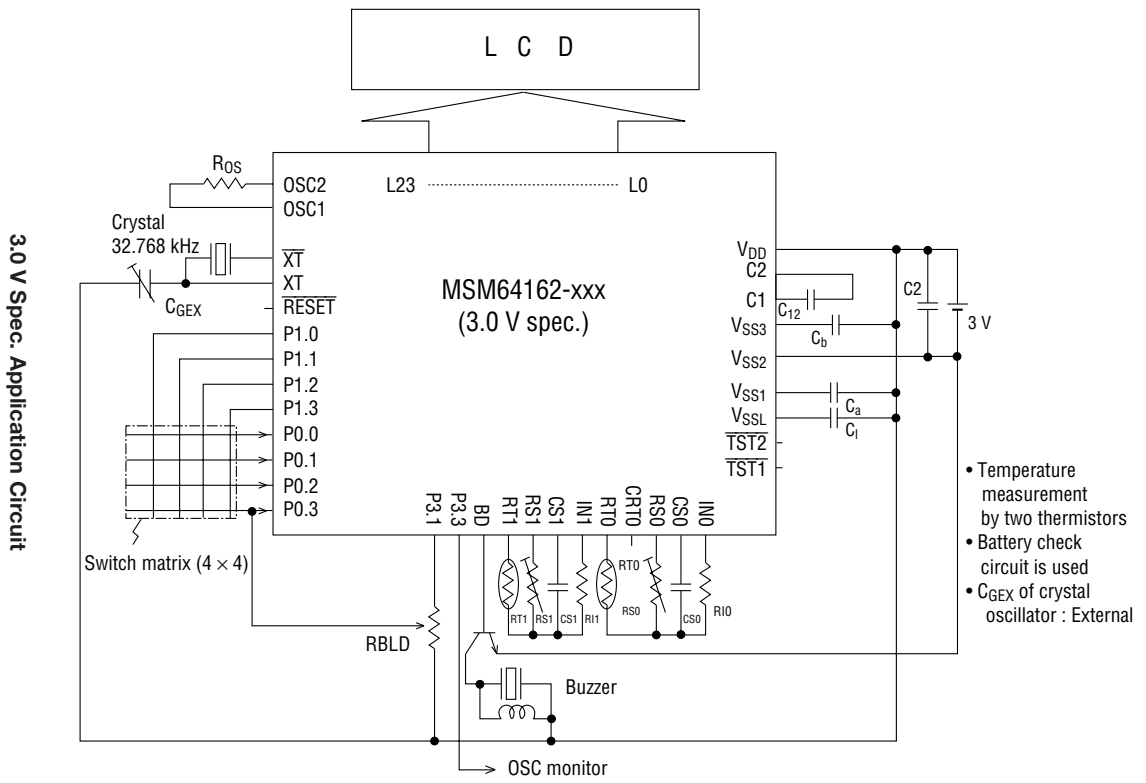

PACKAGE DIMENSIONS

(Unit : mm)

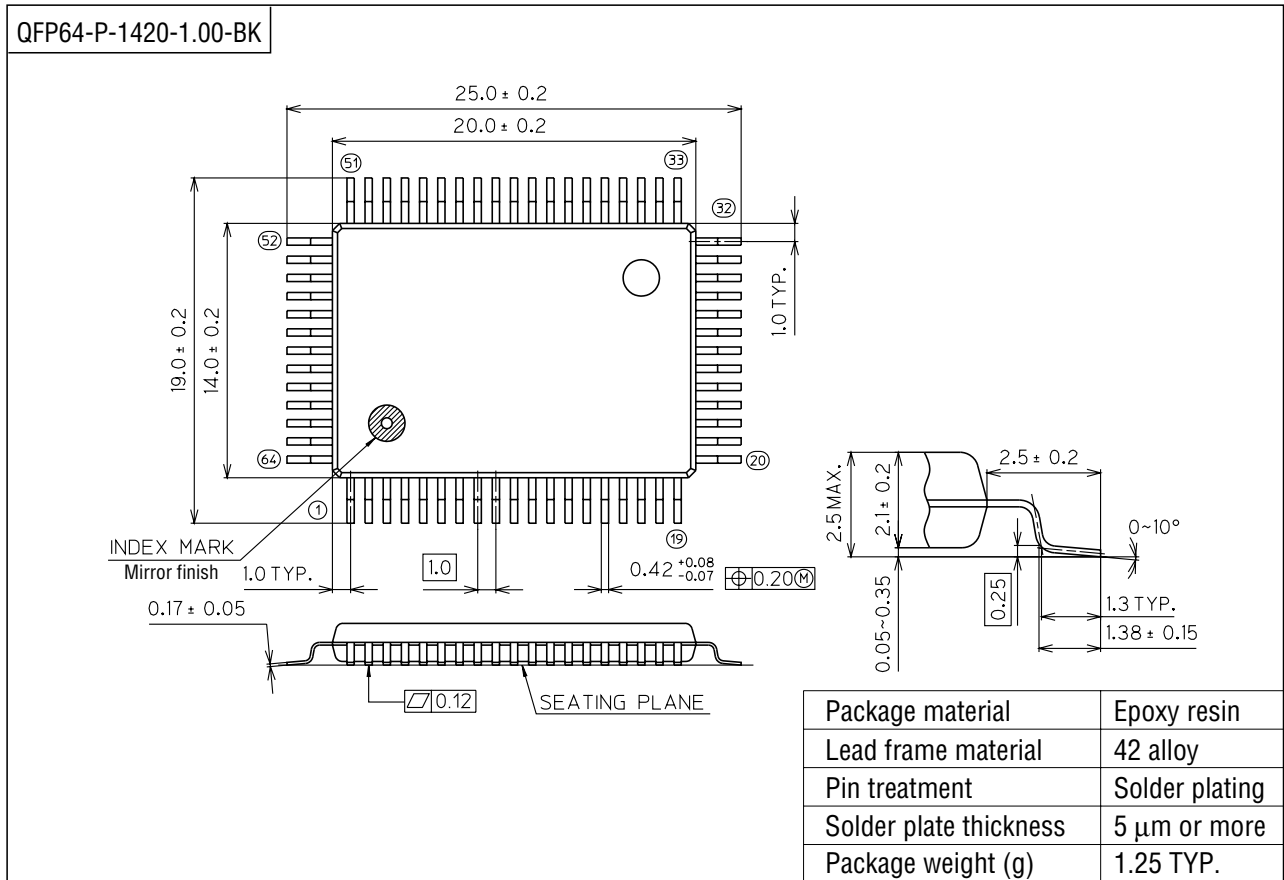

Notes for Mounting the Surface Mount Type Package

The SOP, QFP, TSOP, SOJ, QFJ (PLCC), SHP and BGA are surface mount type packages, which are very susceptible to heat in reflow mounting and humidity absorbed in storage. Therefore, before you perform reflow mounting, contact Oki's responsible sales person for the product name, package name, pin number, package code and desired mounting conditions (reflow method, temperature and times).

(Unit : mm)

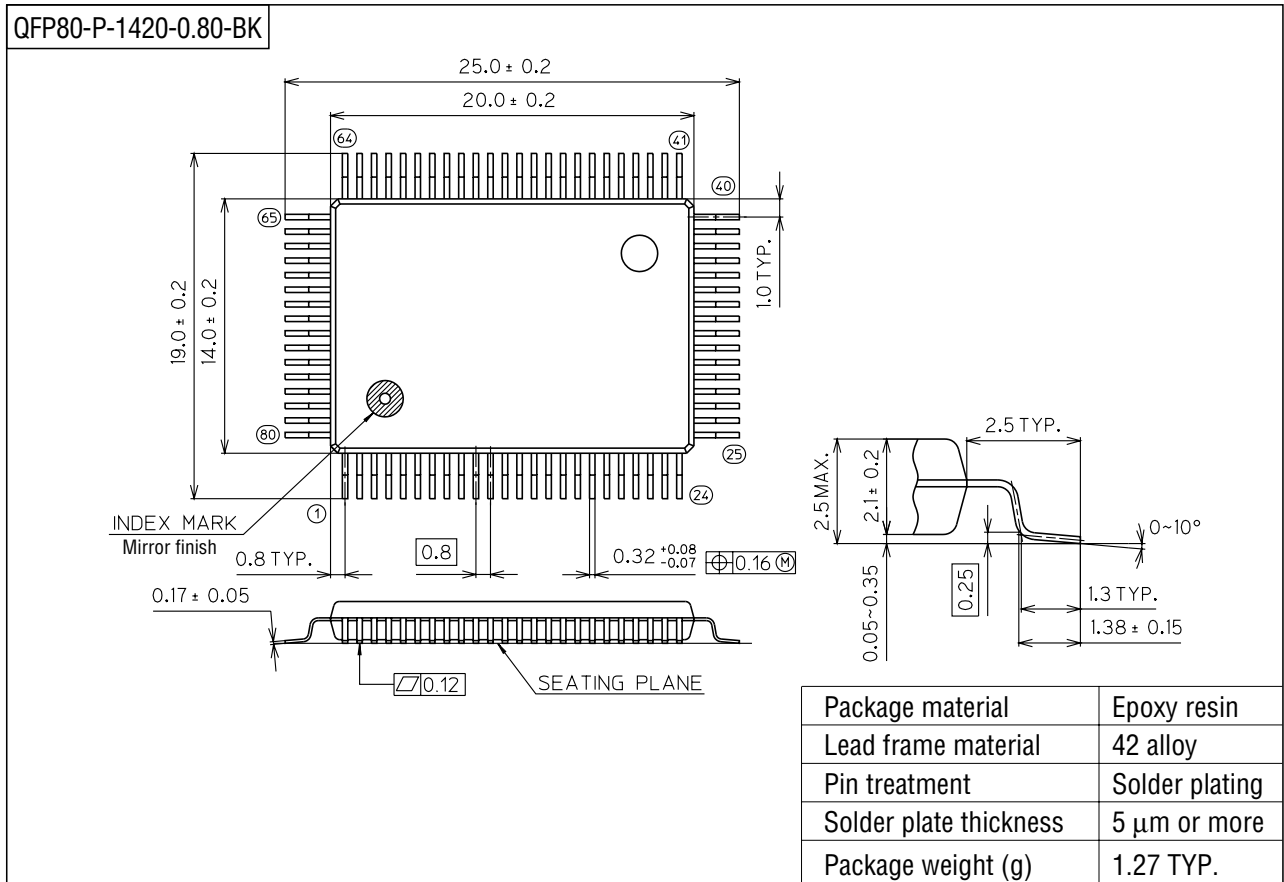

Notes for Mounting the Surface Mount Type Package

The SOP, QFP, TSOP, SOJ, QFJ (PLCC), SHP and BGA are surface mount type packages, which are very susceptible to heat in reflow mounting and humidity absorbed in storage. Therefore, before you perform reflow mounting, contact Oki's responsible sales person for the product name, package name, pin number, package code and desired mounting conditions (reflow method, temperature and times).