

# OKI Semiconductor

## MSM64P155/64P155L

### 4-Bit Microcontroller with Built-in LCD Driver and Melody Circuit

#### GENERAL DESCRIPTION

The MSM64P155 (1.5 V)/64P155L (3.0 V) is a one-time-programmable ROM version product, which has one-time PROM (OTP) as internal program memory. On the other hand, the MSM64155 is a mask ROM-version product, which has mask ROM as internal program memory. Unlike the mask ROM-version MSM64155 which has a P-well CMOS structure, the MSM64P155/64P155L has been fabricated with the N-well CMOS-structured EPROM process technology. Therefore, the MSM64P155/64P155L differs from the MSM64155 in the polarity of the power supply for LCD bias generation and in the external circuit structure.

Unlike the mask ROM-version product, the MSM64P155/64P155L cannot be supplied in the form of a chip. The MSM64P155/64P155L is an OTP-version product used to evaluate an application program.

The MSM64P155/64P155L has two operation modes, microcontroller operation mode and PROM mode. The microcontroller operation mode is used to operate the MSM64P155/64P155L like a mask ROM-version product and the PROM mode is used to program or read the PROM.

#### FEATURES

- Operating range
  - Operating voltage (mask option) : 1.5 V/3.0 V
  - Operating frequency : 32.768 kHz crystal oscillation  
Approx. 32 kHz RC oscillation
- Minimum instruction execution time : 91  $\mu$ s
- General memory space : 4064 bytes (PROM)
- Local memory space : 256 nibbles
- LCD driver : 64
  - Common driver  $\times$  4
  - Segment driver  $\times$  60
  - 1/4 duty, 1/3 bias; 240 segments (60  $\times$  4)
  - 1/3 duty, 1/3 bias; 180 segments (60  $\times$  3)
- I/O port
  - Input-output port : 2 ports  $\times$  4 bits (open-drain output/CMOS output selectable; pull-down resistor input/high-impedance input selectable)
  - Input port : 1 port  $\times$  2 bits (pull-down resistor input/high-impedance input selectable)  
1 port  $\times$  4 bits (pull-down resistor input/high-impedance input selectable)
  - Output port : 1 port  $\times$  4 bits (CMOS output)
- Event counter : 1 channel
- Melody output : 2
- Capture circuits : 2 channels  
256 Hz, 128 Hz, 64 Hz, 32 Hz

- Interrupt sources : 10 sources  
External 4, time base 4, melody 2  
(When TST3 = "1", six time base sources)
- Clock generation circuit (mask option) : Crystal/RC oscillation
- Package:  
100-pin plastic QFP (QFP100-P-1420-0.65-BK)  
Product name :  
MSM64P155-001GS-BK (crystal oscillation, 1.5 V, blanked PROM)  
MSM64P155L-002GS-BK (crystal oscillation, 3.0 V, blanked PROM)  
MSM64P155-003GS-BK (RC oscillation, 1.5 V, blanked PROM)  
MSM64P155L-004GS-BK (RC oscillation, 3.0 V, blanked PROM)  
MSM64P155-xxxGS-BK (crystal/RC oscillation, 1.5 V, written PROM)  
MSM64P155L-xxxGS-BK (crystal/RC oscillation, 3.0 V, written PROM)  
xxx indicates a code number.

**BLOCK DIAGRAM**

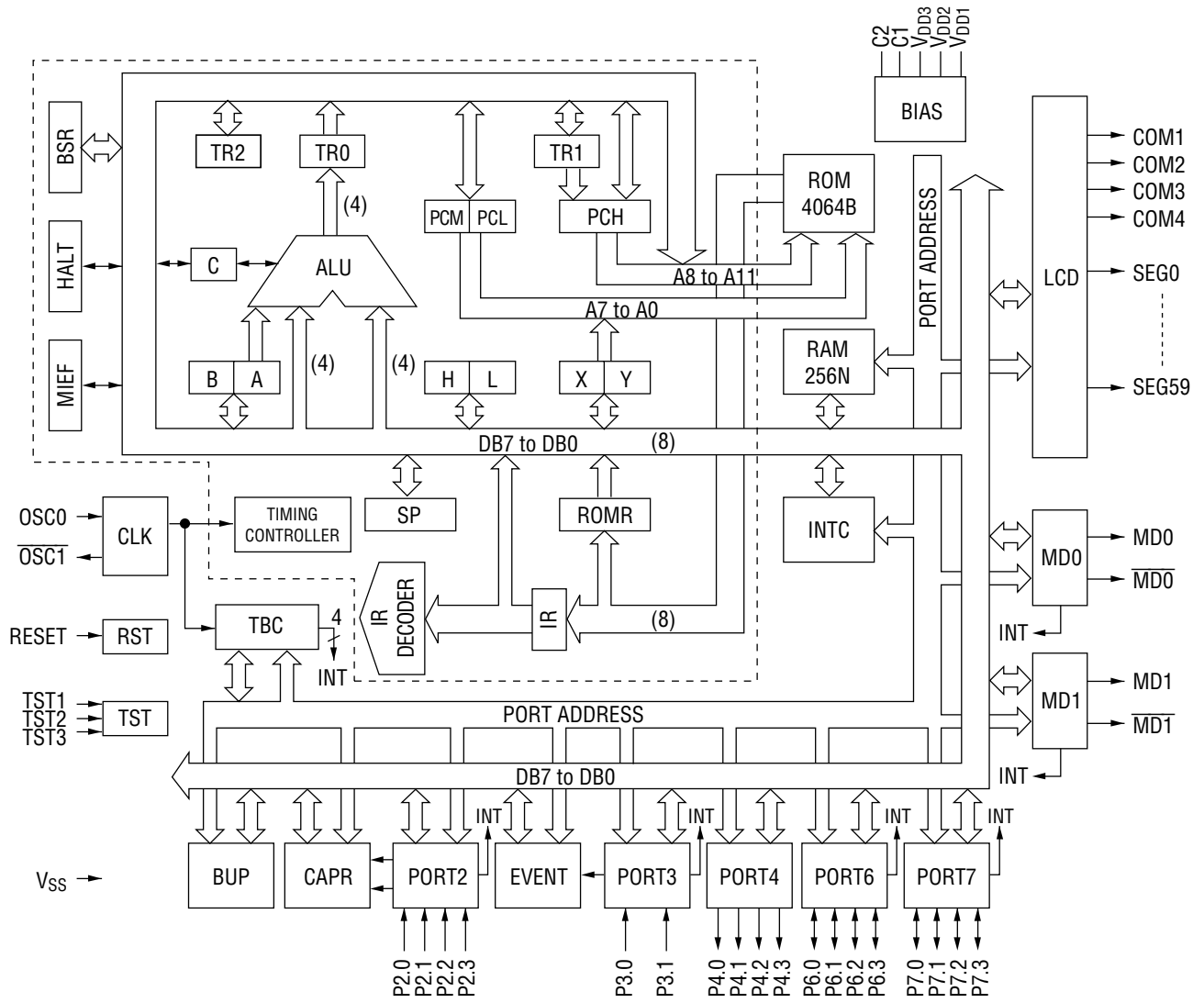

--- is the CPU core (nx-4/20).

**PIN CONFIGURATION (TOP VIEW)**

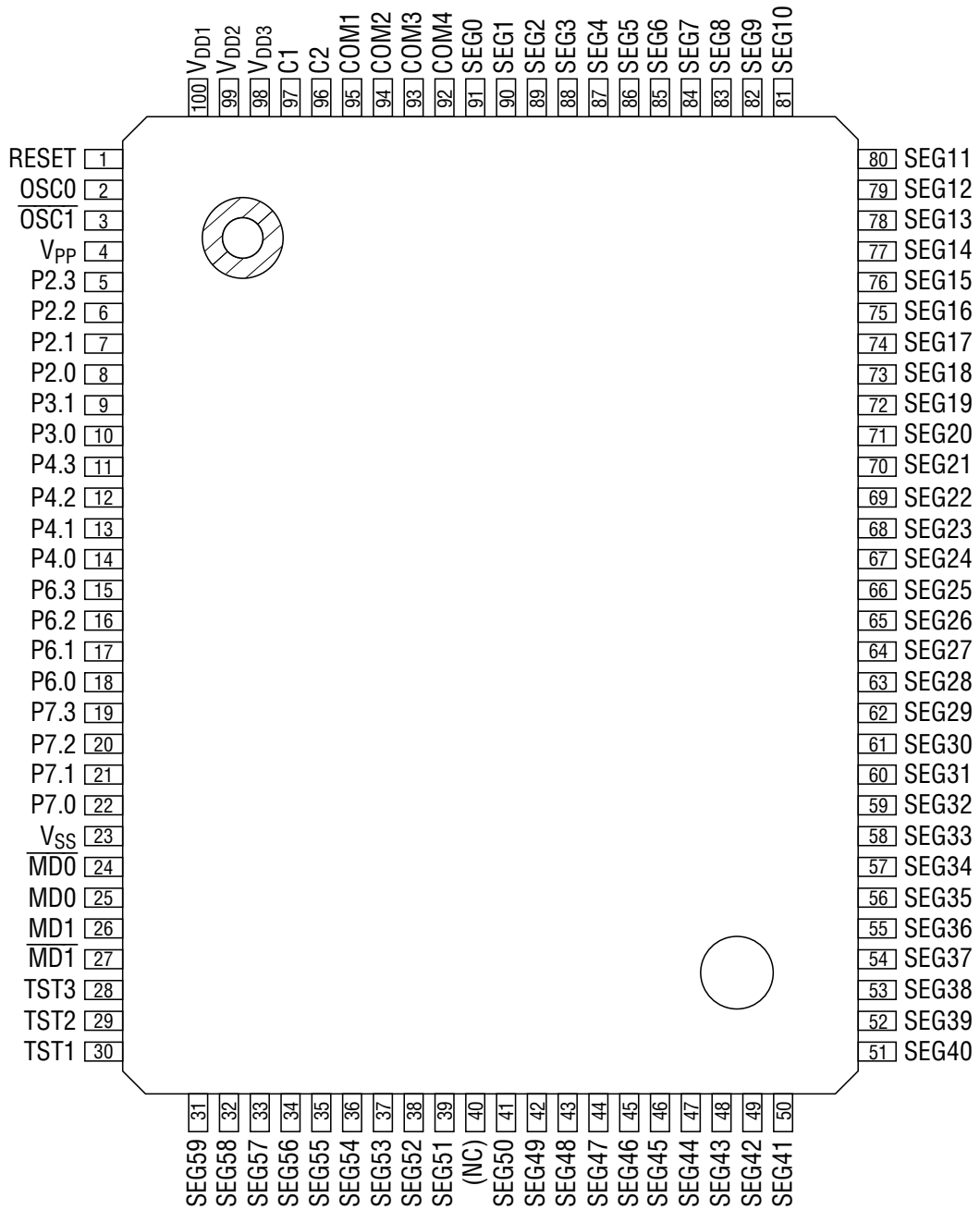

**100-Pin Plastic QFP**

Note: Pins marked as (NC) are no-connection pins which are left open.

## PIN DESCRIPTIONS

### Basic Functions

Function	Pin	Symbol	Type	Description
Power Supply	23	V <sub>SS</sub>	—	Digital supply voltage (0 V)
	100	V <sub>DD1</sub>	—	Digital positive power supply (1.5 V spec.) Bias output for LCD driver (3.0 V spec.)
	99	V <sub>DD2</sub>	—	Digital positive power supply (3.0 V spec.) Bias output for LCD driver (1.5 V spec.)
	98	V <sub>DD3</sub>	—	Bias output for LCD driver (+4.5 V)
	97	C1	—	Pins for connecting a capacitor for generating LCD driving bias
	96	C2	—	
	4	V <sub>PP</sub>	—	Positive power supply for writing programming data to PROM (+12.5 V)
Oscillation	2	OSC0	I	Clock oscillation pins: Either a crystal (32.768 kHz) and a capacitor (10 to 30 pF) are connected to these pins or a resistor (1 MΩ) is.
	3	OSC1	0	
Test	30	TST1	I	Input pins for test: These pins are internally pulled down to V <sub>SS</sub> .
	29	TST2	I	
	28	TST3	I	When this pin is set to "H" level, the 256 Hz and 4 Hz interrupts are enabled, and then the MSM64P155 can be used as an OTP version of the MSM64152A, MSM64153A, and MSM64158A.
RESET	1	RESET	I	System reset input pin : Setting this pin to "H" level puts this device into a reset state. Then, setting this pin to "L" level starts executing an instruction from address 000H. This pin is internally connected to V <sub>SS</sub> through a pull-down resistor.

## Basic Functions (continued)

Function	Pin	Symbol	Type	Description
Ports	8	P2.0	I	4-bit input port (port 2) : Select between pull-down resistor input and high impedance input for each bit with the port 2 control register (P2CON). When configured for secondary functions, an external interrupt and capture circuit trigger input are allocated. If P2.0 to P2.3 are set to "H" level, the device enters system reset mode.
	7	P2.1		
	6	P2.2		
	5	P2.3		
	10	P3.0	I	2-bit input port (port 3) : Select between pull-down resistor input and high impedance input with the port 3 control register (P3CON). When configured for a secondary function, an external interrupt is allocated to P3.0 and an event counter is allocated to P3.1.
	9	P3.1		
	14	P4.0	O	4-bit output port (port 4) : 4-bit CMOS output port.
	13	P4.1		
	12	P4.2		
	11	P4.3		
	18	P6.0	I/O	4-bit input-output port (port 6) : Select between input and output, between pull-down resistor input and high impedance input, and between open-drain output and CMOS output with the port 6 control register (P6CON). When configured for a secondary function, an external interrupt is allocated.
	17	P6.1		
	16	P6.2		
	15	P6.3		
	22	P7.0	I/O	4-bit input-output port (port 7) : Select between input and output, between pull-down resistor input and high impedance input, and between open-drain output and CMOS output with the port 7 control register (P7CON). When configured for a secondary function, an external interrupt is allocated.
	21	P7.1		
20	P7.2			
19	P7.3			
Melody Drivers	25	MD0	O	Output pin of melody driver 0.
	24	$\overline{\text{MD0}}$	O	Inverted output pin of MD0 output.
	26	MD1	O	Output pin of melody driver 1.
	27	$\overline{\text{MD1}}$	O	Inverted output pin of MD1 output.
LCD Drivers	95	COM1	O	LCD common signal output pins.
	94	COM2	O	
	93	COM3	O	
	92	COM4	O	

**Basic Functions (continued)**

<b>Function</b>	<b>Pin</b>	<b>Symbol</b>	<b>Type</b>	<b>Description</b>
LCD Drivers	91	SEG0	0	LCD segment signal output pins.
	90	SEG1	0	
	89	SEG2	0	
	88	SEG3	0	
	87	SEG4	0	
	86	SEG5	0	
	85	SEG6	0	
	84	SEG7	0	
	83	SEG8	0	
	82	SEG9	0	
	81	SEG10	0	
	80	SEG11	0	
	79	SEG12	0	
	78	SEG13	0	
	77	SEG14	0	
	76	SEG15	0	
	75	SEG16	0	
	74	SEG17	0	
	73	SEG18	0	
	72	SEG19	0	
	71	SEG20	0	
	70	SEG21	0	
	69	SEG22	0	
	68	SEG23	0	
	67	SEG24	0	
	66	SEG25	0	
	65	SEG26	0	
	64	SEG27	0	
	63	SEG28	0	
	62	SEG29	0	
	61	SEG30	0	
	60	SEG31	0	
	59	SEG32	0	
	58	SEG33	0	
	57	SEG34	0	
	56	SEG35	0	
	55	SEG36	0	
	54	SEG37	0	
	53	SEG38	0	
52	SEG39	0		

**Basic Functions (continued)**

<b>Function</b>	<b>Pin</b>	<b>Symbol</b>	<b>Type</b>	<b>Description</b>
LCD Drivers	51	SEG40	0	LCD segment signal output pins.
	50	SEG41	0	
	49	SEG42	0	
	48	SEG43	0	
	47	SEG44	0	
	46	SEG45	0	
	45	SEG46	0	
	44	SEG47	0	
	43	SEG48	0	
	42	SEG49	0	
	41	SEG50	0	
	39	SEG51	0	
	38	SEG52	0	
	37	SEG53	0	
	36	SEG54	0	
	35	SEG55	0	
	34	SEG56	0	
	33	SEG57	0	
	32	SEG58	0	
31	SEG59	0		



## Secondary Functions

Function	Pin	Symbol	Type	Description
External Interrupts	8	P2.0	I	P2.0 to P2.3 secondary functions : These are level-triggered external interrupt input pins. Select interrupt enable/disable for each bit with the P2 interrupt enable register (P2IE). If P2.0 to P2.3 pins are set to "H" level for a minimum of 2 seconds, the device enters system reset mode. P2.0, P2.1 secondary functions : trigger input pins for capture circuit.
	7	P2.1		
	6	P2.2		
	5	P2.3		
	10	P3.0	I	P3.0 secondary function : This is an input pin for external interrupt. This pin can receive an interrupt at a rising edge, a falling edge, or at both rising and falling edges.
	18	P6.0	I	P6.0 to P6.3 secondary functions : These are level-triggered external interrupt input pins.
	17	P6.1		
	16	P6.2		
	15	P6.3		
	22	P7.0	I	P7.0 to P7.3 secondary functions : These are level-triggered external interrupt input pins.
	21	P7.1		
	20	P7.2		
	19	P7.3		
Event Counter Input	9	P3.1	I	P3.1 secondary function : Input port for event counter

**PROM-Related Pins**

The pins for writing program data of the MSM64P155/64P155L are shown below.

Function	Pin	Symbol	Type	Description
Programming	23	$V_{SS}$	0	0 V power supply
	100	$V_{DD1}^*$	—	Positive power supply pin (+5 V)
	99	$V_{DD2}^*$	—	Positive power supply pin (+5 V)
	4	$V_{PP}$	—	Power supply pin for programming PROM (+12.5 V)
	1	RESET	I	PROM programming setting pins. When a "H" level is input to these pins, the device enters the PROM mode.
	30	TST1		
	29	TST2		
	91	SEG0/D0	I/O	Pins for writing or reading program data to and from PROM.
	90	SEG1/D1		
	89	SEG2/D2		
	88	SEG3/D3		
	87	SEG4/D4		
	86	SEG5/D5		
	85	SEG6/D6		
	84	SEG7/D7		
	83	SEG8/CE	I/O	PROM chip enable pin
	82	SEG9/OE	I/O	PROM output enable signal
	81	SEG10/A0	I	Program address input pins
	80	SEG11/A1		
	79	SEG12/A2		
	78	SEG13/A3		
	77	SEG14/A4		
	76	SEG15/A5		
	75	SEG16/A6		
	74	SEG17/A7		
	73	SEG18/A8		
	72	SEG19/A9		
71	SEG20/A10			
70	SEG21/A11			
69	SEG22	I	Normally apply a "H" level to this pin.	

\* When in PROM mode, supply a 5 V power to both  $V_{DD1}$  and  $V_{DD2}$ .

### Handling When Specific Pins Are Not Used

Symbol	Recommended Pin Connection
TST1 to TST3	Open
P2.0 to P2.3	"L" level or open
P3.0, P3.1	"L" level or open
P4.0 to P4.3	Open
P6.0 to P6.3	In input mode : "L" level or open (Initial setting: input mode) In output mode : Open
P7.0 to P7.3	In input mode : "L" level or open (Initial setting: input mode) In output mode : Open
MD0, $\overline{\text{MD0}}$ MD1, $\overline{\text{MD1}}$	Open
COM1 to COM4	Open
SEG0 to SEG59	Open

**(1) For 1.5 V Specifications in the Microcontroller Operation Mode**  
**Product Name: MSM64P155**

**ABSOLUTE MAXIMUM RATINGS**

(V<sub>SS</sub> = 0 V)

Parameter	Symbol	Condition	Rating	Unit
Power Supply Voltage 1	V <sub>DD1</sub>	T <sub>a</sub> = 25°C	-0.3 to +2.0	V
Power Supply Voltage 2	V <sub>DD2</sub>	T <sub>a</sub> = 25°C	-0.3 to +4.0	V
Power Supply Voltage 3	V <sub>DD3</sub>	T <sub>a</sub> = 25°C	-0.3 to +5.5	V
Input Voltage 1	V <sub>IN1</sub>	V <sub>DD1</sub> input, T <sub>a</sub> = 25°C	-0.3 to V <sub>DD1</sub> + 0.3	V
Output Voltage 1	V <sub>OUT1</sub>	V <sub>DD1</sub> output, T <sub>a</sub> = 25°C	-0.3 to V <sub>DD1</sub> + 0.3	V
Output Voltage 2	V <sub>OUT2</sub>	V <sub>DD2</sub> output, T <sub>a</sub> = 25°C	-0.3 to V <sub>DD2</sub> + 0.3	V
Output Voltage 3	V <sub>OUT3</sub>	V <sub>DD3</sub> output, T <sub>a</sub> = 25°C	-0.3 to V <sub>DD3</sub> + 0.3	V
Storage Temperature	T <sub>STG</sub>	—	-55 to +150	°C

**RECOMMENDED OPERATING CONDITIONS**

(V<sub>SS</sub> = 0 V)

Parameter	Symbol	Condition	Range	Unit
Operating Temperature	T <sub>op</sub>	—	0 to +65	°C
Operating Voltage	V <sub>DD1</sub>	—	1.4 to 1.7	V
Crystal Oscillation Frequency	f <sub>XT</sub>	—	30 to 35	kHz
External RC Oscillator Resistance	R <sub>OS</sub>	—	1M ±10%	Ω

## ELECTRICAL CHARACTERISTICS

### DC Characteristics

( $V_{SS} = 0\text{ V}$ ,  $V_{DD1} = 1.5\text{ V}$ ,  $T_a = 0\text{ to }+65^\circ\text{C}$  unless otherwise specified)

Parameter	Symbol	Condition	Min.	Typ.	Max.	Unit	Measuring Circuit
$V_{DD2}$ Voltage	$V_{DD2}$	$C_a, C_{12} = 1\ \mu\text{F}$ $C_b = 0.1\ \mu\text{F}$	2.8	3.0	3.2	V	1a
$V_{DD3}$ Voltage	$V_{DD3}$	$C_a, C_{12} = 1\ \mu\text{F}$ $C_b = 0.1\ \mu\text{F}$	4.3	4.5	4.7	V	
Crystal Oscillation Start Voltage	$V_{STA}$	Oscillation start time: within 5 seconds	1.47	—	—	V	
Crystal Oscillation Hold Voltage	$V_{HOLD}$	—	1.40	—	—	V	
External Crystal Oscillator Capacitance	$C_G$	—	10	—	30	pF	
Internal Crystal Oscillator Capacitance	$C_D$	—	10	15	20	pF	
RC Oscillation Frequency	$f_{CR}$	$R_{OS} = 1\ \text{M}\Omega$	15	40	75	kHz	

### DC Characteristics (32.768 kHz Crystal Oscillation)

( $V_{SS} = 0\text{ V}$ ,  $V_{DD1} = 1.5\text{ V}$ ,  $T_a = 0\text{ to }+65^\circ\text{C}$  unless otherwise specified)

Parameter	Symbol	Condition	Min.	Typ.	Max.	Unit	Measuring Circuit
Supply Current 1	$I_{DD1}$	CPU in the HALT mode	—	2.0	10	$\mu\text{A}$	1a
Supply Current 2	$I_{DD2}$	CPU in the operating mode	—	75	100	$\mu\text{A}$	

### DC Characteristics (RC Oscillation)

( $V_{SS} = 0\text{ V}$ ,  $V_{DD1} = 1.5\text{ V}$ ,  $R_{OS} = 1\ \text{M}\Omega$ ,  $T_a = 0\text{ to }+65^\circ\text{C}$  unless otherwise specified)

Parameter	Symbol	Condition	Min.	Typ.	Max.	Unit	Measuring Circuit
Supply Current 1	$I_{DD1}$	CPU in the HALT mode	—	3.0	20	$\mu\text{A}$	1b
Supply Current 2	$I_{DD2}$	CPU in the operating mode	—	100	200	$\mu\text{A}$	

**DC Characteristics (continued)**

( $V_{SS} = 0\text{ V}$ ,  $V_{DD1} = 1.5\text{ V}$ ,  $V_{DD2} = 3.0\text{ V}$ ,  $V_{DD3} = 4.5\text{ V}$ ,  $T_a = 0\text{ to }+65^\circ\text{C}$  unless otherwise specified)

Parameter	Symbol	Condition	Min.	Typ.	Max.	Unit	Measuring Circuit
Output Current 1 (P4.0 to P4.3) (MD0, MD0) (MD1, MD1)	$I_{OH1}$	$V_{OH1} = V_{DD1} - 0.5\text{ V}$	-2.0	-0.7	-0.1	mA	2
	$I_{OL1}$	$V_{OL1} = +0.5\text{ V}$	0.1	0.7	2.0	mA	
Output Current 2 (SEG0 to SEG59) (COM1 to COM4)	$I_{OH2}$	$V_{OH2} = V_{DD3} - 0.2\text{ V}$ ( $V_{DD3}$ level)	—	—	-4.0	$\mu\text{A}$	
	$I_{OMH2}$	$V_{OMH2} = V_{DD2} + 0.2\text{ V}$ ( $V_{DD2}$ level)	4.0	—	—	$\mu\text{A}$	
	$I_{OMH2S}$	$V_{OMH2S} = V_{DD2} - 0.2\text{ V}$ ( $V_{DD2}$ level)	—	—	-4.0	$\mu\text{A}$	
	$I_{OML2}$	$V_{OML2} = V_{DD1} + 0.2\text{ V}$ ( $V_{DD1}$ level)	4.0	—	—	$\mu\text{A}$	
	$I_{OML2S}$	$V_{OML2S} = V_{DD1} - 0.2\text{ V}$ ( $V_{DD1}$ level)	—	—	-4.0	$\mu\text{A}$	
	$I_{OL2}$	$V_{OL2} = +0.2\text{ V}$ ( $V_{SS}$ level)	4.0	—	—	$\mu\text{A}$	
Output Current 3 (P6.0 to P6.3) (P7.0 to P7.3)	$I_{OH3}$	$V_{OH3} = V_{DD1} - 0.5\text{ V}$	-5.0	-2.1	-0.3	mA	
	$I_{OL3}$	$V_{OL3} = +0.5\text{ V}$	0.1	0.7	2.0	mA	
Output Leakage (P6.0 to P6.3) (P7.0 to P7.3)	$I_{OOH}$	$V_{OH} = V_{DD1}$	—	—	0.3	$\mu\text{A}$	
	$I_{OOL}$	$V_{OL} = V_{SS}$	-0.3	—	—	$\mu\text{A}$	
Input Current 1 (P2.0 to P2.3) (P3.0, P3.1) (P6.0 to P6.3) (P7.0 to P7.3)	$I_{IH1}$	$V_{IH1} = V_{DD1}$ (when pulled down)	1.0	10	100	$\mu\text{A}$	3
	$I_{IH1Z}$	$V_{IH1} = V_{DD1}$ (in a high impedance state)	0	—	1.0	$\mu\text{A}$	
	$I_{IL1}$	$V_{IL1} = V_{SS}$	-1.0	—	0	$\mu\text{A}$	
Input Current 2 (TST1, TST2)	$I_{IH2}$	$V_{IH2} = V_{DD1}$	0.3	0.75	1.5	mA	
	$I_{IL2}$	$V_{IL2} = V_{SS}$	-1.0	—	0	$\mu\text{A}$	
Input Current 3 (TST3)	$I_{IH3}$	$V_{IH3} = V_{DD1}$	0.3	1.0	5.0	$\mu\text{A}$	
	$I_{IL3}$	$V_{IL3} = V_{SS}$	0	—	1.0	$\mu\text{A}$	
Input Current 4 (RESET)	$I_{IH4}$	$V_{IH4} = V_{DD1}$	15	40	100	$\mu\text{A}$	
	$I_{IL4}$	$V_{IL4} = V_{SS}$	-1	—	0	$\mu\text{A}$	
Input Voltage 1 (P2.0 to P2.3) (P3.0, P3.1) (P6.0 to P6.3) (P7.0 to P7.3) (TST1, TST2, TST3) (RESET)	$V_{IH1}$	—	-0.3	—	0	V	4
	$V_{IL1}$	—	-1.5	—	-1.2	V	

Measuring circuit 1a

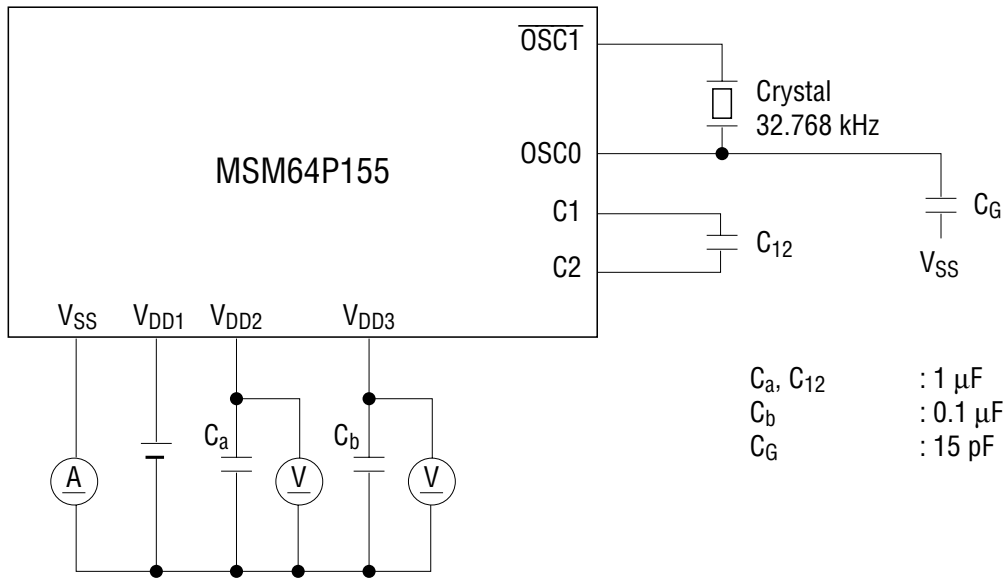

Measuring circuit 1b

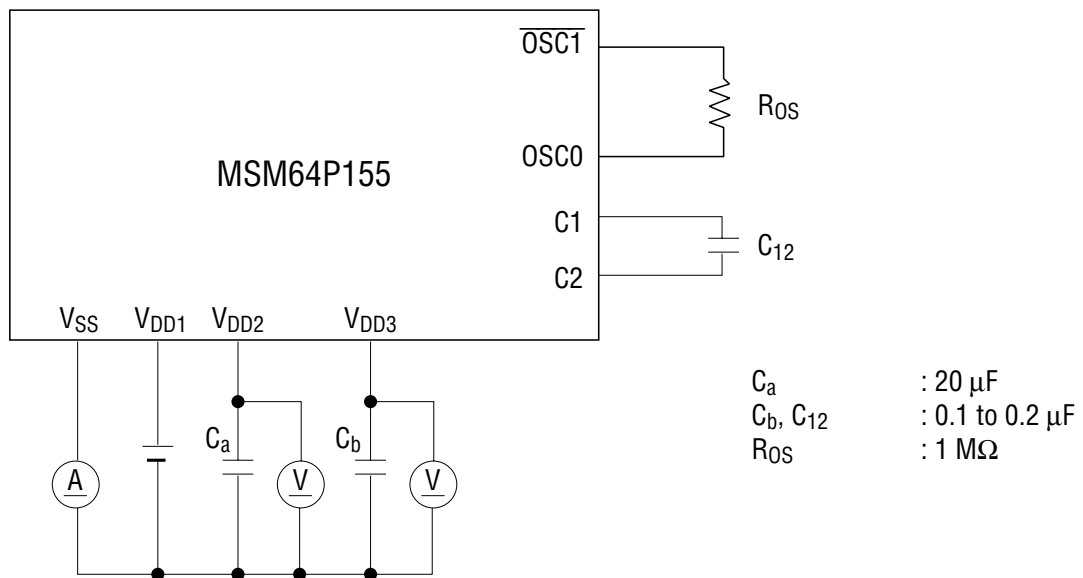

Measuring circuit 2

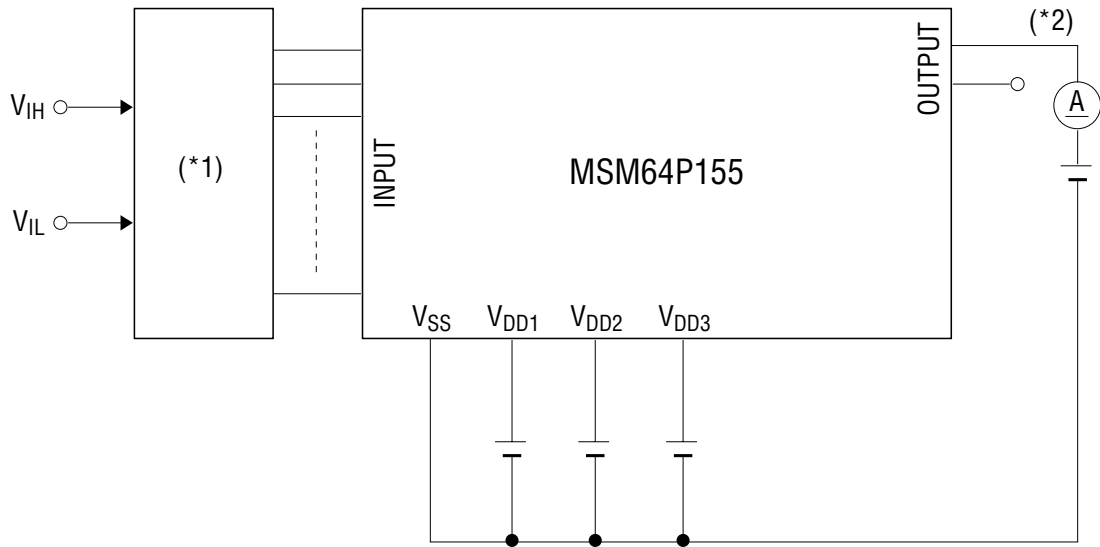

Measuring circuit 3

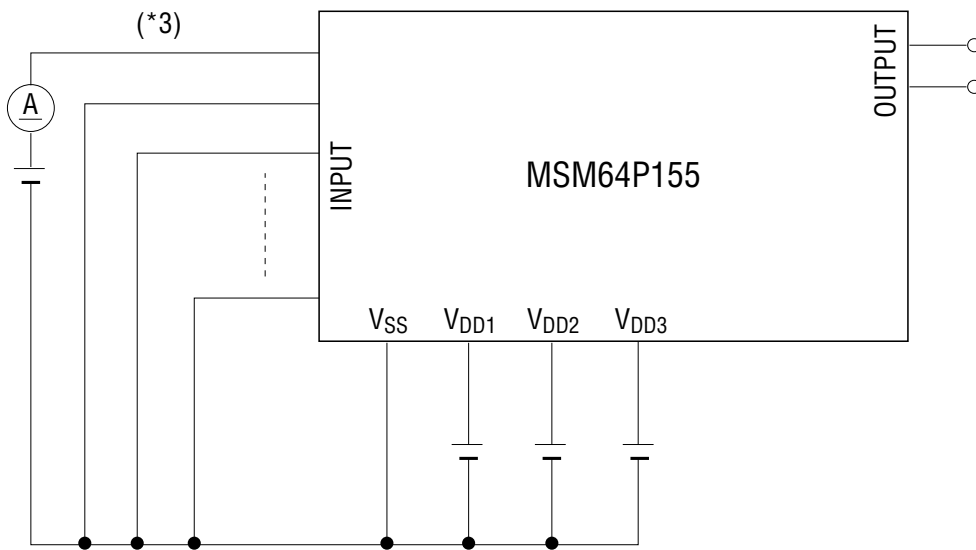



Measuring circuit 4

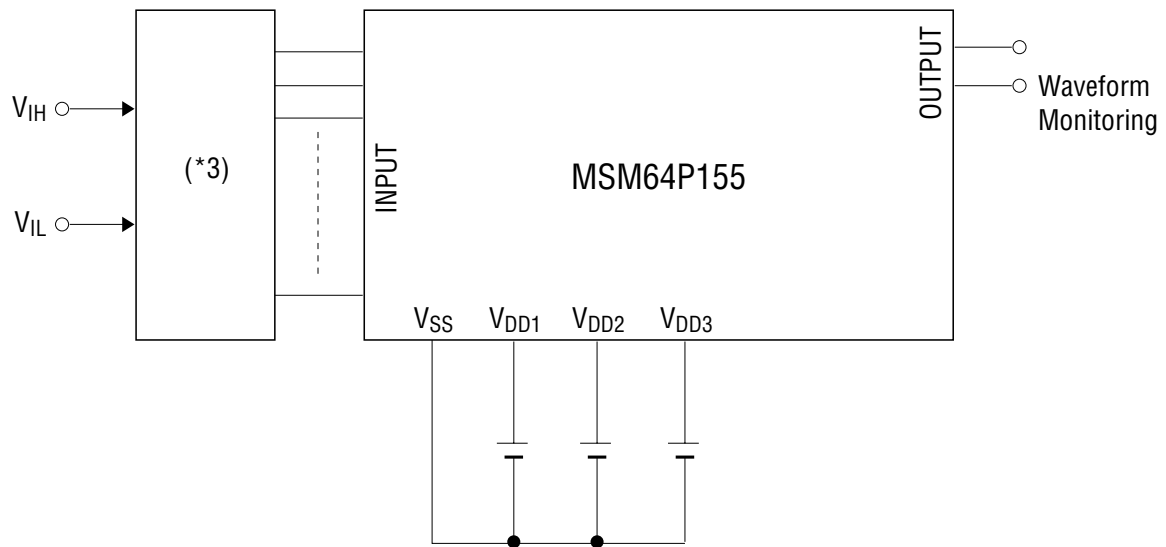

\*1 Input logic circuit to determine the specified measuring conditions.

\*2 Measured at the specified output pins.

\*3 Measured at the specified input pins.

**(2) For 3.0 V Specifications in the Microcontroller Operation Mode**  
**Product Name: MSM64P155L**

**ABSOLUTE MAXIMUM RATINGS**

(V<sub>SS</sub> = 0 V)

Parameter	Symbol	Condition	Rating	Unit
Power Supply Voltage 1	V <sub>DD1</sub>	T <sub>a</sub> = 25°C	-0.3 to +2.0	V
Power Supply Voltage 2	V <sub>DD2</sub>	T <sub>a</sub> = 25°C	-0.3 to +4.0	V
Power Supply Voltage 3	V <sub>DD3</sub>	T <sub>a</sub> = 25°C	-0.3 to +5.5	V
Input Voltage 1	V <sub>IN1</sub>	V <sub>DD2</sub> input, T <sub>a</sub> = 25°C	-0.3 to V <sub>DD2</sub> + 0.3	V
Output Voltage 1	V <sub>OUT1</sub>	V <sub>DD2</sub> output, T <sub>a</sub> = 25°C	-0.3 to V <sub>DD2</sub> + 0.3	V
Output Voltage 2	V <sub>OUT2</sub>	V <sub>DD3</sub> output, T <sub>a</sub> = 25°C	-0.3 to V <sub>DD3</sub> + 0.3	V
Storage Temperature	T <sub>STG</sub>	—	-55 to +150	°C

**RECOMMENDED OPERATING CONDITIONS**

(V<sub>SS</sub> = 0 V)

Parameter	Symbol	Condition	Range	Unit
Operating Temperature	T <sub>OP</sub>	—	0 to +65	°C
Operating Voltage	V <sub>DD2</sub>	—	2.7 to 3.5	V
Crystal Oscillation Frequency	f <sub>XT</sub>	—	30 to 66	kHz
External RC Oscillator Resistance	R <sub>OS</sub>	—	1M ±10%	Ω

## ELECTRICAL CHARACTERISTICS

### DC Characteristics

( $V_{SS} = 0\text{ V}$ ,  $V_{DD2} = 3.0\text{ V}$ ,  $T_a = 0\text{ to }+65^\circ\text{C}$  unless otherwise specified)

Parameter	Symbol	Condition	Min.	Typ.	Max.	Unit	Measuring Circuit
$V_{DD1}$ Voltage	$V_{DD1}$	$C_a = 1\ \mu\text{F}$ $C_b, C_{12} = 0.1\ \mu\text{F}$	1.3	1.5	1.7	V	1a
$V_{DD3}$ Voltage	$V_{DD3}$	$C_a = 1\ \mu\text{F}$ $C_b, C_{12} = 0.1\ \mu\text{F}$	4.3	4.5	4.7	V	
Crystal Oscillation Start Voltage	$V_{STA}$	Oscillation start time: within 5 seconds	2.7	—	—	V	
Crystal Oscillation Hold Voltage	$V_{HOLD}$	—	2.7	—	—	V	
External Crystal Oscillator Capacitance	$C_G$	—	10	—	30	pF	
Internal Crystal Oscillator Capacitance	$C_D$	—	10	15	20	pF	
RC Oscillation Frequency	$f_{CR}$	$R_{OS} = 1\ \text{M}\Omega$	15	40	75	kHz	

### DC Characteristics (32.768 kHz Crystal Oscillation)

( $V_{SS} = 0\text{ V}$ ,  $V_{DD2} = 3.0\text{ V}$ ,  $T_a = 0\text{ to }+65^\circ\text{C}$  unless otherwise specified)

Parameter	Symbol	Condition	Min.	Typ.	Max.	Unit	Measuring Circuit
Supply Current 1	$I_{DD1}$	CPU in the HALT mode	—	1.0	5.0	$\mu\text{A}$	1a
Supply Current 2	$I_{DD2}$	CPU in the operating mode	—	35	50	$\mu\text{A}$	

### DC Characteristics (RC Oscillation)

( $V_{SS} = 0\text{ V}$ ,  $V_{DD2} = 3.0\text{ V}$ ,  $T_a = 0\text{ to }+65^\circ\text{C}$  unless otherwise specified)

Parameter	Symbol	Condition	Min.	Typ.	Max.	Unit	Measuring Circuit
Supply Current 1	$I_{DD1}$	CPU in the HALT mode	—	3.0	15	$\mu\text{A}$	1b
Supply Current 2	$I_{DD2}$	CPU in the operating mode	—	50	100	$\mu\text{A}$	

**DC Characteristics (continued)**

( $V_{SS} = 0\text{ V}$ ,  $V_{DD1} = 1.5\text{ V}$ ,  $V_{DD2} = 3.0\text{ V}$ ,  $V_{DD3} = 4.5\text{ V}$ ,  $T_a = 0\text{ to }+65^\circ\text{C}$  unless otherwise specified)

Parameter	Symbol	Condition	Min.	Typ.	Max.	Unit	Measuring Circuit
Output Current 1 (P4.0 to P4.3) (MD0, MD0) (MD1, MD1)	$I_{OH1}$	$V_{OH1} = V_{DD2} - 0.5\text{ V}$	-6.0	-2.0	-0.7	mA	2
	$I_{OL1}$	$V_{OL1} = +0.5\text{ V}$	0.7	2.0	6.0	mA	
Output Current 2 (SEG0 to SEG59) (COM1 to COM4)	$I_{OH2}$	$V_{OH2} = V_{DD3} - 0.2\text{ V}$ ( $V_{DD3}$ level)	—	—	-4.0	$\mu\text{A}$	
	$I_{OMH2}$	$V_{OMH2} = V_{DD2} + 0.2\text{ V}$ ( $V_{DD2}$ level)	4.0	—	—	$\mu\text{A}$	
	$I_{OMH2S}$	$V_{OMH2S} = V_{DD2} - 0.2\text{ V}$ ( $V_{DD2}$ level)	—	—	-4.0	$\mu\text{A}$	
	$I_{OML2}$	$V_{OML2} = V_{DD1} + 0.2\text{ V}$ ( $V_{DD1}$ level)	4.0	—	—	$\mu\text{A}$	
	$I_{OML2S}$	$V_{OML2S} = V_{DD1} - 0.2\text{ V}$ ( $V_{DD1}$ level)	—	—	-4.0	$\mu\text{A}$	
Output Current 3 (P6.0 to P6.3) (P7.0 to P7.3)	$I_{OH3}$	$V_{OH3} = V_{DD2} - 0.5\text{ V}$	-18	-6.0	-2.0	mA	
	$I_{OL3}$	$V_{OL3} = +0.5\text{ V}$	0.7	1.6	6.0	mA	
Output Leakage Current (P6.0 to P6.3) (P7.0 to P7.3)	$I_{OOH}$	$V_{OH} = V_{DD2}$	—	—	0.3	$\mu\text{A}$	
	$I_{OOL}$	$V_{OL} = V_{SS}$	-0.3	—	—	$\mu\text{A}$	
Input Current 1 (P2.0 to P2.3) (P3.0, P3.1) (P6.0 to P6.3) (P7.0 to P7.3)	$I_{IH1}$	$V_{IH1} = V_{DD2}$ (when pulled down)	50	100	300	$\mu\text{A}$	3
	$I_{IH1Z}$	$V_{IH1} = V_{DD2}$ (in a high impedance state)	0	—	1.0	$\mu\text{A}$	
	$I_{IL1}$	$V_{IL1} = V_{SS}$	-1.0	—	0	$\mu\text{A}$	
Input Current 2 (TST1, TST2)	$I_{IH2}$	$V_{IH2} = V_{DD2}$	0.75	1.5	3.0	mA	
	$I_{IL2}$	$V_{IL2} = V_{SS}$	-1.0	—	0	$\mu\text{A}$	
Input Current 3 (TST3)	$I_{IH3}$	$V_{IH3} = V_{DD2}$	20	80	200	$\mu\text{A}$	
	$I_{IL3}$	$V_{IL3} = V_{SS}$	-1.0	—	0	$\mu\text{A}$	
Input Current 4 (RESET)	$I_{IH4}$	$V_{IH4} = V_{DD2}$	40	80	200	$\mu\text{A}$	
	$I_{IL4}$	$V_{IL4} = V_{SS}$	-1.0	—	0	$\mu\text{A}$	
Input Voltage 1 (P2.0 to P2.3) (P3.0, P3.1) (P6.0 to P6.3) (P7.0 to P7.3) (TST1, TST2, TST3) (RESET)	$V_{IH1}$	—	2.4	—	3.0	V	4
	$V_{IL1}$	—	0	—	0.6	V	

Measuring circuit 1a

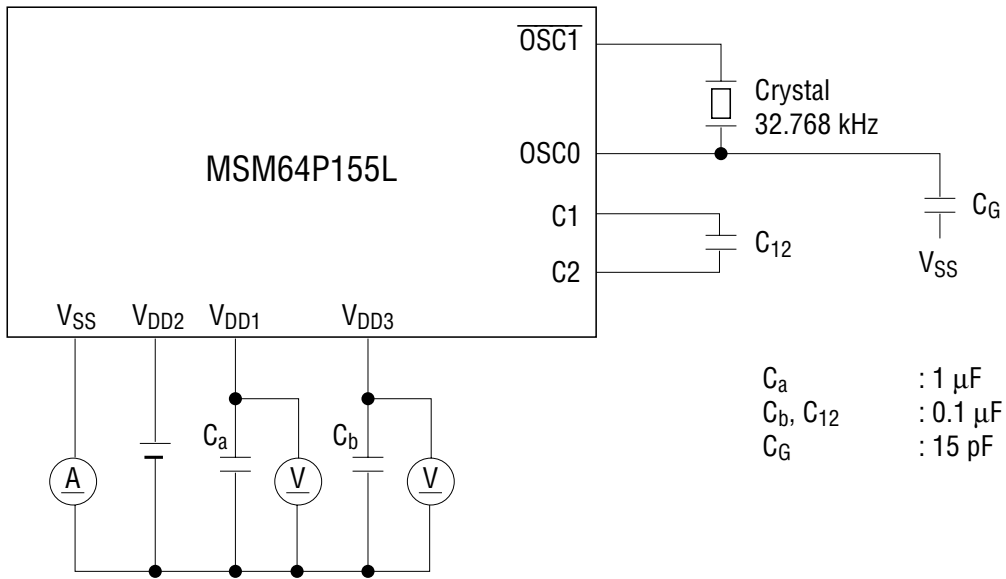

Measuring circuit 1b

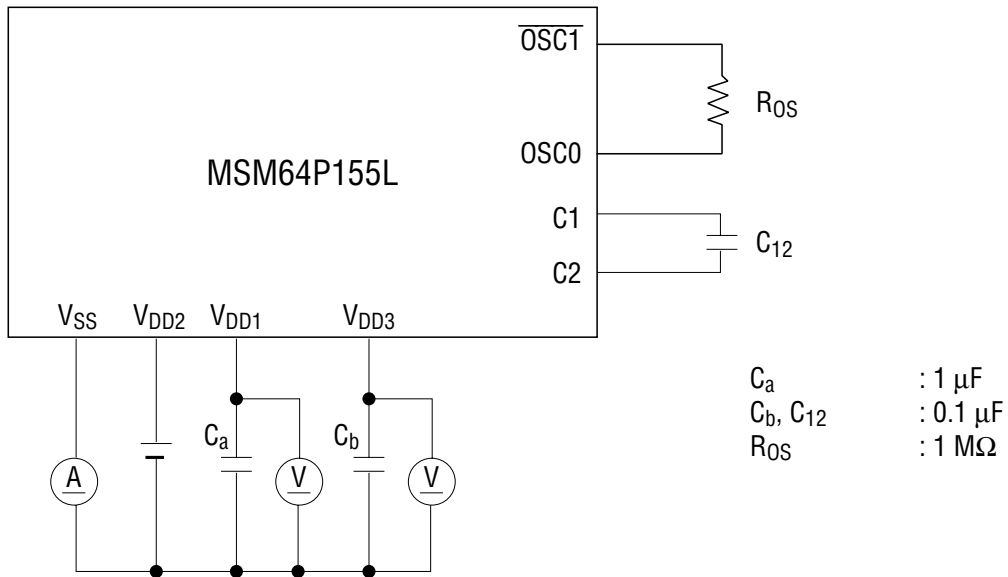

Measuring circuit 2

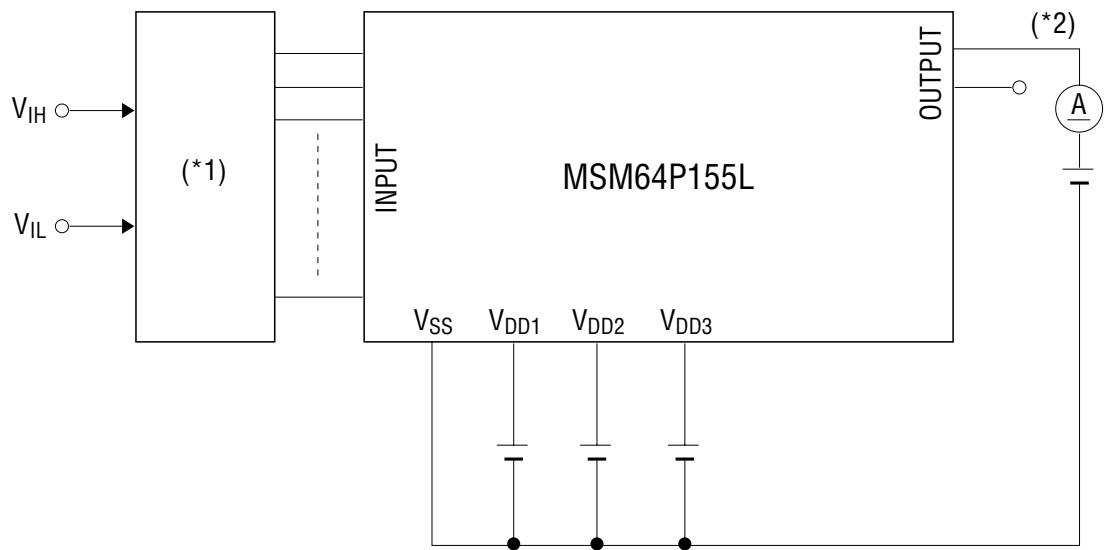

Measuring circuit 3

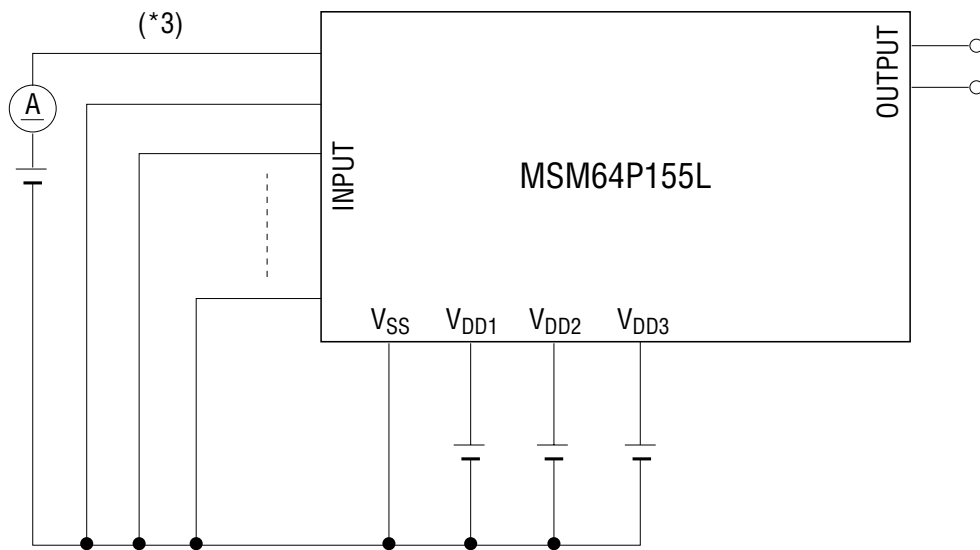

Measuring circuit 4

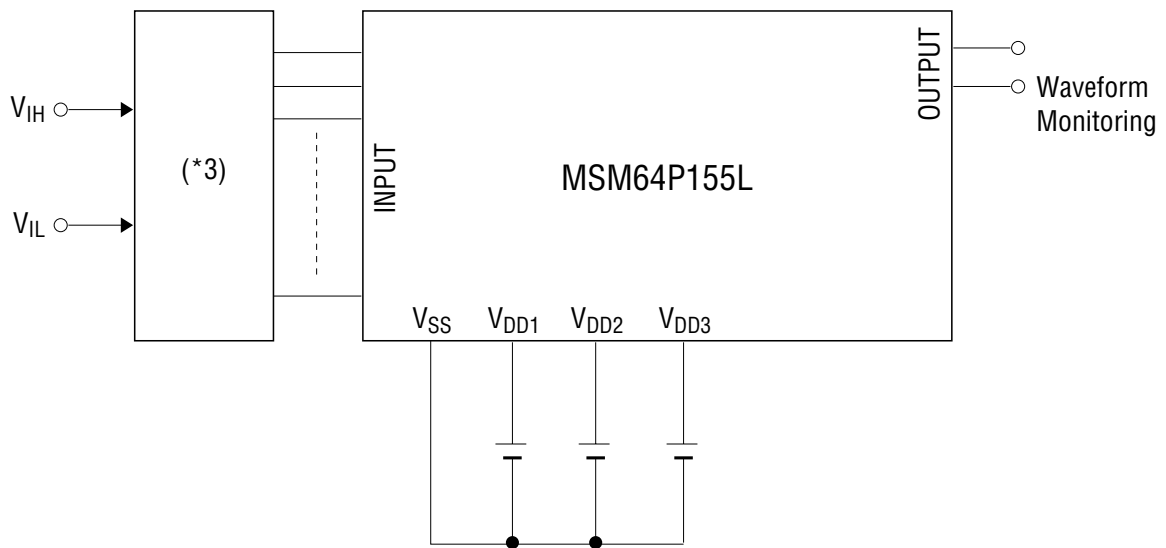

\*1 Input logic circuit to determine the specified measuring conditions.

\*2 Measured at the specified output pins.

\*3 Measured at the specified input pins.

**(3) PROM Operations (Common to 1.5 V and 3.0 V Specifications)****ABSOLUTE MAXIMUM RATINGS**(V<sub>SS</sub> = 0 V)

Parameter	Symbol	Condition	Rating	Unit
PROM Power Source Voltage	V <sub>CC</sub>	V <sub>CC</sub> = V <sub>DD1</sub> = V <sub>DD2</sub> Ta = 25°C	-0.3 to +6.7	V
Program Voltage	V <sub>PP</sub>	Ta = 25°C	-0.3 to +14.0	V
PROM Input Voltage	V <sub>I</sub>	V <sub>CC</sub> input Ta = 25°C	-0.3 to V <sub>CC</sub> + 0.3	V
PROM Output Voltage	V <sub>O</sub>	V <sub>CC</sub> output Ta = 25°C	V <sub>SS1</sub> - 0.3 to +0.3	V
Storage Temperature	T <sub>STG</sub>	—	-55 to +150	°C

**RECOMMENDED OPERATING CONDITIONS**(V<sub>SS</sub> = 0 V)

Parameter	Symbol	Condition	Range	Unit
Operating Temperature	T <sub>op</sub>	—	0 to +65	°C
V <sub>CC</sub> Power Supply Voltage	V <sub>CC</sub>	V <sub>CC</sub> = V <sub>DD1</sub> = V <sub>DD2</sub>	4.75 to 5.25	V
V <sub>PP</sub> Power Supply Voltage	V <sub>PP</sub>	When data is read	4.75 to 5.25	V
		When data is written	12.0 to 13.0	V
Input Voltage	V <sub>IH</sub>	V <sub>CC</sub> = V <sub>DD1</sub> = V <sub>DD2</sub>	4.0 to V <sub>CC</sub>	V
	V <sub>IL</sub>	—	0 to 1.0	V



## ELECTRICAL CHARACTERISTICS

### (1) Read Operation

#### DC Characteristics

( $V_{DD1} = V_{DD2} = V_{PP} = 5\text{ V} \pm 5\%$ ,  $T_a = 25^\circ\text{C} \pm 5^\circ\text{C}$  unless otherwise specified)

Parameter	Symbol	Condition	Min.	Typ.	Max.	Unit
$V_{CC}$ Supply Voltage (Standby)	$I_{CC1}$	$V_{CC} = V_{DD1} = V_{DD2}$ $\overline{CE} = V_{IH}$	—	—	35	mA
$V_{CC}$ Supply Voltage (Operating)	$I_{CC2}$	$V_{CC} = V_{DD1} = V_{DD2}$ $\overline{CE} = V_{IL}$	—	—	100	mA
Input Voltage	$V_{IH}$	$V_{CC} = V_{DD1} = V_{DD2}$	4.0	—	$V_{CC}$	V
	$V_{IL}$	—	0	—	1.0	V
Output Current	$I_{OH}$	$V_{CC} = V_{DD1} = V_{DD2}$ $V_{OH} = V_{CC} - 0.5\text{ V}$	-2	-0.7	-0.2	mA
	$I_{OL}$	$V_{OL} = 0.5\text{ V}$	0.2	0.7	2	mA

#### AC Characteristics

( $V_{CC} = 5\text{ V} \pm 5\%$ ,  $V_{PP} = V_{CC}$ ,  $T_a = 0\text{ to }+65^\circ\text{C}$  unless otherwise specified)

Parameter	Symbol	Condition	Min.	Typ.	Max.	Unit
Address Access Time	$t_{ACC}$	$\overline{OE} = \overline{CE} = V_{IL}$	—	—	120	ns
$\overline{CE}$ Access Time	$t_{CE}$	$\overline{OE} = V_{IL}$	—	—	120	ns
$\overline{OE}$ Access Time	$t_{OE}$	$\overline{CE} = V_{IL}$	—	—	50	ns
Output Disable Time	$t_{DF}$	$\overline{CE} = V_{IL}$	0	—	40	ns

#### Measurement Conditions:

Input pulse level ..... 0.45 V to 4.55 V

Input rise/fall time ..... 5 ns

Threshold level ..... input 0.8 V, 2 V/output 0.8 V, 2 V

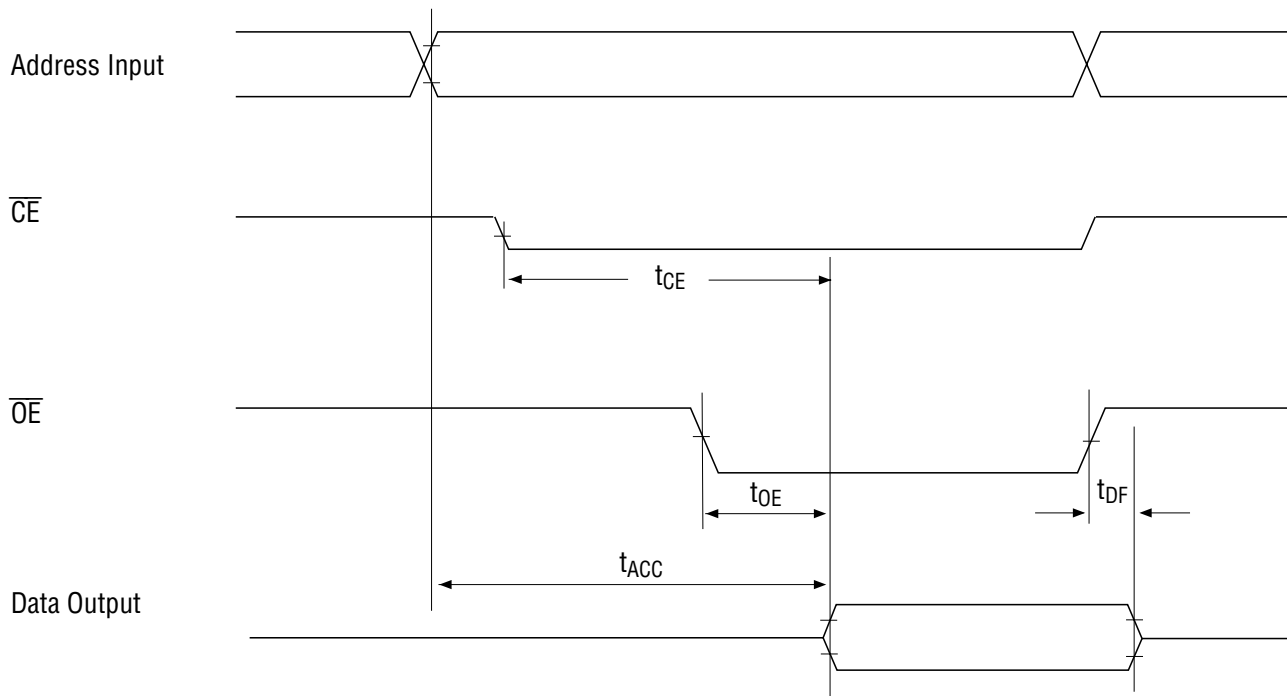

## (2) Write Operation

**DC Characteristics**(V<sub>SS</sub> = 0 V, V<sub>DD1</sub> = V<sub>DD2</sub> = 5 V ±5%, V<sub>PP</sub> = 12.5 V ±0.5 V, T<sub>a</sub> = 25°C ±5°C unless otherwise specified)

Parameter	Symbol	Condition	Min.	Typ.	Max.	Unit
V <sub>PP</sub> Power Supply Current	I <sub>PP</sub>	$\overline{CE} = V_{IL}$	—	—	50	mA
V <sub>CC</sub> Power Supply Current	I <sub>CC</sub>	V <sub>CC</sub> = V <sub>DD1</sub> = V <sub>DD2</sub>	—	—	100	mA
Input Voltage	V <sub>IH</sub>	V <sub>CC</sub> = V <sub>DD1</sub> = V <sub>DD2</sub>	4.0	—	V <sub>CC</sub>	V
	V <sub>IL</sub>	—	0	—	1.0	V
Output Current	I <sub>OH</sub>	V <sub>CC</sub> = V <sub>DD1</sub> = V <sub>DD2</sub> V <sub>OH</sub> = V <sub>CC</sub> - 0.5 V	-2.0	-0.7	-0.2	mA
	I <sub>OL</sub>	V <sub>OL</sub> = 0.5 V	0.2	0.7	2.0	mA

**AC Characteristics**(V<sub>SS</sub> = 0 V, V<sub>DD1</sub> = V<sub>DD2</sub> = 5 V ±5%, V<sub>PP</sub> = 12.5 V ±0.5 V, T<sub>a</sub> = 25°C ±5°C unless otherwise specified)

Parameter	Symbol	Condition	Min.	Typ.	Max.	Unit
Address Setup Time	t <sub>AS</sub>	—	2.0	—	—	μs
$\overline{OE}$ Setup Time	t <sub>OES</sub>	—	2.0	—	—	μs
Data Setup Time	t <sub>DS</sub>	—	2.0	—	—	μs
Address Hold Time	t <sub>AH</sub>	—	0	—	—	μs
Data Hold Time	t <sub>DH</sub>	—	2.0	—	—	μs
$\overline{OE}$ Output Floating Delay Time	t <sub>DFP</sub>	—	0	—	130	ns
V <sub>PP</sub> Power Source Setup Time	t <sub>VS</sub>	—	2.0	—	—	μs
Initial Program Pulse Width	t <sub>PW</sub>	V <sub>DD1</sub> = V <sub>DD2</sub> 6 V ±0.25 V	0.95	1.0	1.05	ms
Additional Program Pulse Width	t <sub>OPW</sub>	V <sub>DD1</sub> = V <sub>DD2</sub> 6 V ±0.25 V	2.85	—	78.75	ms
$\overline{OE}$ Output Effective Delay Time	t <sub>OE</sub>	—	—	—	150	ns

## Measurement Conditions:

Input pulse level ..... 0.45 V to 4.55 V

Input rise/fall time ..... less than 20 ns

Threshold level ..... input 0.8 V, 2 V/output 0.8 V, 2 V

