

MSM6597A-xxx

3-Mbit Serial Voice ROM

GENERAL DESCRIPTION

The MSM6597A is a MSM6597 short TAT process version.

The MSM6597A is a serial voice ROM with a 1,048,576-word × 1-bit × 3-bank configuration.

The MSM6597A has a built-in internal address-generating circuit. A single, external clock input allows continuous, serial read operations. The internal addresses are automatically incremented by 1 by read operation. 1024 words in X direction and 1024 words in Y direction can be addressed by inputting external serial addresses. Banks are switched with $\overline{CS1}$, $\overline{CS2}$, and $\overline{CS3}$.

A read and playback device with predetermined messages can easily be configured by storing voice data into the MSM6597A and by combining it with one of Oki's recording and playback ICs and with one of Oki's serial registers.

A serial register is required to drive the MSM6597A when used with the MSM6388 or MSM6588. (The MSM6597A does not operate without a serial register.)

The major differences between the MSM6597A and MSM6597 are shown below.

MSM6597A DC Characteristics

 $V_{DD} = 3.5 \text{ to } 5.5 \text{ V}, T_a = -40 \text{ to } +85^\circ\text{C}$

Parameter	Symbol	Condition	Min.	Typ.	Max.	Unit	
Current Consumption (1)	I_{DD}	$t_{RDC} = 2.5 \mu\text{s}$	—	9	20	mA	
Current Consumption (2)	I_{DS}	$\overline{CS1} = \overline{CS2} = \overline{CS3} = V_{DD} - 0.2 \text{ V}$	$T_a = -40 \text{ to } +70^\circ\text{C}$	—	—	10	μA
			$T_a = -40 \text{ to } +85^\circ\text{C}$	—	—	50	

MSM6597 DC Characteristics

 $V_{DD} = 3.5 \text{ to } 5.5 \text{ V}, T_a = -40 \text{ to } +85^\circ\text{C}$

Parameter	Symbol	Condition	Min.	Typ.	Max.	Unit
Current Consumption (1)	I_{DD}	$t_{RDC} = 2.5 \mu\text{s}$	—	—	15	mA
Current Consumption (2)	I_{DS}	$\overline{CS1} = \overline{CS2} = \overline{CS3} = V_{DD} - 0.2 \text{ V}$	—	—	10	μA

Typical values are at $V_{DD} = 5.0 \text{ V}, T_a = 25^\circ\text{C}$

For other details, refer to individual sections in this data sheet.

FEATURES

- Configuration : 1,048,576 words × 1 bit × 3 banks
- Serial access : Read cycle time of 2.5 μs
- Shorter-TAT processing
- Power-supply voltage : 5 V single supply
- Package options :
 - 24-pin plastic SOP (SOP24-P-430-1.27-K) (Product name : MSM6597A-xxxGS-K)
 - 30-pin plastic SSOP (SSOP30-P-56-0.65-K) (Product name : MSM6597A-xxxGS-AK)

BLOCK DIAGRAM

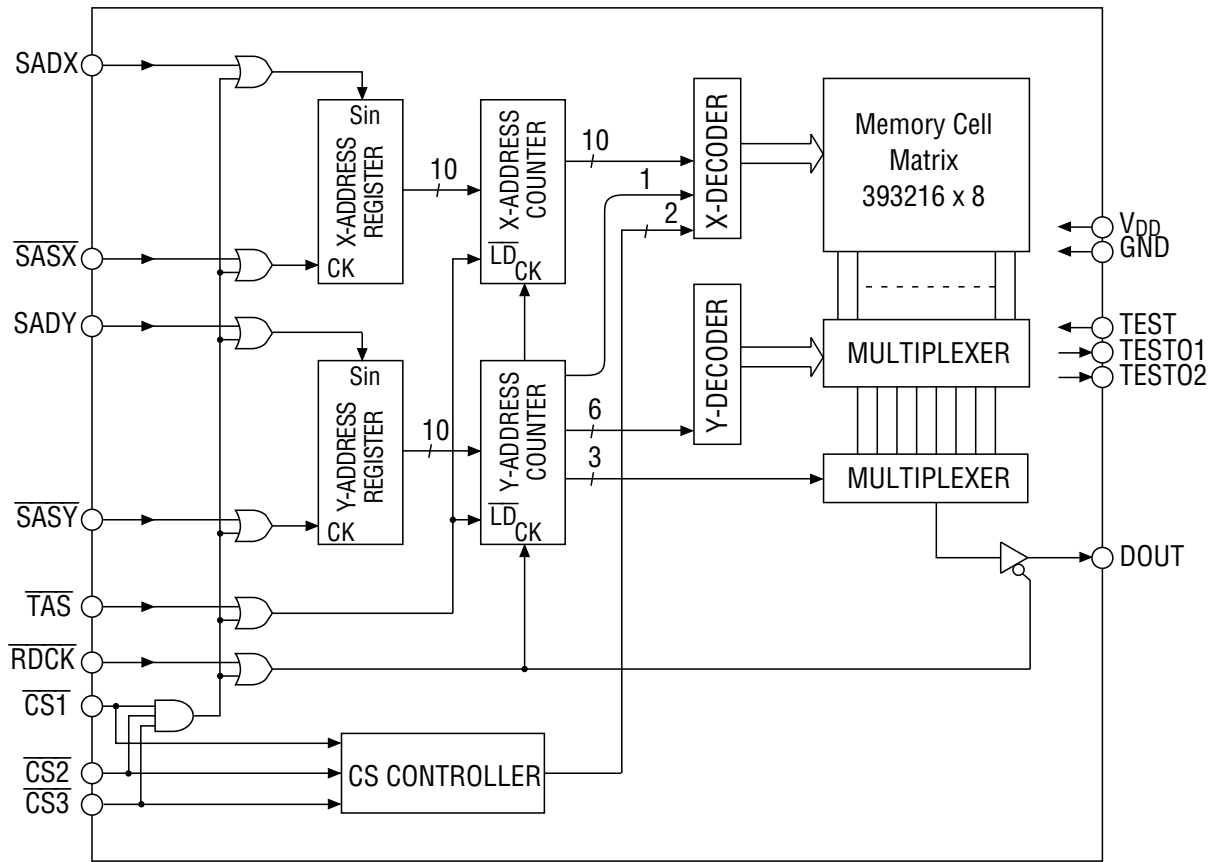

PIN CONFIGURATION (TOP VIEW)

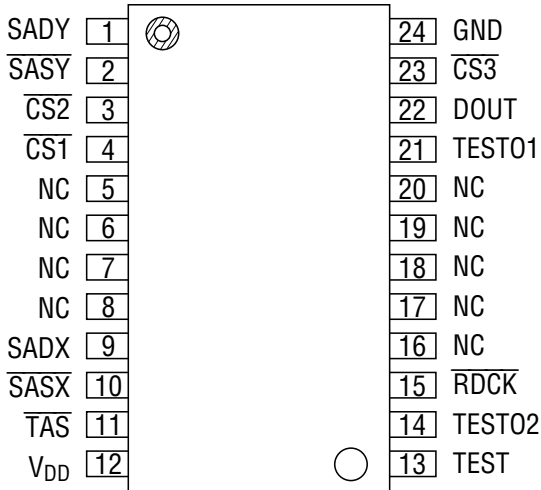

NC : No connection

24-Pin Plastic SOP

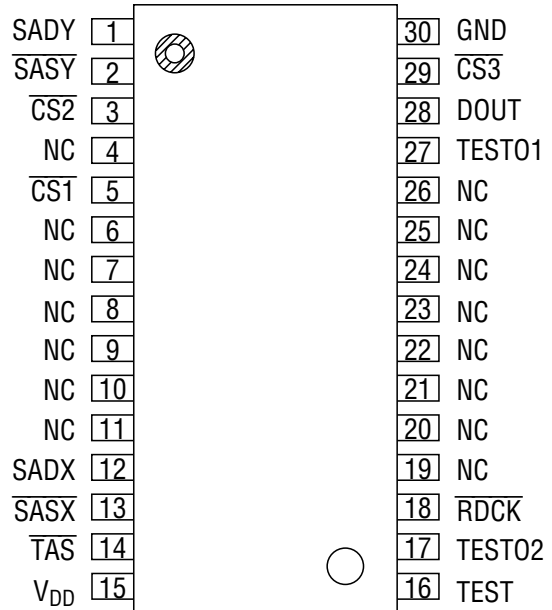

NC : No connection

30-Pin Plastic SSOP

PIN DESCRIPTIONS

Pin		Symbol	Type	Description
SOP	SSOP			
12	15	V _{DD}	—	Power supply pin. Insert a bypass capacitor of 0.1 μF or more between this pin and the GND pin.
24	30	GND	—	Ground pin
9	12	SADX	I	(SERIAL ADDRESS) This pin inputs the starting X address of a read operation. Addressing in units of 1024 words is possible. The 1024-word address data can be input as 10-bit (AX0 - AX9) serial data via the SADX pin.
1	1	SADY	I	(SERIAL ADDRESS) This pin inputs the starting Y address of a read operation. Addressing in units of 1024 words is possible. The 1024-word address data can be input as 10-bit (AY0 - AY9) serial data via the SADY pin.
10	13	$\overline{\text{SASX}}$	I	(SERIAL ADDRESS STROBE) This is the clock input pin which is used to store the serial address data of the X address into the device's internal register.
2	2	$\overline{\text{SASY}}$	I	(SERIAL ADDRESS STROBE) This is the clock input pin which is used to store the serial address data of the Y address into the device's internal register.
11	14	$\overline{\text{TAS}}$	I	(ADDRESS TRANSFER STROBE) This is the input pin for loading the serial address data into the internal address counter. The X and Y addresses are stored at the falling edge of $\overline{\text{TAS}}$.
15	18	$\overline{\text{RDCK}}$	I	(READ CLOCK) This is the clock input pin for reading information out of the data register. Internal operation starts at the falling edge of $\overline{\text{RDCK}}$. The information in the data register is output on the DOUT pin. The internal address counter is automatically incremented by 1 at the falling edge of $\overline{\text{RDCK}}$.
22	28	DOUT	O	(DATA OUT) The data output pin is always kept in a high-impedance state when $\overline{\text{CS1}}$, $\overline{\text{CS2}}$, and $\overline{\text{CS3}}$ are all kept "H" or when $\overline{\text{RDCK}}$ is kept "H". This pin reflects the "H" or "L" level data being read, and the current data is hold until $\overline{\text{RDCH}}$ is asserted High.
4	5	$\overline{\text{CS1}}$	I	(CHIP SELECT) When either $\overline{\text{CS1}}$, $\overline{\text{CS2}}$, or $\overline{\text{CS3}}$ is "L", bank 1, bank 2, or bank 3 is selected, respectively. Setting all three signals "H" disables all input and output pins. These pins enable parallel use of multiple serial voice ROMs by connecting the data output pins.
3	3	$\overline{\text{CS2}}$		
23	29	$\overline{\text{CS3}}$		
13	16	TEST	I	Pin for testing. Apply "L" level.
21	27	TEST01	O	Pins for testing. Leave these pins open.
14	17	TEST02		

ABSOLUTE MAXIMUM RATINGS

Parameter	Symbol	Condition	Rating	Unit
Power Supply Voltage	V _{DD}	T _a = 25°C	-0.3 to +7.0	V
Input Voltage	V _{IN}	T _a = 25°C	-0.3 to V _{DD} +0.3	V
Storage Temperature	T _{STG}	—	-55 to +150	°C

RECOMMENDED OPERATING CONDITIONS

Parameter	Symbol	Condition	Range	Unit
Power Supply Voltage	V _{DD}	GND=0V	3.5 to 5.5	V
Operating Temperature	T _{op}	—	-40 to +85	°C

ELECTRICAL CHARACTERISTICS

DC Characteristics

V_{DD} = 3.5 to 5.5 V, Ta = -40 to +85°C

Parameter	Symbol	Condition	Min.	Typ.	Max.	Unit	
"H" Level Input Voltage	V _{IH}	—	0.8xV _{DD}	—	—	V	
"L" Level Input Voltage	V _{IL}	—	—	—	0.8	V	
"H" Level Output Voltage	V _{OH}	I _{OH} = -40 μA	V _{DD} -0.3	—	—	V	
"L" Level Output Voltage	V _{OL}	I _{OL} = 2 mA	—	—	0.45	V	
"H" Level Input Current	I _{IH}	V _{IH} = V _{DD}	—	—	10	μA	
"L" Level Input Current	I _{IL}	V _{IL} = GND	-10	—	—	μA	
Current Consumption (1)	I _{DD}	t _{RDC} = 2.5 μs	—	9	20	mA	
Current Consumption (2)	I _{DS}	CS1 = CS2 = CS3 = V _{DD} - 0.2 V	Ta = -40 to +70°C	—	—	10	μA
			Ta = -40 to +85°C	—	—	50	

Typical values are at V_{DD} = 5.0 V, Ta = 25°C

AC Characteristics

V_{DD} = 3.5 to 5.5 V, Ta = -40 to +85°C

Parameter	Symbol	Min.	Max.	Unit
CS, SAS Setup Time	t _{CSS}	1000	—	ns
SASX, SASY Cycle Time	t _{SSC}	500	—	ns
SASX, SASY Precharge Time	t _{SAP}	250	—	ns
SASX, SASY Pulse Width	t _{SAS}	250	—	ns
Address Setup Time	t _{AS}	100	—	ns
Address Hold Time	t _{AH}	100	—	ns
TAS Setup Time	t _{ATS}	500	—	ns
TAS, RDCK Setup Time	t _{TRS}	500	—	ns
TAS Pulse Width	t _{TAS}	250	—	ns
Read Cycle Time	t _{RDC}	2500	—	ns
Access Time	t _{ACC}	—	1500	ns
Output Turn-off Delay Time	t _{OFF}	0	200	ns
RDCK Precharge Time	t _{RDP}	1000	—	ns
RDCK Pulse Width	t _{RD}	1500	—	ns

TIMING DIAGRAMS

Serial Address Input Timing

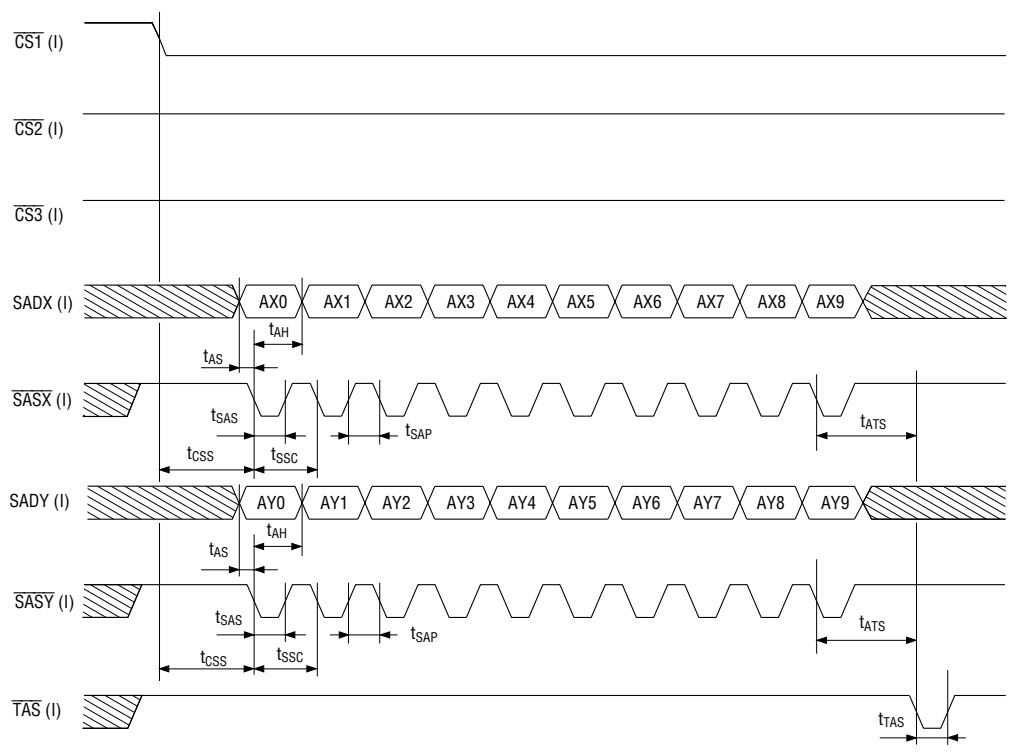

Read Access Timing

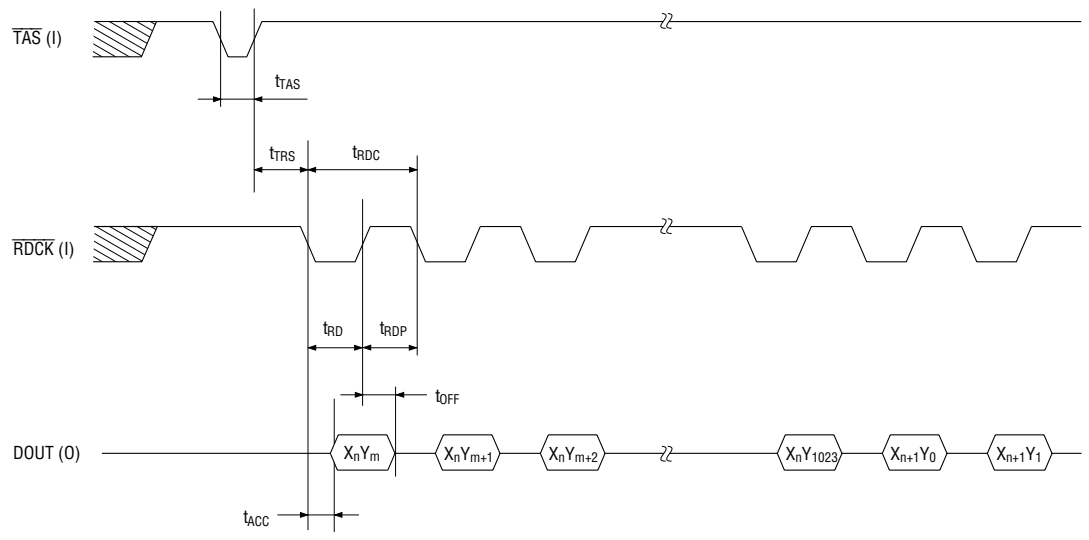

APPLICATION CIRCUIT

MSM6588 Playback Storage Example

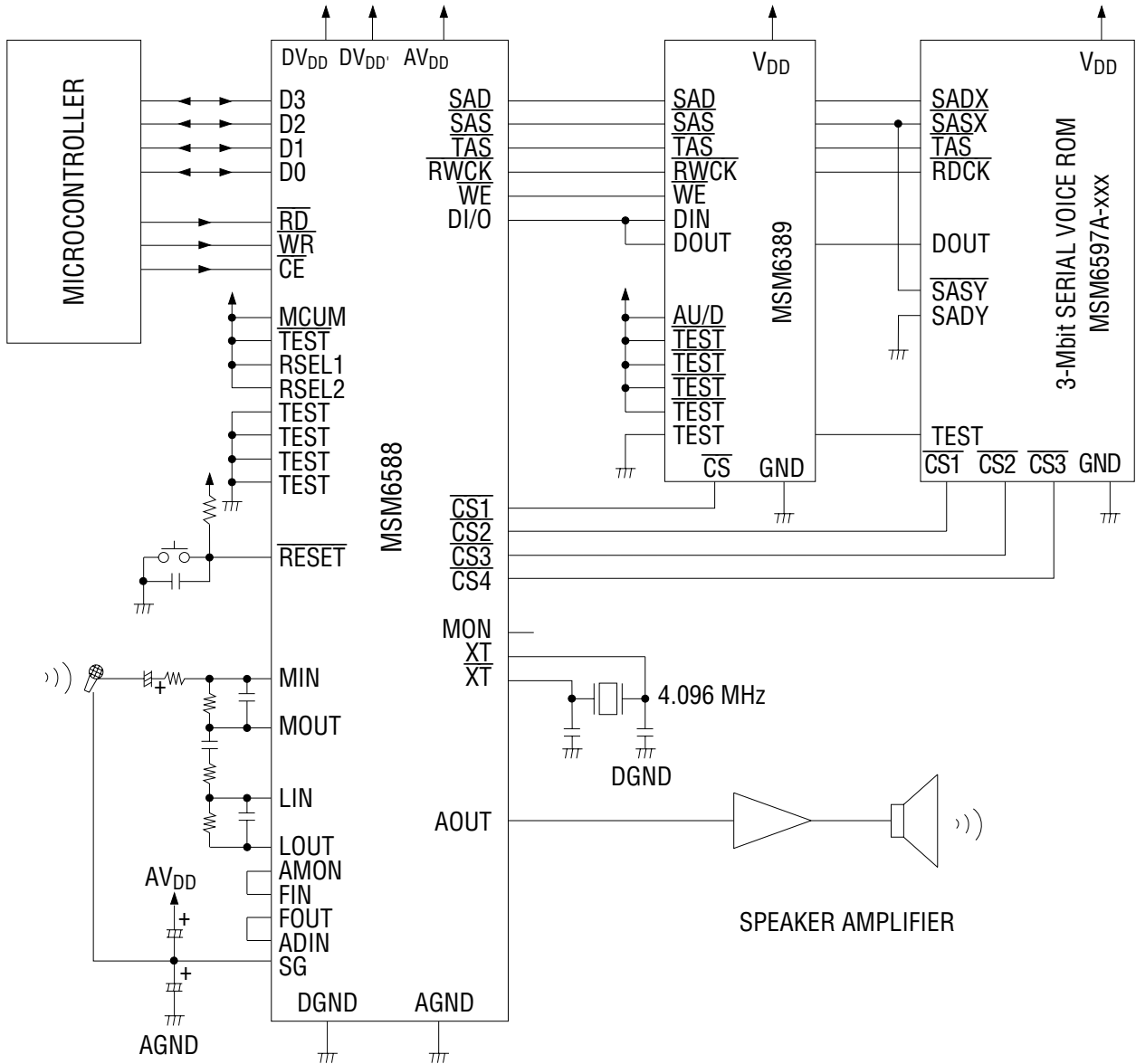

Note: When the MSM6597A is driven by the MSM6388 or MSM6588, a serial register is required. (The MSM6597A does not operate without it.)

PACKAGE DIMENSIONS

(Unit : mm)

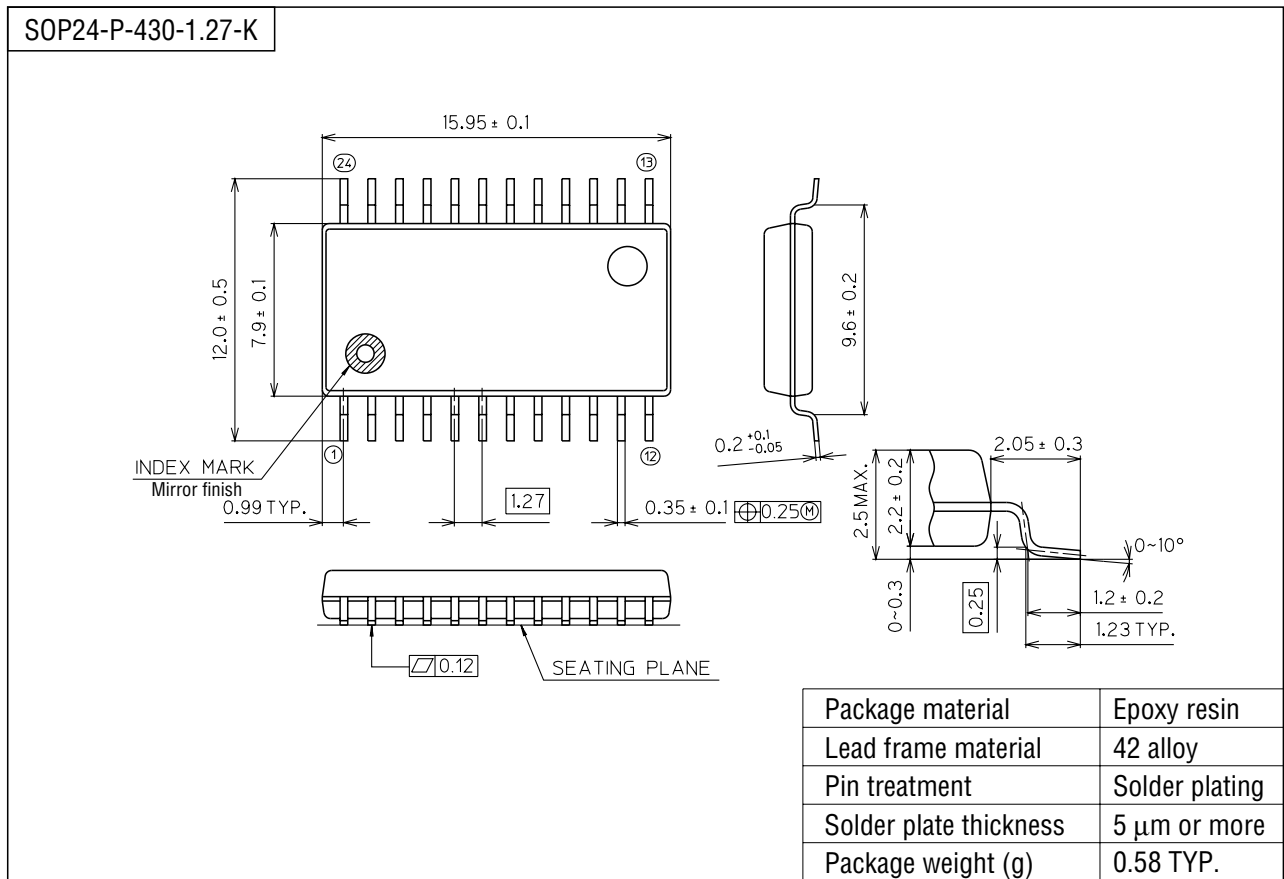

Notes for Mounting the Surface Mount Type Package

The SOP, QFP, TSOP, TQFP, LQFP, SOJ, QFJ (PLCC), SHP, and BGA are surface mount type packages, which are very susceptible to heat in reflow mounting and humidity absorbed in storage. Therefore, before you perform reflow mounting, contact Oki's responsible sales person on the product name, package name, pin number, package code and desired mounting conditions (reflow method, temperature and times).

(Unit : mm)

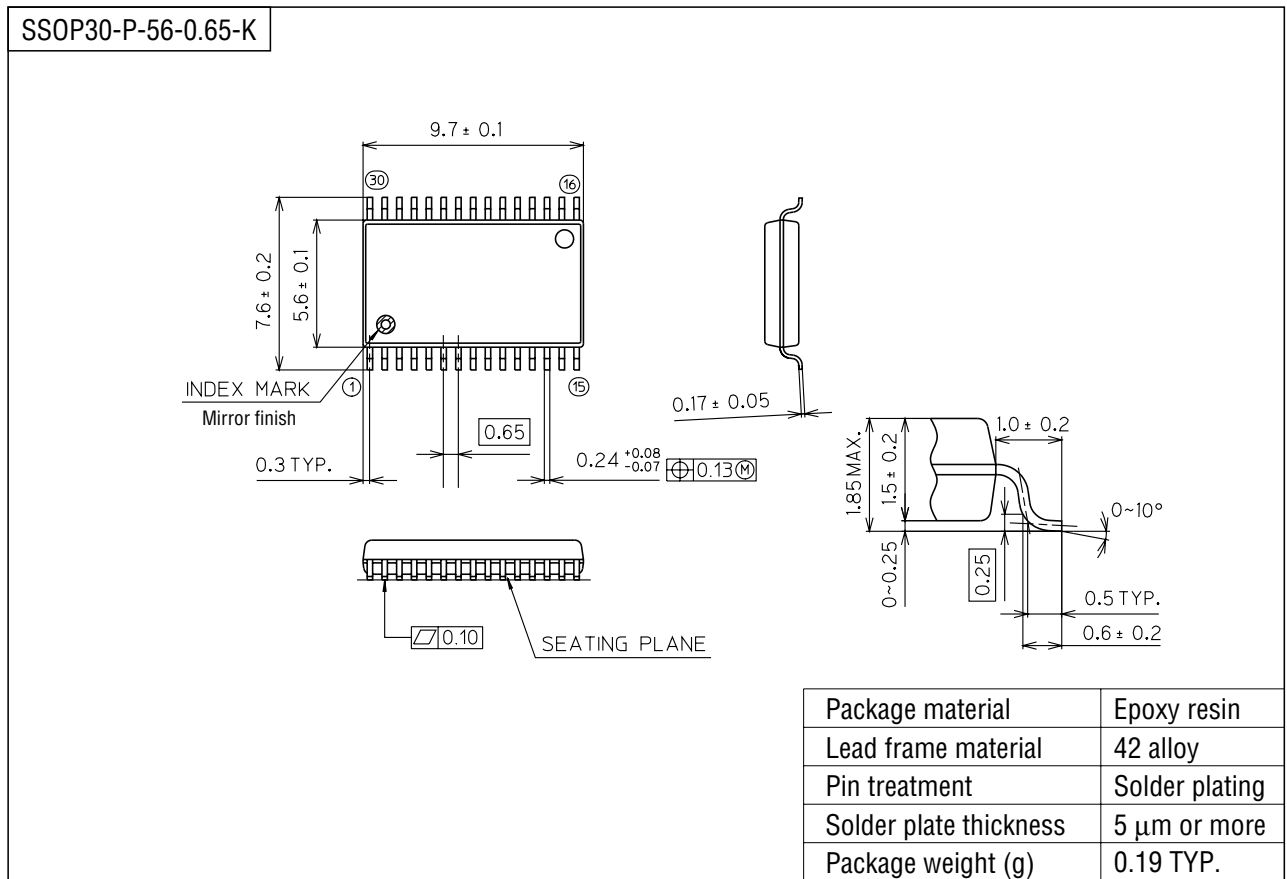

Notes for Mounting the Surface Mount Type Package

The SOP, QFP, TSOP, TQFP, LQFP, SOJ, QFJ (PLCC), SHP, and BGA are surface mount type packages, which are very susceptible to heat in reflow mounting and humidity absorbed in storage. Therefore, before you perform reflow mounting, contact Oki's responsible sales person on the product name, package name, pin number, package code and desired mounting conditions (reflow method, temperature and times).

NOTICE

1. The information contained herein can change without notice owing to product and/or technical improvements. Before using the product, please make sure that the information being referred to is up-to-date.
2. The outline of action and examples for application circuits described herein have been chosen as an explanation for the standard action and performance of the product. When planning to use the product, please ensure that the external conditions are reflected in the actual circuit, assembly, and program designs.
3. When designing your product, please use our product below the specified maximum ratings and within the specified operating ranges including, but not limited to, operating voltage, power dissipation, and operating temperature.
4. Oki assumes no responsibility or liability whatsoever for any failure or unusual or unexpected operation resulting from misuse, neglect, improper installation, repair, alteration or accident, improper handling, or unusual physical or electrical stress including, but not limited to, exposure to parameters beyond the specified maximum ratings or operation outside the specified operating range.
5. Neither indemnity against nor license of a third party's industrial and intellectual property right, etc. is granted by us in connection with the use of the product and/or the information and drawings contained herein. No responsibility is assumed by us for any infringement of a third party's right which may result from the use thereof.
6. The products listed in this document are intended for use in general electronics equipment for commercial applications (e.g., office automation, communication equipment, measurement equipment, consumer electronics, etc.). These products are not authorized for use in any system or application that requires special or enhanced quality and reliability characteristics nor in any system or application where the failure of such system or application may result in the loss or damage of property, or death or injury to humans. Such applications include, but are not limited to, traffic and automotive equipment, safety devices, aerospace equipment, nuclear power control, medical equipment, and life-support systems.
7. Certain products in this document may need government approval before they can be exported to particular countries. The purchaser assumes the responsibility of determining the legality of export of these products and will take appropriate and necessary steps at their own expense for these.
8. No part of the contents contained herein may be reprinted or reproduced without our prior permission.
9. MS-DOS is a registered trademark of Microsoft Corporation.

Copyright 1999 Oki Electric Industry Co., Ltd.