MSM66201/66P201/66207/ 66P207

OLMS-66K Series 16-Bit Microcontroller

GENERAL DESCRIPTION

The MSM66201/66207 is a high performance microcontroller that employs OKI original nX-8/200 CPU core. This chip includes a 16-bit CPU, ROM, RAM, I/O ports, multifunction 16-bit timers, 10-bit A/D converter, serial I/O port, and pulse width modulator (PWM). The MSM66P201/66P207 is the OTP (One-Time Programmable) version of the MSM66201/66207.

FEATURES

- 64K address space for program memory : Internal ROM : MSM66201 16K bytes
MSM66207 32K bytes
- 64K address space for data memory : Internal RAM : MSM66201 512 bytes
MSM66207 1024 bytes
- High-speed execution : 400ns @ 10MHz
Minimum cycle for instruction
- Powerful instruction set : Instruction set superior in orthogonal matrix
8/16-bit data transfer instructions
8/16-bit arithmetic instructions
Multiplication and division operation instructions
Bit manipulation instructions
Bit logic instructions
ROM table reference instructions
- Abundant addressing modes : Register addressing
Page addressing
Pointing register indirect addressing
Stack addressing
Immediate value addressing
- I/O port : 5 ports × 8 bits
Input-output port (Each bit can be assigned to input or output)
Input port : 1 port × 8 bits
- Built-in multifunctional 16-bit timer : 4
Following 4 modes can be set for each timer : Auto-reload timer mode
Clock output mode
Capture register mode
Real time output mode
- Serial port : 1 channel (Synchronous/UART switchable mode with baud rate generators)
- 16-bit pulse width modulator : 2
- Watchdog timer
- Transition detector : 4
- 10-bit A/D converter : 8 channels
- Interrupts : 1
Nonmaskable : Internal 16/external 2
Maskable
- Stand-by function : Software clock stop mode
STOP mode : Software CPU stop mode
HALT mode : Hardware CPU stop mode
HOLD mode

• Package

- 64-pin plastic shrink DIP (SDIP64-P-750-1.78) : (MSM66201-xxxSS) (MSM66P201-xxxSS)
(MSM66207-xxxSS) (MSM66P207-xxxSS)
- 64-pin plastic QFP (QFP64-P-1414-0.80-BK) : (MSM66201-xxxGSBK)(MSM66207xxxGS-
BK)
- 68-pin plastic QFJ (PLCC) (QFJ68-P-S950-1.27) : (MSM66201-xxxJS) (MSM66P201-xxxJS)
(MSM66207-xxxJS) (MSM66P207-xxxJS)
- 64-pin ceramic piggyback (ADIP64-C-750-1.78) : (MSM66G207VS)
(xxx indicates the code number.)

* The piggyback type is used only for engineering samples.

BLOCK DIAGRAM

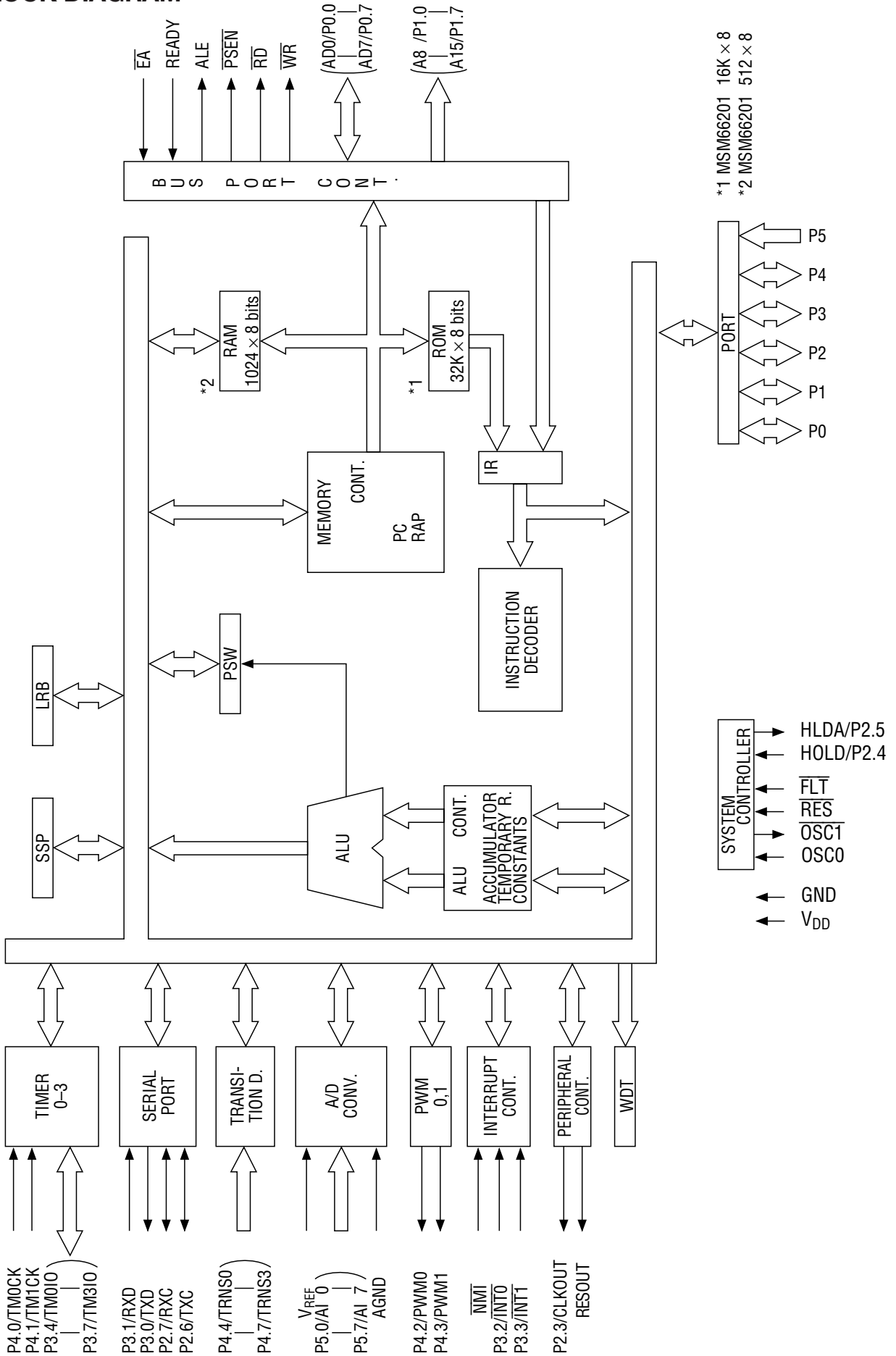

PIN CONFIGURATION (TOP VIEW)

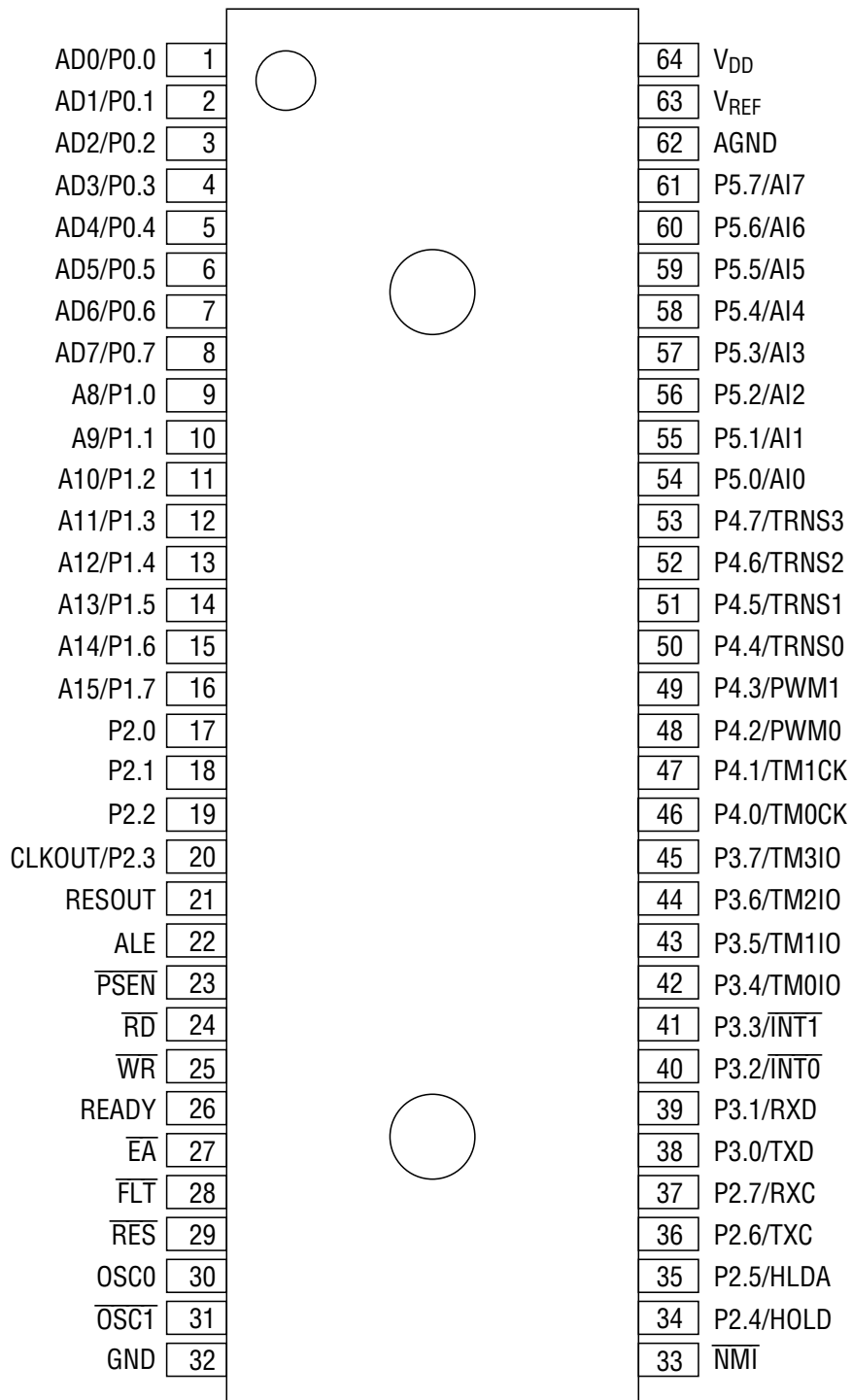

64-Pin Plastic Shrink DIP

PIN CONFIGURATION (TOP VIEW) (Continued)

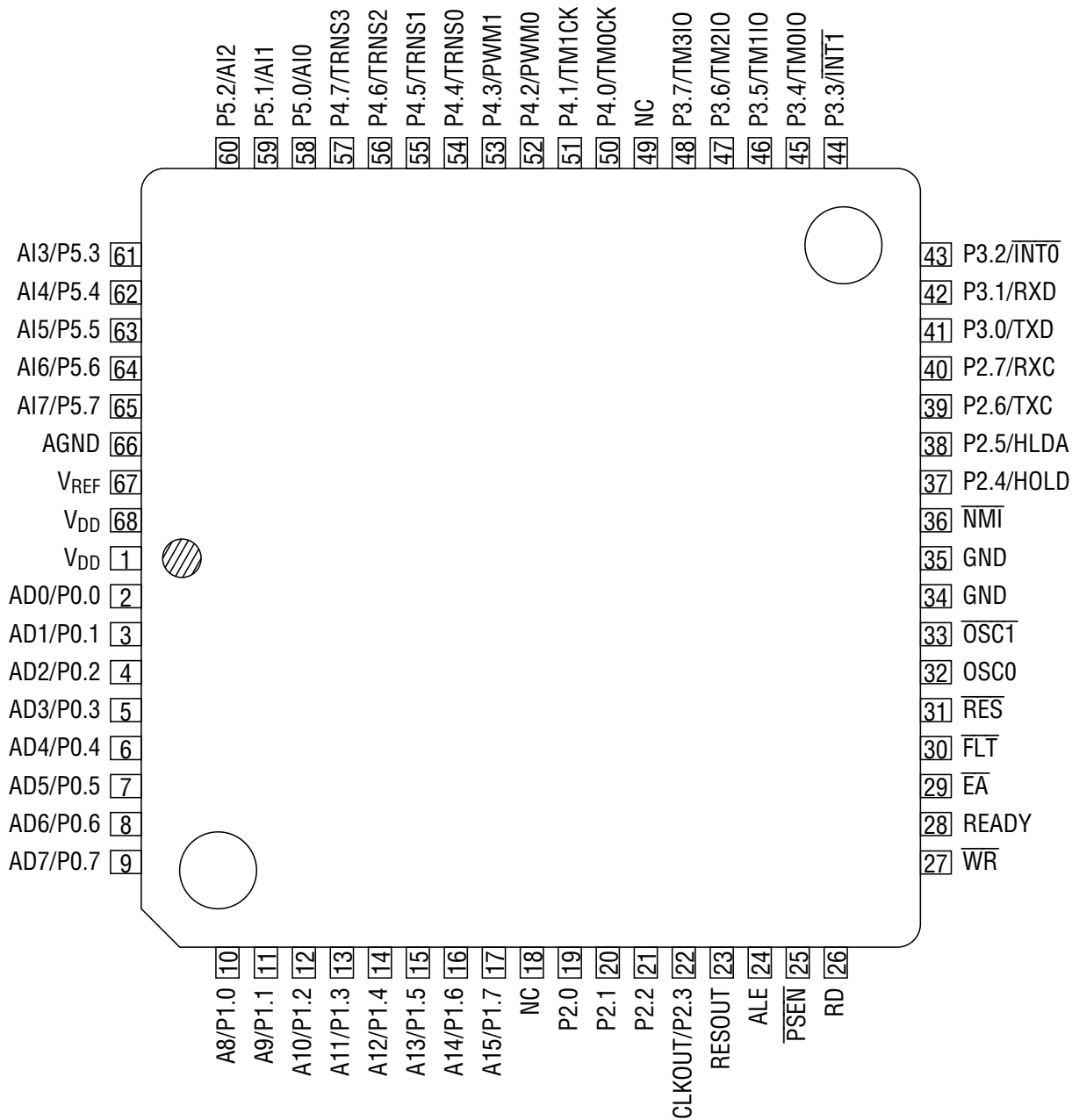

NC : No-connection pin

68-Pin Plastic QFJ (PLCC)

PIN DESCRIPTION

| Symbol | Type | Description |
|--|------|---|
| P0.0–P0.7/ AD0–AD7 | I/O | P0: 8-bit input-output port. Each bit can be assigned to input or output. AD: Outputs the lower 8 bits of program counter during external program memory fetch, and receives the addressed instruction under the control of PSEN. This pin also outputs the address and outputs or inputs data during an external data memory access instruction, under the control of ALE, RD, and WR. |
| P1.0–P1.7/ A8–A15 | I/O | P1: 8-bit input-output port. Each bit can be assigned to input or output. A: Outputs the upper 8 bits of program counter (PC _{8–15}) during external program memory fetch. This pin also outputs the upper 8 bits of address during external data memory access instructions. |
| P2.0–P2.2 P2.3/CLKOUT P2.4/HOLD P2.5/HLDA P2.6/TxC P2.7/RxC | I/O | P2: 8-bit input-output port. Each bit can be assigned to input or output. CLKOUT: Output pin for supplying a clock to peripheral circuits. HOLD: Input pin to request the CPU to enter the hardware power-down state. HLDA: HOLD ACKNOWLEDGE: the HLDA signal appears in response to the HOLD signal and indicates that the CPU has entered the power-down state. TxC: Transmitter clock input/output pin. RxC: Receiver clock input/output pin. |
| P3.0/TxD P3.1/RxD P3.2/INT0 P3.3/INT1 P3.4/TM0IO P3.5/TM1IO P3.6/TM2IO P3.7/TM3IO | I/O | P3: 8-bit input-output port. Each bit can be assigned to input or output. TxD: Transmitter data output pin. RxD: Receiver data input pin. INT: Interrupt request input pin. Falling edge trigger or level trigger is selectable. TM0IO–TM3IO: One of the following signals is output or input. <ul style="list-style-type: none"> • Clock at twice the frequency range of the 16-bit timer overflow • Load trigger signal to the capture register input • Setting value output Whether the signal is input or output depends on the mode. |
| P4.0/TM0CK P4.1/TM1CK P4.2/PWM0 P4.3/PWM1 P4.4 – P4.7/ TRANS0 – TRANS3 | I/O | P4: 8-bit input-output port. Each bit can be assigned to input or output. TM0CK, TM1CK: Clock input pins of timer 0, timer 1. TRANS: Transition detector. The input pins which sense the falling edge and set the flag. PWM: 16-bit pulse-width modulator output pin. |
| P5.0 – P5.7/ AI0 –AI7 | I | P5: 8-bit input port. AI: Analog signal input pin for A/D converter. |

PIN DESCRIPTION (Continued)

| Symbol | Type | Description |
|--------------------------|------|--|
| RESOUT | 0 | Outputs "H" level in the case of internal reset. Reset to "L" level by program. |
| ALE | 0 | Address Latch Enable: The timing pulse to latch the lower 8 bits of the address output from port 0 when the CPU accesses the external memory. |
| $\overline{\text{PSEN}}$ | 0 | Program Strobe Enable: The strobe pulse to fetch to external program memory. |
| $\overline{\text{RD}}$ | 0 | Output strobe activated during a bus read cycle. Used to enable data onto the bus from the external data memory. |
| $\overline{\text{WR}}$ | 0 | Output strobe during a bus write cycle. Used as write strobe to external data memory. |
| READY | I | Used when the CPU accesses low-speed peripherals. |
| $\overline{\text{EA}}$ | I | Normally set to "H" level. If set to "L" level, the CPU fetches the code from external program memory. |
| $\overline{\text{FLT}}$ | I | If $\overline{\text{FLT}}$ is "H" level, ALE, $\overline{\text{WR}}$, $\overline{\text{RD}}$, $\overline{\text{PSEN}}$ are set to "H" level when reset. If $\overline{\text{FLT}}$ is set to "L", ALE, $\overline{\text{WR}}$, $\overline{\text{RD}}$, $\overline{\text{PSEN}}$ are set to floating level when reset. |
| $\overline{\text{RES}}$ | I | RESET input pin. |
| OSCO | I | Basic clock oscillation pin. |
| $\overline{\text{OSCT}}$ | 0 | Basic clock oscillation pin. |
| $\overline{\text{NMI}}$ | I | Non-maskable interrupt input pin (falling edge). |
| V_{REF} | — | Reference voltage input pin for A/D converter. |
| AGND | — | Ground for A/D converter. |
| V_{DD} | — | System power supply. |
| GND | — | Ground. |

REGISTERS

Accumulator

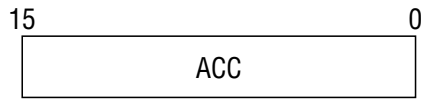

Control Register (CR)

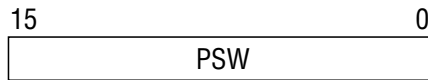

- Bit 15 : Carry flag (CY)
- Bit 14 : Zero flag (ZF)
- Bit 13 : Half carry flag (HC)
- Bit 12 : Data descriptor (DD)
- Bit 8 : Master interrupt priority flag (MIP)
- Bit 9,5,4: User flag (MIP)
- Bit 2-0 : System control base 2-0 (SCB2-0)

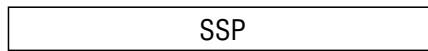
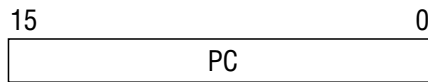

Pointing Register (PR)

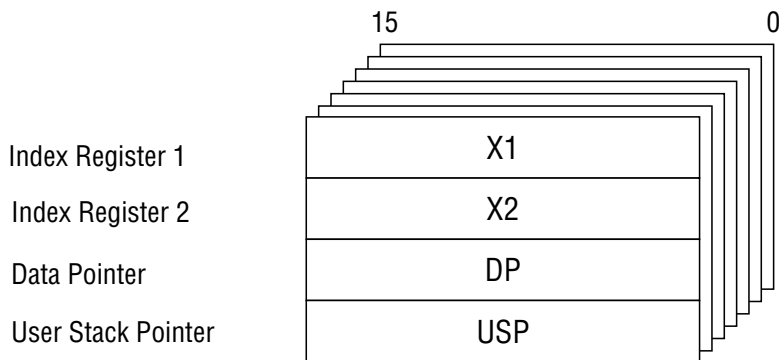

Local Register

| | | | | |
|-----|----|---|----|---|
| | 7 | 0 | 7 | 0 |
| ER0 | R1 | | R0 | |
| ER1 | R3 | | R2 | |
| ER2 | R5 | | R4 | |
| ER3 | R7 | | R6 | |

SFR

| Address (HEX) | Name | Symbol | R/W | 8/16-bit Operation | Reset | | |
|---------------|--|----------------|-----|--------------------|-----------|---|-----------------------|
| 0000 | System stack pointer | SSP (ASSP) | R/W | 8/16 | FFH | | |
| 0001 | | | | | FFH | | |
| 0002 | Local register base | LRB (ALRB) | | | undefined | | |
| 0003 | | | | | undefined | | |
| 0004☆ | Program status word | PSWL (APSW) | | | C8H | | |
| 0005☆ | | PSWH | | | 0CH | | |
| 0006 | Accumulator | ACC | | | 00H | | |
| 0007 | | | | | 00H | | |
| 0010☆ | Standby control register | SBYCON | | | | 8 | F8H |
| 0011 | Watchdog timer | WDT | | | W | | 00H/WDT is stopped |
| 0012☆ | Peripheral control register | PRPHF | R/W | | FDH | | |
| 0013 | Stop code acceptor | STPACP | W | | "0" | | |
| 0018 | Interrupt request register | IRQ | R/W | 8/16 | 00H | | |
| 0019 | | | | | 00H | | |
| 001A | Interrupt enable register | IE | | | 00H | | |
| 001B | | | | | 00H | | |
| 001C☆ | External interrupt control register | EXICON | | | | | FCH |
| 0020 | Port 0 data register | P0 | | | | | undefined |
| 0021 | Port 0 mode register | P0IO | | | | | 00H |
| 0022 | Port 1 data register | P1 | | | | | undefined |
| 0023 | Port 1 mode register | P1IO | | | | | 00H |
| 0024 | Port 2 data register | P2 | | | | | undefined |
| 0025 | Port 2 mode register | P2IO | | | 00H | | |
| 0026☆ | Port 2 secondary function control register | P2SF | | | 07H | | |
| 0028 | Port 3 data register | P3 | | | undefined | | |
| 0029 | Port 3 mode register | P3IO | | | 00H | | |
| 002A | Port 3 secondary function control register | P3SF | | | 00H | | |
| 002C | Port 4 data register | P4 | | | undefined | | |
| 002D | Port 4 mode register | P4IO | | | 00H | | |
| 002E | Port 4 secondary function control register | P4SF | | | 00H | | |
| 002F | Port 5 | P5 | R | | — | | |
| 0030 | Timer 0 counter | TM0 | R/W | 16 | 00H | | |
| 0031 | | | | | 00H | | |
| 0032 | Timer 0 register | TMR0 | | | 00H | | |
| 0033 | | | | | 00H | | |
| 0034 | Timer 1 counter | TM1 | | | 00H | | |
| 0035 | | | | | 00H | | |
| 0036 | Timer 1 register | TMR1 | | | 00H | | |
| 0037 | | | | | 00H | | |

Note: A ☆ mark in the address column indicates that there is a bit that does not exist in the register.

SFR (Continued)

| Address (HEX) | Name | Abbreviated Name | R/W | 8/16-bit Operation | Reset | |
|---------------|---|------------------|-----|--------------------|-----------|---|
| 0038 | Timer 2 counter | TM2 | R/W | 16 | 00H | |
| 0039 | | | | | 00H | |
| 003A | Timer 2 register | TMR2 | | | 00H | |
| 003B | | | | | 00H | |
| 003C | Timer 3 counter | TM3 | | | 00H | |
| 003D | | | | | 00H | |
| 003E | Timer 3 register | TMR3 | | | 00H | |
| 003F | | | | | 00H | |
| 0040 | Timer 0 control register | TCON0 | | | R/W | 8 |
| 0041 | Timer 1 control register | TCON1 | | 00H | | |
| 0042 | Timer 2 control register | TCON2 | | 00H | | |
| 0043 | Timer 3 control register | TCON3 | | 00H | | |
| 0046☆ | Transition detector register | TRNSIT | | undefined | | |
| 0048 | Serial port transmission baud rate generator counter | STTM | | 00H | | |
| 0049 | Serial port transmission baud rate generator register | STTMR | | 00H | | |
| 004A☆ | Serial port transmission baud rate generator control register | STTMC | | 0CH | | |
| 004C | Serial port receiving baud rate generator counter | SRTM | 00H | | | |
| 004D | Serial port receiving baud rate generator register | SRTMR | 00H | | | |
| 004E☆ | Serial port receiving baud rate generator control register | SRTMC | 0EH | | | |
| 0050☆ | Serial port transmission mode control register | STCON | 80H | | | |
| 0051 | Serial port transmission data buffer register | STBUF | W | undefined | | |
| 0054 | Serial port receiving mode control register | SRCON | R/W | 00H | | |
| 0055 | Serial port receiving data buffer register | SRBUF | R | undefined | | |
| 0056☆ | Serial port receiving error register | SRSTAT | R/W | F0H | | |
| 0058☆ | A/D scan mode register | ADSCAN | | 80H | | |
| 0059☆ | A/D select mode register | ADSEL | | A0H | | |
| 0060☆ | A/D conversion result register 0 | ADCRO | R | 8/16 | undefined | |
| 0061 | | | | | | |

Note: A ☆ mark in the address column indicates that there is a bit that does not exist in the register.

SFR (Continued)

| Address (HEX) | Name | Abbreviated Name | R/W | 8/16-bit operation | Reset |
|---------------|----------------------------------|------------------|-----|--------------------|-----------|
| 0062☆ 0063 | A/D conversion result register 1 | ADCR1 | R | 8/16 | undefined |
| 0064☆ 0065 | A/D conversion result register 2 | ADCR2 | | | |
| 0066☆ 0067 | A/D conversion result register 3 | ADCR3 | | | |
| 0068☆ 0069 | A/D conversion result register 4 | ADCR4 | | | |
| 006A☆ 006B | A/D conversion result register 5 | ADCR5 | | | |
| 006C☆ 006D | A/D conversion result register 6 | ADCR6 | | | |
| 006E☆ 006F | A/D conversion result register 7 | ADCR7 | | | |
| 0070 0071 | PWM 0 counter | PWMC0 | R/W | 8 | 00H |
| 0072 0073 | PWM 0 register | PWMR0 | | | 00H |
| 0074 0075 | PWM 1 counter | PWMC1 | | | 00H |
| 0076 0077 | PWM 1 register | PWMR1 | | | 00H |
| 0078 | PWM 0 control register | PWCON0 | | | 00H |
| 007A | PWM 1 control register | PWCON1 | | | 00H |

Note: A ☆ mark in the address column indicates that there is a bit that does not exist in the register.

ADDRESSING MODES

The MSM66201/66207 provides independent 64K-byte data and 64K-byte program space with various types of addressing modes. These modes are shown below, for both RAM (for data space) and ROM (for program space).

1. RAM Addressing Modes (for data space)

1.1 Register Direct Addressing

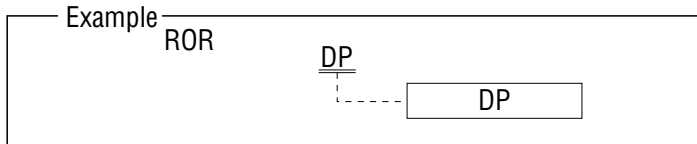

1.2 Displacement Addressing

a) Zero Page

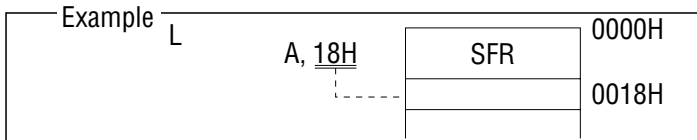

b) Direct Page

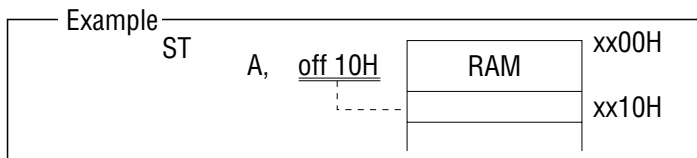

1.3 Pointing Register (PR) Indirect Addressing

a) Data Point (DP) Indirect

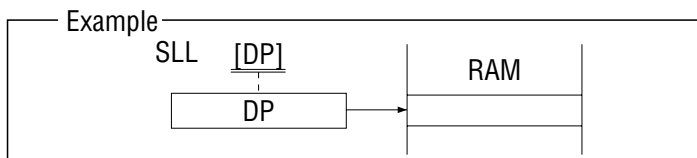

b) User Stack Pointer (USP) Indirect

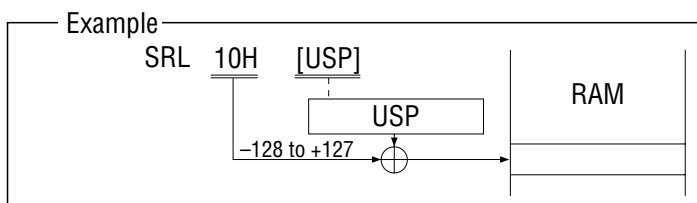

c) Index Register (X1, X2) Indirect

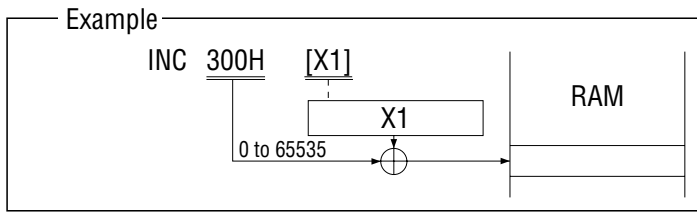

1.4 Immediate Addressing

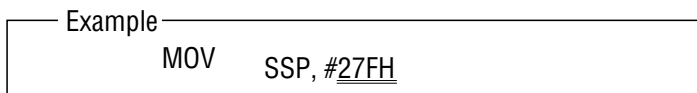

2. ROM Addressing Modes (for program space)

2.1 Direct Addressing

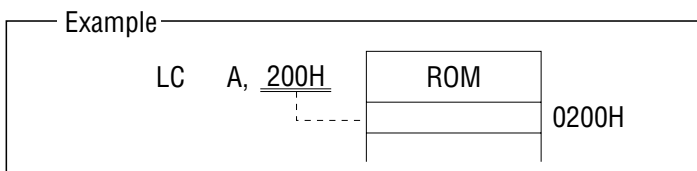

2.2 Simple Indirect Addressing

a) Local Register Indirect

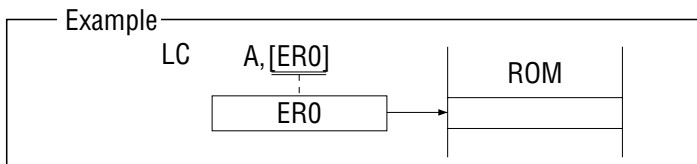

b) Pointing Register Indirect

1) Data Pointer (DP) Indirect

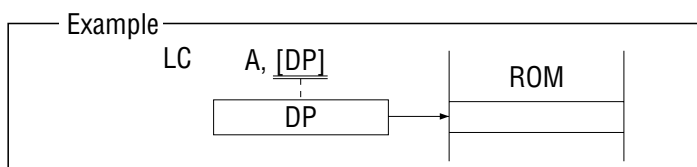

2) User Stack Pointer (USP) Indirect

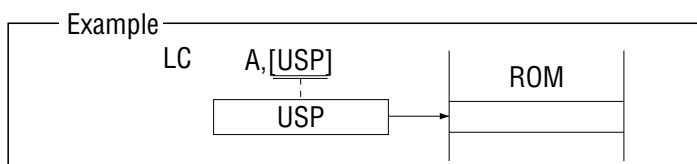

3) Index Register (X1, X2) Indirect

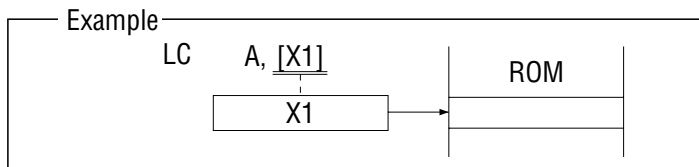

c) System Stack Pointer (SSP) Indirect

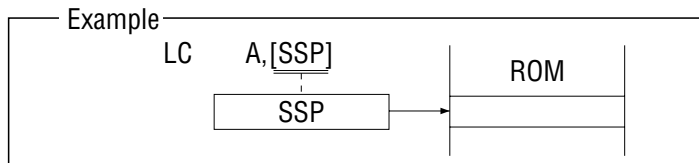

d) Local Register Base (LRB) Indirect

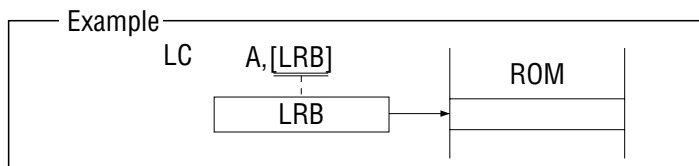

e) RAM Indirect

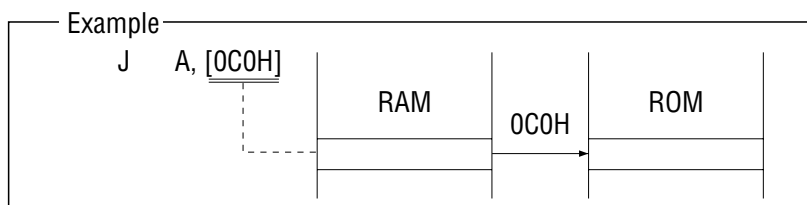

2.3 Double Indirect Addressing

a) Data Pointer (DP) Double Indirect

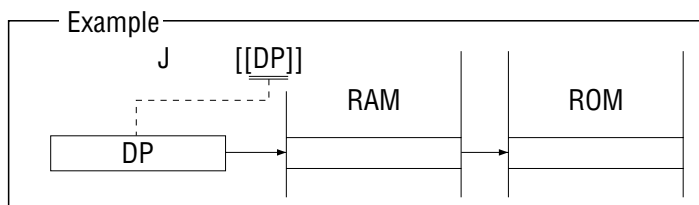

b) User Stack Pointer (USP) Double Indirect

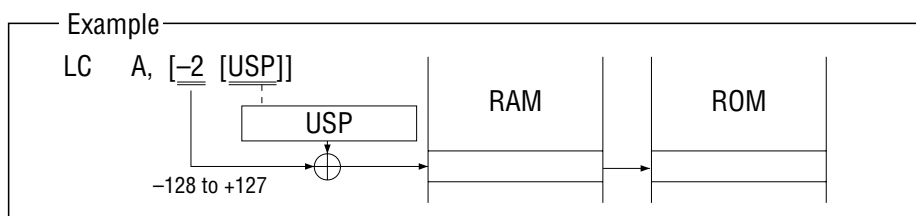

c) Index Register (X1, X2) Double Indirect

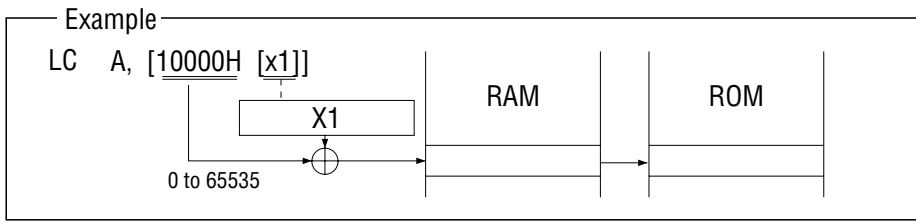

2.4 Indirect Addressing with 16-bit Offset

a) Pointing Register Indirect

1) Data Pointer (DP) Indirect

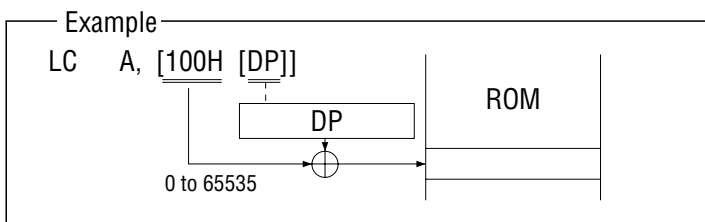

2) User Stack Pointer (USP) Indirect

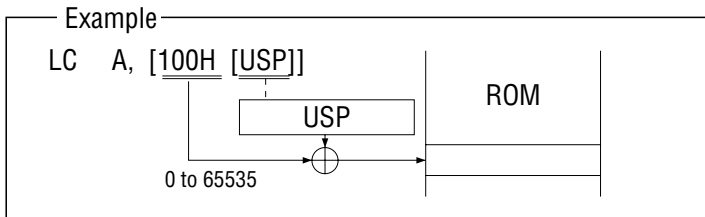

3) Index Register (X1, X2) Indirect

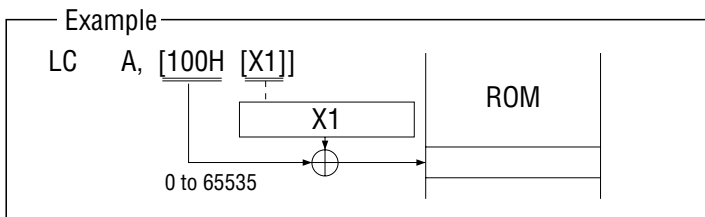

b) RAM Indirect

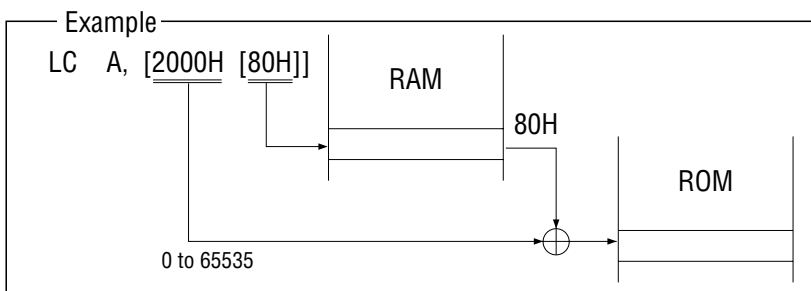

MEMORY MAPS

Program Memory Space

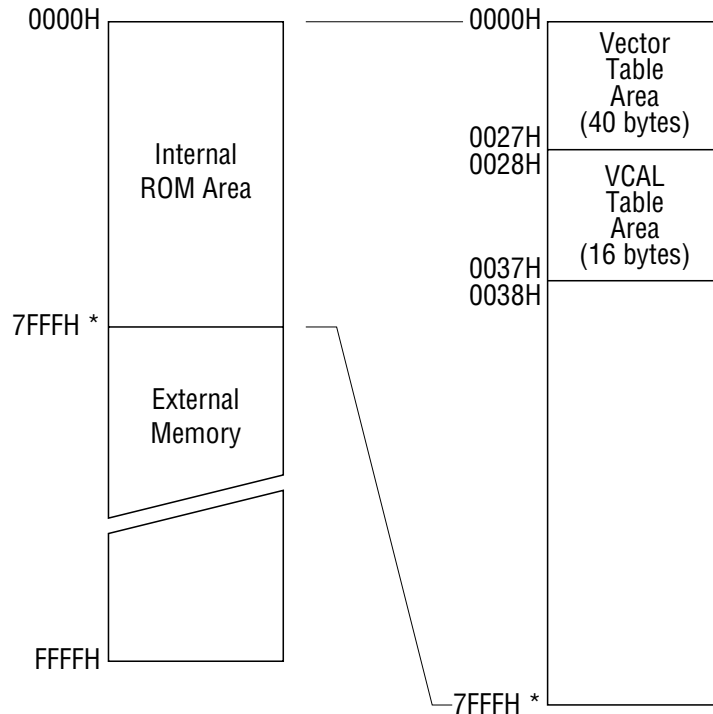

* MSM66201 : 3FFFH

Data Memory Space

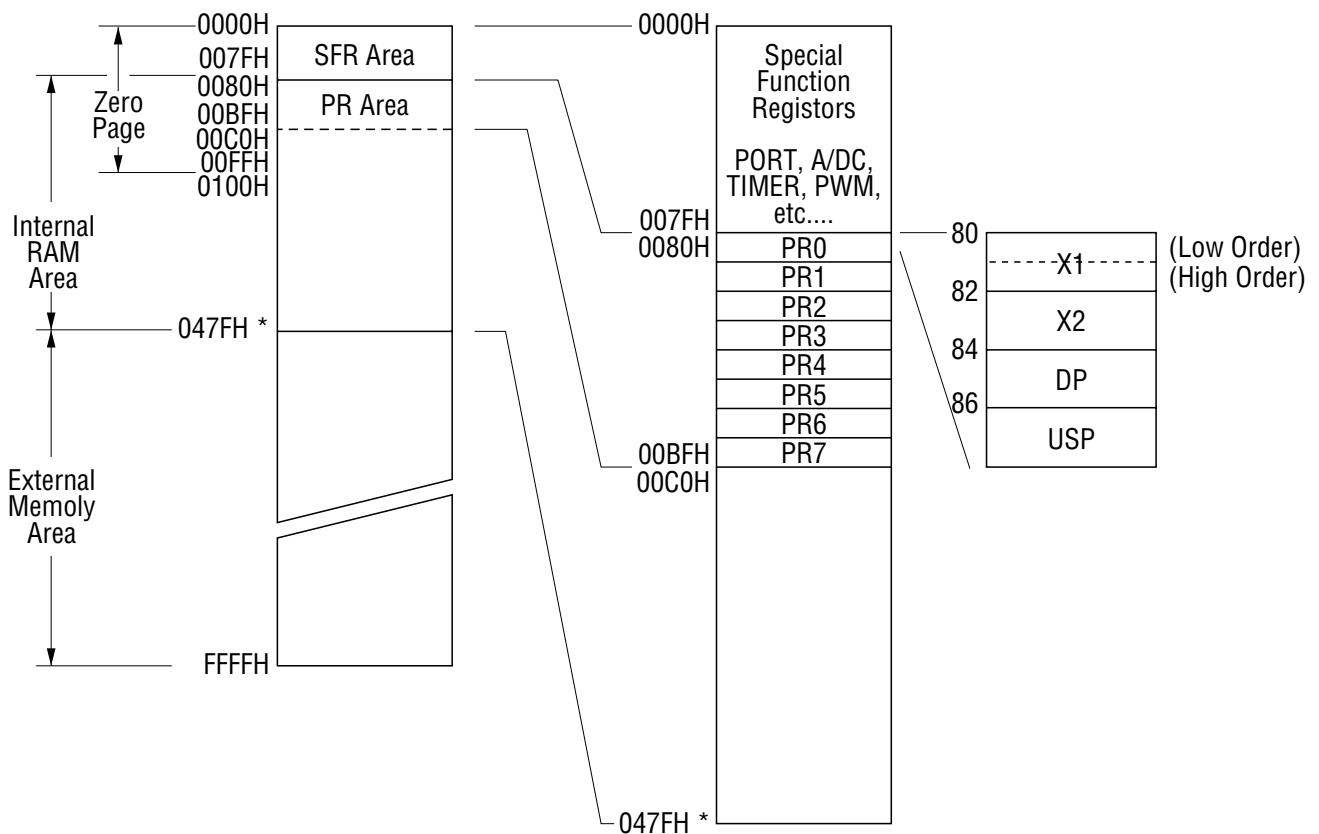

* MSM66201 : 027FH

ABSOLUTE MAXIMUM RATINGS

(Ta=25°C)

| Parameter | Symbol | Condition | | Rating | Unit |
|----------------------|------------------|------------------------|-------------------|------------------------------|------|
| Supply Voltage | V _{DD} | GND=AGND=0V | | -0.3 to 7.0 | V |
| Input Voltage | V _I | | | -0.3 to V _{DD} +0.3 | |
| Output Voltage | V _O | | | -0.3 to V _{DD} +0.3 | |
| Analog Ref. Voltage | V _{REF} | | | -0.3 to V _{DD} +0.3 | |
| Analog Input Voltage | V _{AI} | | | -0.3 to V _{REF} | |
| Power Dissipation | P _D | Ta=85°C per Package | 64-pin shrink DIP | 930 | mW |
| | | | 64-pin QFP | 565 | |
| | | | 68-pin QFJ | 1120 | |
| Storage Temperature | T _{STG} | — | | -55 to +150 | °C |

RECOMMENDED OPERATING CONDITIONS

| Parameter | Symbol | Condition | Range | Unit | |
|---------------------|------------------|---------------------------|----------------|------|---|
| Supply Voltage | V _{DD} | f _{OSC} ≤ 10MHz | 4.5 to 5.5 | V | |
| Memory Hold Voltage | V _{DDH} | f _{OSC} = 0Hz | 2.0 to 5.5 | | |
| Operating Frequency | f _{OSC} | V _{DD} = 5V ±10% | 0 to 10 | MHz | |
| Ambient Temperature | Ta | — | -40 to +85 | °C | |
| Fan Out | N | MOS load | 20 | — | |
| | | TTL load | P0 | | 2 |
| | | | P1, P2, P3, P4 | | 1 |

ELECTRICAL CHARACTERISTICS

DC Characteristics

($V_{DD} = 5V \pm 10\%$, $T_a = -40$ to $+85^\circ C$)

| Parameter | Symbol | Condition | Min. | Typ. | Max. | Unit |
|---------------------------------------|-----------------|----------------------------------|------|------|--------------|---------|
| "H" Input Voltage 1, 3, 6 | V_{IH} | — | 2.4 | — | $V_{DD}+0.3$ | V |
| "H" Input Voltage 5, 7 | | | 4.0 | — | $V_{DD}+0.3$ | |
| "H" Input Voltage 8 | | | 4.2 | — | $V_{DD}+0.3$ | |
| "H" Input Voltage 2 | | | 3.6 | — | $V_{DD}+0.3$ | |
| "L" Input Voltage 1, 2, 3, 6 | V_{IL} | — | -0.3 | — | 0.8 | V |
| "L" Input Voltage 5, 7 | | | -0.3 | — | 0.8 | |
| "L" Input Voltage 8 | | | -0.3 | — | 0.4 | |
| "H" Output Voltage 1, 4 | V_{OH} | $I_O = -400\mu A$ | 4.2 | — | — | |
| "H" Output Voltage 2 | | $I_O = -200\mu A$ | 4.2 | — | — | |
| "L" Output Voltage 1, 4 | V_{OL} | $I_O = 3.2mA$ | — | — | 0.4 | |
| "L" Output Voltage 2 | | $I_O = 1.6mA$ | — | — | 0.4 | |
| Input Leakage Current 3, 6, 7 | I_{IH}/I_{IL} | $V_I = V_{DD}/0V$ | — | — | 1/-1 | μA |
| Input Current 5 | | | — | — | 1/-20 | |
| Input Current 8 | | | — | — | 10/-10 | |
| "H" Output Current 1 | I_{OH} | $V_O = 2.4V$ | -2 | — | — | mA |
| "H" Output Current 2 | | | -1 | — | — | |
| "L" Output Current 1 | I_{OL} | | 10 | — | — | |
| "L" Output Current 2 | | | 5 | — | — | |
| Output Leakage Current 1, 2, 4 | I_{LO} | $V_O = V_{DD}/0V$ | — | — | ± 2 | μA |
| Input Capacitance | C_I | $f = 1MHz$ $T_a = 25^\circ C$ | — | 5 | — | pF |
| Output Capacitance | C_O | | — | 7 | — | |
| Analog Reference Power Supply Current | I_{REF} | A/D in operation | — | 0.3 | 2 | mA |
| | | A/D stopped | — | 0.5 | 10 | μA |
| Current Consumption (during STOP) * | I_{DDS} | $V_{DD} = 2V$ | — | 0.2 | 10 | μA |
| | | — | — | 1 | 100 | |
| Current Consumption (during HALT) | I_{DDH} | $f_{OSC} = 10MHz$ No Load | — | 6 | 10 | mA |
| | | | **— | 8 | 15 | |
| Current Consumption | I_{DD} | | — | 20 | 35 | |
| | | | **— | 30 | 40 | |

- Note: 1 Applied to P0
 2 Applied to P1, P2, P3 and P4
 3 Applied to P5
 4 Applied to \overline{ALE} , \overline{PSEN} , \overline{RD} , \overline{WR} and RESOUT
 5 Applied to \overline{RES} and \overline{NMI}
 6 Applied to READY and \overline{EA}
 7 Applied to \overline{FLT}
 8 Applied to OSC₀
 * V_{DD} or GND for ports serving as the input pin. No load for any other.
 ** Applied to MSM66P201/66P207

AC Characteristics

• **External program memory control**

($V_{DD}=5V\pm 10\%$, $T_a=-40$ to $+85^\circ C$)

| Parameter | Symbol | Condition | Min. | Max. | Unit |
|-------------------------|--------------|--------------|------------------|------------------|------|
| Clock (OSC) Pulse | $t_{\phi W}$ | — | 50 | — | ns |
| ALE Pulse Width | t_{AW} | $C_L = 50pF$ | $3t_{\phi W}-20$ | — | |
| PSEN Pulse Width | t_{PW} | | $4t_{\phi W}-20$ | — | |
| PSEN Pulse Delay Time | t_{PAD} | | $t_{\phi W}-20$ | $t_{\phi W}+20$ | |
| Low Address Setup time | t_{AAS} | | $2t_{\phi W}-35$ | $2t_{\phi W}+20$ | |
| Low Address Hold Time | t_{AAH} | | $t_{\phi W}-20$ | $t_{\phi W}+40$ | |
| High Address Delay Time | t_{AAD} | | $t_{\phi W}-20$ | $t_{\phi W}+40$ | |
| High Address Hold Time | t_{APH} | | $t_{\phi W}-20$ | $t_{\phi W}+40$ | |
| Instruction Setup Time | t_{IS} | | 100 | — | |
| Instruction Hold Time | t_{IH} | | 0 | $t_{\phi W}-20$ | |

• **External data memory control**

($V_{DD}=5V\pm 10\%$, $T_a=-40$ to $+85^\circ C$)

| Parameter | Symbol | Condition | Min. | Max. | Unit |
|----------------------------------|--------------|--------------|------------------|------------------|------|
| Clock (OSC) Pulse | $t_{\phi W}$ | — | 50 | — | ns |
| ALE Pulse Width | t_{AW} | $C_L = 50pF$ | $3t_{\phi W}-20$ | — | |
| \overline{RD} Pulse Width | t_{RW} | | $4t_{\phi W}-20$ | — | |
| \overline{WR} Pulse Width | t_{WW} | | $4t_{\phi W}-20$ | — | |
| \overline{RD} Pulse Delay Time | t_{RAD} | | $t_{\phi W}-20$ | $t_{\phi W}+20$ | |
| \overline{WR} Pulse Delay Time | t_{WAD} | | $t_{\phi W}-20$ | $t_{\phi W}+20$ | |
| Low Address Setup Time | t_{AAS} | | $2t_{\phi W}-35$ | $2t_{\phi W}+20$ | |
| Low Address Hold Time | t_{AAH} | | $t_{\phi W}-20$ | $t_{\phi W}+40$ | |
| High Address Setup Time | t_{AAD} | | $t_{\phi W}-20$ | $t_{\phi W}+40$ | |
| High Address Hold Time | t_{ARH} | | $t_{\phi W}-20$ | $t_{\phi W}+40$ | |
| High Address Hold Time | t_{AWH} | | $t_{\phi W}-20$ | $t_{\phi W}+40$ | |
| Memory Data Setup Time | t_{MS} | | 100 | — | |
| Memory Data Hold Time | t_{MH} | | 0 | $t_{\phi W}-20$ | |
| Data Delay Time | t_{DD} | | $t_{\phi W}-20$ | $t_{\phi W}+40$ | |
| Data Hold Time | t_{DH} | | $t_{\phi W}-20$ | $t_{\phi W}+40$ | |

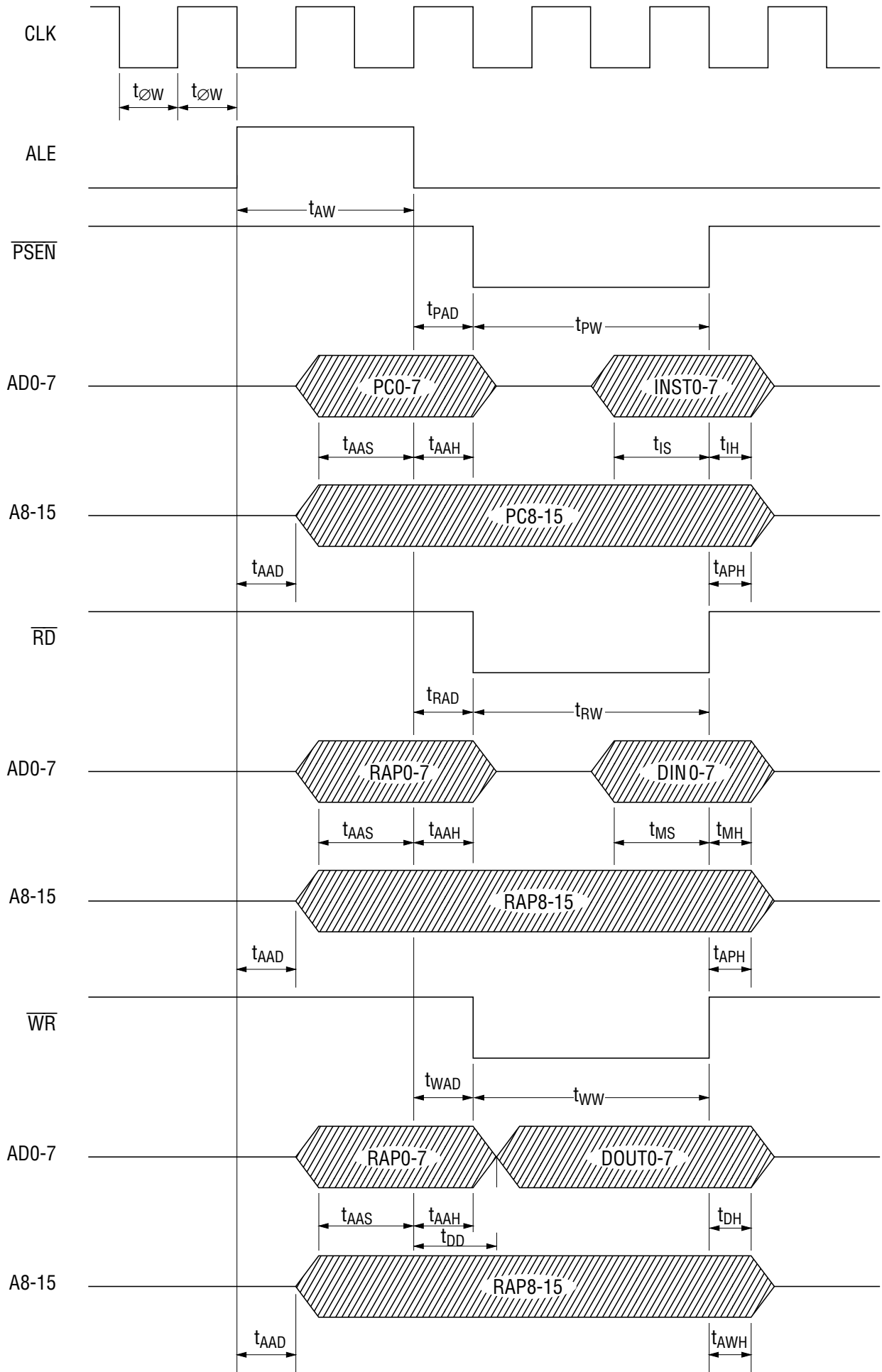

• Serial port control

Master mode

($V_{DD}=5V\pm 10\%$, $T_a=-40$ to $+85^\circ C$)

| Parameter | Symbol | Condition | Min. | Max. | Unit |
|--------------------------|--------------|------------|------------------|------|------|
| Clock (OSC) Pulse Width | $t_{\phi W}$ | — | 50 | — | ns |
| Serial Clock Pulse Width | t_{SCKW} | — | $8t_{\phi W}$ | — | |
| Output Data Setup Time | t_{STMXS} | $C_L=50pF$ | $8t_{\phi W}+40$ | — | |
| Output Data Hold Time | t_{STMXH} | | $6t_{\phi W}-20$ | — | |
| Input Data Setup Time | t_{SRMXS} | | $2t_{\phi W}+10$ | — | |
| Input Data Hold Time | t_{SRMXH} | | 50 | — | |

Slave mode

($V_{DD}=5V\pm 10\%$, $T_a=-40$ to $+85^\circ C$)

| Parameter | Symbol | Condition | Min. | Max. | Unit |
|--------------------------|--------------|------------|------------------|------|------|
| Clock (OSC) Pulse Width | $t_{\phi W}$ | — | 50 | — | ns |
| Serial Clock Pulse Width | t_{SCKW} | — | $8t_{\phi W}$ | — | |
| Output Data Setup Time | t_{STSXS} | $C_L=50pF$ | $6t_{\phi W}+40$ | — | |
| Output Data Hold Time | t_{STSXH} | | $6t_{\phi W}-20$ | — | |
| Input Data Setup Time | t_{SRSXS} | | 100 | — | |
| Input Data Hold Time | t_{SRSXH} | | 100 | — | |

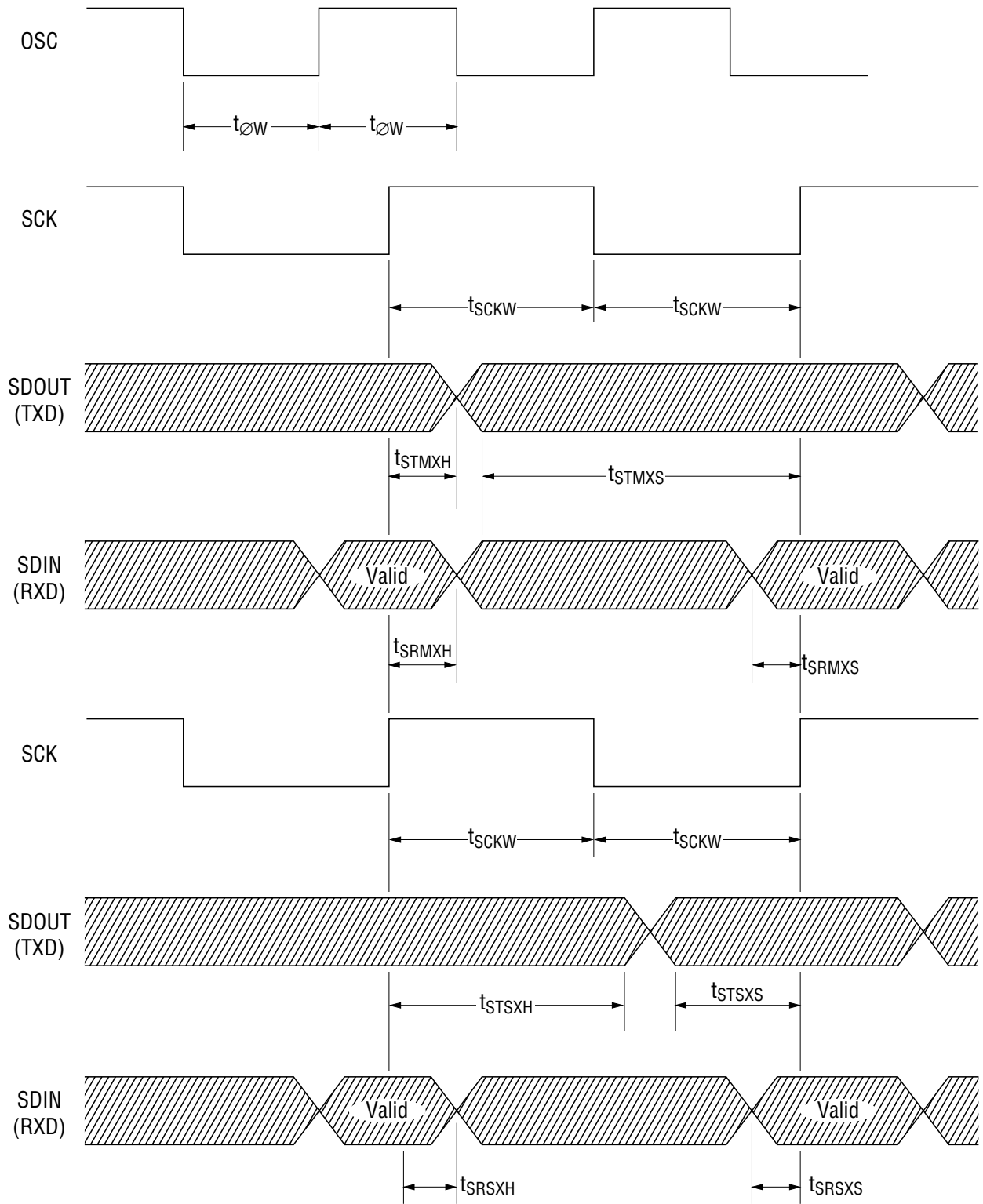

A/D Converter Characteristics

• **Operating range**

| Parameter | Symbol | Condition | Min. | Typ. | Max. | Unit |
|---|----------|-----------------------------------|----------|------|----------|--------------------|
| Power Supply Voltage | V_{DD} | $f_{OSC} \leq 10\text{MHz}$ | 4.5 | — | 5.5 | V |
| Analog Reference Voltage | V_R | $V_{AG} = \text{GND} = 0\text{V}$ | 4.5 | — | V_{DD} | |
| Analog Input Voltage | V_{AI} | | V_{AG} | — | V_R | |
| Analog Reference Power Voltage Resistance | R_R | | — | 16 | — | k Ω |
| Operating Temperature | T_{op} | $V_{DD} = 5\text{V} \pm 10\%$ | -40 | — | +85 | $^{\circ}\text{C}$ |

• **A/D Converter accuracy**

Normal operation mode

($V_{DD}=5\text{V} \pm 10\%$, $f_{OSC}=10\text{MHz}$, $T_a=-40$ to $+85^{\circ}\text{C}$)

| Parameter | Symbol | Condition | Min. | | Typ. | | Max. | | Unit |
|------------------------------|--------|--|------|------|-----------|-----------|--------------|--------------|------|
| | | | | * | | * | | * | |
| Resolution | n | See the recommended circuit. $V_R=V_{DD}$ $V_{AG}=\text{GND}=0\text{V}$ Analog input source impedance $\leq 5\text{k}\Omega$ One channel conversion time $t_C=64\mu\text{s}$ | — | — | — | — | 10 | 10 | Bit |
| Absolute Error | E_A | | — | — | — | — | +3.0 -3.5 | +2.0 -3.5 | LSB |
| Relative Error | E_R | | — | — | — | — | ± 1.5 | ± 1.0 | |
| Zero Point Error | E_Z | | 0 | 0 | — | — | +3.0 | +2.0 | |
| Full Scale Error | E_F | | -0.5 | -1.0 | — | — | -3.5 | -3.5 | |
| Differential Linearity Error | E_D | | — | — | — | — | +3.0 | +2.0 | |
| Crosstalk | E_C | | — | — | ± 0.5 | ± 0.5 | — | — | |

* $V_{DD}=5\text{V}$, $T_a=25^{\circ}\text{C}$

HALT/HOLD operation mode

($V_{DD}=5\text{V} \pm 10\%$, $f_{OSC}=10\text{MHz}$, $T_a=-40$ to $+85^{\circ}\text{C}$)

| Parameter | Symbol | Condition | Min. | | Typ. | | Max. | | Unit |
|------------------------------|--------|--|------|------|-----------|-----------|--------------|--------------|------|
| | | | | * | | * | | * | |
| Resolution | n | See the recommended circuit. $V_R=V_{DD}$ $V_{AG}=\text{GND}=0\text{V}$ Analog input source impedance $\leq 5\text{k}\Omega$ One channel conversion time $t_C=64\mu\text{s}$ | — | — | — | — | 10 | 10 | Bit |
| Absolute Error | E_A | | — | — | — | — | +2.0 -3.5 | +1.0 -2.0 | LSB |
| Relative Error | E_R | | — | — | — | — | ± 1.0 | ± 0.5 | |
| Zero Point Error | E_Z | | +0.5 | +0.5 | — | — | +2.0 | +1.0 | |
| Full Scale Error | E_F | | -1.0 | -1.5 | — | — | -3.5 | -2.0 | |
| Differential Linearity Error | E_D | | — | — | — | — | +2.0 | +1.0 | |
| Crosstalk | E_C | | — | — | ± 0.5 | ± 0.5 | — | — | |

* $V_{DD}=5\text{V}$, $T_a=25^{\circ}\text{C}$

• Recommended circuit

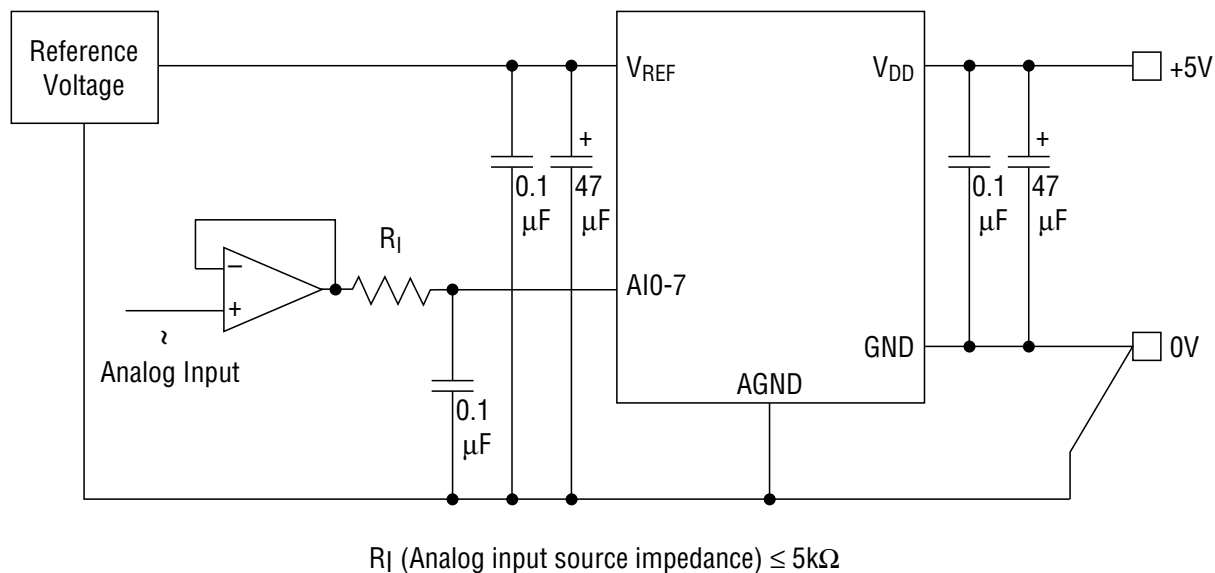

• A/D Converter conversion characteristics 1

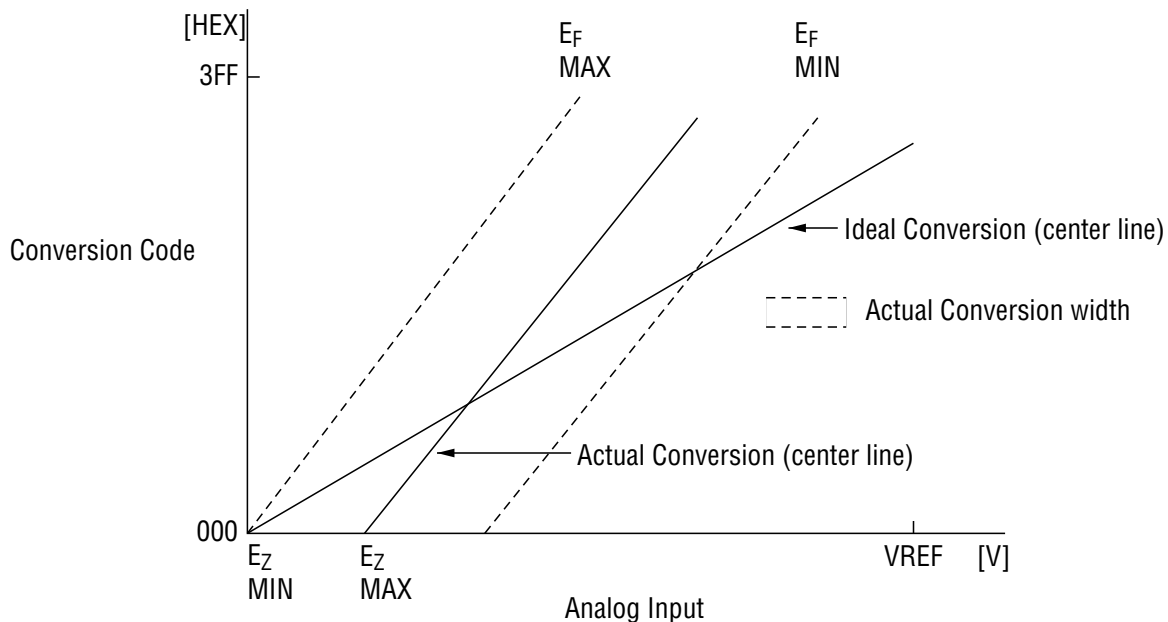

Conversion Characteristics Diagram 1

Absolute error (E_A)

The absolute error indicates a difference between actual conversion and ideal conversion, excluding a quantizing error. The absolute error of the A/D converter gets larger as it approaches the zero point or full scale. (Refer to Conversion Characteristics Diagram 1.)

Relative error (E_R)

The relative error indicates a deviation from a line which connects the center point of the zero point conversion width with that of the full scale conversion width, excluding a quantizing error.

The relative error of this A/D converter is almost due to a differential linearity error.

Zero point error (E_z) and full scale error (E_F)

The zero point error and full scale error indicate a difference between actual conversion and ideal conversion at the zero point and full scale, respectively. (Refer to Conversion Characteristics Diagram 1.)

A/D Converter Conversion Characteristics 2 (temperature characteristics)

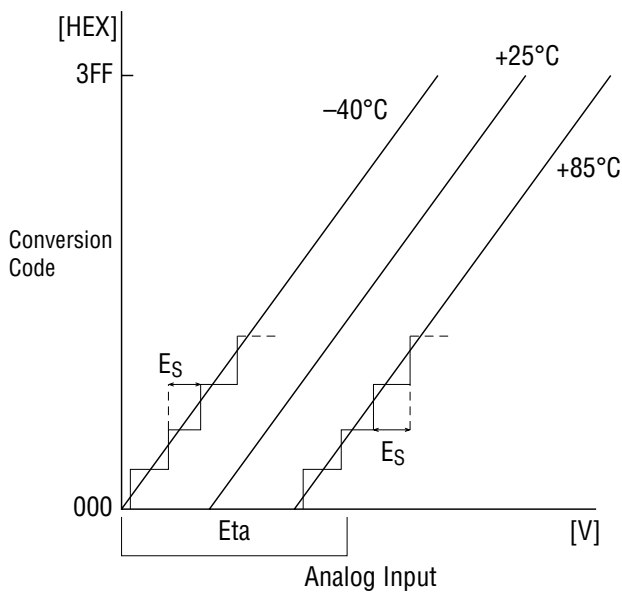

Conversion Characteristics Diagram 2-1

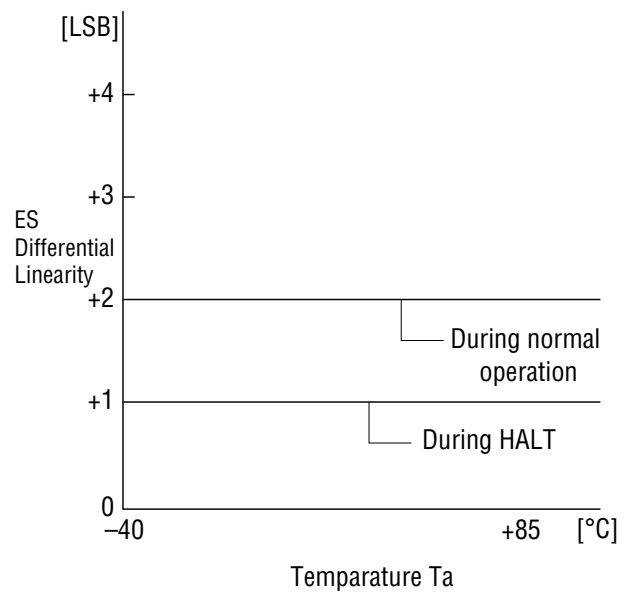

Conversion Characteristics Diagram 2-2

Differential linearity error (E_D)

The differential linearity error indicates a difference between the actual conversion width (actual step width) and ideal value (1LSB).

With this A/D converter, a voltage for actual conversion is shifted and the inclination of a voltage is changed, with changes of temperature (see Conversion Characteristics Diagram 2-1). Specifications described in the foregoing tables are established from Eta shown in Conversion Characteristics Diagram 2-1 ($E_D = \text{Eta} - 1\text{LSB}$). Conversion Characteristics Diagram 2-2 shows temperature characteristics of differential linearity of Es in Conversion Characteristics Diagram 2-1.

PACKAGE DIMENSIONS

(Unit : mm)

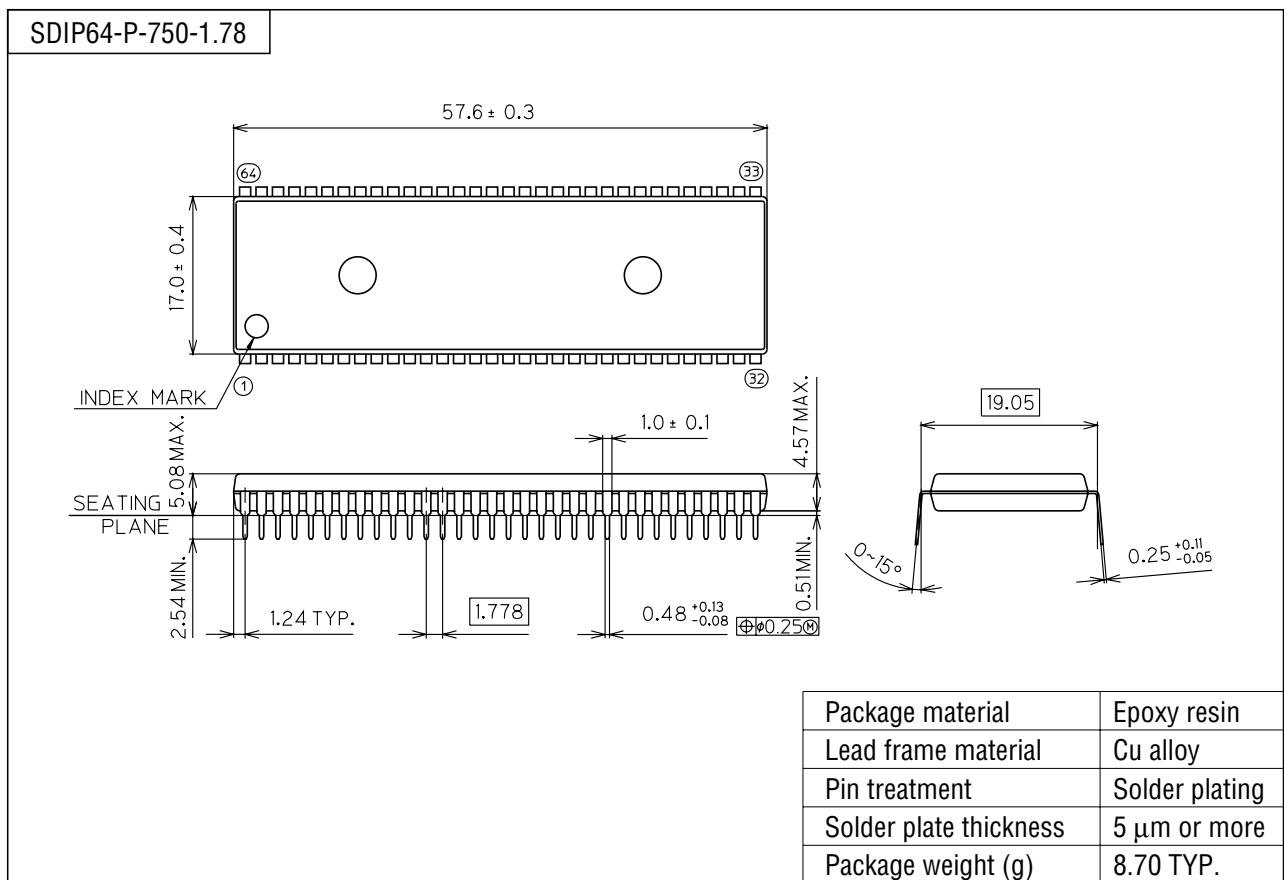

Notes for Mounting the Surface Mount Type Package

The SOP, QFP, TSOP, SOJ, QFJ (PLCC), SHP and BGA are surface mount type packages, which are very susceptible to heat in reflow mounting and humidity absorbed in storage. Therefore, before you perform reflow mounting, contact Oki's responsible sales person for the product name, package name, pin number, package code and desired mounting conditions (reflow method, temperature and times).

(Unit : mm)

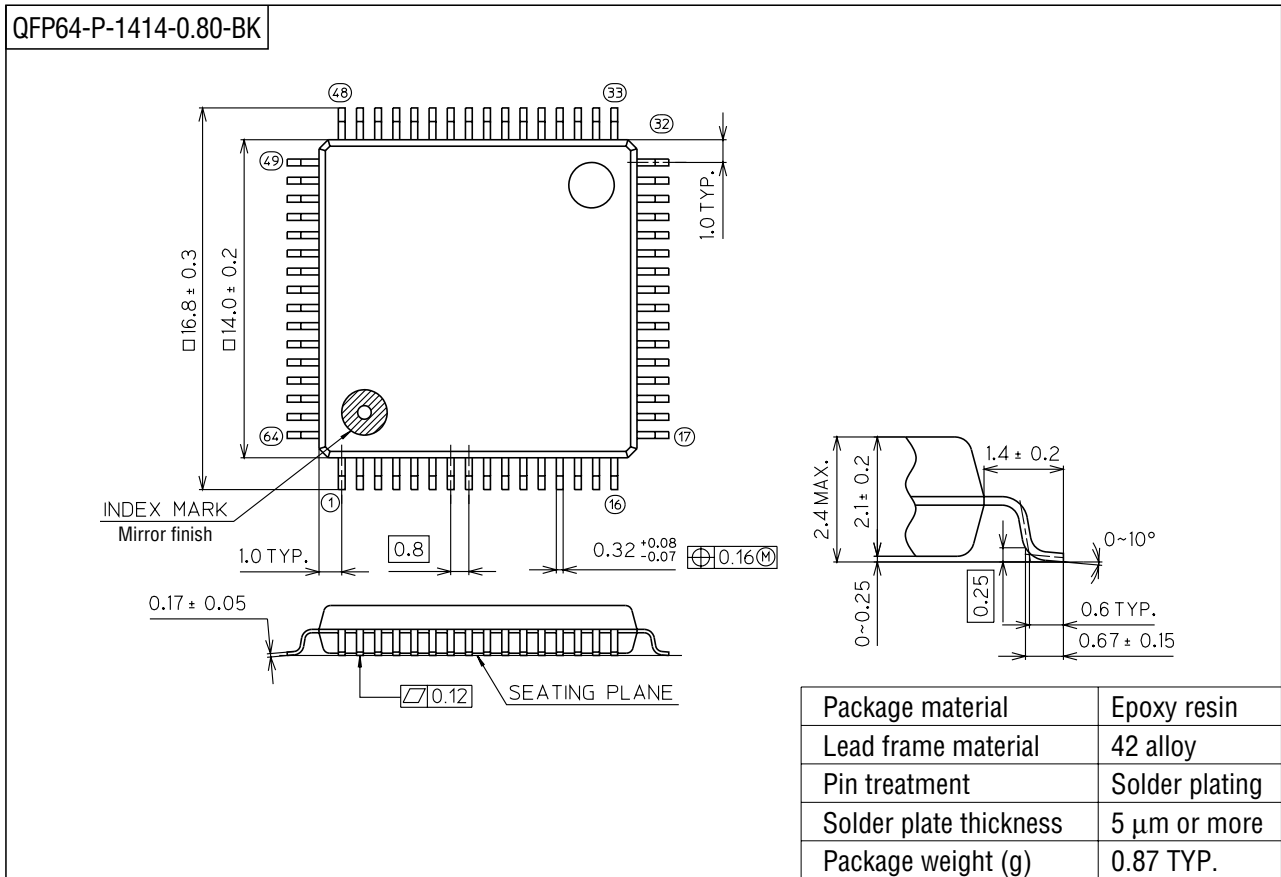

Notes for Mounting the Surface Mount Type Package

The SOP, QFP, TSOP, SOJ, QFJ (PLCC), SHP and BGA are surface mount type packages, which are very susceptible to heat in reflow mounting and humidity absorbed in storage. Therefore, before you perform reflow mounting, contact Oki's responsible sales person for the product name, package name, pin number, package code and desired mounting conditions (reflow method, temperature and times).

(Unit : mm)

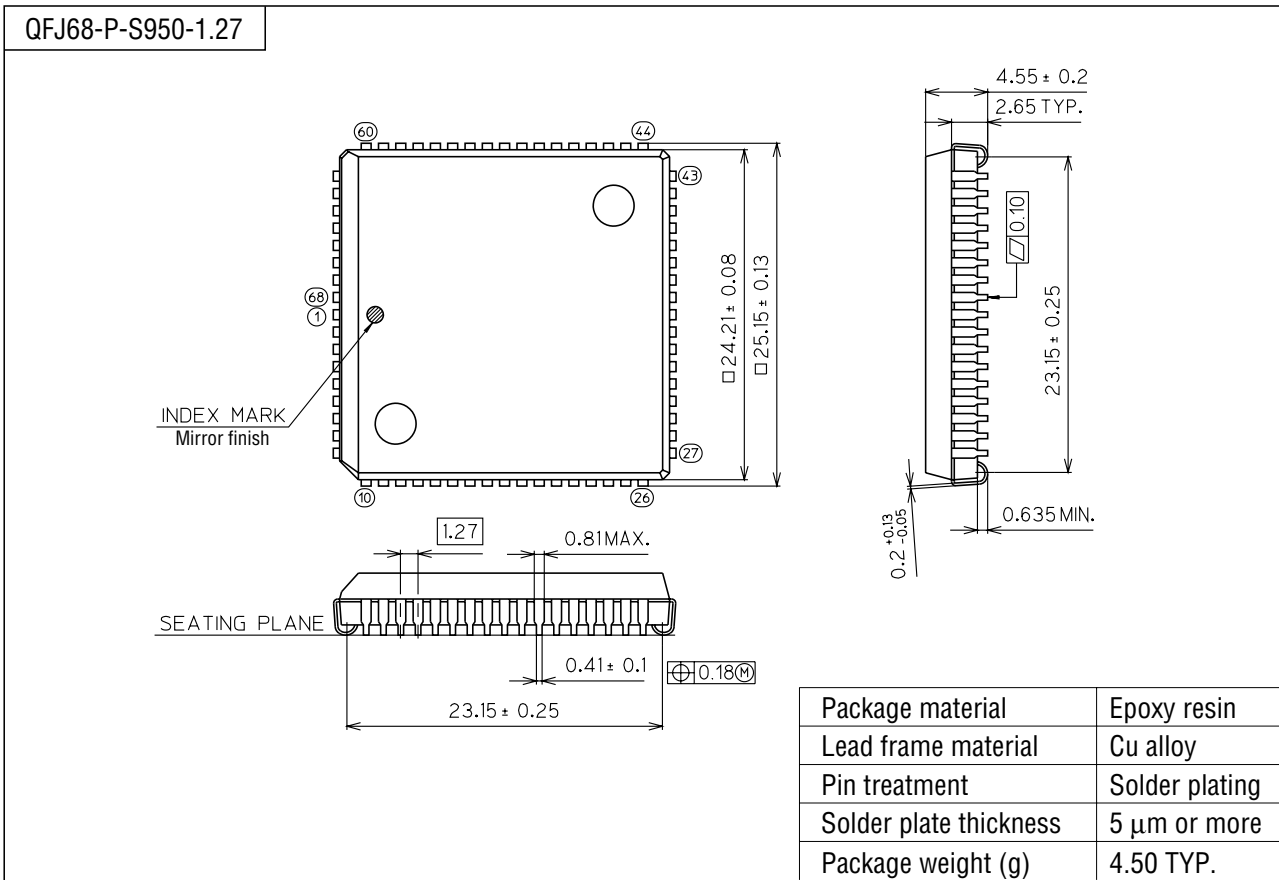

Notes for Mounting the Surface Mount Type Package

The SOP, QFP, TSOP, SOJ, QFJ (PLCC), SHP and BGA are surface mount type packages, which are very susceptible to heat in reflow mounting and humidity absorbed in storage. Therefore, before you perform reflow mounting, contact Oki's responsible sales person for the product name, package name, pin number, package code and desired mounting conditions (reflow method, temperature and times).

(Unit : mm)

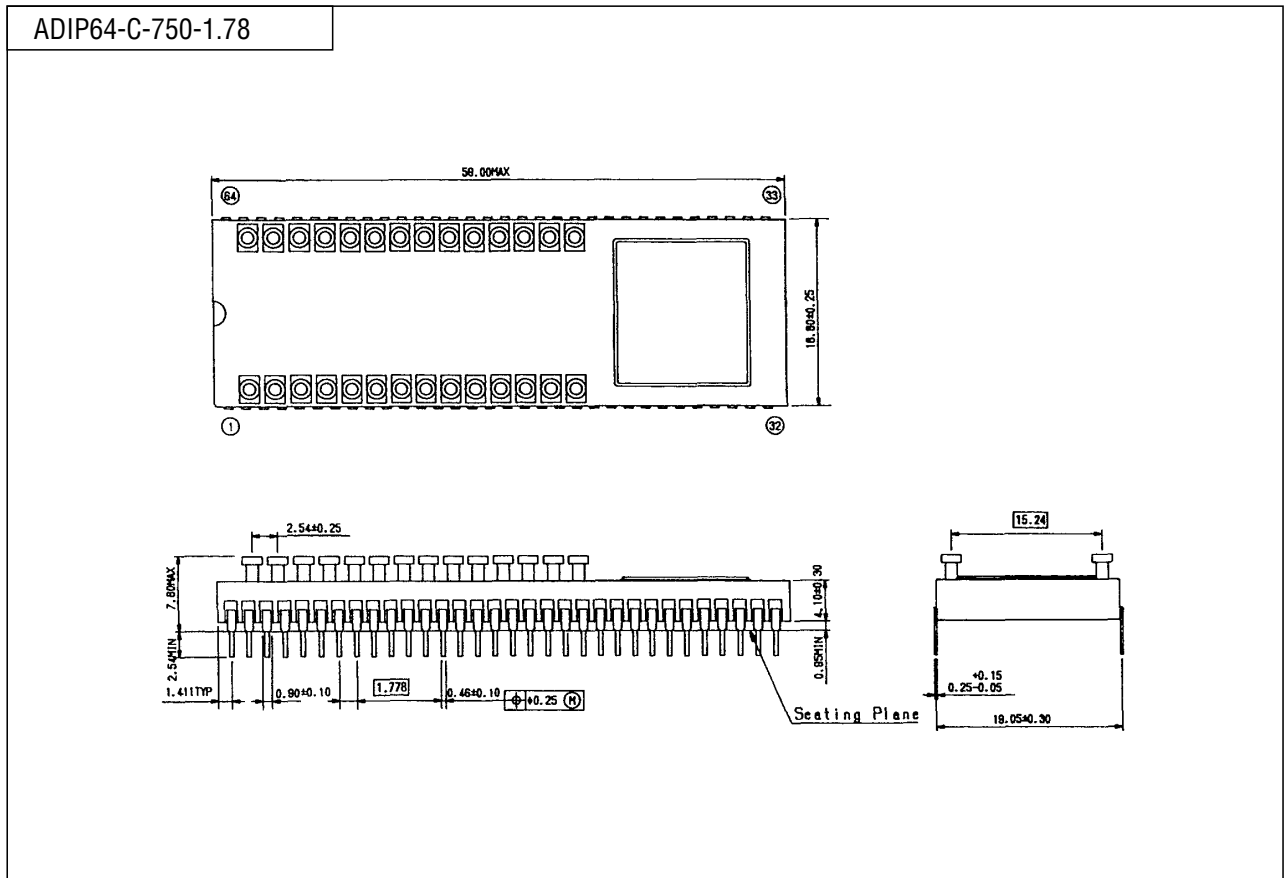

Notes for Mounting the Surface Mount Type Package

The SOP, QFP, TSOP, SOJ, QFJ (PLCC), SHP and BGA are surface mount type packages, which are very susceptible to heat in reflow mounting and humidity absorbed in storage. Therefore, before you perform reflow mounting, contact Okí's responsible sales person for the product name, package name, pin number, package code and desired mounting conditions (reflow method, temperature and times).